

Operating manual

Rotary screw blower

HBS pr SIGMA CONTROL 2

No.: 902347 03 USE

Manufacturer:

KAESER KOMPRESSOREN SE

96410 Coburg • PO Box 2143 • GERMANY • Tel. +49-(0)9561-6400 • Fax +49-(0)9561-640130

www.kaeser.com

Original instructions
/KKW/BHBCP 2.13 en Z1 SBA-SCHRAUBENGEBLAESE

20220708 112916

1	Regarding this Document	
1.1	Using this document	1
1.2	Further documents	1
1.3	Copyright	1
1.4	Symbols and labels	1
1.4.1	Warnings	1
1.4.2	Potential damage warnings	2
1.4.3	Other alert notes and their symbols	2
2	Technical Data	
2.1	Nameplate	4
2.2	Option codes	4
2.3	Weight	5
2.4	Recommended oil	5
2.5	Lubricating oil charge	6
2.6	Permitted working pressure	6
2.7	Temperature	6
2.8	Ambient and intake conditions	7
2.9	Sound pressure level/sound power level	7
2.10	Power supply	7
2.11	Power supply specifications	8
2.11.1	START CONTROL (STC)	8
2.11.2	SIGMA FREQUENCY CONTROL (SFC)	9
2.12	Options	10
2.12.1	Oil level monitoring	10
2.12.2	Oil temperature monitoring	10
2.12.3	Check valve	10
2.12.4	Piped inlet	10
2.12.5	Fan (sound enclosure)	11
3	Safety and Responsibility	
3.1	Basic instructions	12
3.2	Specified use	12
3.3	Improper use	12
3.4	User's responsibilities	13
3.4.1	Observe statutory and universally accepted regulations	13
3.4.2	Determining personnel	13
3.5	Dangers	13
3.5.1	Safely dealing with sources of danger	13
3.5.2	Safe machine operation	16
3.5.3	Organizational measures	18
3.6	Danger areas	18
3.7	Safety devices	18
3.8	Working life of safety functions	19
3.9	Safety signs	19
3.10	In emergency	22
3.10.1	Correct fire fighting	22
3.10.2	Remove lubricating oil from the skin.	23
3.11	Environmental protection	23
3.12	Warranty	23
4	Design and Function	
4.1	Enclosure	24
4.2	SIGMA CONTROL 2 operating panel	25
4.2.1	Keys	25
4.2.2	LEDs	26

4.2.3	RFID sensor field	26
4.3	Machine	27
4.4	Blower block	28
4.5	Safety relief valve	28
4.6	Safety devices	29
4.7	Compensator	29
4.8	Automatic starting	29
4.9	Automatic lubrication system	29
4.10	Floating relay contacts	30
4.11	Options	30
4.11.1	Oil level monitor	30
4.11.2	Oil temperature monitoring	30
4.11.3	Electrical connection: bottom	31
4.11.4	Check valve	31
4.11.5	Piped inlet	32
5	Installation and Operating Conditions	
5.1	Ensuring safety	33
5.2	Installation conditions	33
5.2.1	Determining installation location and clearances	33
5.2.2	Ensuring adequate ventilation	34
6	Installation	
6.1	Ensuring safety	35
6.2	Reporting transport damage	36
6.3	Align the blower block and secure the machine	36
6.4	Connecting the power supply	37
6.4.1	Under frequency control	37
6.5	Making the compressed air connection	38
6.6	Connecting the inlet pipeline	39
6.7	Sound enclosure: Installing the exhaust air ducting	39
7	Initial Start-up	
7.1	Ensuring safety	41
7.2	Instructions to be observed before commissioning	42
7.3	Checking installation and operating conditions	42
7.4	Configuring the controller	43
7.5	Setting the display language	43
7.6	Checking the direction of rotation for the drive motor	44
7.7	Starting the machine for the first time	44
8	Operation	
8.1	Switching on and off	46
8.1.1	Switching on	46
8.1.2	Switching off	47
8.2	Switching off in an emergency and switching on again	47
8.3	Switching on and off from a remote control center	47
8.4	Switching on and off with the clock (timer)	48
8.5	Checking the ventilator fan function (sound enclosure)	49
8.6	Interpreting operation messages	50
8.7	Acknowledging alarm and warning messages	50
9	Fault Recognition and Rectification	
9.1	Basic instructions	52
9.2	Other faults	52
9.3	Sound enclosure faults	53

10	Maintenance	
10.1	Ensuring safety	54
10.2	Maintenance schedule	55
10.2.1	Logging maintenance work	55
10.2.2	Resetting maintenance interval counters	55
10.2.3	Regular maintenance tasks	55
10.2.4	Regular maintenance tasks	56
10.3	Control cabinet: Clean or replace the filter mats	57
10.4	Sound enclosure	58
10.5	Checking the oil level	58
10.6	Replenishing lubricating oil	59
10.7	Changing the lubricating oil	60
10.7.1	Returning the oil chamber ventilation lubricating oil	60
10.7.2	Changing the blower block lubricating oil	61
10.8	Air filter maintenance	62
10.8.1	Changing the air filter	62
10.9	Machine cleaning	63
10.10	Motor maintenance	64
10.10.1	Drive motor bearings	64
10.10.2	Fan motor	64
10.10.3	Servicing the automatic lubrication system	64
10.11	Checking the coupling	66
10.11.1	Visual inspection for uneven or noisy running	67
10.11.2	Visually check for damages	67
10.12	Testing the safety relief valve	68
10.13	Testing the EMERGENCY STOP push button	68
10.14	Documenting maintenance and service work	70
11	Spares, Operating Materials, Service	
11.1	Note the nameplate	71
11.2	Ordering spare parts and operating fluids/materials	71
11.3	Spare parts for service and repair	71
11.4	KAESER AIR SERVICE	74
11.5	Completing the contamination declaration	74
12	Decommissioning, Storage and Transport	
12.1	Decommissioning	75
12.2	Packing	75
12.3	Transport	76
12.3.1	Safety	76
12.3.2	Transport machine with a pallet truck or forklift truck	76
12.4	Storage	76
12.5	Disposal	77
12.5.1	Battery disposal in accordance with local environmental regulations	77
13	Annex	
13.1	Pipeline and instrument flow diagram (P+I diagram)	78
13.2	Dimensional drawing	82
13.3	Noise emission	84
13.4	Electrical diagram	86
13.5	Project planning data	110

Fig. 1	Three-phase star (wye); 4 wire; grounded neutral	8
Fig. 2	Three-phase star (wye); 3 wire; grounded neutral	8
Fig. 3	Location of the safety signs on the machine	20
Fig. 4	Safety sign location, electronically activated components	20
Fig. 5	Enclosure overview	24
Fig. 6	Indicating and operating elements	25
Fig. 7	Indicating and operating elements	26
Fig. 8	RFID sensor field	27
Fig. 9	Machine	27
Fig. 10	Blower block	28
Fig. 11	Safety relief valve (blow-off valve)	28
Fig. 12	Compensator	29
Fig. 13	Automatic lubrication system	30
Fig. 14	Electrical connection: bottom	31
Fig. 15	Non-return flap	32
Fig. 16	Recommended positioning of the machine, minimum dimensions [in.]	34
Fig. 17	Blower block (top view)	36
Fig. 18	Assembling the two collar halves	39
Fig. 19	Installing the exhaust air ducting	40
Fig. 20	Switching the machine on and off	46
Fig. 21	Switching off in an emergency	47
Fig. 22	Switching on and off from a remote control center	48
Fig. 23	Switching on and off with the clock (timer)	49
Fig. 24	Acknowledging messages	50
Fig. 25	Control cabinet ventilation	57
Fig. 26	Sound enclosure	58
Fig. 27	Checking the oil level	59
Fig. 28	Replenishing lubricating oil	60
Fig. 29	Changing the lubricating oil	61
Fig. 30	Changing the air filter	63
Fig. 31	Actuator display	64
Fig. 32	Grease cartridge fill date	65
Fig. 33	Changing the grease cartridge	66
Fig. 34	Checking the coupling	67
Fig. 35	Testing the safety relief valve	68
Fig. 36	Testing the EMERGENCY STOP push button	68
Fig. 37	Transport	76
Fig. 38	Battery labelling	77

Tab. 1	Danger levels and their definition (personal injury)	1
Tab. 2	Danger levels and their definition (damage to property)	2
Tab. 3	Nameplate	4
Tab. 4	Option codes	4
Tab. 5	Weight	5
Tab. 6	Recommended oil	5
Tab. 7	Lubricating oil charge	6
Tab. 8	Permitted working pressure	6
Tab. 9	Temperature	6
Tab. 10	Ambient and intake conditions	7
Tab. 11	Connection data 460V / 3 / 60Hz	8
Tab. 12	Rated power supply 575V±10% / 3 / 60Hz	9
Tab. 13	Connection data 460V / 3 / 60Hz	9
Tab. 14	Oil level monitoring (Option C5)	10
Tab. 15	Oil temperature monitoring (Option C39)	10
Tab. 16	Check valve (Option G1)	10
Tab. 17	Fan flow rate	11
Tab. 18	Danger areas	18
Tab. 19	Category and Performance Level	19
Tab. 20	Safety signs	20
Tab. 21	Controls	25
Tab. 22	Display elements	26
Tab. 23	RFID sensor field	27
Tab. 24	Compensator torques at discharge side	38
Tab. 25	Inlet compressor torques	39
Tab. 26	Recommissioning after storage/standstill	42
Tab. 27	Installation conditions check list	42
Tab. 28	Machine identification	48
Tab. 29	Remote control identification	48
Tab. 30	Machine identification	49
Tab. 31	Other faults and remedies	52
Tab. 32	Faults and remedies (option H12)	53
Tab. 33	Regular maintenance tasks	55
Tab. 34	Regular maintenance tasks	56
Tab. 35	Automatic lubrication system indicator	64
Tab. 36	Logged maintenance tasks	70
Tab. 37	Ordering spare parts and operating fluids/materials	71
Tab. 38	Noise emission	84

1 Regarding this Document

1.1 Using this document

This operating or installation manual is part of the machine. It describes the machine as it was at the time of first delivery after manufacture.

- Keep the operating manual in a safe place throughout the life of the machine.
- Pass the operating manual on to the next owner/user.
- Ensure that all amendments received are entered or inserted in the operating manual.
- Enter details from the machine nameplate and individual items of equipment in the tables in chapter 2.

1.2 Further documents

Included with this Operating Manual are additional documents intended to assist in the safe operation of the machine:

- Manufacturer's Declaration or Declaration of Conformity according to applicable directives.
- User Manual for SIGMA CONTROL 2.

Missing documents can be requested from KAESER.

- Ensure that all documents are complete and observe the instructions contained within them.
- Ensure that you provide the data from the nameplate when ordering documents.

1.3 Copyright

This operator manual is copyright protected. Queries regarding use or duplication of the documentation should be referred to KAESER. Correct use of information will be fully supported.

1.4 Symbols and labels

- Please note the symbols and labels used in this document.

1.4.1 Warnings

Warnings indicate danger potentially resulting in personal injury, if the measures specified are not taken.

Warnings indicate three levels of danger identified by the corresponding signal word:

Signal term	Meaning	Consequences of non-compliance
DANGER	Warns of imminent danger	Will very likely result in death or severe injury
WARNING	Warns of potentially imminent danger	May result in death or severe injury
CAUTION	Warns of a potentially dangerous situation	May result in moderate physical injury

Tab. 1 Danger levels and their definition (personal injury)

Warning notes may precede a chapter. They apply to the entire chapter including all sub-sections.

1 Regarding this Document

1.4 Symbols and labels

Example:

⚠ DANGER

The type and source of the imminent danger is shown here!

The possible consequences of ignoring a warning are shown here.

The word "DANGER" indicates that death or severe injury can very likely result from ignoring the warning.

➤ *The measures required to protect yourself from danger are shown here.*

Warning notes referring to a sub-section or the subsequent step are integrated into the procedure and numbered as a step.

Example:

1. **⚠ WARNING** *The type and source of the imminent danger is shown here!*
The possible consequences of ignoring a warning are shown here.
The word "WARNING" indicates that death or severe injury may result from ignoring the warning.
➤ *The measures required to protect yourself from danger are shown here.*
2. Always read and comply with warning instructions.

1.4.2 Potential damage warnings

Contrary to the warnings shown above, damage warnings do not indicate potential personal injury.

Damage warnings have only one danger level, identified by this signal word:

Signal term	Meaning	Consequences of non-compliance
NOTE	Warns of a potentially dangerous situation	Damage to property is possible

Tab. 2 Danger levels and their definition (damage to property)

Example:

NOTICE

The type and source of the imminent danger is shown here!

Potential effects when ignoring the warning are indicated here.



➤ *The protective measures against the damages are shown here.*

➤ Carefully read and fully comply with warnings against damages.

1.4.3 Other alert notes and their symbols



This symbol indicates particular important information.

- Material Here you will find details on special tools, operating materials or spare parts.
- Precondition Here you will find conditional requirements necessary to carry out the task.
The conditional requirements relevant to safety shown here will help you to avoid dangerous situations.
- Option H12 ➤ This symbol is placed by lists of actions comprising one stage of a task.
Operating instructions with several steps are numbered in the sequence of the operating steps.
Information relating to one option only are marked with an option code (e.g., H12 indicates that this section applies only to machines with sound enclosure). Option codes used in this operating manual are explained in chapter 2.2.
-  Information referring to potential problems are identified by a question mark.
The cause is specified in the help text ...
➤ ... as is a solution.
-  This symbol refers to important information or measures concerning environmental protection.
- Further information Further subjects are introduced here.

2 Technical Data

2.1 Nameplate

The machine's nameplate contains the model type and important technical information.

The nameplate is attached to the machine stand and at the left side wall of the sound enclosure (Option H12).

The specified value for the full load current has been calculated including the associated lambda factor. This value can be found in chapter 2.11.2 (Option C38).

The information given on the nameplate relates to the standard inlet conditions of 14.7 psi and +68°F.

➤ Enter the data from the nameplate here as a reference:

Characteristic	Value
Rotary screw blower	
Part no.	
Serial no.	
Ambient temperature	
Rated power	
Max. gauge working pressure PS	
Rated motor speed	
Full load current	
Full load current, drive motor	
Electrical connection	
Wiring diagram	
Year of manufacture	

Tab. 3 Nameplate

2.2 Option codes

The table contains a list of possible options.

➤ Enter options here as a reference:

Option	Option code	Available?
Operating mode: Gauge pressure	B13	✓
Oil level monitoring	C5	✓
Speed monitor	C10	—
Unloaded start valve	C11	—
Unloaded start valve with regulating valve	C18	—
Under frequency control	C32	✓
START CONTROL (STC)	C33	—

available: ✓

Not available: —

Option	Option code	Available?
SIGMA FREQUENCY CONTROL (SFC)	C38	✓
Oil temperature monitoring	C39	✓
Communication module: PROFIBUS DP	C41	
Communication module: Modbus RTU	C42	
Communication module: DEVICENET	C43	
Communication module: Modbus TCP	C44	
Communication module: PROFINET IO	C45	
Electrical connection: bottom	C52	
Check valve	G1	
Intake from pipe	H11	
Sound enclosure	H12	✓
available: ✓		
Not available: —		

Tab. 4 Option codes

2.3 Weight

The values shown are maximum values. The actual weight of individual machines depends on equipment fitted.

Rated power [hp]	Weight [lb]		
	HBS 1600 L pr	HBS 1600 M pr	—
175	12754	—	—
200	12919	12952	—
250	12963	12996	—
300	—	13095	—
—	—	—	—
—	—	—	—
—	—	—	—
—	—	—	—
—	—	—	—

Tab. 5 Weight

2.4 Recommended oil

The lubricant type to be used depends on the operating conditions.

	SIGMA FLUID	
	G-680	FGB-680
Description	Synthetic oil	Synthetic oil

	SIGMA FLUID	
	G-680	FGB-680
Application	Suitable for all applications, except food processing.	Specifically for machines in applications where the compressed air may come into contact with food products.

Tab. 6 Recommended oil

Further information Adhesive labels giving the oil type for topping off can be found at the corresponding inlet ports at the blower block.

Please see chapter 11.2 for information on ordering oil.

2.5 Lubricating oil charge

The block oil chambers are filled with oil at the factory.

Guide value

	Drive-end	Gear-end
Lubricating oil charge [qt]	4.2 ±15 %	6.3 ±15 %

Tab. 7 Lubricating oil charge

2.6 Permitted working pressure

Undershooting of the minimum working pressure, or overshooting of the maximum working pressure is not permitted. The working pressures during the start and shut-down phases are exceptions.

	HBS 1600 L pr	HBS 1600 M pr
Minimum working pressure [psi (g)]	4.4	4.4
Maximum working pressure [psi (g)]	10.2	16.0

Tab. 8 Permitted working pressure

2.7 Temperature

	HBS 1600 L pr	HBS 1600 M pr
Maximum block discharge temperature [°F]	239	293
Maximum temperature differential [K] *	70	100

*Discharge temperature minus inlet temperature

Tab. 9 Temperature

2.8 Ambient and intake conditions

The following conditions must be maintained:

- No salty atmosphere in the immediate vicinity of the machine.
- The air must be free of chemicals or explosive substances.

	HBS 1600 L pr	HBS 1600 M pr	—
Permissible ambient temperature [°F]	32 – 113	32 – 113	—
Permissible intake temperature [°F]	5 – 113	5 – 113	—
Relative humidity [%]	0 – 80	0 – 80	—
Maximum altitude AMSL [ft.]	3281	3281	—

Tab. 10 Ambient and intake conditions



Differing ambient and intake conditions require the recalculation of the performance data, and are permissible only upon agreement by the manufacturer.

2.9 Sound pressure level/sound power level

Operating state LOAD under the following conditions:

- Nominal speed
- Nominal flow rate
- Nominal pressure

Measuring condition according to DIN EN ISO 2151 and basic standard ISO 9614–2:

- Measurement distance: 3 ft
- Tolerance: ±3 dB(A)
- Sound insulated pipeline

Further information The sound pressure level and sound power level values for your machine are provided in the tables shown in chapter 13.3.

These values refer to the design condition.

2.10 Power supply

Basic requirements

The machine is designed for an electrical supply according to National Electric Code (NEC), edition 2020, particularly article 670 and NFPA 79, edition 2021, particularly section 4.4. In the absence of any user-specified alternatives, the limits given in these standards must be adhered to. Consult manufacturer for any other specific power supply.

The incoming line within the control panel should be as short as possible.

If external sensors or communication lines are to be connected to the machine, use shielded cables and insert the same through EMC fittings into the control panel.

Three-phase

Do **NOT** operate package on any unsymmetrical power supply. Also do **NOT** operate package on power supplies like, for example, a three-phase (open) delta or three-phase star with non-grounded neutral.

The machine requires a symmetrical three-phase power supply transformer with a WYE configuration output as shown in Figure 1 and Figure 2. In a symmetrical three phase supply the phase angles and voltages are all the same.

Other power supplies are not suitable.

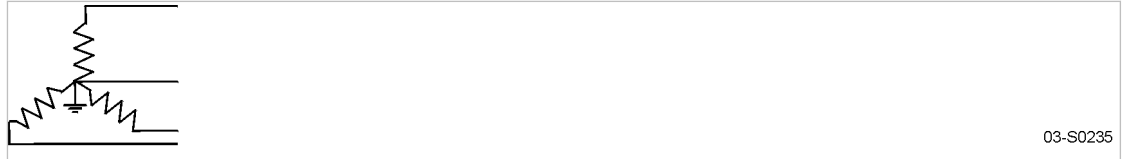

Fig. 1 Three-phase star (wye); 4 wire; grounded neutral

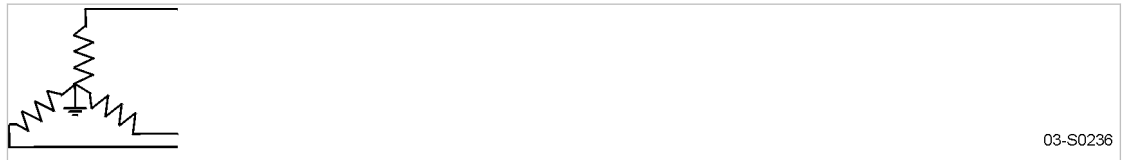

Fig. 2 Three-phase star (wye); 3 wire; grounded neutral

Further information Please contact authorized KAESER Service representative for options.
The electrical diagram 13.4 contains further specifications for electrical connection.

2.11 Power supply specifications

The following multi-strand copper core wires are given according to 2020 NEC 310.14, 310.15, 310.16 and table 310.16 adjusted for 40°C ambient temperature.

If other local conditions prevail, like for example high temperature, the cross section should be checked and adjusted according to 2020 NEC 110.14(C). 220.3. 310.14. 310.15. 310.16, 310.15(B)(1), table 310.15(C)(1). 430.6. 430.22. 430.24. 670.4(A) and other local codes.

Dual element time delay fuses are selected according to 2020 NEC 240.6. 430.52 and tables 430.52. 430.248 and 430.250.

We strongly suggest using a separate copper conductor for the equipment GROUNDING. 2020 NEC table 250.122 will point out the "minimum size", however, we recommend a ground conductor the same size as the power leads, if local codes allow.

**2.11.1 Option C33
START CONTROL (STC)**

Rated power supply: 460V±10% / 3 / 60Hz

Rated power [hp]	175	200	250	300	—	—	—	—	—
Backup fuse [A]	—	—	—	—	—	—	—	—	—
Supply line [AWG]	—	—	—	—	—	—	—	—	—

Rated power [hp]	175	200	250	300	—	—	—	—	—
Current consumption [A]	—	—	—	—	—	—	—	—	—

Tab. 11 Connection data 460V / 3 / 60Hz

Rated power supply: 575V±10% / 3 / 60Hz

Rated power [hp]	175	200	250	300	—	—	—	—	—
Backup fuse [A]	—	—	—	—	—	—	—	—	—
Supply line [AWG]	—	—	—	—	—	—	—	—	—
Current consumption [A]	—	—	—	—	—	—	—	—	—

Tab. 12 Rated power supply 575V±10% / 3 / 60Hz

**2.11.2 Option C38
 SIGMA FREQUENCY CONTROL (SFC)**
Protective conductor requirements

Due to the leakage currents of ≥ 10 mA caused by the anti-interference capacitors in the frequency converter, a minimum diameter of 8 AWG is required for the protective conductor.

Use one of the following options if the protective conductor for the supply cable is smaller than 8 AWG:

- Multicore cable including protective conductor with a minimum cross-section of 8 AWG,
- a minimum cross-section of 8 AWG for the protective conductor alone,
- a second protective conductor with the same cross-section as the supply line,
- automatic deactivation of the power supply as soon as the protective conductor is interrupted.

Note on the lambda factor:

In addition to their fundamental oscillation, non-sinusoidal variables also contain harmonics for which no fixed phase shift angle ϕ (phi) can be specified. Instead, the power factor λ (lambda) must be used. In electrical engineering, the power factor λ denotes the ratio of the active power value P to the apparent power value S.

In the event of deviating network characteristics and therefore lambda value at the user-end, the full load current and supply cable cross-section may need to be reassessed.

Rated power supply: 460V / 3 / 60Hz

Rated power [hp]	175	200	250	300	—	—	—	—	—
Backup fuse [A]	250	300	400	450	—	—	—	—	—
Supply line [AWG]	2x 4x3/0	2x 4x4/0	2x 4x300 MCM	2x 4x400 MCM	—	—	—	—	—
Current consumption [A]	219.7	260.3	324.1	365.0	—	—	—	—	—
Power factor [λ] (lambda)	0.935	0.930	0.929	0.927	—	—	—	—	—

Tab. 13 Connection data 460V / 3 / 60Hz

2.12 Options

Technical data for the options available for your machine are given in the following.

2.12.1 Option C5 Oil level monitoring

Feature	Data
Max. voltage [V]	48
Switching current [A]	0.5
Switching capacity [hp]	0.03
Type of contact	Normally closed
Degree of protection	IP67

Tab. 14 Oil level monitoring (Option C5)

Further information The electrical diagram in chapter 13.4 contains details of the power supply.

2.12.2 Option C39 Oil temperature monitoring

Feature	Data
Measuring element	PT100
Measuring range [°F]	-58 – +392
Connection	M12x1 circular connection
Switching type	2-conductor switching
Process connection [“]	G 1/4 screw-in thread

Tab. 15 Oil temperature monitoring (Option C39)

Further information The electrical diagram in chapter 13.4 contains details of the power supply.

2.12.3 Option G1 Check valve

Flange connection	Max. pressure and back pressure [psi]
DN 300	18.9

Tab. 16 Check valve (Option G1)

2.12.4 Option H11 Piped inlet

The dimensional drawings in chapter 13.2 include connection dimensions.

2.12.5 Option H12
Fan (sound enclosure)

Feature	Value
Maximum flow rate [cfm]	4355

Tab. 17 Fan flow rate

3 Safety and Responsibility

3.1 Basic instructions

The machine is manufactured to the latest engineering standards and acknowledged safety regulations. Nevertheless, dangers can arise through its operation:

- Danger to life and limb of the operator or third parties,
- Damages to the machine and other material assets.



Disregard of warning or safety instructions can cause serious injuries!

- Read the operating and installation manual carefully and take note of the contents for safe machine operation.
- Use this machine only if it is in a technically perfect condition and only for the purpose for which it is intended; observe all safety measures and the instructions in the service manual!
- Immediately rectify (have rectified) any faults that could be detrimental to safety!

3.2 Specified use

The machine is designed exclusively for the generation of pressure in a commercial or industrial environment where air (in the following "compressed air") as delivery medium is approved for use. Any other use is considered incorrect. The manufacturer is not liable for any damages that may result from incorrect use. The user alone is liable for any risks incurred.

- Comply with the instructions in this operating manual.
- Operate the machine only within its performance limits and under the permitted ambient conditions.
- Do not use compressed air for breathing purposes unless it is specifically treated.
- Do not use compressed air for any application that will bring it into direct contact with food products unless it is specifically treated.
- Operate the blower block only with inlet and outlet ports connected.

3.3 Improper use

Improper usage can cause damage to property and/or (severe) injuries.

- Only use the machine as intended.
- Never direct compressed air at persons or animals.
- Use hot cooling air for heating purposes only if there is no risk to the health of humans or animals. If necessary, hot cooling air should be treated by suitable means.
- Do not allow the machine to take in toxic, acidic, flammable, or explosive gases or vapors.
- Do not operate the machine in areas in which specific requirements with regard to explosion protection are in force.
- Intake of solid particles >0.004 inch is not permitted.

3.4 User's responsibilities

3.4.1 Observe statutory and universally accepted regulations

- Observe relevant statutory and accepted regulations during installation, operation and maintenance of the machine.

3.4.2 Determining personnel

Suitable personnel are experts who, by virtue of their training, knowledge, and experience, as well as their knowledge of relevant regulations, can assess the work to be done and recognize the possible dangers involved.

Authorized operators possess the following qualifications:

- are of legal age,
- are familiar with and adhere to the safety instructions and sections of the service manual relevant to operation,
- have received adequate training and authorization to operate electrical and compressed air devices.

Authorized installation and maintenance personnel have the following qualifications:

- are of legal age,
- have read, are familiar with and adhere to the safety instructions and sections of the service manual applicable to installation and maintenance,
- are fully familiar with the safety concepts and regulations of electrical and compressed air engineering,
- are able to recognize the possible dangers of electrical and compressed air devices and take appropriate measures to safeguard persons and property,
- have received adequate training in and authorization for the safe installation and maintenance of this machine.

- Ensure that personnel entrusted with operation, installation, and maintenance are qualified and authorized to carry out their tasks.

3.5 Dangers

Basic instructions

Information concerning the various forms of danger that can arise during machine operation are found here.

Basic safety instructions are found in this service manual at the beginning of each chapter in the section entitled 'Safety'.

Warning instructions are found before a potentially dangerous task.

3.5.1 Safely dealing with sources of danger

The following describes the various forms of danger that can occur during machine operation.

Electricity

Touching voltage carrying components can result in electric shocks, burns or even death.

- All power supplies must be fitted with lockable power supply disconnecting devices by the user.
- Allow only qualified and authorized certified electricians or trained personnel under the supervision of a qualified and authorized certified electrician to carry out work on electrical equipment according to electrical engineering regulations.
- Before commissioning or recommissioning the machine, the user must ensure adequate protection against electric shock from direct or indirect contact.
- Before starting any work on electrical equipment:
Switch off and lock out/tag out the power supply disconnecting device and verify the absence of any voltage.
- Switch off any external power sources.
These may be connections to the electric machine heating for example.
- Use fuses corresponding to machine power.
- Regularly check that all electrical connections are tight and in proper condition.

Forces of compression

Compressed air is contained energy. Uncontrolled release of this energy can cause serious injury or death. The following information concerns work on components that may be under pressure.

- Close shut-off valves or otherwise isolate the machine from the compressed air network to ensure that no compressed air can flow back into the machine.
- Fully vent all pressurized components and enclosures.
- Allow no person or thing to remain near the safety relief valve during machine operation. In the event of working pressure being exceeded, hot gas is blown off at high velocity and the safety relief valve control rod is blown upward with great force.
- Do not carry out welding, heat treatment or mechanical modifications on pressurized components, as this adversely affects the components' resistance to pressure.
The safety of the machine is then no longer ensured.

Compressed air quality

The composition of the compressed air must be suitable for the actual application in order to preclude health and life-threatening dangers.

- Use appropriate systems for air treatment before using the compressed air from this machine as breathing air and/or for the processing of food products.
- Use food grade lubricating oil whenever compressed air is to come into contact with food products.

Spring forces

Springs under tension or compression store energy. Uncontrolled release of this energy can cause serious injury or death.

The safety relief valve and the unloaded-start valve are under subject to powerful spring loading.

- Do not open or dismantle any valves.

Rotating components

Touching the fan wheel while the machine is switched on can result in serious injury.

- Do not remove separating protective devices when the machine is running.
- Switch off and lock out/tag out the power supply disconnecting device and verify the absence of any voltage.
- Wear close-fitting clothes and a hair net if necessary.
- Ensure that all covers and safety guards are in place and secured before restarting.

Temperature

High temperatures are generated during compression. Touching hot components may cause injuries.

- Avoid contact with hot components.
These include, for example, blower block, silencers, oil and compressed air lines, motors and machine heaters.
- Wear protective clothing.
- If work is carried out on or near the machine, take adequate measures to prevent sparks or heat from igniting oil vapors or parts of the machine.

Noise

The sound enclosure absorbs and reduces the machine noise to a tolerable level. This function is only effective if the sound enclosure is closed.

- Wear ear protection if necessary.
Safety relief valve blow off result in high noise emission.

Operating fluids/materials

The operating fluids and materials used can cause adverse health effects. Suitable safety measures must be taken in order to prevent injuries.

- Strictly forbid fire, open flames and smoking.
- Follow safety regulations when handling oils, lubricants and chemical substances.
- Avoid contact with skin and eyes.
- Do not inhale oil mist and vapors.
- Do not eat or drink while handling lubricants.
- Keep appropriate fire extinguishing agents ready for use.
- Use only KAESER approved operating fluids and materials.

Unsuitable spare parts

Unsuitable spare parts compromise the safety of the machine.

- Use only spare parts approved by the manufacturer for use in this machine.
- Use only genuine KAESER spare parts on pressure bearing parts.

Conversion or modification of the machine

Modifications, additions or conversions to or of the machine can result in unpredictable hazards.

- Do not convert or modify the machine!
- Prior to any technical modification and expansions of the machine, obtain the written approval of the manufacturer.

Extending or modifying the compressed air station

If dimensioned appropriately, safety relief valves reliably prevent any impermissible pressure rise. New dangers may arise if you modify or extend the compressed air station.

- When extending or modifying the compressed air station:
Check the blow off capacity of the safety relief valves prior to installing the new machine.
- If the blow-off capacity is insufficient:
Install safety relief valves with larger blow off capacity.

3.5.2 Safe machine operation

The following is information supporting you in the safe handling of the machine during individual product life phases.

Personal protective equipment

When working on the machine you may be exposed to dangers that can result in accidents with severe adverse health effects.

- Wear protective clothing as necessary.

Suitable protective clothing (examples):

- Safety work wear
- Protective gloves
- Safety boots
- Eye protection
- Ear protection

Transporting

The weight and size of the machine require safety measures during its transport to prevent accidents.

- Use suitable lifting gear that conforms to local safety regulations.
- Allow transportation only by personnel trained in the safe movement of loads.
- Attach lifting gear only to suitable lifting points.
- Be aware of the center of gravity to avoid potential tipping.
- Make sure the danger zone is clear of personnel.
- Do not step onto machine components to climb up the machine.

Assembly

- Make sure no power is applied when electrical connections are made.
- Use only electrical cables that are suitable and approved for the surroundings and electrical loads applied.
- Never dismantle compressed air pipes until they are fully vented.
- Only use pressure lines that are suitable and approved for the maximum working pressure and the intended medium.
- Do not allow connection pipes to be placed under mechanical stress.
- Do not induce any forces into the machine via the connections, so that the compressive forces must be balanced by bracing.
- Do not step onto machine components to climb up the machine.

Positioning

A suitable installation location for the machine prevents the potential for accidents and faults.

- Install the machine in a suitable compressor room.
- Ensure sufficient and suitable lighting such that the display can be read and work carried out comfortably and safely.
- Ensure accessibility so that all work on the machine can be carried out without danger or hindrance.
- If installed outdoors, the machine must be protected from frost, direct sunlight, dust, rain and splashing water.
- Do not operate in areas in which specific requirements with regard to explosion protection are in force.
- Ensure adequate ventilation.
- Place the machine in such a manner that the working conditions in its environment are not impaired.
- Comply with limit values for ambient temperature and humidity.
- The intake air must not contain any damaging contaminants, Damaging contaminants are for instance: explosive or chemically instable gases and vapors, acid or base forming substances such as ammonia, chlorine or hydrogen sulfide.
- Do not position the machine in the warm exhaust air flow from other machines.
- Keep suitable fire extinguishing agents ready for use.

Commissioning, operation and maintenance

During commissioning, operation and maintenance you may be exposed to dangers resulting from, e.g., electricity, pressure and temperature. Careless actions can cause accidents with severe adverse effects for your health.

- Allow maintenance work to be carried out only by authorized personnel.
- Wear close-fitting, flame-resistant clothing. Wear protective clothing as necessary.
- Switch off and lock out the power supply disconnecting device, and verify the absence of voltage.
- Check that there is no voltage on floating relay contacts.
- Close shut-off valves or otherwise isolate the machine from the distribution network to ensure that no compressed air can flow back into the machine.
- Depressurize all pressurized components and enclosures.
- Allow the machine to cool down.
- Do not open the sound enclosure while the machine is switched on.
- Do not open or dismantle any valves.
- Use only spare parts approved by KAESER for use in this machine.
- Carry out regular inspections:
 - for visible damages,
 - of safety installations,
 - of the EMERGENCY STOP push button,
 - of any components requiring monitoring.
- Pay particular attention to cleanliness during all maintenance and repair work. Cover components and openings with clean cloths, paper or tape to keep them clean.

- Do not leave any loose components, tools or cleaning rags on or in the machine.
- Components removed from the machine can still be dangerous.
Do not attempt to open or destroy any components taken from the machine.

Decommissioning, storage and disposal

Improper handling of old operating fluids and components represent a danger for the environment.

- Drain off fluids and dispose of them according to environmental regulations.
These include, for example, lubricating oil.
- Dispose of the machine in accordance with local environmental regulations.

3.5.3 Organizational measures

- Designate personnel and their responsibilities.
- Give clear instructions on reporting faults and damage to the machine.
- Give instructions on fire reporting and fire-fighting measures.

3.6 Danger areas

The table gives information on areas dangerous to personnel.

Only authorized personnel may enter these areas.

Function	Danger area	Authorized personnel
Transporting	Within a 10 ft radius of the machine.	Installation personnel for transporting preparation. No personnel during transporting.
	Beneath the lifted machine.	No personnel!
Installation	Within the machine. Within 3 ft radius of the machine and its power supply cables.	Installation personnel
Operation	Within a 3 ft radius of the machine.	Operating personnel
Maintenance	Within the machine.	Maintenance personnel
	Within a 3 ft radius of the machine.	

Tab. 18 Danger areas

3.7 Safety devices

Various safety devices ensure safe working with the machine.

- Do not change, bypass or disable safety devices.
- Check safety devices for correct function regularly.
- Do not remove or obliterate labels and notices.
- Ensure that labels and notices are clearly legible.

Further information More information on safety devices is contained in chapter 4, section 4.6.

3.8 Working life of safety functions

Pursuant to ISO 13849-1:2015, Category and Performance Level (PL) of the machine's safety functions have been analyzed and assessed:

Safety function	Category	Performance Level
EMERGENCY STOP push button	1	c

Tab. 19 Category and Performance Level

The safety-relevant components of the safety devices are designed for a working life of 20 years. The working life starts with the commissioning, and is not extended by times during which the machine was not in use.

The following components are affected:

- EMERGENCY STOP push button
- Option C38, SIGMA FREQUENCY CONTROL (SFC):
Frequency converter

1. The components of the safety devices must be replaced by an authorized KAESER service representative after a working life of 20 years.
2. Have an authorized KAESER service representative check the reliability of the safety functions.

3.9 Safety signs

The illustration shows the location of the safety signs on the machine. Table 20 lists the various safety signs used and their meanings.

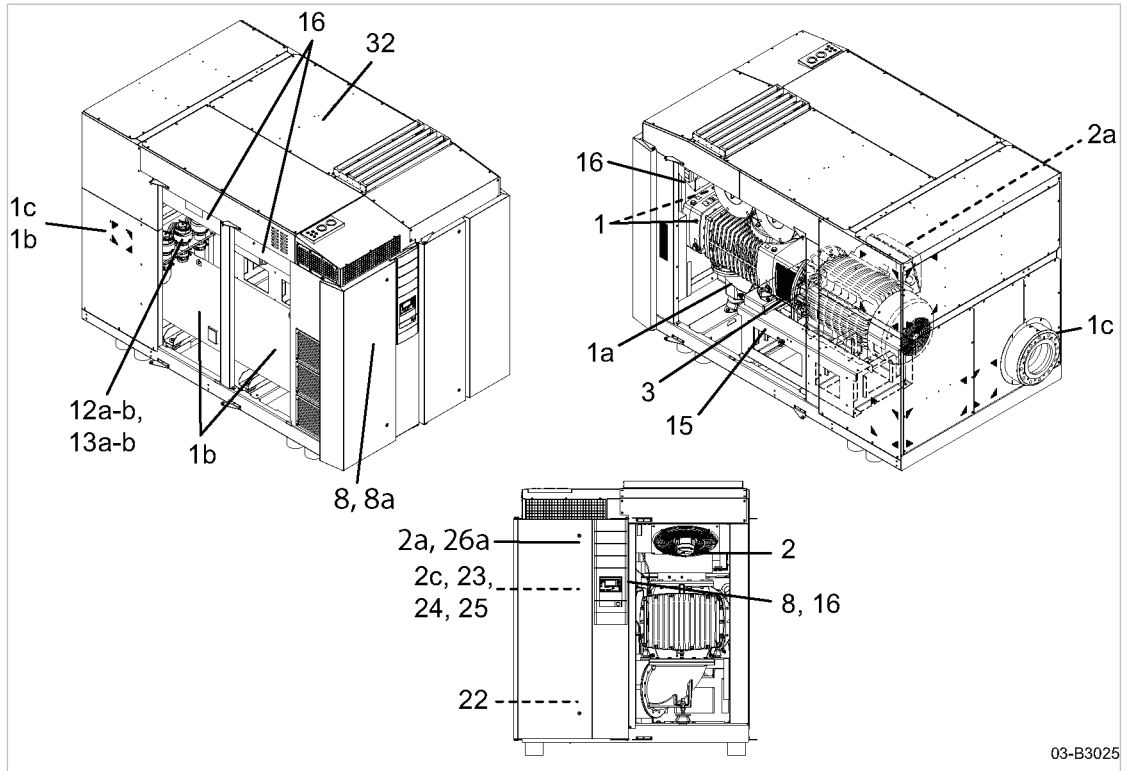

Fig. 3 Location of the safety signs on the machine

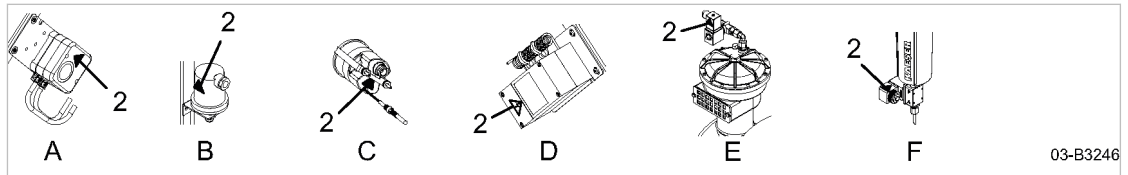















Fig. 4 Safety sign location, electronically activated components

- | | |
|--|----------------------------------|
| (A) Filter differential pressure switch | (D) Thermostat |
| (B) Pressure switch | (E) Magnetically activated valve |
| (C) Temperature display with switching point | (F) Oil chamber ventilation |

Location	Symbol	Meaning
1 1a 1b 1c		Hot surface can cause burns! ▶ Let the machine cool down. ▶ Wear long-sleeved garments (not synthetics such as polyester) and protective gloves.
2 2a 2c		Danger of fatal injury from touching electrically live components! ▶ Switch off and lock out / tag out the power supply disconnecting device and verify the absence of any voltage before opening any machine enclosure or guard.

Location	Symbol	Meaning
3		<p>Rotating rotors!</p> <p>Risk of serious lacerations or even severing of extremities (fingers) from rotating components.</p> <ul style="list-style-type: none"> ➤ Operate the machine only when a connection is made to the inlet port. ➤ Switch off and lock out / tag out the power supply disconnecting device and verify the absence of any voltage before opening any machine enclosure or guard.
8		<p>Personal injury or damage to the machine by incorrect operation!</p> <ul style="list-style-type: none"> ➤ Read and understand the service manual and all safety signs before switching on this machine.
8a		<p>Machine starts automatically!</p> <p>Severe injury can result from rotating components, electrical voltage, and air pressure.</p> <ul style="list-style-type: none"> ➤ Switch off and lock out / tag out the power supply disconnecting device and verify the absence of any voltage before opening any machine enclosure or guard.
12a-b		<p>Serious injury or death can result from loosening or opening component that is under pressure and heavily spring loaded!</p> <ul style="list-style-type: none"> ➤ Do not open or dismantle the valve. ➤ Contact an authorized KAESER service representative if a fault occurs.
13a-b		<p>Serious injury or death can result from loosening or opening component under pressure!</p> <ul style="list-style-type: none"> ➤ Depressurize all pressurized components and enclosures. ➤ Ensure the machine remains depressurized. ➤ Check that machine is depressurized.
15		<p>Injury and/or contamination can result from breathing compressed air! Contamination of food can result from using untreated compressed air for food processing!</p> <ul style="list-style-type: none"> ➤ Never breathe untreated compressed air. ➤ Air from this compressor must meet OSHA 29CFR1910.134 and FDA 21CFR178.3570 standards, if used for breathing or food processing. Use proper compressed air treatment.
16		<p>Noise due to opened service panel of the sound enclosure (Option H12)!</p> <ul style="list-style-type: none"> ➤ Hearing may be damaged. ➤ Wear hearing protection.
22		<p>High protective conductor current!</p> <p>Touching electrically live components can cause serious injury or death.</p> <ul style="list-style-type: none"> ➤ Switch off and lock out / tag out the power supply disconnecting device and check that no voltage is present. ➤ Wait at least 5 minutes. ➤ Verify the absence of any voltage.
23		<p>Danger of fatal injury from touching electrically live components!</p> <ul style="list-style-type: none"> ➤ Switch off and lock out / tag out the power supply disconnecting device and verify the absence of any voltage.

Location	Symbol	Meaning
24		<p>Risk of electric shock!</p> <ul style="list-style-type: none"> ➤ If the interrupter has tripped current-carrying components of the controller should be examined and replaced if damaged to reduce the risk of fire or electric shock.
25		<p>Risk of electric shock!</p> <ul style="list-style-type: none"> ➤ To maintain high current short-circuit, and ground-fault protection, the manufacturer's instructions for setting the interrupter must be followed to reduce the risk of fire or electric shock.
26a		<p>Danger of fatal injury from electrical voltage and charged capacitors!</p> <ul style="list-style-type: none"> ➤ Before starting any work on the electrical equipment: Switch off the power supply disconnecting device, lock out / tag out the device, verify the absence of any voltage. ➤ Following shutdown of the power supply disconnecting device, wait for 5 minutes before opening the control cabinet/connector box. ➤ Before starting work on the frequency converter or intermediate circuit capacitors, wait for at least 5 minutes.
32		<p>Risk of falling or damage to the machine as a result of applied load!</p> <ul style="list-style-type: none"> ➤ Do not sit or walk on the housing. ➤ Do not place or store any load on the housing.

Tab. 20 Safety signs

3.10 In emergency

3.10.1 Correct fire fighting

Suitable extinguishing agents

- Foam
- Carbon dioxide
- Sand or dirt

Unsuitable or unsafe extinguishing agents

- Strong jet of water

1. Keep calm.
2. Give the alarm.
3. Switch off the power supply disconnecting device, if possible.
4. Move to safety.
 - Warn persons in danger.
 - Help incapacitated persons.
 - Close the doors.
5. Try to extinguish the fire if you have the skill to do so.

3.10.2 Remove lubricating oil from the skin.

- Eye contact:
Rinse eyes thoroughly with lukewarm water and seek medical assistance.
- Skin contact:
Wash off immediately.

3.11 Environmental protection

- Store and dispose of operating materials and replaced parts in accordance with local environmental protection regulations.
- Observe national regulations.
This applies particularly to parts contaminated with lubricating oil.



- Do not allow lubricating oil to escape to the environment or into the sewage system.

3.12 Warranty

This operator manual contains no independent warranty commitment. Our general terms and conditions of business apply with regard to warranty.

A condition of our warranty is that the machine is used for the purpose for which it is intended under the conditions specified.

Due to the multitude applications for which the machine is suitable the obligation lies with the user to determine its suitability for his specific application.

In addition, we accept no warranty obligation for:

- the use of unsuitable parts or operating materials,
- unauthorized modifications,
- incorrect maintenance,
- incorrect repair.

Correct maintenance and repair includes the use of original spare parts and operating materials.

- Obtain confirmation from KAESER that your specific operating conditions are suitable.

4 Design and Function

4.1 Enclosure

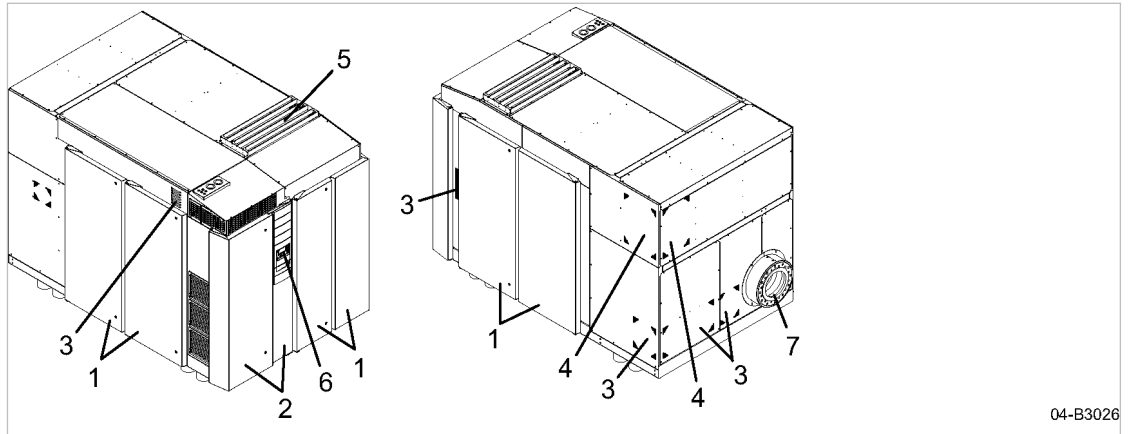

Fig. 5 Enclosure overview

- | | | | |
|---|----------------------|---|----------------------------|
| ① | Access door | ⑤ | Cooling air outlet |
| ② | Control cabinet door | ⑥ | Controller SIGMA CONTROL 2 |
| ③ | Cooling air inlet | ⑦ | Pressure line connection |
| ④ | Intake air inlet | | |

The motor fan draws cooling air through the cooling air inlet ③ into the sound enclosure to cool the drive motor and the machine.

Cooling air flow is supplemented by a fan inside the sound enclosure. The warm air is blown out in order to prevent the machine from overheating.

Air to be compressed is drawn in through the intake air inlet ④. This ensures that only air at ambient temperature is compressed.

The access doors ① of the sound enclosure can be opened.

The control cabinet doors ② can be swung open.

Latches are released by a key supplied with the machine.

The sound enclosure has several functions when it is closed:

- Sound insulation
- Protection against contact with components
- Airflow control

The sound enclosure is not suitable for the following uses:

- Persons walking, standing or sitting on the machine.
- Use as a resting place or storage of any kind of load.

4.2 SIGMA CONTROL 2 operating panel

4.2.1 Keys

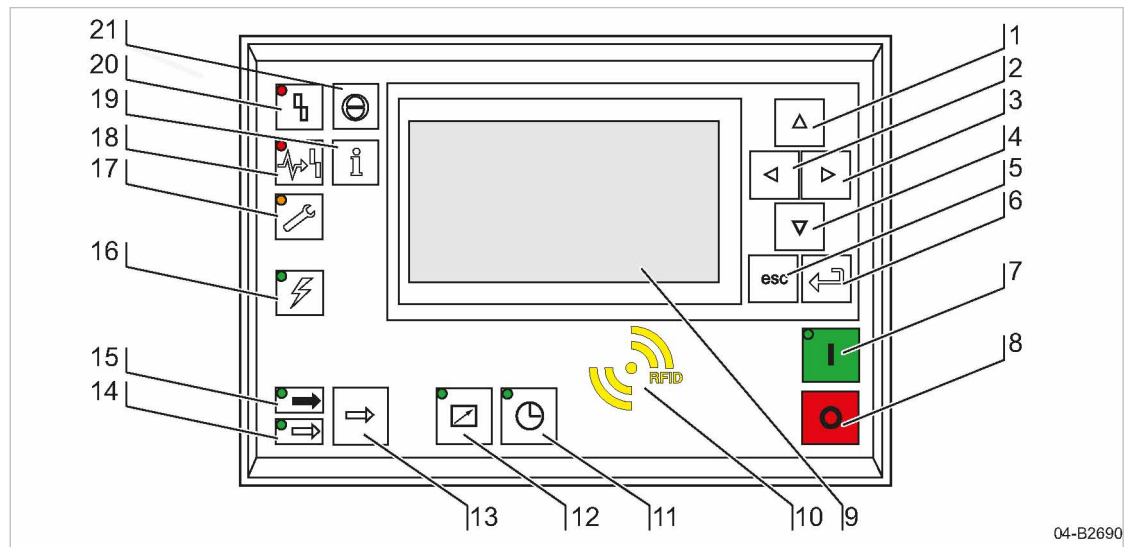

Fig. 6 Indicating and operating elements

Item	Name	Function
①	«Up»	Scrolls up the menu options. Increases a parameter value.
②	«Left»	Jumps to the left. Moves the cursor position to the next left field.
③	«Right»	Jumps to the right. Moves the cursor position to the next right field.
④	«Down»	Scrolls down the menu options. Reduces a parameter value.
⑤	«Escape»	Returns to the next higher menu option level. Exits the Edit mode without saving.
⑥	«Enter»	Jumps to the selected menu option. Exits the Edit mode and saves.
⑦	«ON»	Switches the machine on.
⑧	«OFF»	Switches the machine off.
⑩	RFID	RFID sensor field for user log-in with RFID Equipment Card.
⑪	«Timer control»	Switches timer control on and off.
⑫	«Remote control»	Switches remote control on and off.
⑬	«LOAD/IDLE»	Toggles between the LOAD and IDLE operating modes.
⑲	«Information & Events»	Displays the event memory.
⑳	«Reset»	Signifies recognition of alarms and warning messages. If permissible: Resets the fault counter (RESET).

Tab. 21 Controls

4.2.2 LEDs

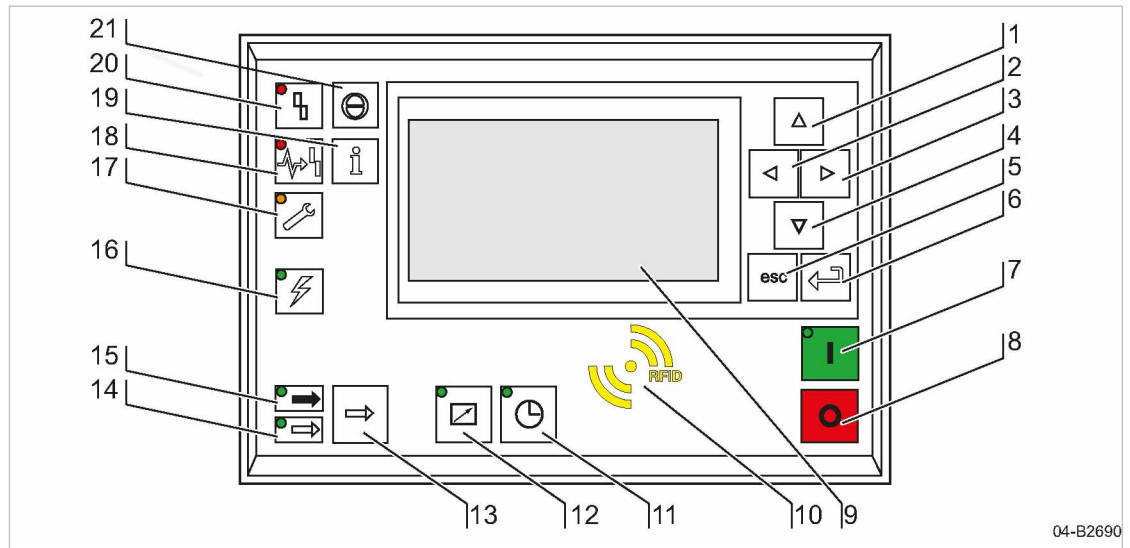

Fig. 7 Indicating and operating elements

Item	Name	Function
7	ON	Display illuminates green when the machine switched on.
9	Display	Graphic display with 8 lines and 30 characters per line.
11	Timer control	Continuous green light when the machine is controlled by the timer.
12	Remote control	Continuous green light when the machine is in remote control.
14	IDLE	Continuous green light when the machine is running in IDLE. Flashes when the «LOAD/IDLE» toggle key is pressed.
15	LOAD	Continuous green light when the machine is running in LOAD.
16	Controller on	Continuous green light when voltage is applied to the controller.
17	Warning	Flashes in yellow in the following events: <ul style="list-style-type: none"> ■ Maintenance necessary. ■ Warning message
18	Communications error	Continuous red light to indicate a faulty communication connection without machine shut-down.
20	Fault	Flashes red to indicate a machine fault. Continuous red light after acknowledgement.

Tab. 22 Display elements

4.2.3 RFID sensor field

RFID is the abbreviation for “Radio Frequency Identification” and enables the identification of persons or objects.

Placing a suitable transponder in front of the RFID sensor field of the controller will automatically activate the communication between transponder and SIGMA CONTROL 2.

A suitable transponder is the RFID Equipment Card. Two of them have been provided with the machine.

Typical application:

- Operators log on at the machine.
(Manual input of the password not required)



The RFID Equipment Cards are carefully packed in a plastic sleeve. This plastic sleeve is attached to the rear of the controller in the control cabinet.

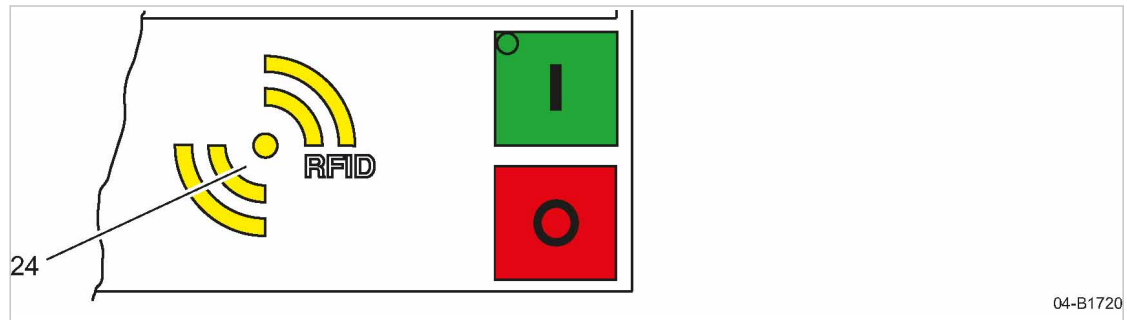

Fig. 8 RFID sensor field

Item	Name	Function
24	RFID	RFID sensor field for the communication with a RFID Equipment Card or RFID Key.

Tab. 23 RFID sensor field

Further information More information about the use of RFID technology is provided in the SIGMA CONTROL 2 operating manual.

4.3 Machine

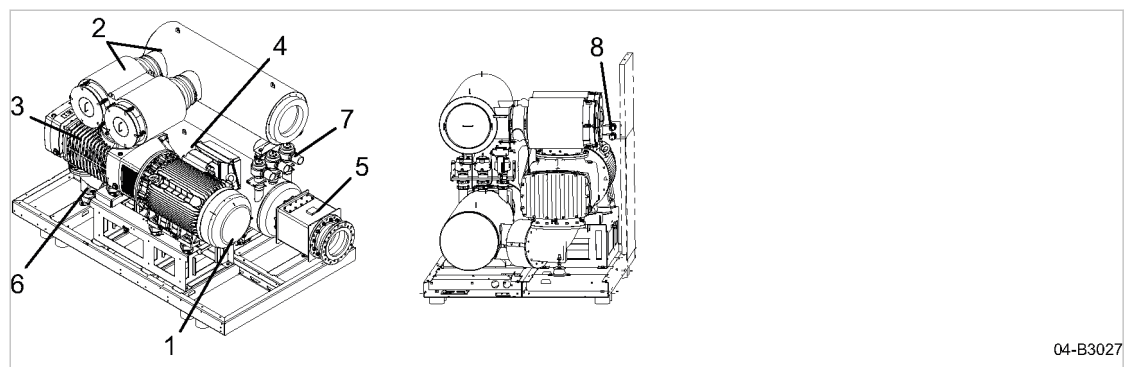

Fig. 9 Machine

- | | |
|-------------------|--------------------------------|
| ① Drive motor | ⑤ Check valve (Option G1) |
| ② Inlet silencer | ⑥ Manifold |
| ③ Blower block | ⑦ Safety relief valve |
| ④ Outlet silencer | ⑧ Automatic lubrication system |

The blower block ③ is driven by the drive motor ①.

Air is drawn into the inlet silencer ② and through an air filter where it is filtered.

The air is then pushed from the blower block in vertical direction via the manifold ⑥ into the outlet silencer ④, where the process forces pressure build-up.

4.4 Blower block

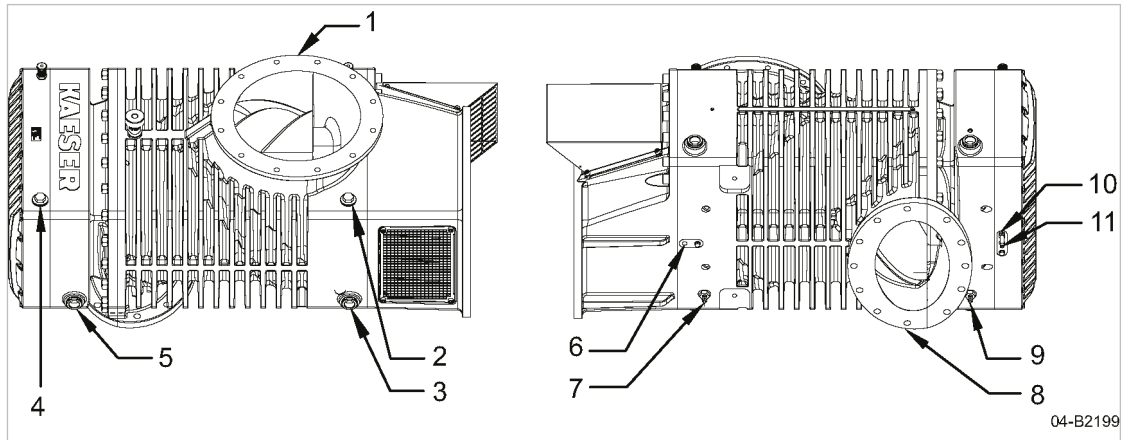

Fig. 10 Blower block

- | | | | |
|---|----------------------------------|---|----------------------------------|
| ① | Flange connection, intake side | ⑦ | Oil level monitoring, drive side |
| ② | Drive-end oil inlet | ⑧ | Discharge port connection |
| ③ | Drive-end oil sight glass | ⑨ | Oil level monitoring, gear side |
| ④ | Gear-end oil inlet | ⑩ | Oil temperature monitoring |
| ⑤ | Gear-end oil sight glass | ⑪ | Oil drain connection, gear side |
| ⑥ | Oil drain connection, drive side | | |

A pair of rotors with intermeshing lobes turn in opposite directions within a casing. The rotors are synchronized by timing gears on one end. Air in the block inlet is trapped between the rotors and the casing and moved round to the discharge port.

As there is no contact between the rotors themselves and the casing, oil film lubrication is not required.

4.5 Safety relief valve

The safety relief valve (blow-off valve) protects the system from excessive pressure. It is factory set.

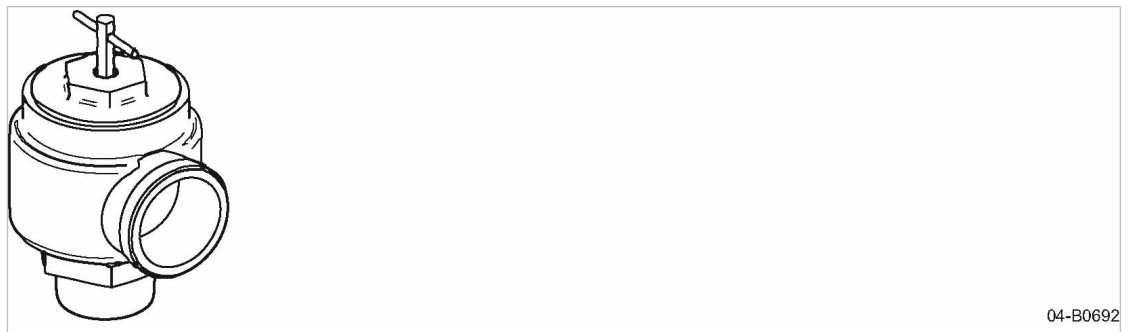

Fig. 11 Safety relief valve (blow-off valve)

4.6 Safety devices

The following safety devices are provided and may not be modified in any way.

- Safety relief valve:
The safety relief valve protects the machine from excessive pressure build-up. It is factory set.
- Covers over moving parts and electrical connections:
These protect against accidental contact.

4.7 Compensator

The compensator functions as follows:

- Inlet and outlet connections to silencers and accessories,
- Isolates the machine vibrations from the air pipeline.

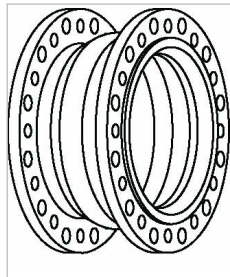

04-B0694

Fig. 12 Compensator

4.8 Automatic starting

Depending on the settings in the controller, the machine can automatically start after a power failure or external deactivation.

You must be logged in with the RFID Equipment Card in order to activate or deactivate this option.
Option deactivated (factory setting):

- Machine remains deactivated after a network power failure.

Option activated:

- Machine automatically restarts after the voltage supply has returned.

Further information Note the instructions in the operating manual supplied with SIGMA CONTROL 2 for activating and deactivating this function.

4.9 Automatic lubrication system

The motor bearings of the drive motor are re-lubricated by means of an automatic lubrication system. The grease is resupplied from a grease cartridge at regular intervals. The SIGMA CONTROL 2 controller defines the time for the grease supply.



The settings of the automatic lubrication system are preset and cannot be changed.

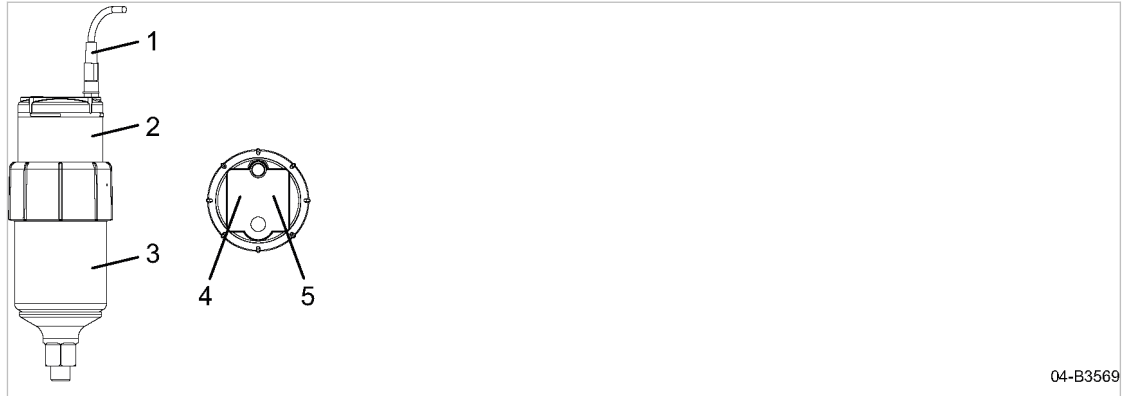

Fig. 13 Automatic lubrication system

- | | | | |
|---|-----------------------|---|--|
| ① | Cable | ④ | Display of the number of remaining grease impulses / fault message |
| ② | Actuator with display | ⑤ | Display of the quantity per impulse |
| ③ | Grease cartridge | | |

04-B3569

4.10 Floating relay contacts

Floating relay contacts are provided for the transfer of operational state (messages). Information on location, loading capacity, and type of contact can be found in the electrical diagram.



If the floating relay contacts are connected to an external voltage source, voltage may be present even when the machine is isolated from the power supply.

4.11 Options

The options available for your machine are described below.

4.11.1 Option C5 Oil level monitor

The oil level switch monitors the lubricant level of the blower block.

Two float-type level sensors monitor the level of oil in the drive and gear-end oil chambers. If the oil level falls below the minimum level, a switching contact is opened.

The controller registers the signal, displays an alarm message and shuts down the machine.

4.11.2 Option C39 Oil temperature monitoring

The Pt100 sensor of the oil temperature monitoring continuously records the lubricant temperature at the gear side of the blower block. The machine controller evaluates the sensor. Two threshold values are pre-set.

When these threshold values are reached, the controller displays a warning or alarm message:

- Warning message at a lubricant temperature of $\geq 239^{\circ}\text{F}$, the machines does **not** shut down.
- Alarm message at a lubricant temperature of $\geq 266^{\circ}\text{F}$, the machine shuts down.

This warning or alarm message is provided as a group message for external analysis.

4.11.3 Option C52 Electrical connection: bottom



The foundation plan is included in the dimensional drawing in chapter 13.2.

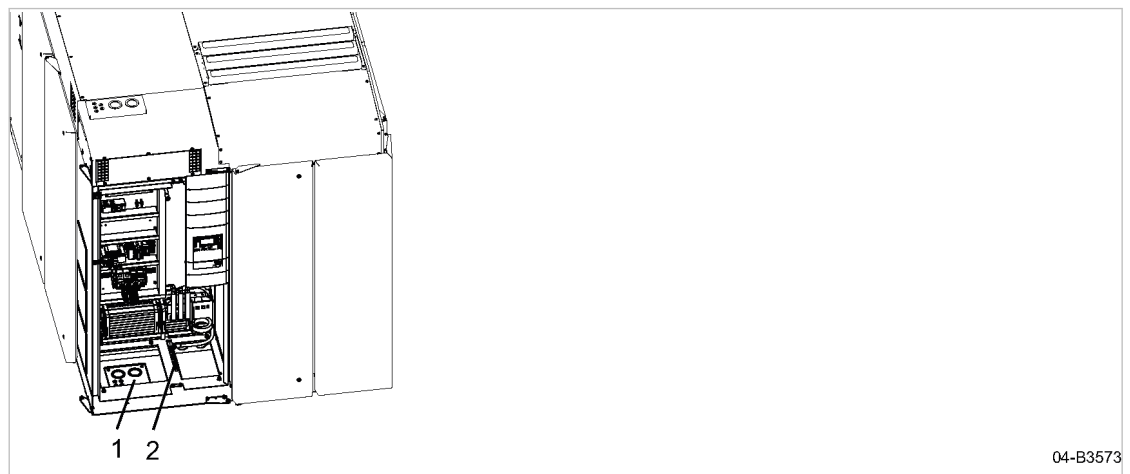

Fig. 14 Electrical connection: bottom

- ① Cable bushing
- ② PE rail

A cut-out with a cable bushing ① in the basic frame and an additional PE rail ② is provided in the bottom area for the electrical connection.

Further information The connection diagram in chapter 13.4 contains further details about the electrical connection.

4.11.4 Option G1 Check valve

The check valve prevents the reversal of the intended air flow direction.

The valve is closed when the machine is at standstill.

The connecting screws are secured by means of adhesive.

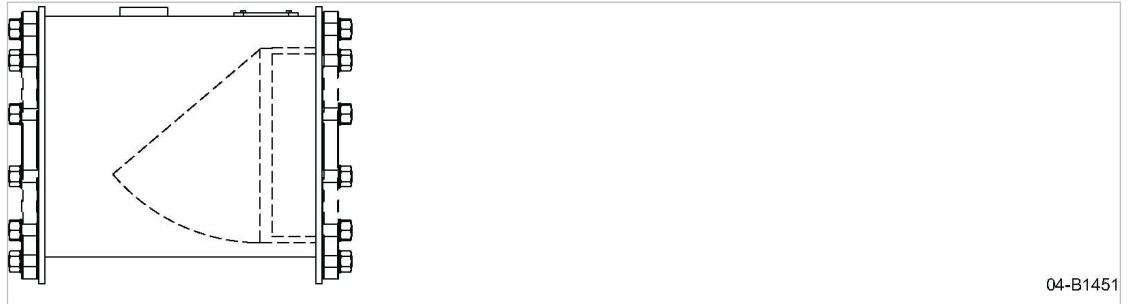

04-B1451

Fig. 15 Non-return flap

4.11.5 Option H11 Piped inlet

Air is drawn into the block through the inlet silencer.

5 Installation and Operating Conditions

5.1 Ensuring safety

The conditions in which the machine is installed and operated have a decisive impact on safety. Warning instructions are located before a potentially dangerous task.



Disregard of warning instructions can cause serious injuries!

Complying with safety instructions

Disregard of safety warnings can cause unforeseeable dangers!

- Strictly forbid fire, open flame and smoking.
- If welding is carried out on or near the machine, take adequate measures to prevent sparks or heat from igniting oil vapors or parts of the machine.
- Do not store flammable material in the vicinity of the machine.
- The machine is not explosion-proof!
Do not operate in areas in which specific requirements with regard to explosion protection are in force.
- Ensure sufficient and suitable lighting such that the display can be read and work carried out comfortably and safely.
- Keep suitable fire extinguishing agents ready for use.
- Comply with the permissible ambient and intake conditions.
- Ensure the correct composition of the intake air:
 - Clean with no damaging contaminants (e.g., dust, fibers, fine sand).
 - Free of explosive or chemically unstable gases or vapors.
 - Free of acid/alkaline forming substances, particularly ammonia, chlorine or hydrogen sulfide.

Noise

The sound enclosure absorbs and reduces the machine noise to a comfortable level. This function will be effective only if the sound enclosure is closed.

- If necessary, wear hearing protection or take hearing protection measures on-site.

5.2 Installation conditions

5.2.1 Determining installation location and clearances

The machine is intended for installation in a suitable machine room. Information on wall clearances and ventilation is given below.



The clearances specified are recommended clearances and ensure unhindered access to all machine parts.

- Please consult KAESER if you cannot comply with these recommendations.

Precondition The floor must be level, firm and capable of bearing the weight of the machine. No special foundations are necessary.

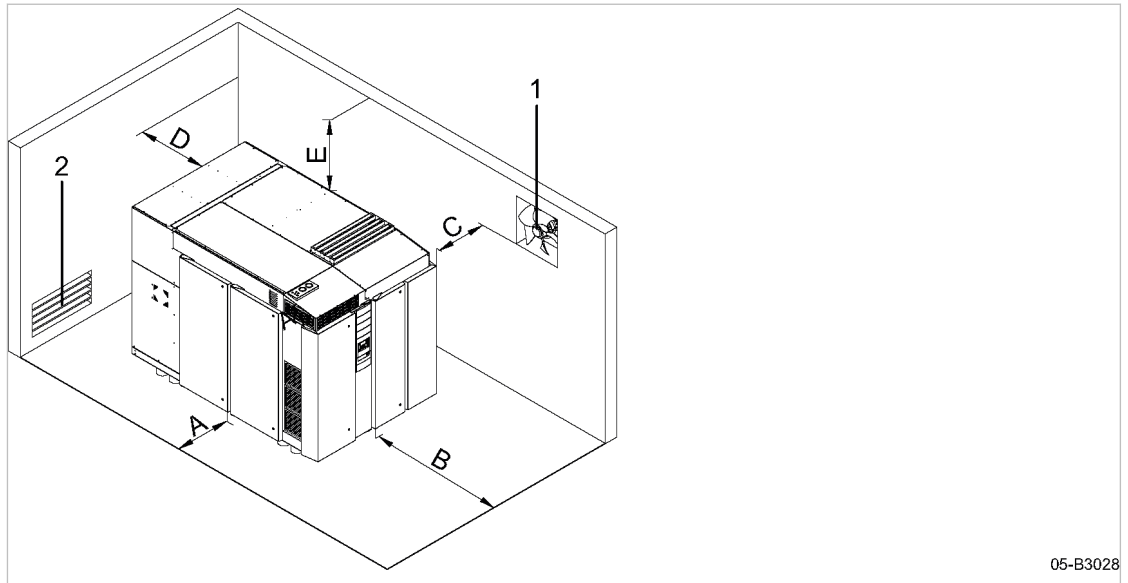

05-B3028

Fig. 16 Recommended positioning of the machine, minimum dimensions [in.]

A	32.0	E	59.1
B	78.7	1	Exhaust fan
C	32.0 or 78.7	2	Ventilation inlet air opening
D	39.4		

- Clearance **C**):
32.0 in. with hoist above the machine or
78.7 in. for hoist required at side of the machine.
- If the ambient temperature is too low: Ensure that the compressor room is adequately heated.
- Ensure accessibility so that all work on the machine can be carried out hazard-free and without obstruction.
- Do not position the machine in the hot exhaust air flow from other machines.
- When installing multiple machines, ensure that all inlet and exhaust air openings are arranged on one side.
- Observe any additional clearances that may be specified in local occupational health & safety and building regulations, so that escape and rescue routes may safely be accessed, even when the machine housing is open.

5.2.2 Ensuring adequate ventilation



If the ventilation is insufficient, a partial vacuum can be created in the machine room.

- Ensure that the flow rate of inlet air is at least the same as the flow rate taken by the machine and exhaust fan from the machine room.
- Ensure that a sufficient amount of oxygen is available for any individuals entering the machine room.
- Ensure that the machine and exhaust fan can only be operated when the air inlet opening is open.
- Keep the inlet and exhaust openings free from obstructions so that the cooling air can flow freely through the machine room.

6 Installation

6.1 Ensuring safety

Follow these instructions to ensure safe installation.

Warning instructions are provided prior to any potentially dangerous task.



Disregarding warning instructions can result in life-threatening injuries!

Observing safety instructions

Ignoring safety instructions can result in unforeseen dangers.

- Follow the instructions in chapter 3 "Safety and Responsibility".
- Installation work must only be carried out by authorized personnel!
- Ensure that no personnel are working on the machine.
- Ensure that all panels are closed.

Working on live components

Touching live components can result in electric shocks, burns or death.

Dangerous voltages remain in the frequency converter and intermediate circuit capacitors for some time after the power has been disconnected.

When the frequency converter is open, live components are exposed.

- Work on electrical equipment may only be carried out by authorized electricians.
- Switch off the power supply disconnecting device, lock out / tag out the device, verify the absence of any voltage.
- Before starting work on the frequency converter or intermediate circuit capacitors, wait for at least 5 minutes.
- Check that there is no voltage on floating contacts.

Working on the compressed air system

Compressed air is stored energy. Uncontrolled release of this energy can cause serious injury or death. The following safety instructions relate to any work on components that might be pressurized.

- Switch off the power supply disconnecting device, lock out / tag out the device, verify the absence of any voltage.
- Close shut-off valves or otherwise isolate the machine from the compressed air network so as to ensure that no compressed air can flow back into the machine.
- Fully vent all pressurized components and enclosures.
- Do not open or dismantle any valves.

Working on the drive system

Touching live components can result in electric shocks, burns or death.

Touching the fan wheel while the machine is switched on can result in serious injury.

- Switch off the power supply disconnecting device, lock out / tag out the device, verify the absence of any voltage.
- Do not open any of the panels while the machine is switched on.

Further information Information regarding authorized personnel can be found in chapter 3.4.2.
Information regarding dangers and their avoidance can be found in chapter 3.5.

6.2 Reporting transport damage

1. Check the machine for visible and hidden transport damage.
2. Inform the carrier and the manufacturer in writing of any damage without delay.

6.3 Align the blower block and secure the machine

Suitable fixings are delivered with the machine.



The foundation plan is included in the dimensional drawing in chapter 13.2.

1. Open the access doors.

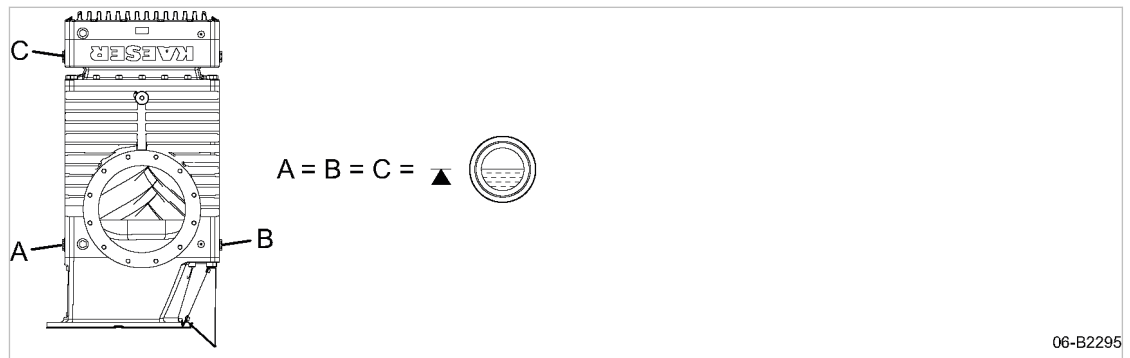

Fig. 17 Blower block (top view)

- (A) Drive-end oil sight glass
- (B) Drive-end oil sight glass
- (C) Gear-end oil sight glass

2. Visually inspect the lubricant levels in the oil sight glasses (A), (B) and (C).
3. If necessary, use blocks to horizontally align the lubricant levels of the oil sight glasses.
4. Use appropriate fixing bolts to anchor the machine to the floor and prevent it from shifting.
5. Close access doors.

6.4 Connecting the power supply

- Precondition** The power supply disconnecting device is switched off, lock out and tag out the device, the absence of any voltage has been verified. The tolerance limits of the power supply are within the tolerance limits of the rated machine voltage.
- Option C38, SIGMA FREQUENCY CONTROL (SFC):
The voltage in the intermediate circuit capacitors of the frequency converter is reduced.
1. The power supply must only be connected by authorized installation personnel or authorized certified electricians.
 2. Carry out protection measures as stipulated in relevant regulations and in national accident prevention regulations. In addition, observe the regulations of the local electricity supplier.
 3. Select supply cable conductor cross—sections and fusing in accordance with local regulations and chapter 2.11.
 4. Test the overcurrent protective device to ensure that the time it takes to shut down in response to a fault is within the permitted limit.
 5. The user is required to fit the machine with a lockable power supply disconnecting device. This could be, for example, a load disconnect switch with fused input. If a circuit breaker is used it must be suitable for the motor starting characteristics.
 6. Check that the control transformer is connected according to the supply voltage. If not, reconnect the control transformer to suit the power supply voltage.
 7. **⚠ DANGER** *Danger of fatal injury from electric shock!*
 - *Switch off and lock out the power supply disconnecting device and verify the absence of voltage.*
 8. Connect the machine to the power supply.
 9. Properly close openings, cable glands, etc.
- Further information** The wiring diagram in chapter 13.4 contains further details of the power supply connection.

Connecting the control cabinet

The machine can be operated at full power at the rated voltage with a tolerance of $\pm 5\%$.

If the supply voltage deviates from the rated voltage, the control transformer's (component T11) cable bridge should be changed to correspond to the actual main power supply.

1. Select supply cable conductor cross—sections and fusing in accordance with local regulations and chapter 2.11.
2. Connect the control cabinet (note clockwise phase rotation!).

6.4.1 Option C32 Under frequency control



If the machine is delivered by KAESER including the frequency converter, the regulation behavior and operating mode of the frequency converter will be preset.

- Adapt and optimize the actual properties to the customer system on-site.

- Comply with the following provisions if you operate machines with a frequency converter:
 - Operate the machine only within its performance limits and under the permitted ambient conditions.
 - The speed change should be approx. 5 Hz per second. This value applies also for the starting ramp from standstill to reaching minimum frequency. Deviating settings, either slower or faster, may be possible after verification by an authorized KAESER SERVICE representative.
 - The frequency converter may be switched to a motor in standstill only, in order to avoid malfunctions.
 - The automatic restart of the machine is **not** preset for safety-relevant reasons.

6.5 Making the compressed air connection

Material Torque wrench

Precondition The machine is factory assembled and ready for use up to the point of connection to the discharge silencer.
The compressed air network is completely depressurized.

⚠ WARNING

Serious injury or death can result from loosening or opening components under pressure!

- Fully vent all pressurized components and enclosures.



A non-return valve or check valve must be installed in systems in which overpressure remains after the machine has been shut down to allow for unloaded starting of the machine.

- Consult an authorized KAESER service representative regarding a suitable check valve and professional installation.
1. Use a flexible connector to create the air connection to the piping system or the consumer and install, complying with the torques specified below:

Connection to customer's piping	Tightening torque [lbf-ft]
Compressor with hose clamps	—
Compressor with screwed joint M20*	66.4

* Manually tighten screws equally, pretension crosswise at 37 lbf-ft and subsequently retighten crosswise with torque according to table.

Tab. 24 Compensator torques at discharge side

2. Support the weight of the pipework and any other connecting components.

Option H12 Sound enclosure

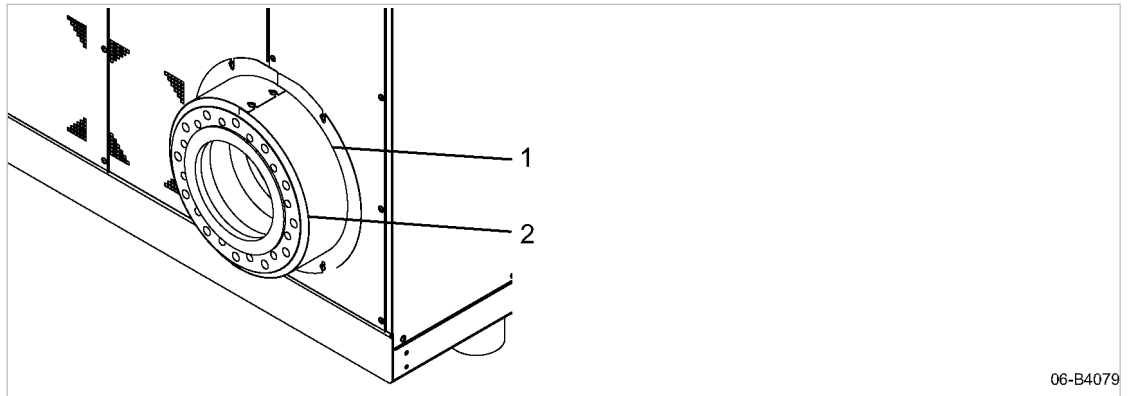

Fig. 18 Assembling the two collar halves

- ① Collar half
- ② Compensator

➤ Tightly position the supplied collar halves ① around the compensator ② of the port ends and screw to the sound enclosure.

**6.6 Option H11
Connecting the inlet pipeline**

If suction is to be from a pipeline, the inlet silencer is connected using a compensator.

Material Torque wrench

Precondition The compressed air system is vented completely to atmospheric pressure.

1. Connect to the compressed air system using the following torques:

Connection to an customer's pipeline	Torque [lbf-ft]
Compressor with hose clamps	—
Compressor with screwed joint M20*	66.4

* Manually tighten screws equally, pretension crosswise at 37 lbf-ft and subsequently retighten crosswise with torque according to table.

Tab. 25 Inlet compressor torques

2. Separately secure the inlet pipelines upstream of the compensator.

Further information The dimensional drawing in chapter 13.2 provides information regarding the connection of the pipeline.

**6.7 Option H12
Sound enclosure: Installing the exhaust air ducting**



With Option H11 (Intake from the pipeline), installing the exhaust air ducting is not applicable.

Due to its height for transportation, exhaust air ducting must be installed onto the sound enclosure afterwards.

The exhaust air ducting is supplied with the machine. Install after the machine is set up.

Material Wrench
Exhaust air ducting

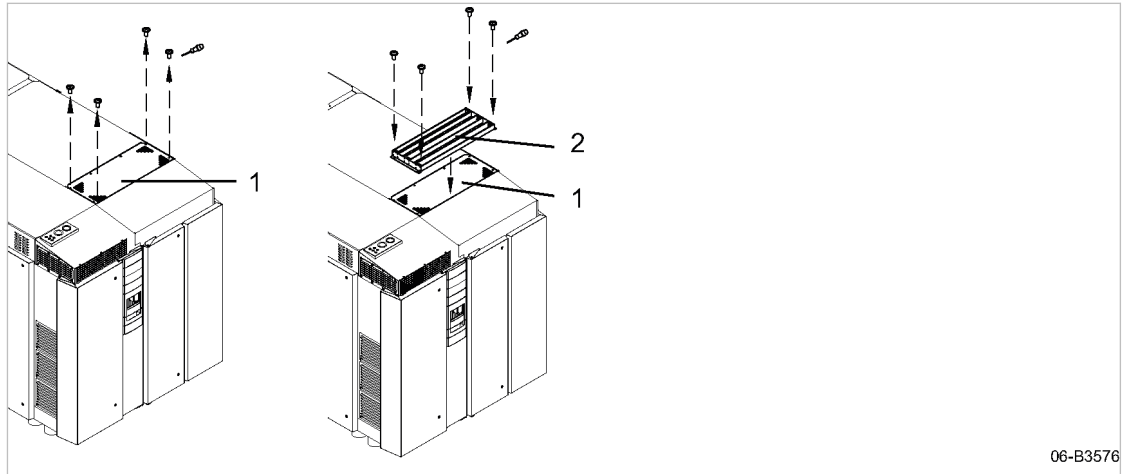

06-B3576

Fig. 19 Installing the exhaust air ducting

- ① Sound enclosure cover
- ② Exhaust air ducting

1. Remove existing screws on the cover of the sound enclosure ①, do not remove the cover.
2. Install exhaust air ducting ② onto the cover of the sound enclosure with the available screws.

7 Initial Start-up

7.1 Ensuring safety

This chapter provides instructions for safe commissioning of the machine. Warning instructions are provided prior to any potentially dangerous task.



Disregarding warning instructions can result in life-threatening injuries!

Observing safety instructions

Ignoring safety instructions can result in unforeseen dangers.

- Follow the instructions in chapter 3 “Safety and Responsibility”.
- Commissioning tasks may only be carried out by authorized installation personnel!
- Ensure that no personnel are working on the machine.
- Ensure that all panels are closed.

Working on live components

Touching live components can result in electric shocks, burns or death.

Dangerous voltages remain in the frequency converter and intermediate circuit capacitors for some time after the power has been disconnected.

When the frequency converter is open, live components are exposed.

- Work on electrical equipment may only be carried out by authorized electricians.
- Switch off the power supply disconnecting device, lock out / tag out the device, verify the absence of any voltage.
- Before starting work on the frequency converter or intermediate circuit capacitors, wait for at least 5 minutes.
- Check that there is no voltage on floating contacts.

Working on the compressed air system

Compressed air is stored energy. Uncontrolled release of this energy can cause serious injury or death. The following safety instructions relate to any work on components that might be pressurized.

- Switch off the power supply disconnecting device, lock out / tag out the device, verify the absence of any voltage.
- Close shut-off valves or otherwise isolate the machine from the compressed air network so as to ensure that no compressed air can flow back into the machine.
- Fully vent all pressurized components and enclosures.
- Do not open or dismantle any valves.

Working on the drive system

Touching live components can result in electric shocks, burns or death.

Touching the fan wheel while the machine is switched on can result in serious injury.

7 Initial Start-up

7.2 Instructions to be observed before commissioning

- Switch off the power supply disconnecting device, lock out / tag out the device, verify the absence of any voltage.
- Do not open any of the panels while the machine is switched on.

Further information Information regarding authorized personnel can be found in chapter 3.4.2.
 Information regarding dangers and their avoidance can be found in chapter 3.5.

7.2 Instructions to be observed before commissioning

Incorrect or improper commissioning can cause injury to persons and damage to the machine.

- Commissioning may be carried out only by authorized installation and service personnel who have been trained on this machine.

Special measures for recommissioning after storage/standstill

Storage period/ standstill longer than	Measure
12 months	<ul style="list-style-type: none"> ➤ Change the lubricating oil. ➤ Have the motor bearings re-greased by an authorized KAESER service representative. ➤ Have the frequency converter intermediate circuit capacitors formed (refreshed) by an authorized KAESER service representative.
24 months	<ul style="list-style-type: none"> ➤ Change the grease cartridge. ➤ Have the motor grease changed by an authorized KAESER service representative.
36 months	<ul style="list-style-type: none"> ➤ Have the overall technical condition checked by an authorized KAESER service representative.

Tab. 26 Recommissioning after storage/standstill

7.3 Checking installation and operating conditions

- Check and confirm all the items on the checklist before commissioning the machine.

To be checked	See chapter	Complied with?
➤ Have all packing materials, tools and transport securing devices been removed from the machine?	—	
➤ Are the operators completely familiar with the safety regulations?	—	
➤ Have all the positioning conditions been complied with?	5	
➤ Is the machine anchored to the floor without stress?	6.3	
➤ Are the tolerance limits of the power supply within the permissible tolerance limits of the rated machine voltage?	—	
➤ Are the cable cross-sections and fuse ratings adequate?	2.11	

* Not applicable to Option H11, intake from pipeline

To be checked	See chapter	Complied with?
➤ Is a user-supplied lockable power supply disconnecting device installed?	6.4	
➤ Has the control cabinet connection been checked?	6.4	
➤ Has a suitable check valve been installed professionally?	6.5	
➤ Has the connection to the air network been made with a flexible hose or compensator?	6.5	
➤ Has the direction of rotation of the drive motor and fan (sound enclosure) been checked?	7.6	
➤ Have all electrical connections checked for tightness?	—	
➤ Is there adequate lubricating oil in the gear and drive end of the blower block? (Lubricating level center of oil sight glass)	10.5	
➤ Has exhaust air ducting of sound enclosure been installed? (Option H12) *	6.7	
➤ Are all access doors of sound enclosure closed and latched and removable panels are in place and secured? (Option H12)	4.1	

* Not applicable to Option H11, intake from pipeline

Tab. 27 Installation conditions check list

7.4 Configuring the controller

- Configure the controller as described in the SIGMA CONTROL 2 operating manual.

7.5 Setting the display language

The controller can display message text in several languages.

You can set the language for texts on the display. This setting will be retained even when the machine is switched off.

1. In operating mode, switch to the main menu with the «Enter» key.
2. Press the «UP» or «DOWN» keys until the current language is shown as active line:

6.1 bar	80.0 °C	
Deutsch		Current language (active line)
➤1 xxxxxxxxxx		Submenu
➤2 xxxxxxxxxx		Submenu
➤3 xxxxxxxxxx		Submenu
➤4 xxxxxxxxxx		Submenu
➤5 xxxxxxxxxx		Submenu
➤6 xxxxxxxxxx		Submenu

3. Use the «Enter» key to switch to setting mode.
The language display flashes.

4. Move to the required language with «UP »or «DOWN».
5. Confirm the setting with the «Enter» key.

Result The display texts are now in the selected language.

Further information Detailed information can be found in the SIGMA CONTROL 2 operating manual.

7.6 Checking the direction of rotation for the drive motor

The machine is designed for a clockwise phase sequence.

If the direction of rotation is incorrect, the flow direction will be reversed and air drawn in from the compressed air line.

A phase sequence relay is installed in the machine control cabinet, which only sends a release signal to the controller when a clockwise direction of rotation is detected.

The controller will report a fault if the direction of rotation is counter-clockwise. In this case, interchange phases L1 and L2 of the supply line(s). The fault can then be acknowledged.

Material Phase sequence indicator

NOTICE

Incorrect direction of rotation!

This may result in damage to the machine from intake of foreign articles or excessive vacuum.

➤ *Ensuring the correct direction of rotation.*

1. Remove the filter maintenance cover from the inlet silencer or inlet filter and/or remove the check valve on the inlet side.
2. Verify the direction of rotation using a phase sequence indicator.
3. If the direction of rotation is incorrect, exchange phases L1 and L2 of the supply lines.



If you do not have access to a phase sequence indicator:

➤ Arrange for the phase sequence to be checked by an authorized KAESER service representative.

7.7 Starting the machine for the first time

Precondition No personnel are working on the machine.
The control cabinet's door is closed and locked.
All maintenance doors and panels are in place and secured.

1. Allow the machine to cool to ambient temperature before switching on for the first time to avoid the build up of condensation.
2. Switch on the power supply disconnecting device.
After the controller has carried out a self-test, the green *Control voltage* LED is lit continuously.
3. If required:
Change the display language as described in chapter 7.5.
4. Press the «ON» key.
The green *IDLE* LED is lit continuously.
The drive motor runs up.



- Watch for any faults occurring in the first hours of operation.
- After the first 50 operating hours, check all electrical connections and tighten where necessary.

8 Operation

8.1 Switching on and off

Always switch the machine on with the «ON» key and off with the «OFF» key.
A power supply disconnecting device has been installed by the user.

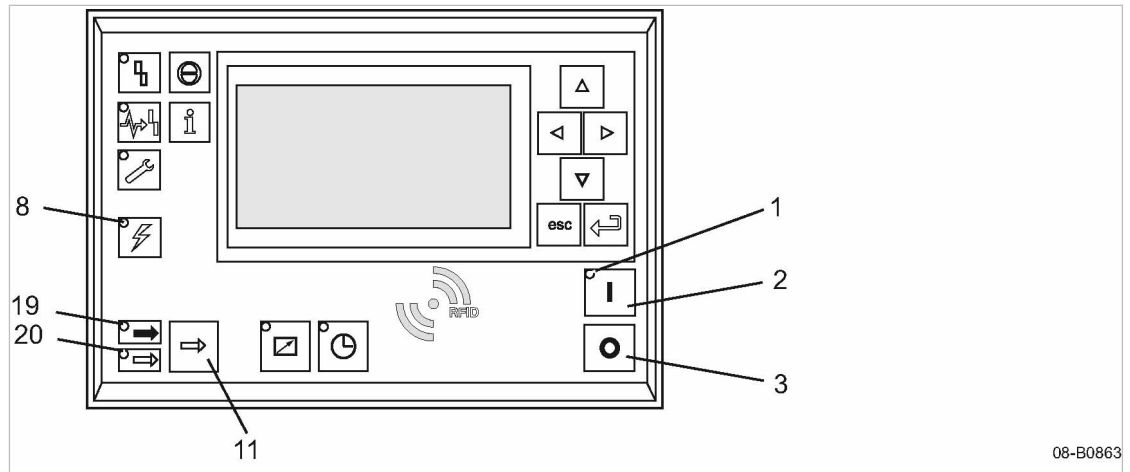

Fig. 20 Switching the machine on and off

- | | | | |
|---|------------------------|---|------------------------|
| ① | ONLED | ⑪ | «LOAD/IDLE» toggle key |
| ② | «ON» key | ⑲ | LOADLED |
| ③ | «OFF» key | ⑳ | IDLELED |
| ⑧ | Controller voltage LED | | |

8.1.1 Switching on

Precondition No personnel are working on the machine.

No personnel inside the machine.

All access doors of sound enclosure are closed and the removable panels are in place and latched.

1. Switch on the power supply disconnecting device.
The *Controller voltage* LED lights green.
2. Press the «ON» key.
The *ON*LED lights green.



Option C38, SIGMA FREQUENCY CONTROL (SFC)
Maximum frequency of motor starts per hour: any.

Automatic restart

If a power failure occurs, the machine is **not** prevented from automatically restarting when power is resumed.

It can automatically restart as soon as power is restored.

- Note the instructions in the User Manual supplied with SIGMA CONTROL 2 for activating and deactivating this function.

8.1.2 Switching off

1. Press the «OFF» key.

When the machine switches to IDLE (based on the configuration of the machine), and during the fan run-on time, the *ON*LED flashes. The *ON*LED extinguishes as soon as the automatic shut-off action is completed.

2. Switch off and lock out the power supply disconnecting device.

Result The *Controller voltage* LED extinguishes. The machine is switched off and disconnected from the power supply.



In rare cases, you may want to shut down the machine immediately and cannot wait until the automatic shut-down process is finished.

- Press «OFF» once again.

8.2 Switching off in an emergency and switching on again

The EMERGENCY STOP push-button is located to the right next to the control panel.

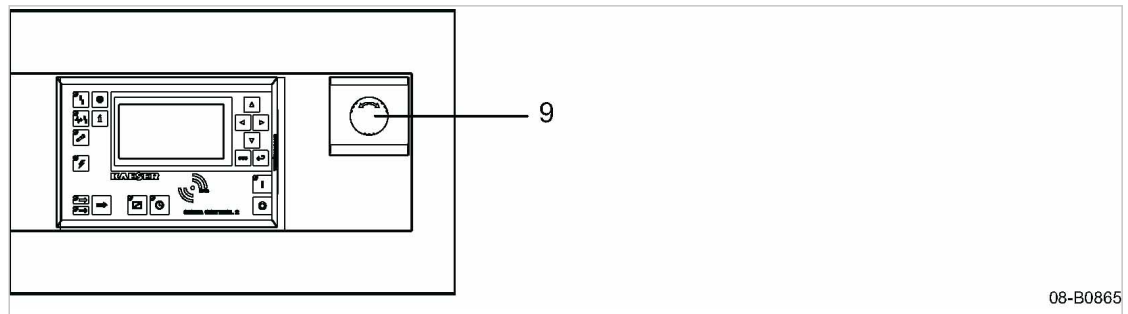

08-B0865

Fig. 21 Switching off in an emergency

- ⑨ EMERGENCY STOP push button

Switching off

- Press the EMERGENCY STOP push button.

Result The EMERGENCY STOP push button remains latched after actuation.
The machine is secured against an automatic restart.

Switching on

Precondition The fault has been rectified.

1. Turn the EMERGENCY STOP push button in the direction of the arrow to unlatch it.
2. Acknowledge any existing fault messages.

Result The machine can now be started again.

8.3 Switching on and off from a remote control center

Precondition A link to the remote control center exists.

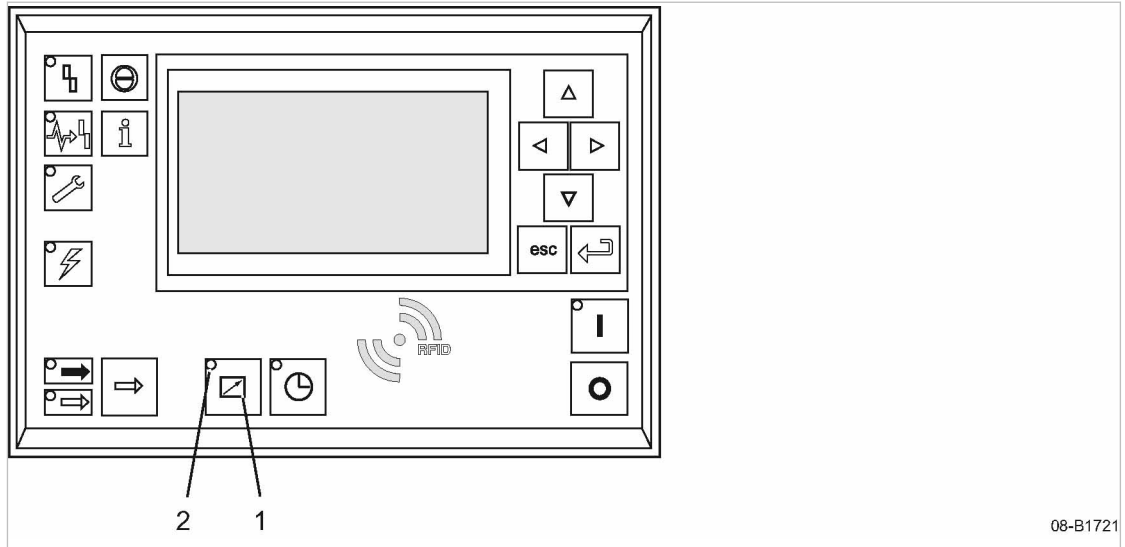

Fig. 22 Switching on and off from a remote control center

- ① «Remote control» key
- ② *Remote control* LED

1. Attach an easily seen notice to the machine that warns of remote operation.

⚠ WARNING

Remote control: Risk of injury caused by unexpected starting!

- Make sure that the power supply disconnecting device is switched off before commencing any work on the machine.

Tab. 28 Machine identification

2. Label the starting device in the remote control center as follows:

⚠ WARNING

Remote control: Risk of injury caused by unexpected starting!

- Before starting, make sure that no one is working on the machine and that it can be safely started.

Tab. 29 Remote control identification

3. Press the «Remote control» key.

Result The *Remote control* LED lights. The machine can be remotely controlled.

8.4 Switching on and off with the clock (timer)

Precondition The clock is programmed.

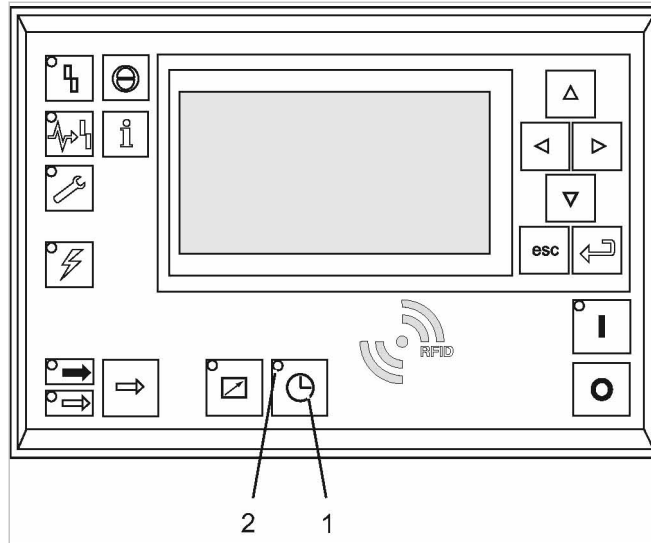

08-B1722

Fig. 23 Switching on and off with the clock (timer)

- ① «Timer control» key
- ② *Timer control* LED

1. Attach an easily seen notice warning of time-controlled operation:

⚠ WARNING

Time control: Risk of injury caused by unexpected starting!

- Make sure that the power supply disconnecting device is switched off before commencing any work on the machine.

Tab. 30 Machine identification

2. Press «Timer control».

Result The *Timer control* LED lights. The machine is switched on and off by the clock (timer).

8.5 Option H12

Checking the ventilator fan function (sound enclosure)

NOTICE

Overheating inside the sound enclosure!

A standstill of the ventilator can result in a breakdown of the blower block or other components.

- *If the ventilator stops, immediately provide an alternative flow of cooling air through the sound enclosure.*
- Check that air is actually being blown out of the enclosure cooling air outlet, e.g. by holding a sheet of paper in front of the outlet.

Further information An authorized KAESER service representative can advise on suitable measures.

8.6 Interpreting operation messages

The controller will automatically display operation messages informing you about the current operational state of the machine.

Operating messages are identified with the letter B.

Further information Detailed information can be found in the SIGMA CONTROL 2 operating manual.

8.7 Acknowledging alarm and warning messages

Messages are displayed on the "new value" principle:

- Message coming: LED flashes
- Message acknowledged: LED illuminates
- Message going: LED off

or

- Message coming: LED flashes
- Message going: LED flashes
- Message acknowledged: LED off

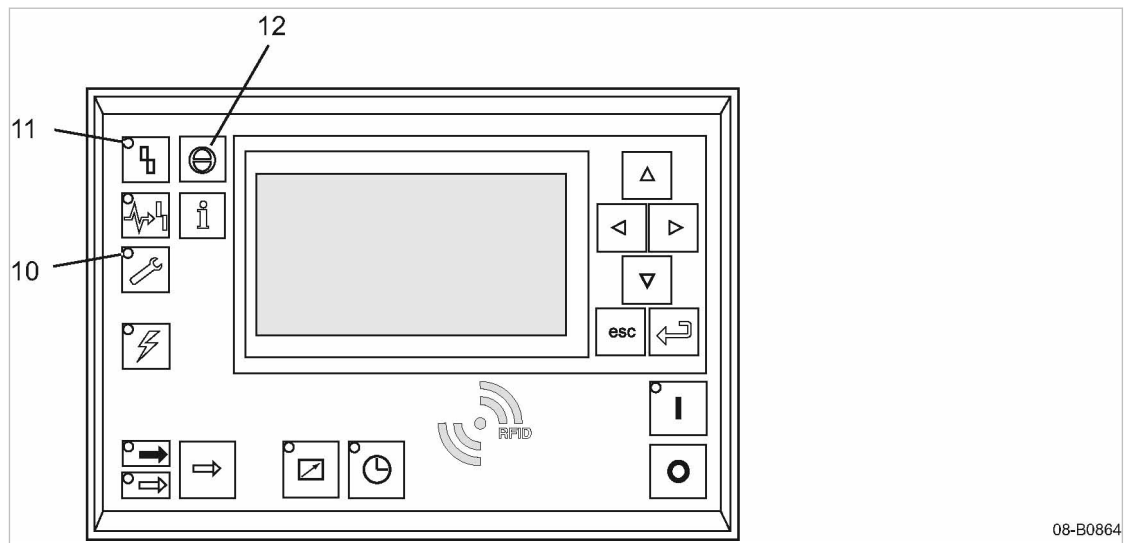

Fig. 24 Acknowledging messages

- 10 Warning LED (yellow)
- 11 Alarm LED (red)
- 12 «Acknowledge» key

Alarm message

An alarm shuts the machine down automatically. The red *Alarm* LED flashes. The system displays the appropriate message.

Precondition The fault has been rectified.

- Acknowledge the message with the «Acknowledge» key.
The *Alarm* LED extinguishes.
The machine is again ready for operation.



If the machine was switched off with the EMERGENCY STOP button:

- Unlatch the EMERGENCY STOP button (turn in direction of the arrow) before acknowledging the alarm message.

Further information Please refer to the SIGMA CONTROL 2 operating manual for a list of possible fault messages during operation.

Warning message

If maintenance work is to be carried out or if the warning is displayed before an alarm, the yellow *Warning* LED flashes.

The system displays the appropriate message.

Precondition The danger of an alarm is passed, maintenance has been carried out.

- Acknowledge the message with the «Acknowledge» key.
The *Warning* LED extinguishes.

Further information Please refer to the SIGMA CONTROL 2 operating manual for a list of possible warning messages during operation.

9 Fault Recognition and Rectification

9.1 Basic instructions

Fault messages are classified in various categories:

- Warning:
 - Warning messages *W*
- Fault (with indication):
 - Alarm messages *S*
 - System messages *Y*
 - Diagnostic messages *D*
- Other faults (without indication): See chapter 9.2

The messages valid for your machine are dependent on how the individual machine is equipped.

1. Do not attempt fault rectification measures other than those given in this manual!
2. In all other cases:
Have the fault rectified by an authorized KAESER SERVICE representative.

Further information See the operating manual of SIGMA CONTROL 2 for details regarding the various messages.

9.2 Other faults

Fault	Possible cause	Remedy
Unusual noise when running.	Too much backlash in the timing gears.	Contact an authorized KAESER service representative.
	Too much play in the rotor bearings.	Contact an authorized KAESER service representative.
	Rotors not synchronized.	Maintain the pressure differential and speed shown in the specification. Contact an authorized KAESER service representative.
Blower block runs too hot.	Pressure differential too great.	Check and correct pressure differential.
	Clogged inlet filter reducing air intake volume.	Clean the inlet filter.
	Rotor plays too high.	Contact an authorized KAESER service representative.
	Leakage due to incorrect installation of pressure-bearing components.	Contact an authorized KAESER service representative.
Oil leaks from the gas drain.	Oil level too high.	Drain off lubricating oil until the correct level is reached.
Oil leaking from around the drive shaft.	Sliding ring seal defective.	Contact an authorized KAESER service representative.
Low intake flow volume.	Intake resistance too high.	Clean the inlet filter.

Fault	Possible cause	Remedy
Black film on the oil sight glasses.	Oil not changed at the correct interval.	Change the lubricating oil. Clean or renew the sight glass.
	Insufficient lubricating oil.	Change the lubricating oil. Clean or renew the sight glass.
	Oil overheated.	Contact an authorized KAESER service representative.
	Blower airend overloaded.	Contact an authorized KAESER service representative.
Water in the oil.	Condensate build-up by prolonged storage and high humidity.	Change the lubricating oil.
Safety relief valve activates.	Inadmissible operating state, operating pressure too high.	Bring the machine to a permissible operational state or shut down.

Tab. 31 Other faults and remedies

9.3 Option H12 Sound enclosure faults

Alarm	Possible cause	Remedy
Overheating inside the sound enclosure!	Fan defective or turning in the wrong direction.	Check connection. Contact an authorized KAESER service representative.
	Flow of cooling air blocked.	Check and clean cooling air apertures. Check the cooling air inlet temperature.
	Drive motor overloaded.	Check operating conditions.
	Leakage due to incorrect installation of pressure-bearing components.	Contact an authorized KAESER service representative.

Tab. 32 Faults and remedies (option H12)

10 Maintenance

10.1 Ensuring safety

Follow the safety instructions below to ensure safe maintenance of the machine. Warning instructions are provided prior to any potentially dangerous task.



Disregarding warning instructions can result in life-threatening injuries!

Observing safety instructions

Ignoring safety instructions can result in unforeseen dangers.

- Follow the instructions in chapter 3 “Safety and Responsibility”.
- Allow maintenance work to be performed by authorized personnel only!
- Ensure that no personnel are working on the machine.
- Ensure that all panels are closed.

Working on live components

Touching live components can result in electric shocks, burns or death.

Dangerous voltages remain in the frequency converter and intermediate circuit capacitors for some time after the power has been disconnected.

When the frequency converter is open, live components are exposed.

- Work on electrical equipment may only be carried out by authorized electricians.
- Switch off the power supply disconnecting device, lock out / tag out the device, verify the absence of any voltage.
- Before starting work on the frequency converter or intermediate circuit capacitors, wait for at least 5 minutes.
- Check that there is no voltage on floating contacts.

Working on the compressed air system

Compressed air is stored energy. Uncontrolled release of this energy can cause serious injury or death. The following safety instructions relate to any work on components that might be pressurized.

- Switch off the power supply disconnecting device, lock out / tag out the device, verify the absence of any voltage.
- Close shut-off valves or otherwise isolate the machine from the compressed air network so as to ensure that no compressed air can flow back into the machine.
- Fully vent all pressurized components and enclosures.
- Do not open or dismantle any valves.

Working on the drive system

Touching live components can result in electric shocks, burns or death.

Touching the fan wheel while the machine is switched on can result in serious injury.

- Switch off the power supply disconnecting device, lock out / tag out the device, verify the absence of any voltage.
- Do not open any of the panels whilst the machine is switched on.

Further information Information regarding authorized personnel can be found in chapter 3.4.2.
Information regarding dangers and their avoidance can be found in chapter 3.5.

10.2 Maintenance schedule

10.2.1 Logging maintenance work



- The maintenance intervals given are those recommended for average operating conditions.
- Maintenance tasks should be carried out more frequently where operating conditions are unfavorable (e.g. dusty atmosphere) or when the equipment is in constant use.
 - Adjust the maintenance intervals with regard to local installation and operating conditions.
- Keep a log of all maintenance and service work.
This enables the frequency of individual maintenance tasks and deviations from our recommendations to be determined.

Further information A prepared list is provided in chapter 10.14.

10.2.2 Resetting maintenance interval counters

Depending on the way a machine is equipped, sensors and/or maintenance interval counters monitor the operational state of important functional devices. Required maintenance work is shown on the SIGMA CONTROL 2.

Precondition Maintenance performed and,
Maintenance message acknowledged.

- Reset the maintenance interval counter as described in the SIGMA CONTROL 2 operating manual.

10.2.3 Regular maintenance tasks

The table below lists the required maintenance tasks.



- If operating conditions are unfavorable (e.g. dusty ambient) or if the equipment is in constant use, maintenance tasks must be carried out more frequently (shorter intervals).
- Carry out maintenance tasks in a timely manner, taking the ambient and operating conditions into consideration:

Interval	Maintenance task	See chapter
At least 50 hours after initial commissioning	Check that all electrical connections are secure and tighten if necessary.	–
Weekly	Control cabinet: Check the filter mat.	10.3

h = operating hours

Interval	Maintenance task	See chapter
Up to 500 h Or monthly	Check the air filter.	10.8
	Control cabinet: Clean the filter mat.	10.3
Up to 1000 h	Clean the machine.	10.9
Up to 3000 h, At least once a year	Change the FGB-680 lubricating oil.	10.7
Annually	Check the safety relief valve.	10.12
	Check the EMERGENCY STOP push button.	10.13
	Check that all electrical connections are secure and tighten if necessary.	–
	Automatic lubrication system: Check the messages on the grease cartridge display.	10.10.3
	Check the coupling.	10.11
Up to 6000 h, At least every 2 years	Control cabinet: Change the filter mat.	10.3
	Change the air filter.	10.8
	Automatic lubrication system: Change the grease cartridge.	10.10.3.2
Up to 6000 h, At least every 2 years	Change the G-680 lubricating oil.	10.7

h = operating hours

Tab. 33 Regular maintenance tasks

10.2.4 Regular maintenance tasks

The table below lists necessary maintenance tasks.

- Maintenance tasks should only be carried out by an authorized KAESER service representative.
- Arrange for maintenance tasks to be carried out in a timely manner, taking ambient and operating conditions into account:

Interval	Maintenance task
Up to 12000 h At least every 4 years	Oil chamber ventilation: Check the solenoid valve and replace the filter cartridge.
Up to 36000 h	Frequency converter fan: Replace the fan.
	Control cabinet fan: Replace the fan.
	Sound enclosure fan: Replace the fan.
	Oil chamber ventilation: Replace the solenoid valve.

h = operating hours

Interval	Maintenance task
Up to 36000 h At least every 4 years	Automatic lubrication system: Change the battery.
Up to 36000 h Every 8 years at the latest	Option G1, service the check valve. Change the coupling. Service the safety relief valve.
Up to 60000 h	Drive motor bearings with re-lubrication capability: Replace the motor bearings.
Up to 60000 h At least every 10 years	Replace the compensators. Oil chamber ventilation: Replace the vacuum pump.
After 20 years at the latest	Replace safety-relevant components for safety functions.

h = operating hours

Tab. 34 Regular maintenance tasks

10.3 Control cabinet: Clean or replace the filter mats

A filter mat is placed behind every ventilation grill. Filter mats protect the control cabinet from ingress of dirt. If the filter mats are clogged, adequate cooling of the components is no longer ensured. In such a case, clean or replace the filter mats.

Material Warm water with household detergent
Spare part (as required)
Wrench

Precondition The power supply disconnecting device is switched off, lock out and tag out the device, verify the absence of any voltage.

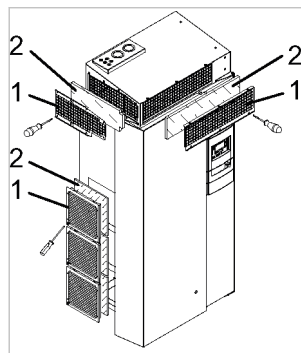

10-B3029

Fig. 25 Control cabinet ventilation

- ① Ventilation grill
- ② Filter mat

1. Carefully remove the ventilation grill ① and remove the filter mat ②.
2. Beat the mat or use a vacuum cleaner to remove loose dirt. If necessary, wash with lukewarm water and household detergent.

3. Replace the filter mat if cleaning is not possible or if the change interval has expired.
4. Install the filter mat in the frame and latch in the ventilation grill.

10.4 Option H12 Sound enclosure

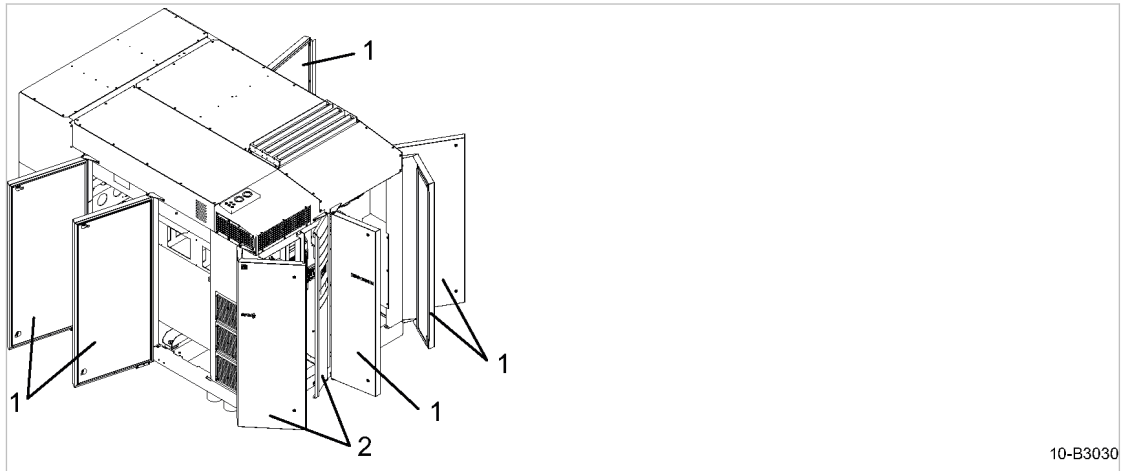

Fig. 26 Sound enclosure

- ① Access doors
- ② Control cabinet door

➤ Remove the access doors ① and open the control cabinet door ②, if necessary.



Use the key supplied with the machine to open the latches.

10.5 Checking the oil level

The true oil level can be seen in the oil sight glass only when the machine is stopped.



The gear-end and drive-end oil chambers are not connected.

⚠ WARNING

Danger of burns from hot components!

- *Wear long-sleeved clothing and protective gloves.*

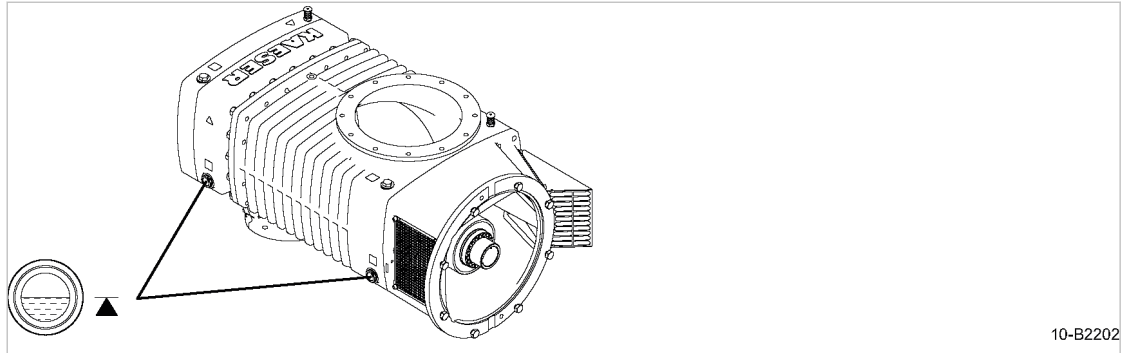

Fig. 27 Checking the oil level

1. Check the oil level in the sight glasses on both ends of the block.
2. Add lubricating oil as soon as the level falls 0.2 in. below the center of the sight glass.

10.6 Replenishing lubricating oil

Labels giving the oil type for topping off can be found at the corresponding inlet ports at the blower block.



Prior to any work requiring the opening of the pressure system, the machine must be fully isolated from the compressed air network and completely depressurized.

Material Wrench
Lubricating oil

Precondition The power supply disconnect device is switched off,
lock out and tag out the device,
verify the absence of any voltage,
the lubricating oil level has settled.

⚠ WARNING

Danger of burns from hot components and oil!

- *Wear long-sleeved garments and protective gloves.*

NOTICE

Unsuitable lubricating oil can damage the blower block!

- *Never mix different types of oil.*
- *Never top off with a different type of oil to that already used in the blower block.*

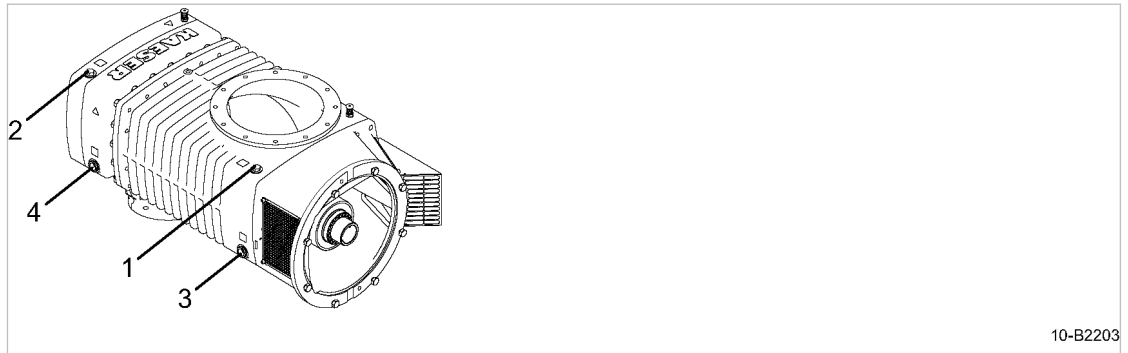

Fig. 28 Replenishing lubricating oil

- | | |
|-----------------------|-----------------------------|
| ① Drive-end oil inlet | ③ Drive-end oil sight glass |
| ② Gear-end oil inlet | ④ Gear-end oil sight glass |

1. Use the wrench to slowly open oil inlet ① and/or ② .
2. Top off until the level is in the center of the sight glass ③ and/or ④.
3. Close oil inlet ① and/or ②, tighten nuts with the wrench.
4. Visually check for leaks.

10.7 Changing the lubricating oil

The following sequence must be maintained:

1. Return the oil chamber ventilation lubricating oil.
2. Change the blower block lubricating oil.

10.7.1 Returning the oil chamber ventilation lubricating oil

During the ventilation of the blower block oil chambers, lubricating oil is separated and collects in the filter housing of the oil chamber ventilation. The return process is initiated by activating a menu item of the SIGMA CONTROL 2 controller.

Precondition The machine is ready to be switched on or running, password access level 2 has been activated, the operation display is shown.

1. Open the *<Maintenance>* menu.
2. Use the «Up» or «Down» keys to select the *<Oil Service>* line.
3. Press «Enter».
The check box will flash.
4. Press the «Up» key.
The check box is activated.
5. Press the «Enter» key.
<Oil service> is activated.

Result Collected lubricating oil from the oil chamber ventilation filter housing is returned to the control-side oil chamber of the blower block. The return process takes approx. 3 min and ends when the check-mark in the check box is extinguished.

Further information Press «Escape» repeatedly to leave this menu.

10.7.2 Changing the blower block lubricating oil



Prior to any work requiring the opening of the pressure system, the machine must be fully isolated from the compressed air network and completely depressurized.

Drain lubricating oil at an block temperature of at least 77°F to ensure sufficiently low viscosity.

Drain the oil thoroughly from the blower block:

- Gear-end
- Drive-end

Material Wrench
Lubricating oil
Lubricating oil receptacle

Precondition Oil chamber ventilation lubricating oil has been returned, the power supply disconnecting device is switched off, lock out and tag out the device, verify the absence of any voltage.

⚠ WARNING

Danger of burns from hot components and oil!

➤ *Wear long-sleeved garments and protective gloves.*

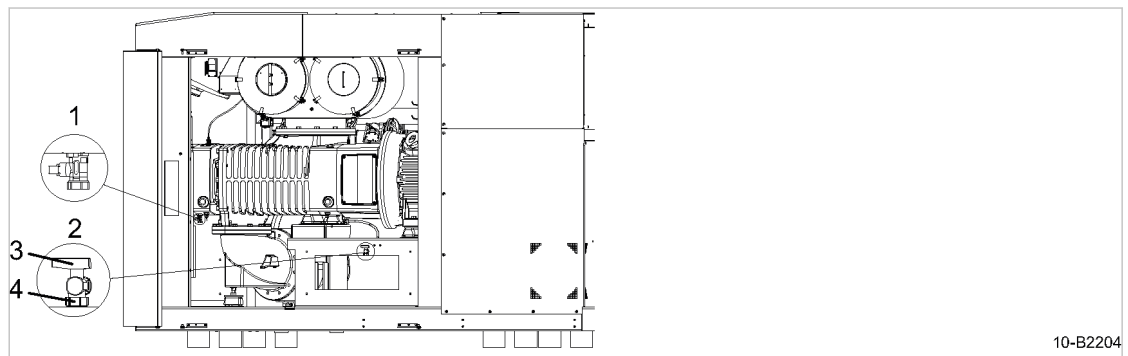

10-B2204

Fig. 29 Changing the lubricating oil

- | | |
|------------------------------|-----------------|
| ① Gear-end oil drain device | ③ Oil drain tap |
| ② Drive-end oil drain device | ④ Cap |

Draining the lubricating oil

1. Prepare an oil receptacle.
2. Use the wrench to slowly open the oil inlets of the gear and drive end, items ① and ② in Fig. 28.
3. Screw off caps ④ of gear and drive end, secure against reclosing and ensure that the oil can flow freely.
4. Open oil drain valves ③ and let lubricating oil drain out.



Dispose of the old lubricating oil in accordance with local environmental protection regulations.

Filling with fresh lubricating oil

1. Fill with fresh lubricating oil.
2. Allow the lubricating oil drain taps to remain open until lubricating oil begins to run out (bleeding the lubricating oil drain lines).
3. Close the lubricating oil drain taps (3) at the gear and drive end.
4. Top off lubricating oil until the level is in the center of each oil sight glass.
5. Screw on the caps (4) at the control and drive end.
6. Close oil inlets, tighten nuts with the wrench.
7. Visually check for leaks.

10.8 Air filter maintenance

The air filter protects the supplied pressure system from dirt entering.

NOTICE

Machine damage caused by unsuitable air filter!

The use of an unsuitable air filter can permit dirt to enter the pressure system and cause damage to the machine.

- *Use a suitable air filter.*



The air filter cannot be cleaned.

10.8.1 Changing the air filter

The machine must be isolated from the compressed air network and completely vented before undertaking any work on the pressure system.

Material Spare part

Precondition The power supply disconnecting device is switched off, lock out and tag out the device, verify the absence of any voltage.

⚠ WARNING

Danger of burns from hot components!

- *Wear long-sleeved garments and protective gloves.*

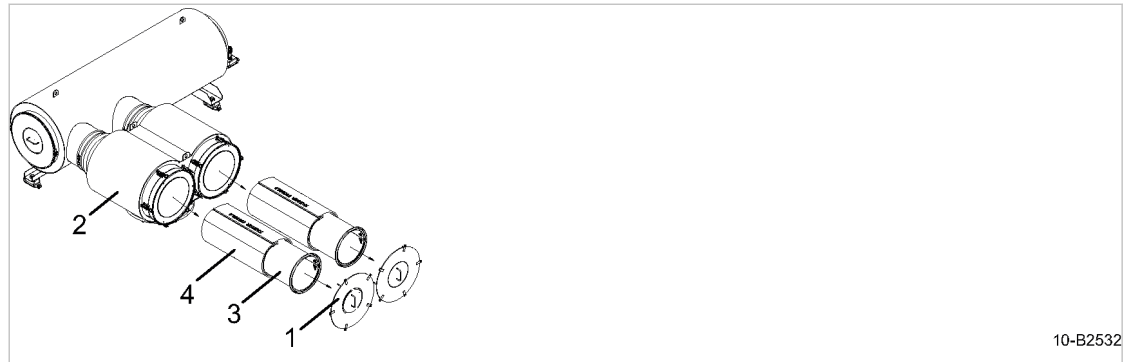

10-B2532

Fig. 30 Changing the air filter

- | | | | |
|---|----------------|---|-------------|
| ① | Cover | ③ | Filter cage |
| ② | Inlet silencer | ④ | Air filter |

1. Open the snap fasteners on the cover ① of the inlet silencer ②.
2. Remove the cover and pull out the filter cage ③ with the air filter ④.
3. Loosen the hook and loop tape and remove the air filter ④.
4. Clean all parts and sealing surfaces.
5. Place the new air filter around the perforated inlet port and secure with the hook and loop tape.
6. Attach the cover to the inlet silencer.

10.9 Machine cleaning

Regularly clean the machine. This ensures reliable cooling of the machine. The frequency is mainly dependent on local operating conditions.



Clogged machines are indicative of unfavorable ambient conditions. Such ambient conditions clog the cooling air ducts in the machine's interior and the motors resulting in increased wear and tear.

Material Brush and/or compressed air
 Protective gloves
 Face mask and safety goggles (if required)
 Vacuum cleaner

Precondition The power supply disconnecting device is switched off,
 the device is locked off,
 the absence of any voltage has been verified.
 The machine has cooled down.

1. Open the sound enclosure (Option H12).
 Dismantle panels in order to clean the cooling air ducts of the drive motor.
2. Dry brush the machine or blow off with compressed air.
3. Vacuum off dirt.
4. Close sound enclosure (Option H12).
 Replace and lock panels.



The machine cannot be cleaned?

- Have severe clogging removed by an authorized KAESER service representative.

10.10 Motor maintenance

10.10.1 Drive motor bearings

The motor bearings are automatically re-lubricated. Manual re-greasing is not necessary.

- The motor bearings must be replaced in the course of regular service calls by an authorized KAESER service representative.

Further information For further information regarding the motor, please consult the motor manual.

10.10.2 Fan motor

The motor bearings are permanently lubricated. Re-greasing is not necessary.

- The fan must be replaced in the course of regular service calls by an authorized KAESER service representative.

10.10.3 Servicing the automatic lubrication system

The display on the actuator indicates the necessary service and maintenance tasks.

1. **⚠ WARNING** *Noise from running machine when the maintenance door of the sound enclosure (Option H12) is open!*
Hearing may be damaged.
 - Always wear ear protection.
2. **⚠ WARNING** *Danger of burns from hot components!*
 - Wear long-sleeved garments and protective gloves.
3. Proceed with caution.

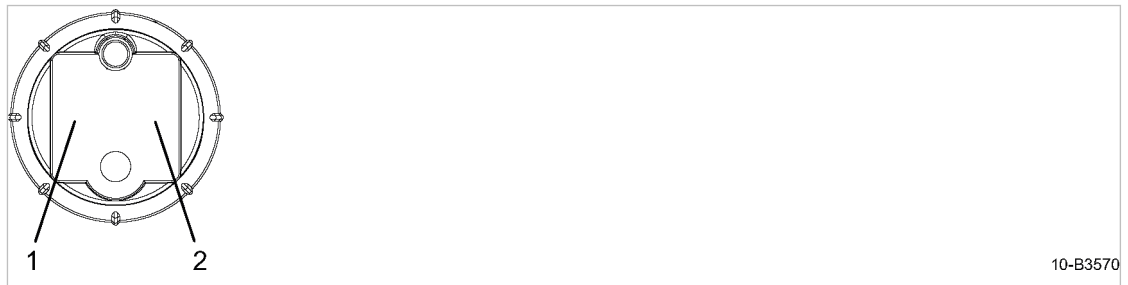

Fig. 31 Actuator display

- ① Number of lubrication impulses remaining indicator / fault message
- ② Quantity per impulse indicator

- Check the indicator on the actuator display.

Indicator	Function
LC	Illuminates immediately the grease cartridge requires changing.
LO	Illuminates immediately the battery in the actuator requires changing.
No indicator	If the indicator is extinguished, the battery must be replaced.

Tab. 35 Automatic lubrication system indicator

10.10.3.1 Replacing the battery

- Arrange for the battery to be replaced during the course of regular servicing by an authorized KAESER service representative.

Further information Information regarding the disposal of old batteries can be found in chapter 12.5.1.

10.10.3.2 Changing the grease cartridge

Material Spare part

Precondition The power supply disconnecting device is switched off, lock out and tag out the device, verify the absence of any voltage.

⚠ WARNING

Danger of burns from hot components!

- *Wear long-sleeved garments and gloves.*

Checking the fill date of the grease cartridge



A label with the fill date is attached to the grease cartridge.

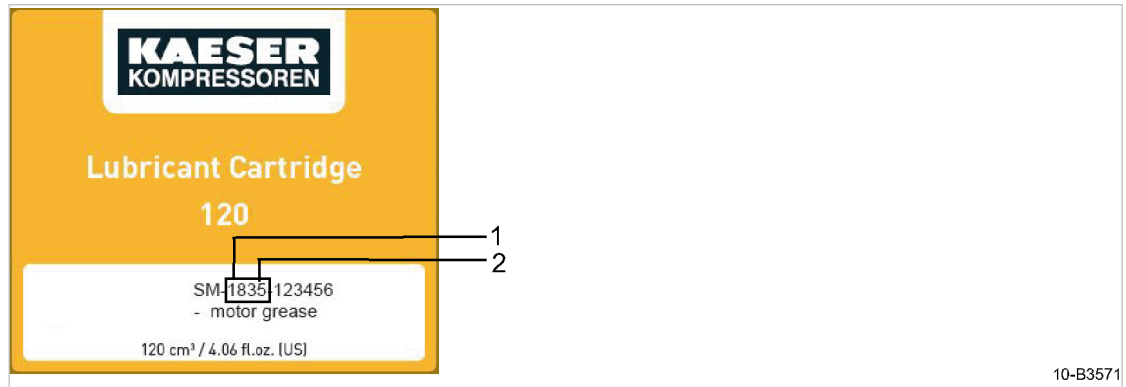
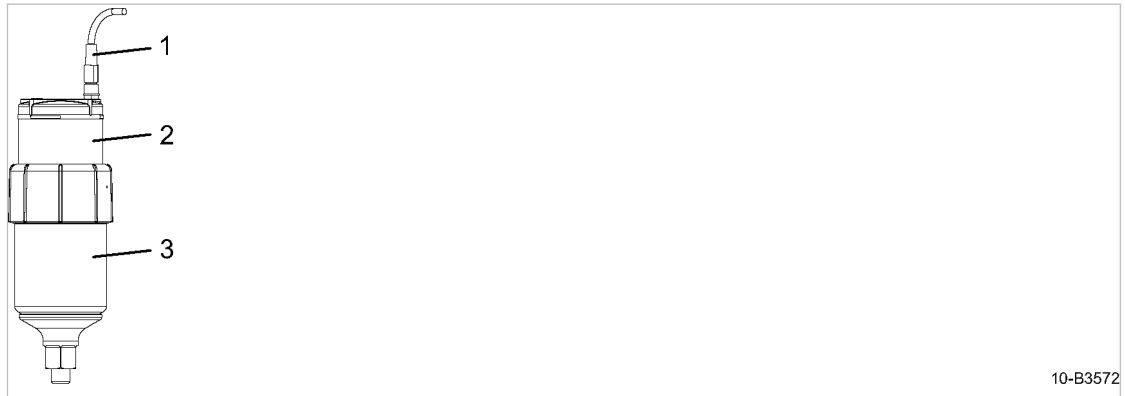

Fig. 32 Grease cartridge fill date

- ① Year
- ② Calendar week

- Check the year ① and calendar week ② of the fill date. Replace any grease cartridges more than 2 years old.



10-B3572

Fig. 33 Changing the grease cartridge

- ① Cable
- ② Actuator
- ③ Grease cartridge

1. Remove the cable ① from the actuator ②.
2. Turning the actuator with the grease cartridge ③ to remove it from the support on the lubricating point.
3. Separate the actuator and grease cartridge by removing the clamping nut.
4. Screw a new grease cartridge and the actuator together.
5. Screw the actuator with the grease cartridge back into the lubrication point.
6. Reconnect the cable to the actuator.

Result The lubrication system is ready to operate. The number of remaining lubrication impulses is reset automatically on the display.



Dispose of used grease cartridges in accordance with applicable environmental regulations

10.11 Checking the coupling

A defective coupling is recognizable by:

- Noisy running
- Surface cracks
- Color change

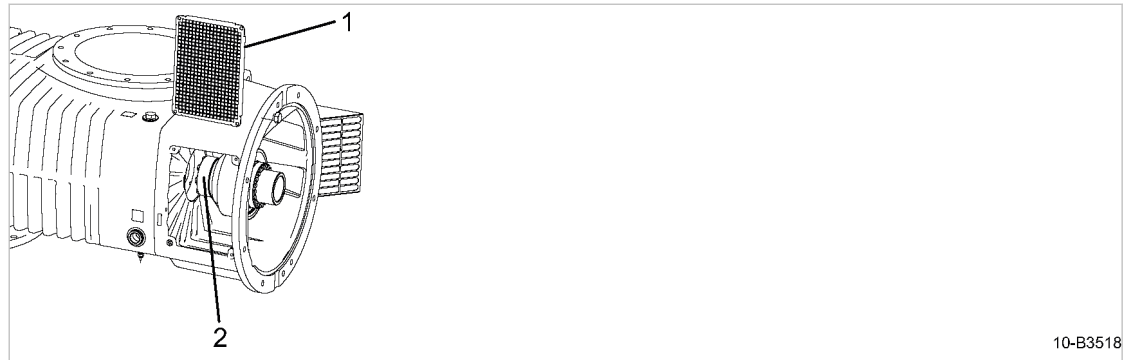

Fig. 34 Checking the coupling

- ① Safety screen
- ② Coupling

10.11.1 Visual inspection for uneven or noisy running

Precondition The drive motor is running.
 The safety screen remains installed.

1. **⚠ WARNING** *Noise from the running machine when the access door of the sound enclosure (Option H12) is opened!
 Hearing may be damaged.*
 - Always wear ear protection.
2. **⚠ WARNING** *Danger of burns from hot components!*
 - Wear long-sleeved clothing and protective gloves.
 - Work with caution.
3. **⚠ WARNING** *Danger of injury from rotating coupling!*
 - Never switch the machine on without the safety screen in place at the side of the coupling.
4. Visually check the coupling for uneven running.



Coupling runs uneven?

- Have the coupling checked by an authorized KAESER service representative.

10.11.2 Visually check for damages

Precondition The power supply disconnecting device is switched off,
 lock out and tag out the device,
 the absence of any voltage has been verified.
 The machine has cooled down.

1. Unscrew the safety screen ①.
2. Turn the coupling ② by hand and check for damage or color change.
3. Refit the safety screen.
4. Close all access doors and reinstall all enclosure panels.



Coupling has cracks or color changes?

- Have a damaged coupling changed by an authorized KAESER service representative.

10.12 Testing the safety relief valve

Free movement of the safety relief valve's tension rod is checked by hand or with a lifting device.

Precondition The machine is switched off.
The machine is fully vented to atmosphere.

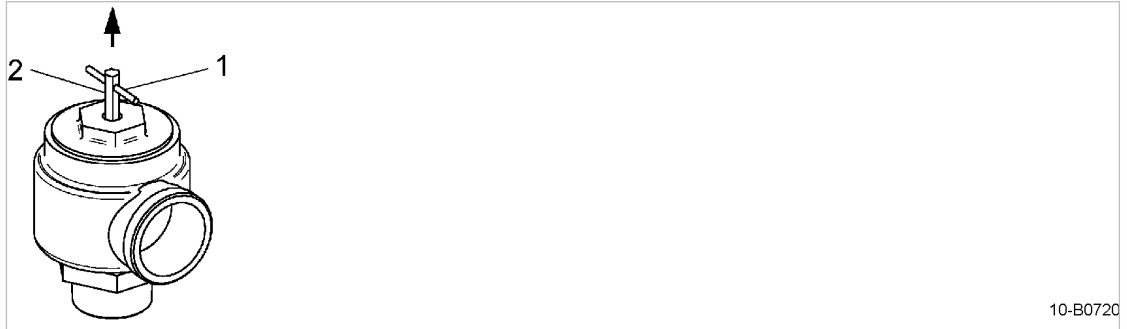

Fig. 35 Testing the safety relief valve

- ① Opening lever
- ② Tension rod

- Check for free movement of the tension rod ② by pulling vertically by the opening lever ①. The valve opens as soon as maximum working pressure is exceeded.
- Never operate the machine without a correctly functioning safety relief valve!
- Do **not** adjust the safety relief valve.
- Immediately replace a defective safety relief valve.

10.13 Testing the EMERGENCY STOP push button

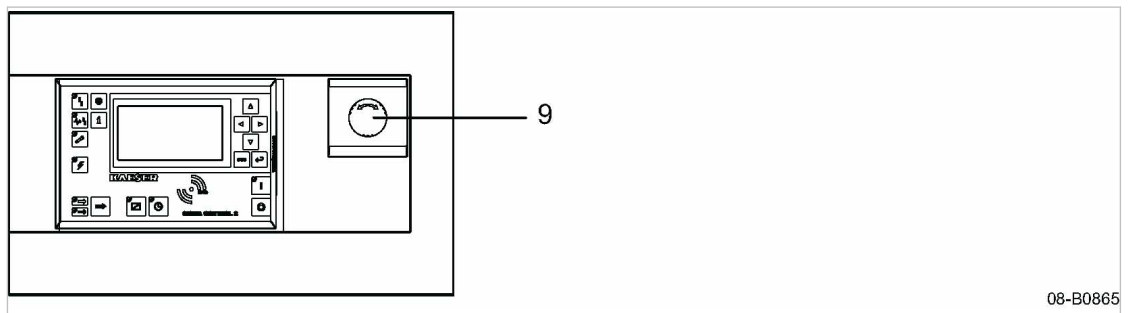

Fig. 36 Testing the EMERGENCY STOP push button

- ⑨ EMERGENCY STOP push button

Precondition The drive motor is running.

1. Press the EMERGENCY STOP push button.

The drive motor stops, the pressure system is vented and the machine is prevented from automatic restarting.



The drive motor does not stop?

The safety function of the EMERGENCY STOP push button is no longer ensured.

- Immediately shut down the machine and contact an authorized KAESER service representative.

2. Turn the EMERGENCY STOP push button in the direction of the arrow to unlatch it.
3. Acknowledge the fault message.

11 Spares, Operating Materials, Service

11.1 Note the nameplate

The nameplate contains all information to identify your machine. This information is essential to us in order to provide you with optimal service.

- Please give the information from the nameplate with every inquiry and order for spares.

11.2 Ordering spare parts and operating fluids/materials

KAESER spare parts and operating fluids/materials are original KAESER products. They are specifically selected for use in KAESER machines.

⚠ WARNING

There is risk of personal injury or damage to the machine resulting from the use of unsuitable spare parts or operating fluids/materials!

Non-Kaeser parts and operating fluids/materials may be unsuitable or of poor quality and can damage the machine or impair its proper function.

Damage to the machine can also result in personal injury.

- *Use only original KAESER parts and operating fluids/materials.*
- *Have an authorized KAESER service representative carry out regular repair and maintenance.*

Machine

Name	Number
Filter mat, control cabinet	1100
Filter mat, cover, control cabinet	1150
Air filter	1250
Lubricating oil	1600
Grease cartridge	1650

Tab. 37 Ordering spare parts and operating fluids/materials

11.3 Spare parts for service and repair

With the help of this parts list you can plan your material requirement according to operating conditions and order the spare parts you need.



- Make sure that any inspection, service (preventive maintenance) or repair tasks not described in this manual are carried out by an authorized KAESER service representative.

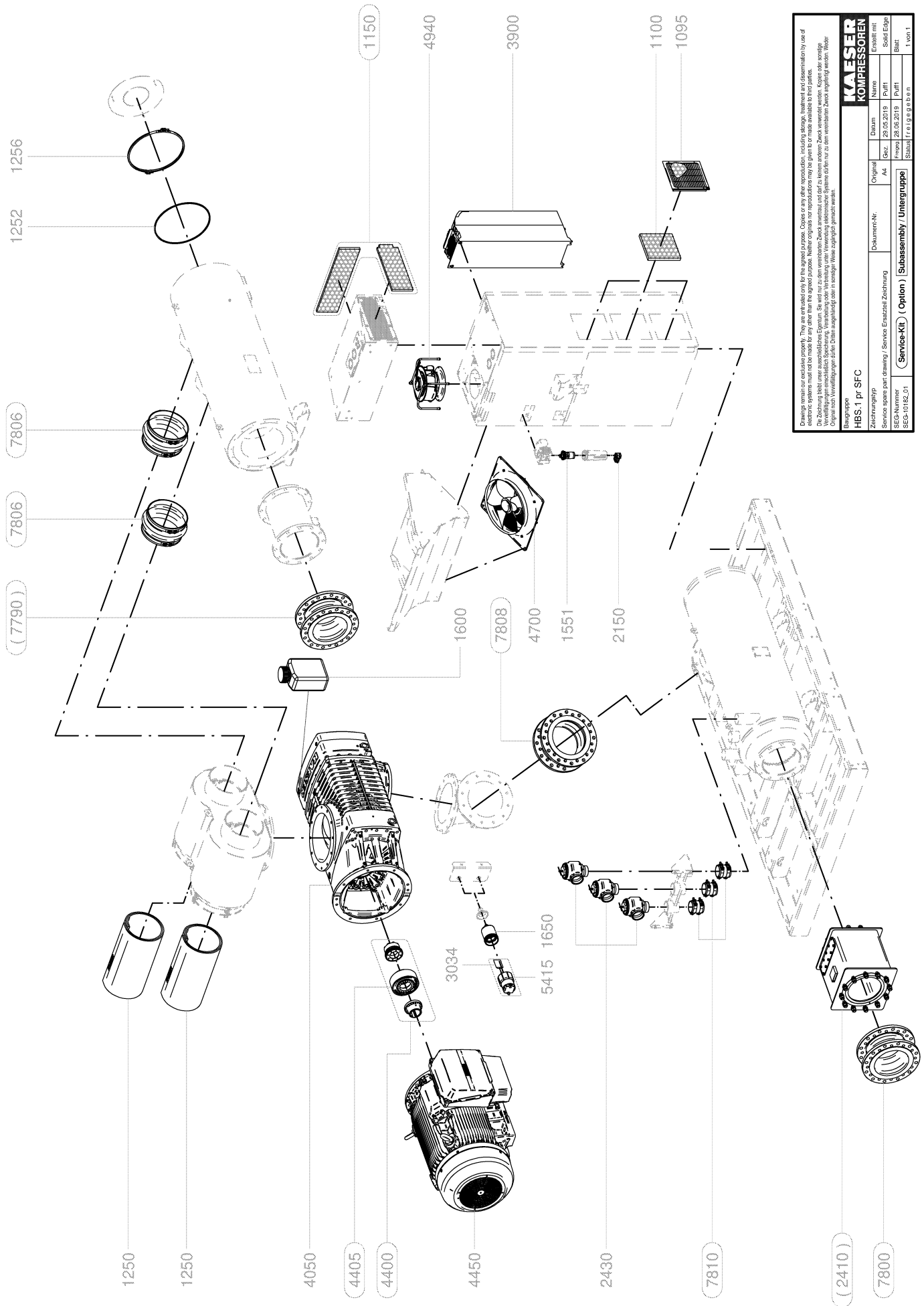

Einzelteil mit Ersatzteil-Nr. This part is not a spare part. Original parts are not available for this part. Die Zeichnung bleibt unter ausschließlicher Eigentum. Sie wird nur zu dem vereinbarten Zweck erstellt und darf zu keinem anderen Zweck verwendet werden. Kopieren oder sonstigen Vervielfältigen, einschließlich Reproduktion, Veränderung oder Verbreitung unter Verwendung elektronischer Systeme dürfen nur zu dem vereinbarten Zweck angefertigt werden. Weder das Original noch Kopien dürfen Dritten zugänglich gemacht werden.

KAESER KOMPRESSOREN		Name	Erstellt mit
Zahnungsgruppe	Dokument-Nr.	Datum	Solid Edge
Service spare part drawing / Service Ersatzteil-Zeichnung	Original	28.05.2013	Perf1
SEGA-Nummer	Alt	28.05.2013	Blatt
SEC-10182_01	(Service-Kit) / Subassembly / Untergruppe	Blatt	1 von 1
Blattgruppe			

Legend		KAESER KOMPRESSOREN
	HBS.1 pr	SEL-4406_01 E
Item	Description	Option
1095	Control cabinet breather	
1100	Filter mat, control cabinet	
1150	Filter mat, converter cabinet	
1250	Air filter insert	
1252	Inlet silencer gasket	
1256	Canopy fastener	
1551	Microfilter element	
1600	SIGMA FLUID	
1650	Motor bearing grease	
2150	Control valve	
2410	Swing check valve	X
2412	Overhaul kit, Swing check valve	X
2430	Pressure limiting valve	
3034	Buffer battery	
3900	Frequency converter	
3476	FC-fan motor	
4050	SIGMA blower block	
4400	Drive coupling	
4405	Coupling element elastic	
4450	Drive motor	
4700	Fan unit	
4940	Control cabinet fan SFC	
5415	Actuator	
7790	Compensator, air inlet	X
7800	Compensator, air outlet	
7806	Intermediate compensator	
7808	Intermediate compensator	
7810	Intermediate compensator	

11.4 KAESER AIR SERVICE

KAESER AIR SERVICE offers:

- authorized KAESER service representatives with KAESER factory training,
- increased operational reliability ensured by preventive maintenance,
- energy savings achieved by avoidance of pressure losses,
- optimum conditions for operation of the compressed air system,
- the security of genuine KAESER spare parts,
- increased legal certainty as all regulations are kept to.

➤ Why not sign a KAESER AIR SERVICE maintenance agreement!

Result Your advantage:
lower costs and higher compressed air availability.

11.5 Completing the contamination declaration

Every company (user) is responsible for the health and safety of its employees. This extends to personnel who carry out servicing work at the user or service contractor.

A Declaration of Contamination must be completed and signed whenever maintenance or repair work is to be carried out on the machine.

1. Contact KAESER SERVICE and request the contamination declaration form.
2. Attach a copy of the Declaration of Contamination to the **outside** of the packing.

12 Decommissioning, Storage and Transport

12.1 Decommissioning

Decommissioning is necessary, for example, under the following circumstances:

- The machine is temporarily not needed,
- The machine is to be moved to another location,
- The machine is to be scrapped.

Temporary decommissioning

Precondition The machine can be started at regular intervals.

- Run the machine once a week for at least 30 minutes at operating temperature to ensure corrosion protection.

Long-term decommissioning

Precondition The power supply disconnecting device is switched off, the device is locked off, the absence of any voltage has been verified.
The machine is fully vented (depressurized).

1. Allow the machine to completely cool down.
2. Disconnect all air and electrical connections.
3. Spray the machine inside and out with a preservative to prevent corrosion.
4. Store the machine in a dry, frost-proof room.

Further information Details of preservatives are found in chapter 12.4.

12.2 Packing

A wooden crate is required for overland transport to protect the machine from mechanical damage. Other measures must be taken for the transport of machines by sea or air. Please contact an authorized KAESER SERVICE for more information.

Material Protective plastic sheeting
Wooden transport crate

Precondition The machine is decommissioned.
The machine is dry and cooled down.

1. Wrap the machine fully in plastic sheeting.
2. Protect the machine in a wooden crate against mechanical damages.

12.3 Transport

12.3.1 Safety

Mass and center of gravity determine the most suitable method of transportation. Both are specified in the dimensional drawing in chapter 13.2.

Precondition Transport only by pallet truck, forklift truck or lifting gear by personnel trained in the safe transportation of loads.

- Ensure the danger area is clear of personnel.

12.3.2 Transport machine with a pallet truck or forklift truck

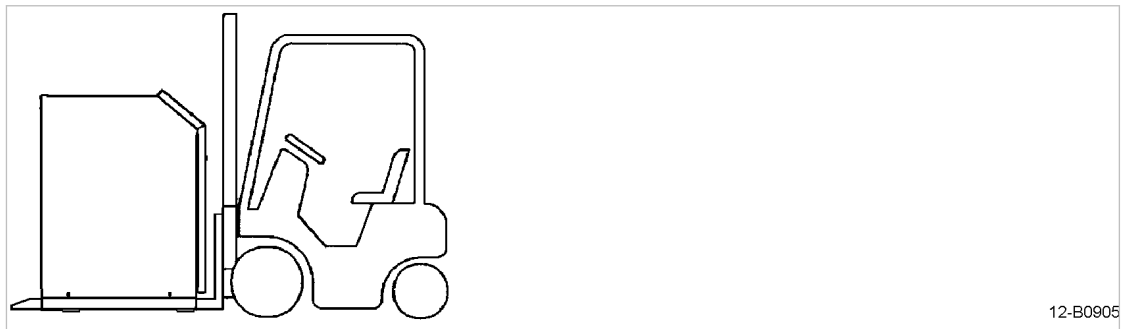

Fig. 37 Transport

1. Take note of the center of gravity.
2. Drive the pallet truck (or forklift truck) fully beneath the entire machine and transport with care.

12.4 Storage

Moisture can lead to corrosion, particularly on the surfaces of the blower airend. The storage temperature must not fall below 5 °F.



Should you have any questions concerning the correct storage and recommissioning procedure, KAESER will be glad to assist you.

CAUTION

*Moving rotors!
Danger of crushing or severing limbs.*

- *Do not reach into the blower airend.*

NOTICE

Moisture and frost can damage the machine.

- *Prevent the ingress of moisture and formation of condensation.*
- Store the machine in a dry, frost-proof room.
- Seal off the inlet and discharge ports to prevent the ingress of dirt.
- Every month, manually turn the motor shaft by approx. 30°.
- Change the lubricating oil annually.

After lengthy storage

- Remove the preservative from the flow chamber with cleaning solvent.
- Observe the procedures for assembly and initial start-up.

12.5 Disposal

When disposing of a machine, drain out all liquids and remove old filters.

Precondition The machine is decommissioned.

1. Completely drain the oil from the machine.
2. Remove old filters.
3. Hand the machine over to an authorized disposal expert.



- Components contaminated with oil must be disposed of in accordance with local environmental protection regulations.

12.5.1 Battery disposal in accordance with local environmental regulations

Batteries contain substances that are harmful to living beings and the environment. For this reason, batteries must not be disposed of with unsorted municipal waste. They must be delivered to the national battery collection system. This procedure facilitates the handling and recycling of batteries. A battery is located in each of the actuators of the automatic lubrication system.

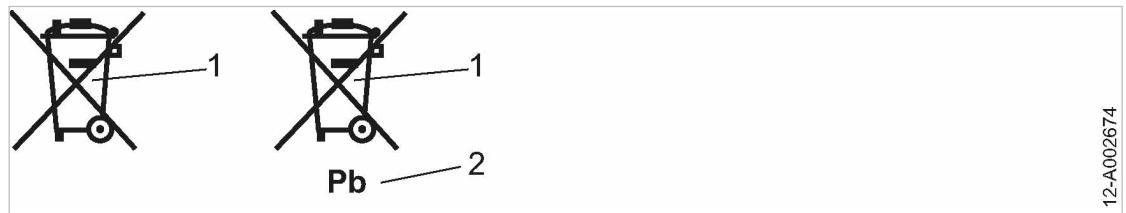

Fig. 38 Battery labelling

- ① Do not dispose of batteries with household waste
- ② Battery contains lead (if applicable)

- Comply with national disposal regulations and dispose of batteries in accordance with local environmental regulations.



- You actively contribute to the protection of our environment when you take used batteries to the appropriate recycling system.

13 Annex

13.1 Pipeline and instrument flow diagram (P+I diagram)

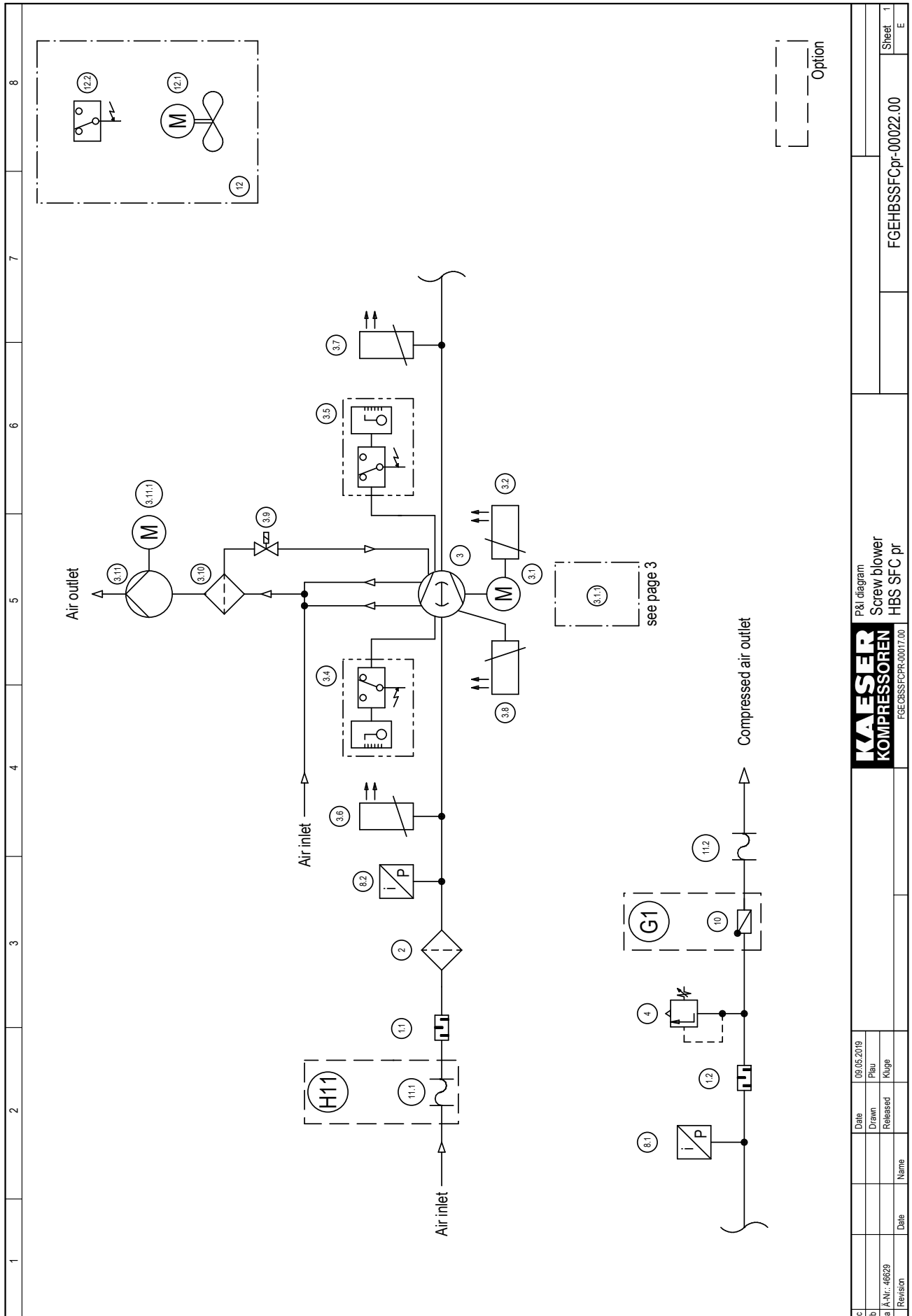

		1	2	3	4	5	6	7	8
1.1	Silencer								
1.2	Silencer								
2	Air filter								
3	Blower block								
3.1	Drive motor								
3.1.1	Automatic lubrication system								
3.2	Pt100 temperature sensor - Drive motor [tM]								
3.4	Oil level monitoring - Drive-end								
3.5	Oil level monitoring - Control-end								
3.6	Pt100 temperature sensor - Inlet temperature [t1]								
3.7	Pt100 temperature sensor - Aired discharge temperature [t2]								
3.8	Pt100 temperature sensor - Oil temperature [t3]								
3.9	Solenoid valve								
3.10	Filter								
3.11	Pump								
3.11.1	Drive motor								
4	Safety relief valve								
8.1	Pressure transducer								
8.2	Pressure transducer								
10	Non-return flap								
11.1	Compensator								
11.2	Compensator								
12	Sound enclosure								
12.1	Fan motor								
12.2	Thermostat - Sound enclosure temperature [tS]								
	Option								
G1	Non-return flap								
H11	Intake from pipeline								

c	Date	09.05.2019	P&I diagram Screw blower HBS SFC pr		FGEHBSFCpr-00022.00	Sheet 2 E
b	Drawn	Plau				
a	Released	Kluge				
Revision	Date	Name				

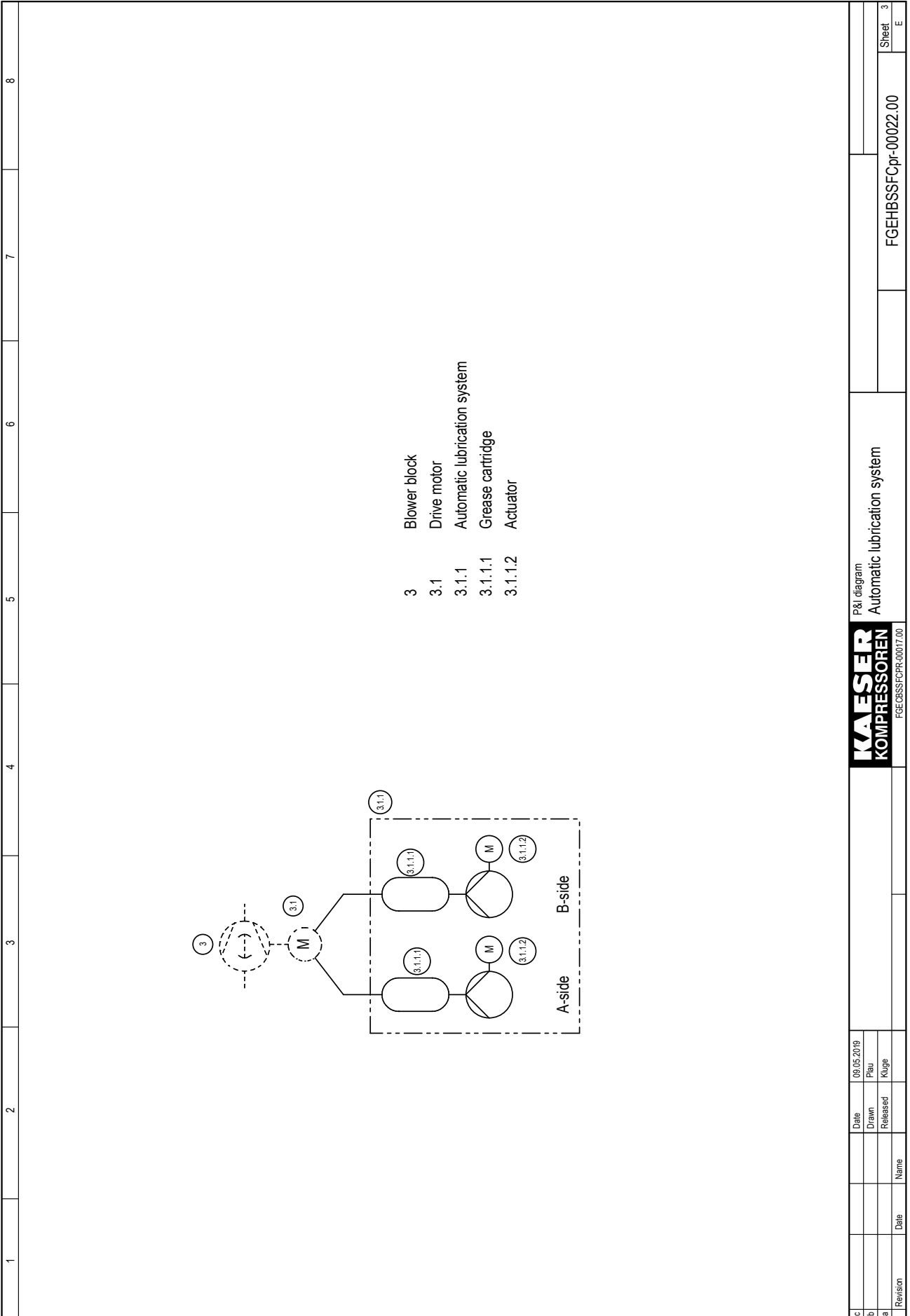

c	Date	09.05.2019	Plau
b	Drawn		Kluge
a	Released		
Revision	Date	Name	

KAESER
KOMPRESSOREN

FGEHBSSFCPR-00017.00

P&I diagram
Automatic lubrication system

FGEHBSSFCpr-00022.00

Sheet: 3
E

13.2 Dimensional drawing

Foundation plan

For floor mounting:
2x Ø 5/8
8x Ø 5 7/8

Center of gravity
Position marginally dependent
on design

Type	SFC			Weight**
	Nominal power	X*	Y*	
HBS 1600	175 hp	46 1/16	59 13/16	~ 12754 lb
	200 hp	48 1/4	41 9/16	~ 12952 lb
	250 hp	46 7/16	60 5/8	~ 13095 lb

(approximate dimensions)
** Nominal value; Actual value depends on design

Dimensions shown in inches

A 1:20
Z 1:10

Flange connection
ANSI 12"
B 16.5-1981
150 lb./sq.in.
HBS1600 M
HBS1600 L

ANSI 12"
B 16.5-1981
150 lb./sq.in.
HBS1600 M
HBS1600 L

Inlet: intake air
Inlet: cooling air
Outlet: exhaust air
Outlet: cooling air

2xØ 3
5xØ 13/16
Cable bushing

C52

M16

min.

Change number
Projection
Document TZN1
10441876 USE 00
Document TZD
10441876 D 00
Status
Released

Scale
1:40
Original
A3
Designation
HBS.1 SFC pr
Dimension and connection dim.

Date
Drawn 25.07.2019
BOGISCHE2
Edited 03.03.2020
BOGISCHE2
Released 03.03.2020
KLUGE1

Name
BOGISCHE2
KLUGE1

Language
USE

Sheet
1 / 1

13.3 Noise emission

The values for sound pressure levels and sound power levels are provided in the table below.

If the texts of the tables are not provided in the chosen language, a translation can be found here:

	Table legend
a)	Model
b)	Pressure differential
c)	Sound pressure level
d)	Sound power level

Tab. 38 Noise emission

a)	b) Pressure differential		c) Sound pressure level	d) Sound power level
	[mbar]	[psi]	[dB(A)]	[dB(A)]
			± 3 dB(A)	± 3 dB(A)
HBS 254 L	300	4	78	97
HBS 254 L	400	6	76	95
HBS 254 L	500	7	75	94
HBS 254 L	600	9	75	94
HBS 254 L	650	9	75	94
HBS 254 M	450	7	79	98
HBS 254 M	500	7	79	98
HBS 254 M	600	9	79	98
HBS 254 M	700	10	78	97
HBS 254 M	800	12	78	97
HBS 254 M	900	13	76	95
HBS 254 M	1000	15	75	94
HBS 254 M	1100	16	75	94

13.4 Electrical diagram

1	2	3	4	5	6	7	8
<p>Wiring Diagram</p> <p>Blower with frequency converter</p> <p>Siemens Sinamics G120 PM240-2 + Sigma Control 2 (SC2)</p> <p>HBS.1: 175hp-335hp (132kW - 250kW)</p> <p>380V +10/-5% 3ph 60Hz 460V ±10% 3ph 60Hz</p> <p>Power supply: WYE system with center point solidly grounded</p>							
<p>manufacturer: KAESER KOMPRESSOREN SE</p> <p>Postfach 2143 96410 Coburg</p>							
<p>ATTENTION !!!</p> <p>The document gives collective information on power supply voltages and frequencies for all machines. The voltage and frequency and local conditions under which any particular machine may be used are given on the nameplate of the machine and in the accompanying service manual.</p>							
<p>The drawings remain our exclusive property. They are entrusted only for the agreed purpose. Copies or any other reproductions, including storage, treatment and dissemination by use of electronic systems must not be made for any other than the agreed purpose. Neither originals nor reproductions must be forwarded or otherwise made accessible to third parties.</p>							
<p>KAESER KOMPRESSOREN <small>SXB OF C-03010.02</small></p>		<p>cover page Blower xFC+SC2</p>		<p>=</p>		<p>+</p>	
<p>c</p>		<p>Date 21.09.2020</p>		<p>USE</p>		<p>page 1</p>	
<p>b</p>		<p>Drawn M.Zeesh</p>		<p></p>		<p></p>	
<p>a</p>		<p>Released M.Zeesh</p>		<p></p>		<p></p>	
<p>A. Change</p>		<p>Date</p>		<p>Name</p>		<p>DXB.XFC-U3040.02</p>	
						<p>1 Sht.</p>	

Lfd. Nr. No.	Benennung Name	Zeichnungsnummer (Kunde) Drawing No. (customer)	Zeichnungsnummer (Hersteller) Drawing No. (manufacturer)	Blatt Page	Anlagenkennzeichen Unit designation
1	cover page		DXB.XFC-U3040.02	1	
2	list of contents		ZXB.XFC-U3040.02	1	
3	general instructions	instructions + option	UXB.XFC-U3040.02	1	
4	component legend	component legend	UXB.XFC-U3040.02	2	
5	electrical component parts list	Common parts	UXB.XFC-U3040.02	3	
6	electrical component parts list	Common parts	UXB.XFC-U3040.02	4	
7	electrical component parts list	performance-related components	UXB.XFC-U3040.02	5	
8	wiring diagram	power unit	SXB.XFC-U3040.02	1	
9	wiring diagram	control + vent	SXB.XFC-U3040.02	2	
10	wiring diagram	control voltage	SXB.XFC-U3040.02	3	
11	wiring diagram	controller ventilator + control	SXB.XFC-U3040.02	4	
12	wiring diagram	vacuum pump + SC2 + IOM	SXB.XFC-U3040.02	5	
13	wiring diagram	IOM-configuration	SXB.XFC-U3040.02	6	
14	wiring diagram	digital inputs IOM	SXB.XFC-U3040.02	7	
15	wiring diagram	analog inputs IOM	SXB.XFC-U3040.02	8	
16	wiring diagram	Relay-outputs IOM	SXB.XFC-U3040.02	9	
17	wiring diagram	frequency converter	SXB.XFC-U3040.02	10	
18	wiring diagram	Handling terminals	SXB.XFC-U3040.02	11	
19	wiring diagram	Feed line connection top	SXB.XFC-U3040.02	12	
20	wiring diagram	Feed line connection bottom	SXB.XFC-U3040.02	13	
21	terminal connection	-X0,-X11,-X12,-X13,-X14	KXB.XFC-U3040.02	1	
22	terminal connection	-X15,-X16,-X21,-X22,-X100	KXB.XFC-U3040.02	2	
23	lay-out	control panel DBS SFC	AXB.XFC-U3040.02	1	

Date		21.09.2020	list of contents	=	+	ZXB.XFC-U3040.02	page	1
c	Drawn	M.Zeesh						
b	Released	M.Zeesh						
a	Date	Name						
B	Change							

1	2	3	4	5	6	7	8
<p>general instructions</p> <p>ATTENTION !!! Install supplies, grounding and shock protection to local safety regulations. Do not make or break live plug-in connectors.</p>							
<p>control cabinet wiring for non-designated conductors with multi-standard stranded conductors primary circuits: control voltage AC 24/230V: control voltage AC 24/230V grounded: control voltage DC 24V(+): control voltage DC 24V(-) grounded: external voltage: ground conductor:</p>							
<p>black 2,5mm² H07V-K, 14AWG UL-Style 1015, CSA-TEW red 1mm² H05V-K, 18AWG UL-Style 1015, CSA-TEW white 1mm² H05V-K, 18AWG UL-Style 1015, CSA-TEW blue 1mm² H05V-K, 18AWG UL-Style 1015, CSA-TEW blue/white 1mm² H05V-K, 18AWG UL-Style 1015, CSA-TEW orange 1,5mm² H07V-K, 16AWG UL-Style 1015, CSA-TEW green/yellow H07V-K, UL-Style 1015, CSA-TEW</p>							
<p>-----</p> <p>type model-dependent components</p> <p>B13 = mode of operation overpressure B14 = mode of operation Vacuum</p>							
<p style="text-align: right;">KAESER KOMPRESSOREN</p>							
<p>general instructions Blower xFC+SC2 instructions + option</p>							
<p>UXB.XFC-U3040.02</p>							
<p>page 1 5 Sht.</p>							

		1	2	3	4	5	6	7	8		
	-B1/-B4 -B5 -B24 -B40/-B43 -B55 -B60 -B70 -B80/-B81	pressure transducer (4...20mA) differential pressure switch filter clogging overload Relay vent motor temperature probe Blower (PT100) PT100 oil temperature monitoring PT100 blower motor thermostat soundproofing casing oil level switch									
	-F1 -2FU -3FU -4FU -8FU -10FU -29FU -F86	circuit breaker control voltage tapping primary control fuse control transformer secondary control fuse control transformer fuse ventilator soundproofing casing fuse controller ventilator fuse 24V-AC fuse phase sequence relay Surge protective device (Canada only)									
	-K10 -K20 -K21 -K29 -K50 -K51 -K55 -K56+57+58+59 -K60	solenoid valve Oil return SIGMA CONTROL 2 (SC2) (MCS) SIGMA CONTROL 2 (SC2) (IOM-Modul) phase sequence relay coupling relay controller ventilator coupling relay ventilator soundproofing casing control relay Oil return coupling relay Lubrication system -M1 contactor EMERGENCY STOP (external/customer)									
	-M1 -M4 -M8 -M10 -M28, -M29 -Q8	blower motor ventilator soundproofing casing controller ventilator vacuum pump Gear housing ventilation Lubrication system -M1 (automatic) contactor controller ventilator									
	-R3.2	Tape-wound core									
	-S1 -S9	EMERGENCY STOP pushbutton REMOTE reset fault message									
	-T1 -T11 -T21 -T45 -X0 -X11 -X12 -X15 -X16 -X21 -X22 -X100 -Kz0 -X1 -X2 -X3 -X4 -X5 -X6 -K21 -X1 -X2 -X3 -X4 -X5, -X9 -X6 -X7 -X8 -X11...-X13 -X14...-X17 -X18...-X29 -X30...-X32	frequency converter control transformer 24+115V-AC control voltage supply 24V-DC isolating amplifier terminal strip, power supply terminal strip, control SC2-IOM digital outputs SC2-IOM digital inputs frequency converter analog signals control voltage 24V-DC frequency converter 24V-DC EMERGENCY STOP (external/customer) <i>Main Control System SC2 MCS</i> Ethernet IO-BUS RS485-FC (USS-Bus) communication module SD card slot ground connection <i>IO-Modul SC2 IOM-1</i> <i>inside</i> <i>IO-Bus input</i> <i>IO-Bus output</i> digital inputs power supply unit and Transistor outputs Relay outputs analog input 0-20mA analog input PT100 digital inputs <i>external</i> analog inputs 0-20mA analog inputs PT100 digital inputs digital outputs									
									= +		
									UXB.XFC-U3040.02		
									page 2 5 Sht.		
				KAESER KOMPRESSOREN				component legend Blower xFC+SC2 component legend			
c		Date	21.09.2020								
b		Drawn	M.Zeeth								
a		Released	M.Zeeth								
C		Change	Date	Name							

model	Common parts		=	+	UXB.XFC-U3040.02	page 3	5 Sht.
	380 V	460 V					
machine power supply	380 V + 10/-5 % 60 Hz	460 V ±10 %, 60 Hz					
pressure transducer -B1 Huba Control	894786.0 0.-1200mbar	894786.0 0.-1200mbar					
pressure transducer -B4 Huba Control	894787.0 0.1200mbar	894787.0 0.1200mbar					
differential pressure switch -B5 Dungs	893307.0 setting: 35mbar	893307.0 setting: 35mbar					
temperature probe -B40/-B43 Sika	895615.00010 Pt100	895615.00010 Pt100					
oil temperature (C39) -B55 Wika	895603.00100 Pt100	895603.00100 Pt100					
thermostat soundproofing casing -B70 Jumo	894861.11000 heatTHERM-R-2 30-80°C setting: 60°C	894861.11000 heatTHERM-R-2 30-80°C setting: 60°C					
oil level switch -B80/-B81 Elobau	894631.0	894631.0					
circuit breaker -F1 Siemens	7.8237.00240 3RV2711-1GD10 6,3 A	7.8237.00240 3RV2711-1GD10 6,3 A					
attachment piece Busbar system -Wöhner	7.3173.01270 25A 4 mm² / 32430	7.3173.01270 25A 4 mm² / 32430					
fuse -2FU Gould	(2x) - 7.3317.1 ATQR 3 A - 600 V - class CC	(2x) - 7.3317.1 ATQR 3 A - 600 V - class CC					
fuse -3FU Gould	(1x) - 7.3161.00160 ATQR 5 A - 600 V - class CC	(1x) - 7.3161.00160 ATQR 5 A - 600 V - class CC					
fuse -4FU Gould	(3x) - 7.3161.00360 ATDR 1 A - 600 V - class CC	(3x) - 7.3161.00360 ATDR 1 A - 600 V - class CC					
fuse -8FU Gould	(1x) - 7.3161.00350 ATDR 3 A - 600 V - class CC	(1x) - 7.3161.00350 ATDR 3 A - 600 V - class CC					
fuse -10FU	893936.0 5x20 0,315 A-T 250 VAC	893936.0 5x20 0,315 A-T 250 VAC					
fuse -29FU Gould	(3x) - 7.3161.00360 ATDR 1 A - 600 V - class CC	(3x) - 7.3161.00360 ATDR 1 A - 600 V - class CC					
fuse socket -2FU -3FU -4FU -8FU -29FU Wöhner	2-pole - 7.3320.00070 1-pole - 7.3320.00050 3-pole - 7.3320.00060 1-pole - 7.3320.00050 3-pole - 7.3320.00060 class CC - Ambus Easy Switch	2-pole - 7.3320.00070 1-pole - 7.3320.00050 3-pole - 7.3320.00060 1-pole - 7.3320.00050 3-pole - 7.3320.00060 class CC - Ambus Easy Switch					
solenoid valve -K10 bükert	895601.0 24V-DC 8W	895601.0 24V-DC 8W					
Blower control -K20 Prodrive	7.7601.0 SC2MCS	7.7601.0 SC2MCS				21.09.2020	M.Zeesh
Blower control -K21 Prodrive	7.7602.1 SC2IOM-1	7.7602.1 SC2IOM-1					M.Zeesh
phase sequence relay -K29 Siemens	7.7830.00600 3UG4615	7.7830.00600 3UG4615					
coupling relay -K50 Wieland	7.3149.02100 24DC-2W-250V6A	7.3149.02100 24DC-2W-250V6A					
Fortsetzung: nächstes Blatt							

 electrical component parts list
 Blower xFC+SC2
 Common parts

**KAESER
KOMPRESSOREN**

 Date
 Drawn
 Released

 Name
 Date

C Change

model	Common parts			
	380 V	460 V		
machine power supply	380 V + 10/-5 % 60 Hz	460 V ±10 %, 60 Hz		
coupling relay -K51/56/57/58/59 Wieland	7.3149.00660 24DC-1W-250V6A	7.3149.00660 24DC-1W-250V6A		
coupling relay -K55 Siemens	7.8237.00340 3RH2122-2JB40 DC 17-30 V AC-15: 240 V/10 A	7.8237.00340 3RH2122-2JB40 DC 17-30 V AC-15: 240 V/10 A		
vent motor soundproofing casing -M4 ebm	895735.0 W3G450-DL07-M4 380 V-Y/60 Hz 530W - 0,85 A	895735.0 W3G450-DL07-M4 460 V-Y / 60 Hz 550W - 0,75 A		
vent motor control cabinet -M8 ebm	895744.0 K3G280-RB52-17 115 V-AC / 60 Hz 165W - 2,3 A	895744.0 K3G280-RB52-17 115 V-AC / 60 Hz 165W - 2,3 A		
vacuum pump -M10 Schwarzer	895612.00100 24V-AC 60 Hz, 4W	895612.00100 24V-AC 60 Hz, 4W		
Nachschmierung -M1 -M28/-M29 perma-tec	895752.0 perma STAR CONTROL 24 V-DC 1,2W	895752.0 perma STAR CONTROL 24 V-DC 1,2W		
contactor -Q8 Siemens	7.8740.00310 3RT2016-1AK61	7.8740.00310 3RT2016-1AK61		
auxiliary switch -Q8 Siemens	7.8237.03040 3RH2911-2FA40	7.8237.03040 3RH2911-2FA40		
interference suppressor - Siemens	7.8740.05130 3RT2916-1CC00	7.8740.05130 3RT2916-1CC00		
EMERGENCY STOP pushbutton -S1	834424.01000 subassembly complete	834424.01000 subassembly complete		
control transformer -T11 Block	7.2238.10090 USTE630 - 630 VA 208-600 V/2x 115 V+ 24 V	7.2238.10090 USTE630 - 630 VA 208-600 V/2x 115 V+ 24 V		
power supply -T21 Prodrive	7.7605P0 PSDC24/2.5 100-240 V-AC/24 V-DC 2,5 A	7.7605P0 PSDC24/2.5 100-240 V-AC/24 V-DC 2,5 A		
isolating amplifier -T45 Phoenix	7.2892.00040 MCR-C-III-00-DC	7.2892.00040 MCR-C-III-00-DC		
control line terminal -X. 11/12/15/16/21/22/100 Handling	895635.0 Wieland WTP fig. 1, Sht. 11	895635.0 Wieland WTP fig. 1, Sht. 11		

		page 4	
		5 Sht.	
		UXB.XFC-U3040.02	
		electrical component parts list	
		Blower xFC+SC2	
		Common parts	
		KAESER KOMPRESSOREN	
c	Date	21.09.2020	
b	Drawn	M.Zeeh	
a	Released	M.Zeeh	
C	Change		
	Date		
	Name		

model	performance-related components				page 5 5 Sht.
	175 hp HBS (132 kW)	200 hp HBS 160 kW	270 hp HBS (200 kW)	335 hp HBS (250 kW)	
machine power supply	380 V + 10/-5% 60 Hz	380 V + 10/-5% 60 Hz	380 V + 10/-5% 60 Hz	380 V + 10/-5% 60 Hz	= + UXB.XFC-U3040.02
machine power supply	460 V ±10% 60 Hz	460 V ±10% 60 Hz	460 V ±10% 60 Hz	460 V ±10% 60 Hz	
Surge protective device	-F86 Dehn 7.8669.00020 DG MU 3PY 480 3W+ G	7.8669.00020 DG MU 3PY 480 3W+ G	7.8669.00020 DG MU 3PY 480 3W+ G	7.8669.00020 DG MU 3PY 480 3W+ G	electrical component parts list performance-related components KAESER KOMPRESSOREN
Blower motor	-M1 Siemens 895631.0 440V-D / 60 Hz 230 A / 3587rpm	895632.0 440V-D / 54 Hz 280 A / 3223rpm	895633.0 440V-D / 66 Hz 345 A / 3943rpm	895634.0 440V-D / 67,5 Hz 395 A / 4040rpm	
line commutation reactor	-R1 Siemens integrated (intern -T1) ---	integrated (intern -T1) ---	integrated (intern -T1) ---	integrated (intern -T1) ---	
Tape-wound core	-R3.0 -R3.1 -R3.2 Magnetec 7.8538.00050 (M115)	7.8538.00050 (M115)	7.8538.00050 (M115)	7.8538.00050 (M115)	
interference suppression filter	-R11 integrated (intern -T1) ---	integrated (intern -T1) ---	integrated (intern -T1) ---	integrated (intern -T1) ---	
frequency converter	-T1 7.8833.01210 6SL3210-1PE32-5AL0	7.8833.01220 6SL3210-1PE33-0AL0	7.8833.01230 6SL3210-1PE33-7AL0	7.8833.01240 6SL3210-1PE34-8AL0	
control unit	7.7830.00710 6SL3244-0BB12-1BAx	7.7830.00710 6SL3244-0BB12-1BAx	7.7830.00710 6SL3244-0BB12-1BAx	7.7830.00710 6SL3244-0BB12-1BAx	
instrument panel	Siemens ---	---	---	---	
motor cable	-W211 (GRD) 2x 3x 3/0 AWG (95 mm ²) 2x 2/0 AWG (70 mm ²) 600 V - 90°C	2x 3x 4/0 AWG (120 mm ²) 2x 2/0 AWG (70 mm ²) 600 V - 90°C	2x 3x 300MCM (150 mm ²) 2x 3/0 AWG (95 mm ²) 600 V - 90°C	2x 3x 300MCM (150 mm ²) 2x 3/0 AWG (95 mm ²) 600 V - 90°C	
connection Insulated supple bar	-W280 4x 300MCM (150 mm ²)	4x 10 x 24 x 1 (240 mm ²)	4x 10 x 24 x 1 (240 mm ²)	4x 10 x 24 x 1 (240 mm ²)	
supply terminals	-X0: U1/V1/W1 Torque Stripped length X 7.3173.00980 Wöhner 01537 2x 3/0 AWG-600MCM (2x 95-300 mm ²) 266lb in (30Nm) 45 mm	7.3173.00980 Wöhner 01537 2x 3/0 AWG-600MCM (2x 95-300 mm ²) 266lb in (30Nm) 45 mm	7.3173.00980 Wöhner 01537 2x 3/0 AWG-600MCM (2x 95-300 mm ²) 266lb in (30Nm) 45 mm	7.3173.00980 Wöhner 01537 2x 3/0 AWG-600MCM (2x 95-300 mm ²) 266lb in (30Nm) 45 mm	
supply terminals	-X0: GRD Torque Stripped length X 7.8952.00030 IHI S500-41-63 2x 4 AWG-500MCM (2x 25-300 mm ²) 500lb in (56Nm) 35 mm fig. 1, Sht. 12/13	7.8952.00030 IHI S500-41-63 2x 4 AWG-500MCM (2x 25-300 mm ²) 500lb in (56Nm) 35 mm fig. 1, Sht. 12/13	7.8952.00030 IHI S500-41-63 2x 4 AWG-500MCM (2x 25-300 mm ²) 500lb in (56Nm) 35 mm fig. 1, Sht. 12/13	7.8952.00030 IHI S500-41-63 2x 4 AWG-500MCM (2x 25-300 mm ²) 500lb in (56Nm) 35 mm fig. 1, Sht. 12/13	
supply	fig. 1, Sht. 12/13	fig. 1, Sht. 12/13	fig. 1, Sht. 12/13	fig. 1, Sht. 12/13	

c	Date	21.09.2020
b	Drawn	M.Zeesh
a	Released	M.Zeesh
C Change	Name	
	Date	

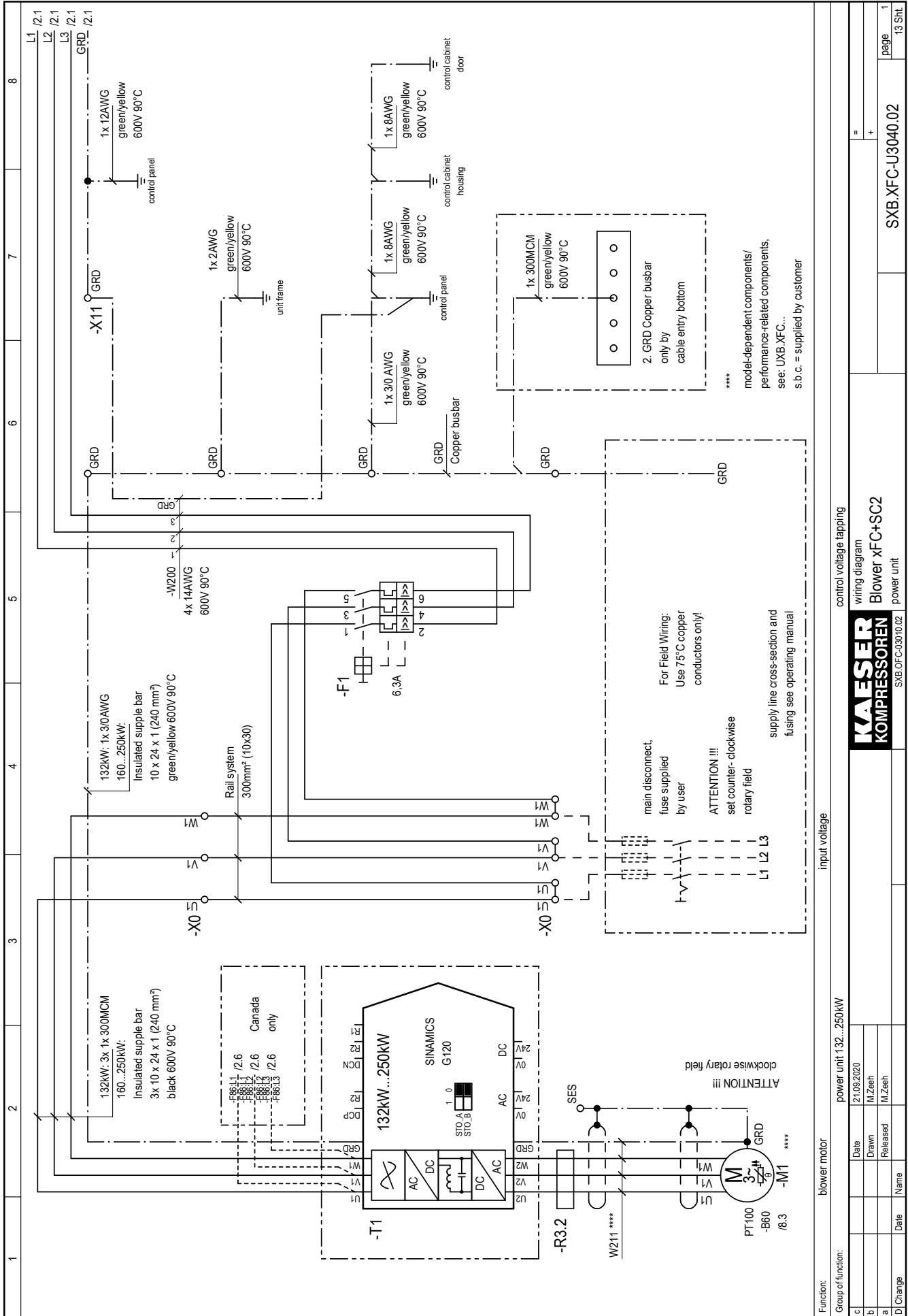

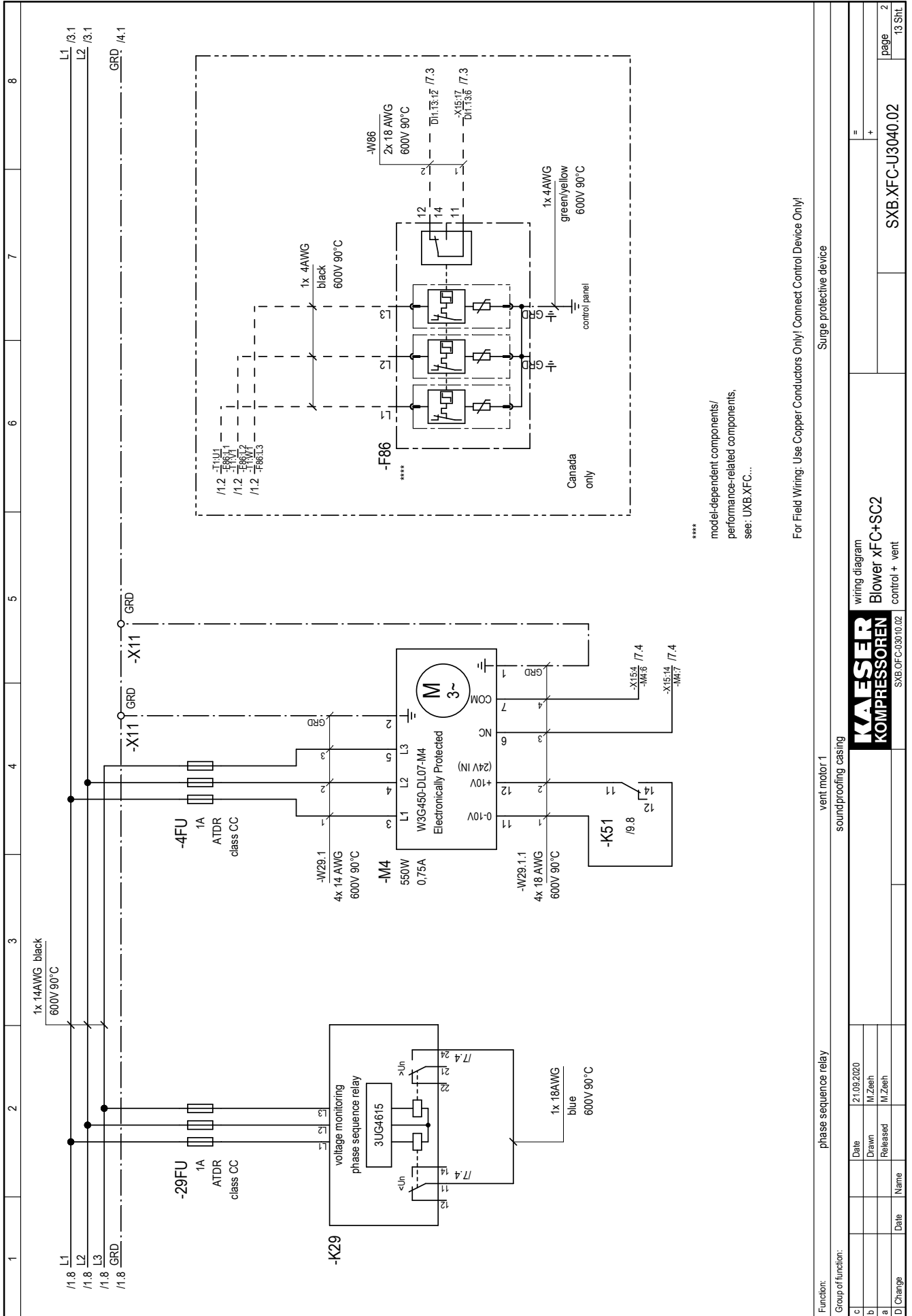

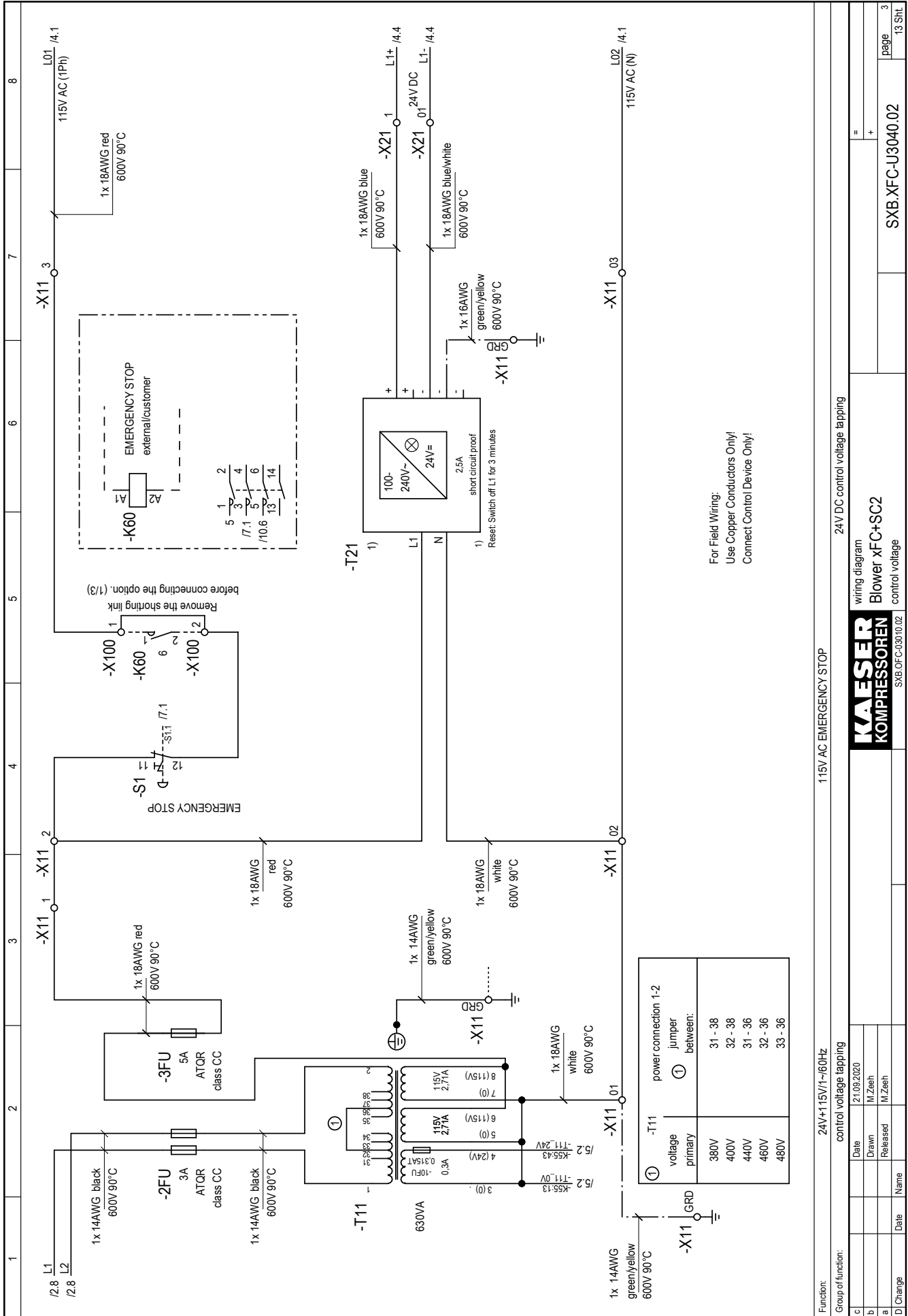

Function:		24V+115V/1~60Hz	
Group of function:		control voltage tapping	
c	Date	21.09.2020	
b	Drawn	M.Zeeh	
a	Released	M.Zeeh	
D	Change	Date	Name
wiring diagram		Blower xFC+SC2	
control voltage		control voltage	
24V DC control voltage tapping		115V AC EMERGENCY STOP	
=		+	
SX.B.XFC-U3040.02		SX.B.XFC-U3040.02	
page		13 Sht	

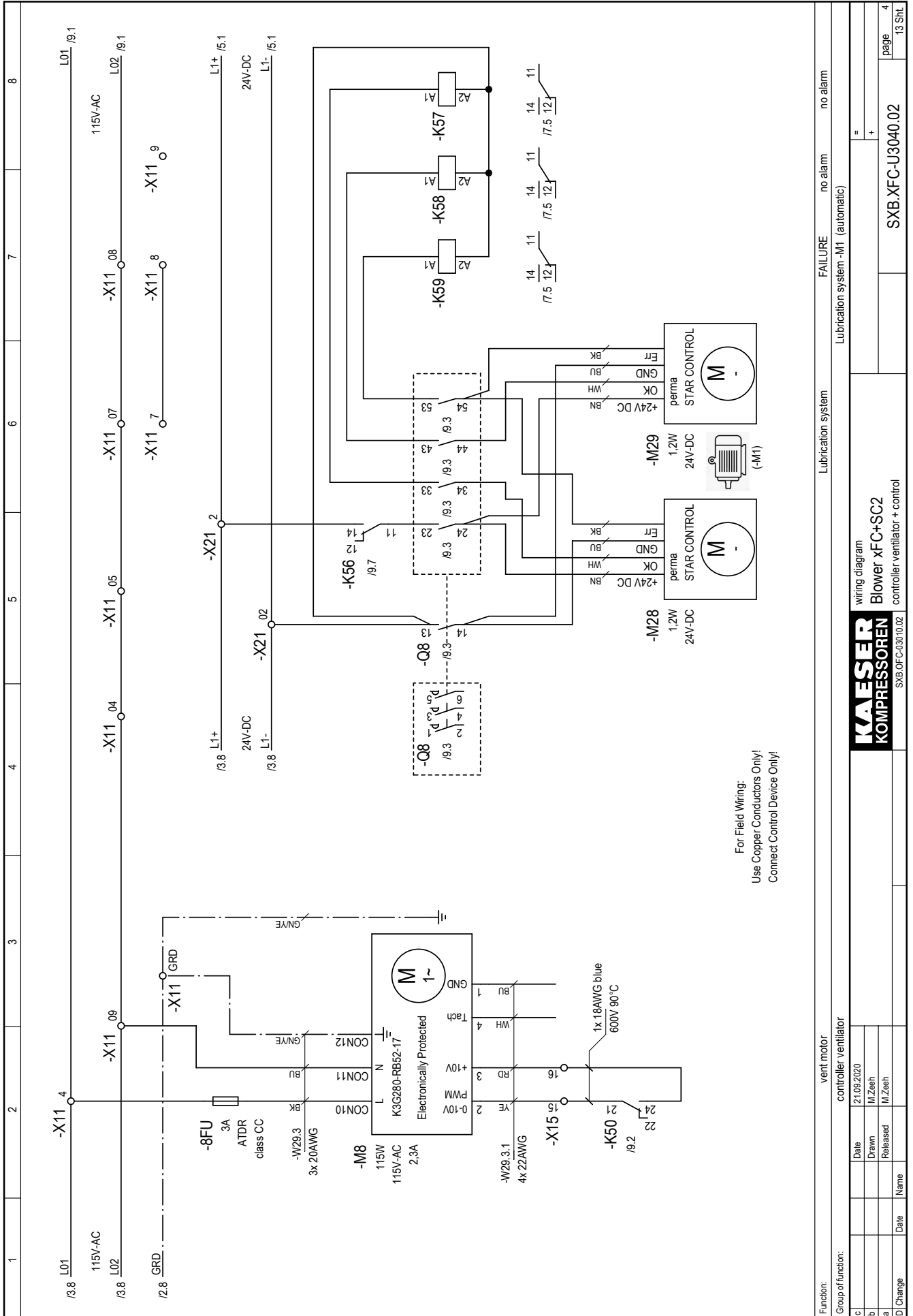

Function:		vent motor	
Group of function:		controller ventilator	
c	Date	21.09.2020	
b	Drawn	M.Zeesh	
a	Released	M.Zeesh	
D	Change	Date	Name
wiring diagram		Blower xFC+SC2	
controler ventilator + control		SX8.0F-C-03010.02	
Lubrication system		Lubrication system-M11 (automatic)	
FAILURE		no alarm	
no alarm		no alarm	
SX8.XFC-U3040.02		page 4	
		13 Sht	

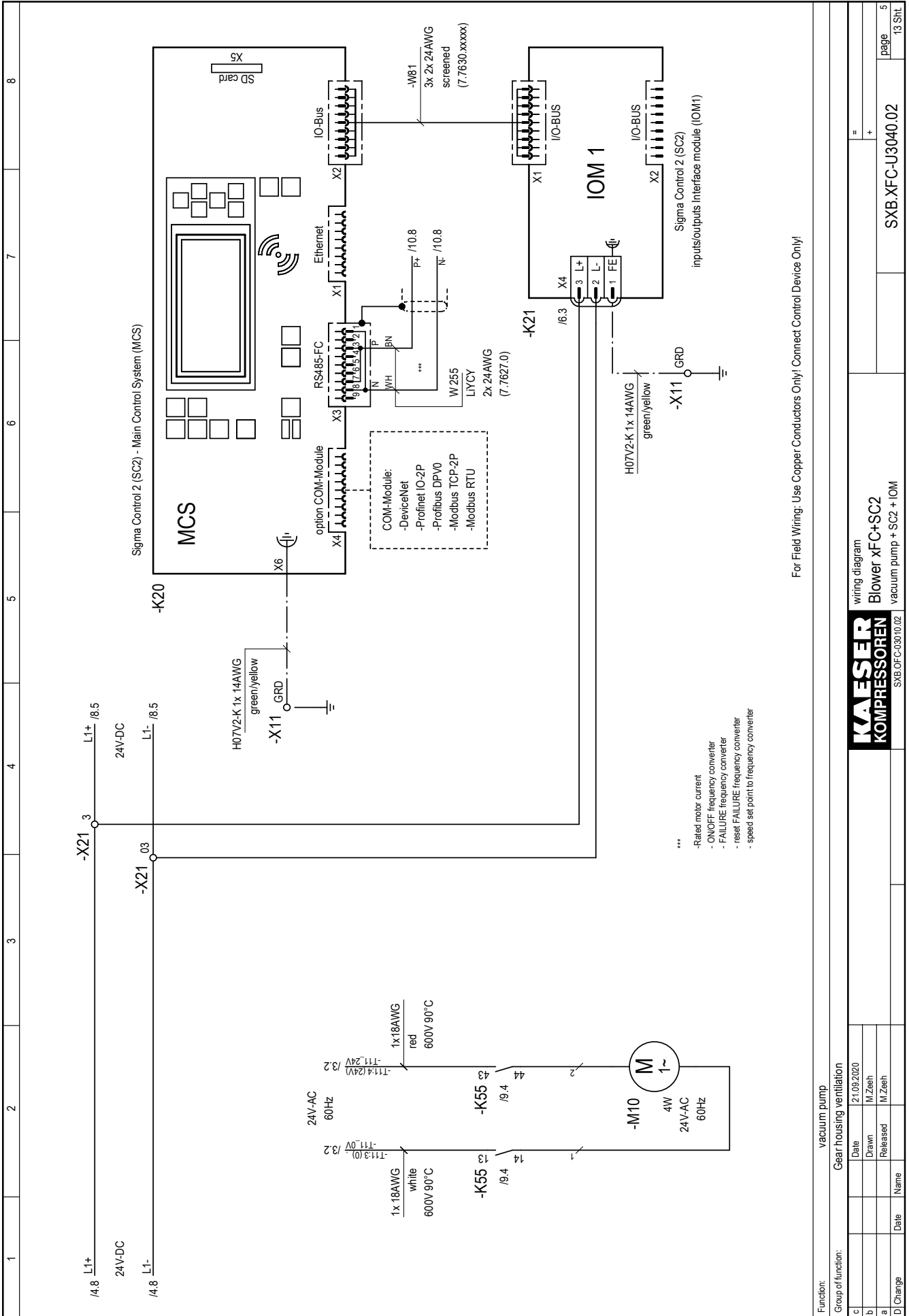

For Field Wiring: Use Copper Conductors Only! Connect Control Device Only!

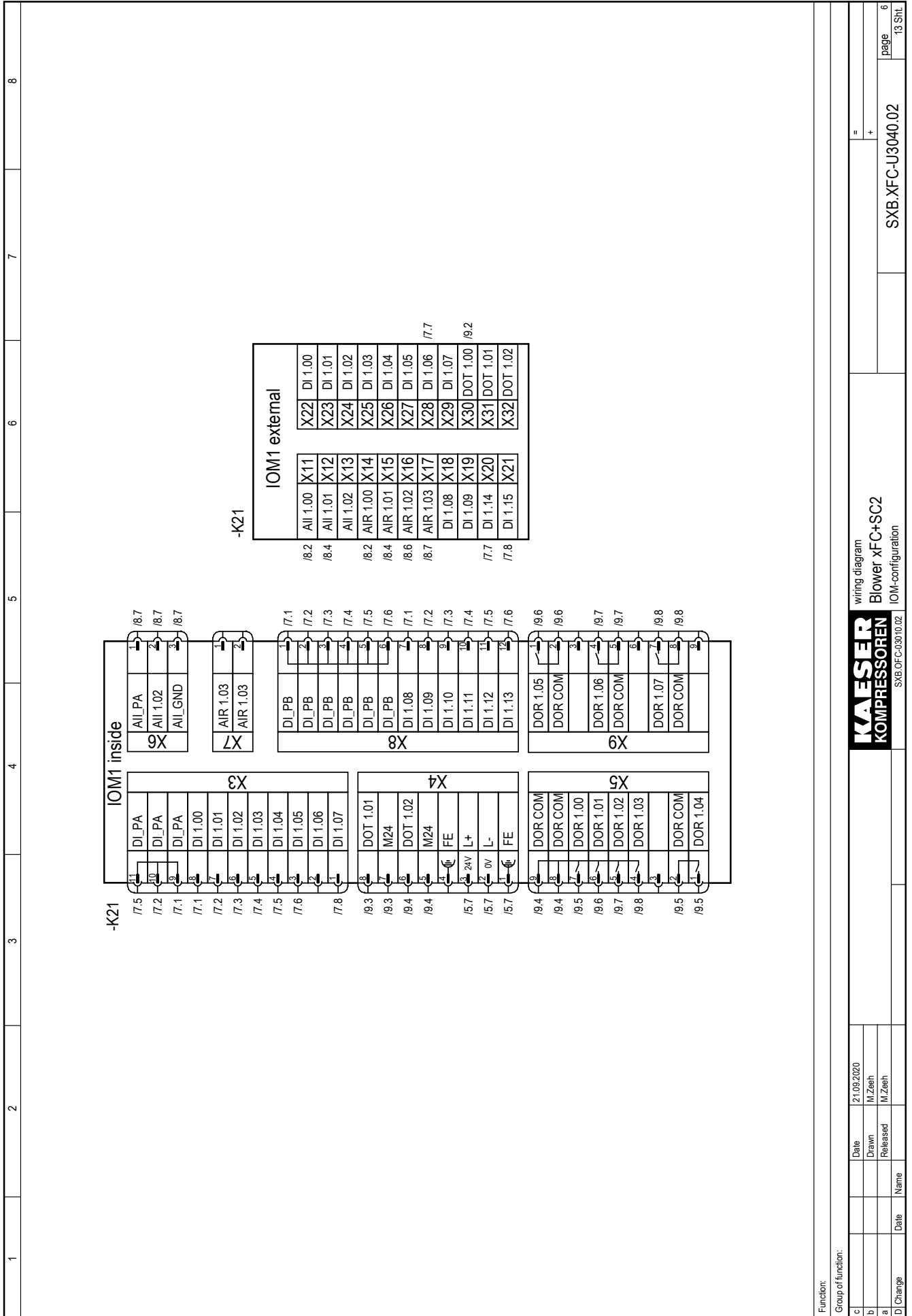

Function:		wiring diagram	
Group of function:		Blower xFC+SC2	
Date		21.09.2020	
Drawn		M.Zeeh	
Released		M.Zeeh	
Date		Name	
D/Change		Date	
		=	
		+	
		SX.B.XFC-U3040.02	
		page	
		6	
		13 Sht	

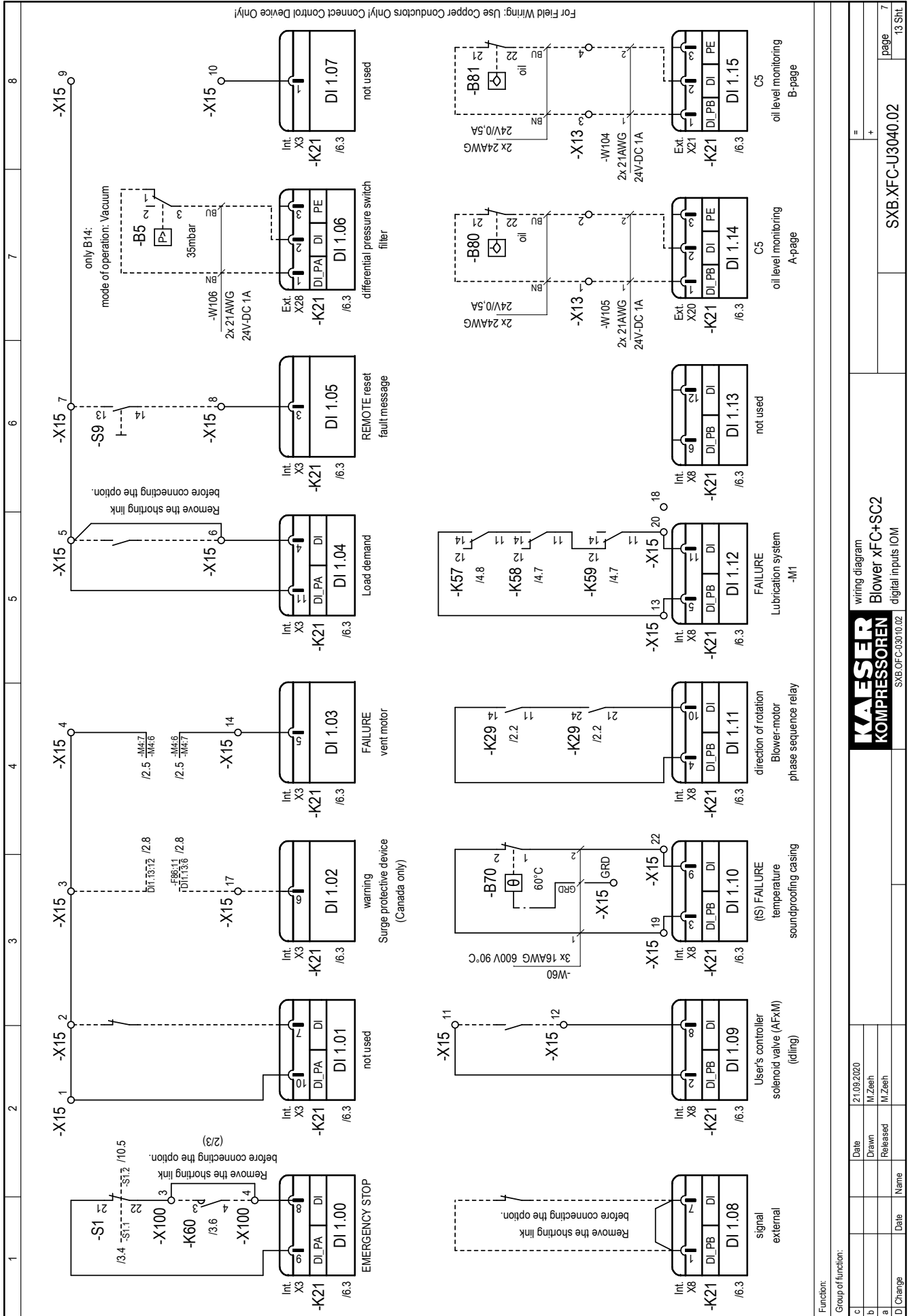

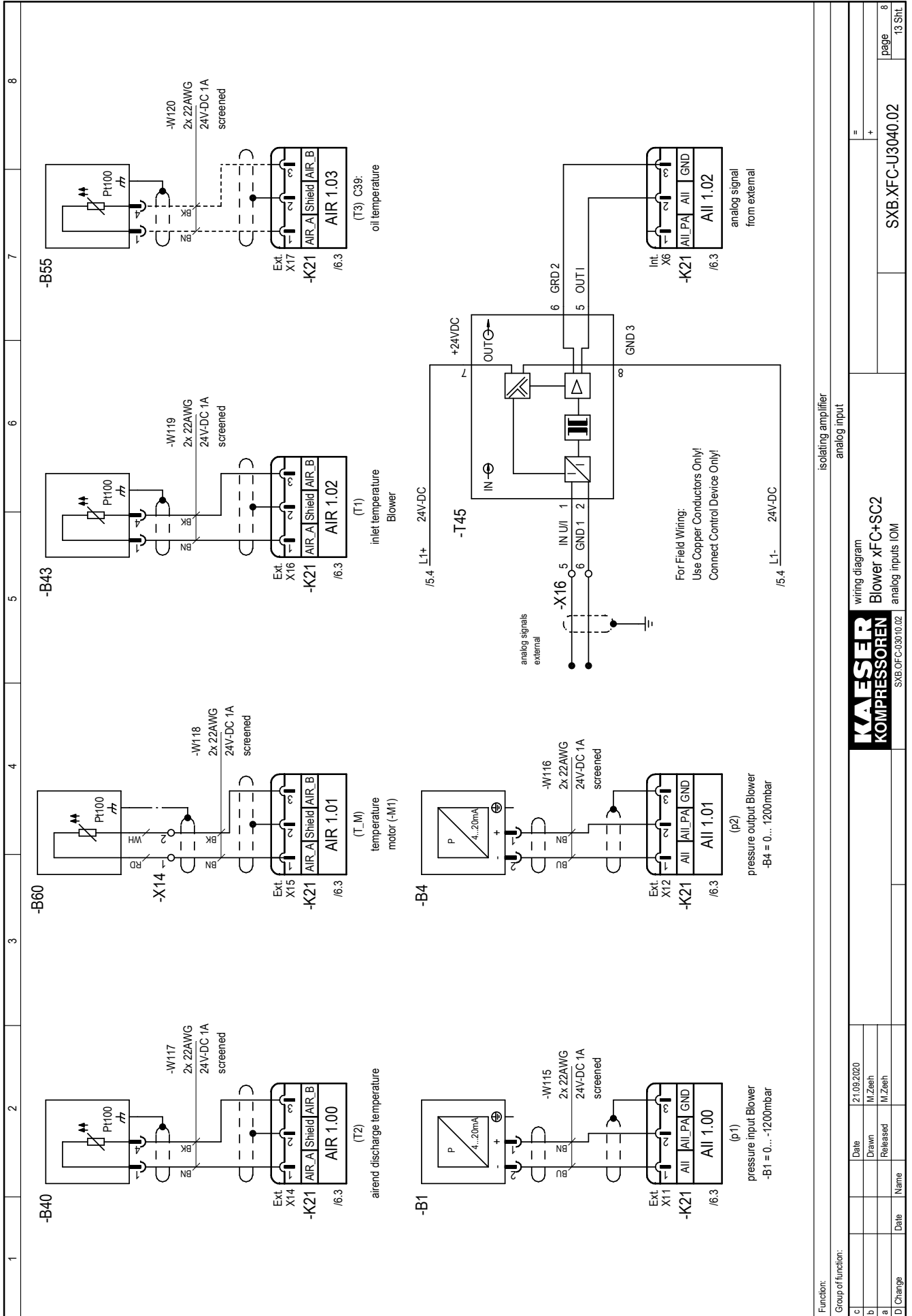

Function:		wiring diagram	
Group of function:		Blower xFC+SC2 digital inputs IOM	
c	Date	21.09.2020	page 7
b	Drawn	M.Zeesh	13 Sht
a	Released	M.Zeesh	
D	Change	Date	Name
SX8 OF C-03010.02		SX8.XFC-U3040.02	

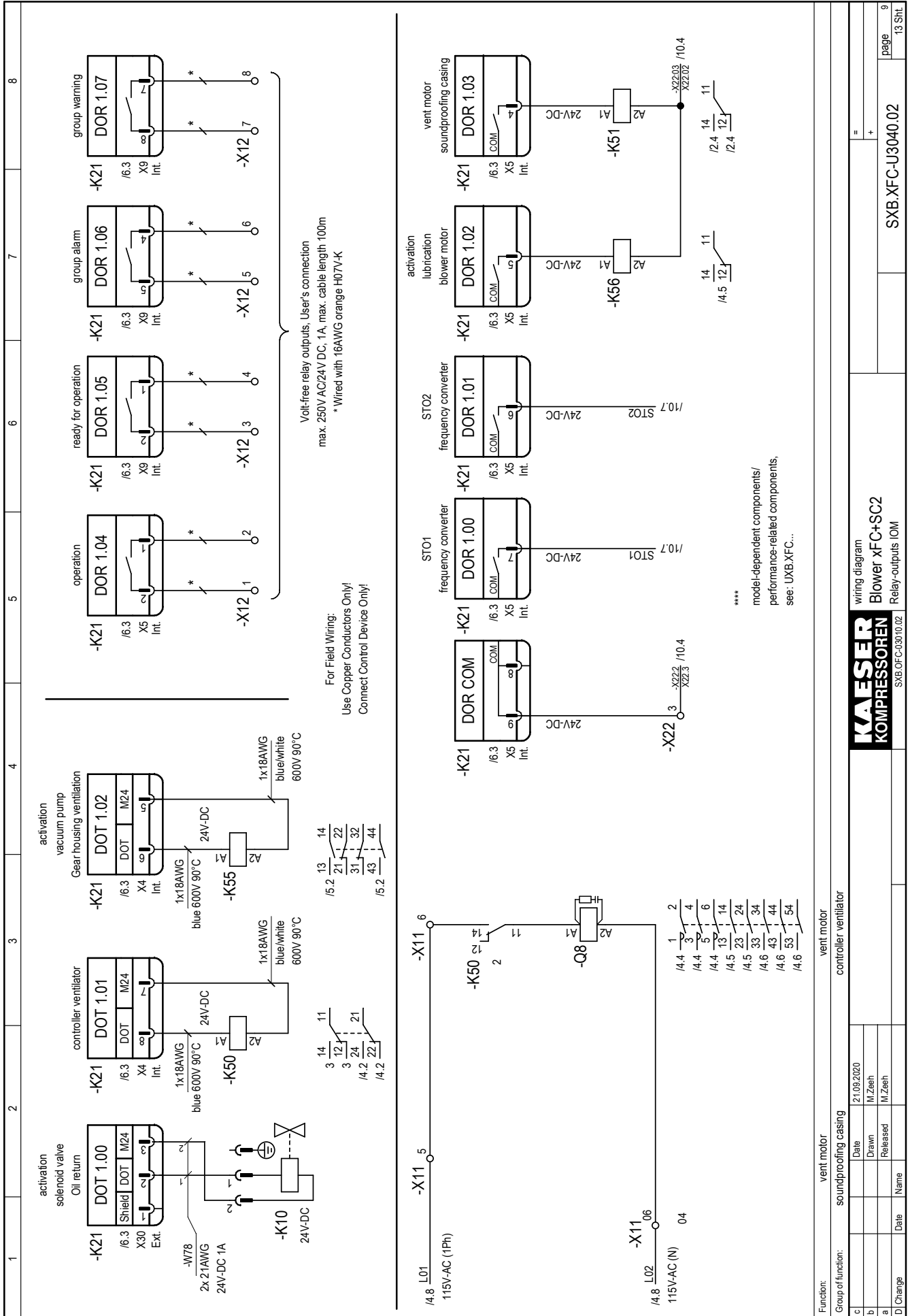

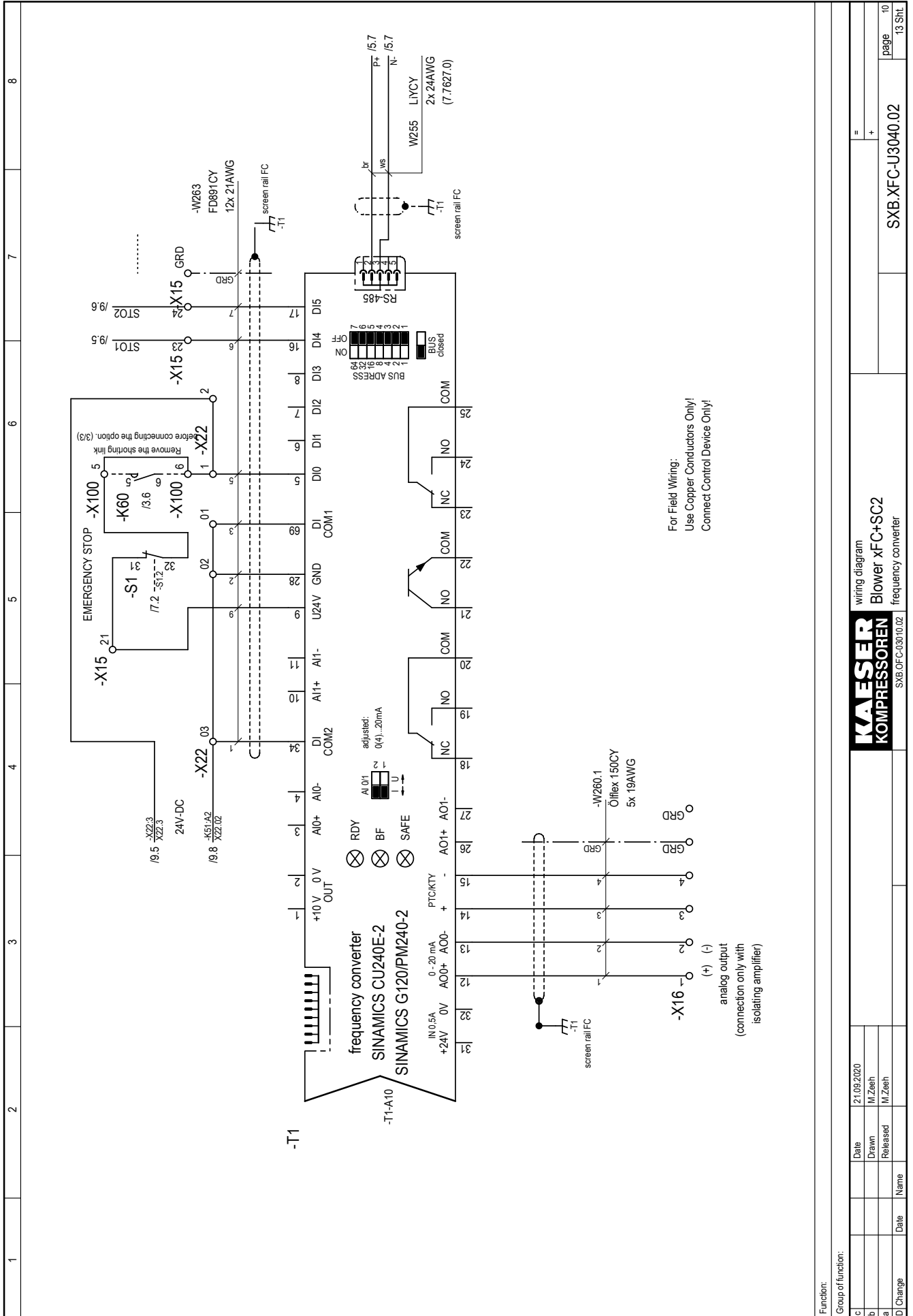

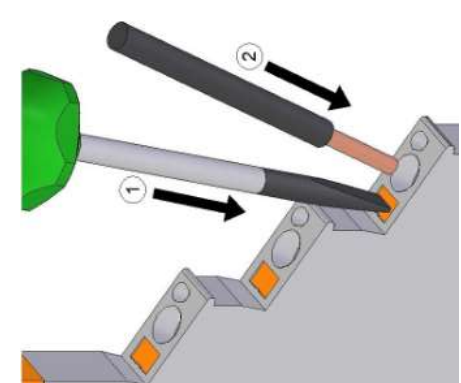

1	2	3	4	5	6	7	8
<p>fig.: 1 Handling control line terminal</p> 							
Function:							
Group of function:							
c	Date	21.09.2020					
b	Drawn	M.Zeesh					
a	Released	M.Zeesh					
D	Change	Date	Name				
					wiring diagram Blower xFC+SC2 Handling terminals		
			SXB OF C-03010.02		SXB.XFC-U3040.02		
					= +		page 11 13 Sht

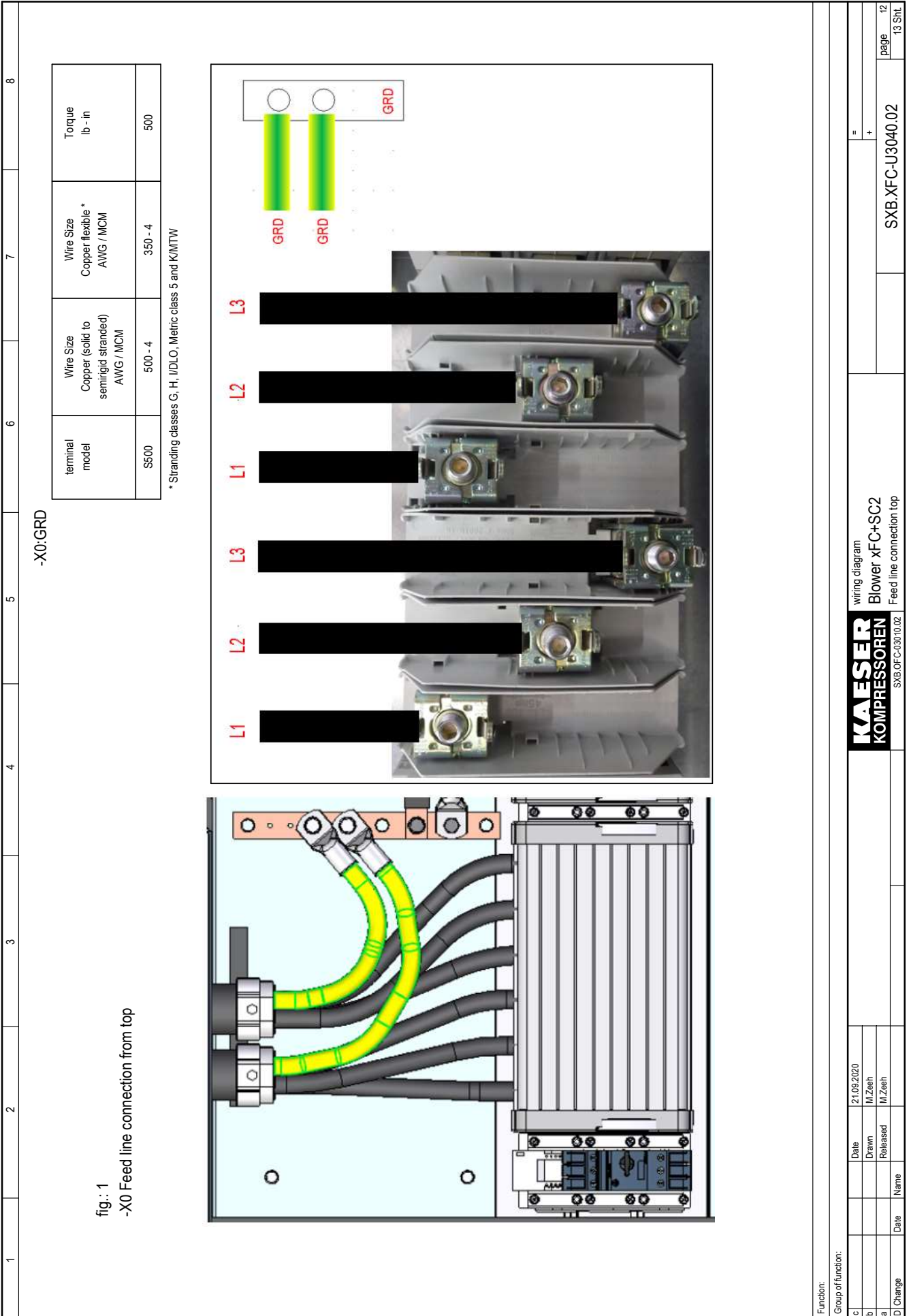

12345678

-X0:GRD

fig.: 1
-X0 Feed line connection from bottom

terminal model	Wire Size Copper (solid to semirigid stranded) AWG / MCM	Wire Size Copper flexible * AWG / MCM	Torque lb.-in
SS00	500 - 4	350 - 4	500

* Stranding classes G, H, IDLO, Metric class 8 and K/MTW

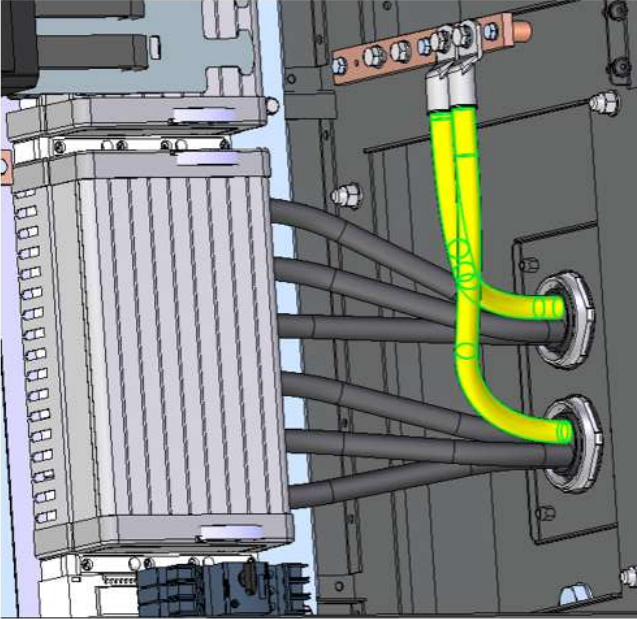
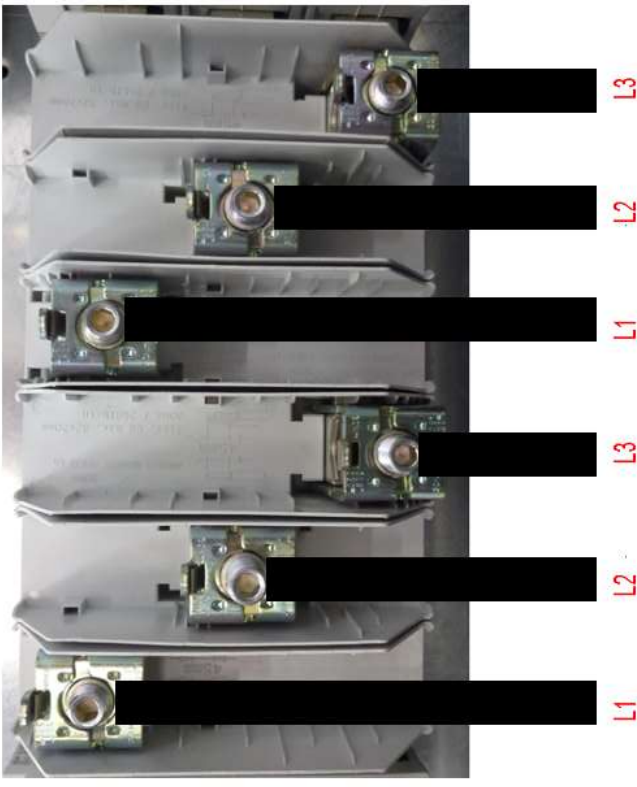
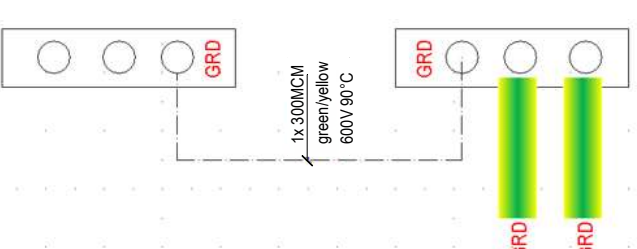
Function:
Group of function:

c	Date	21.09.2020
b	Drawn	M.Zeesh
a	Released	M.Zeesh
D	Change	Date Name

wiring diagram
Blower xFC+SC2
Feed line connection bottom

	=
SX.B.XFC-U3040.02	+
SX.B.XFC-U3040.02	page 13
13 Sht	13 Sht

change no.	date	name
c	21.09.2020	
b		
a		
H		

terminal strip	destination	connection	terminal-no.	link	terminal legend	location	name of device	connection
terminal strip: -X0								
total 9 terminals								
		supply	GRD	•		1/6	unit frame	
			GRD	•		1/6	X11	
			GRD	•		1/6	control panel	
		supply	U1	•		1/3	U1	
			U1	•		1/3	F1	
		supply	V1	•			V1	
			V1	•			F1	
		supply	W1	•			W1	
			W1	•			F1	
			F1	•			F1	
			F1	•			F1	
			W1	•			W1	
			W1	•			F1	
			F1	•			F1	
			F1	•			F1	
			W1	•			W1	
			W1	•			F1	
			F1	•			F1	
			F1	•			F1	
			W1	•			W1	
			W1	•			F1	
			F1	•			F1	
			F1	•			F1	
			W1	•			W1	
			W1	•			F1	
			F1	•			F1	
			F1	•			F1	
			W1	•			W1	
			W1	•			F1	
			F1	•			F1	
			F1	•			F1	
			W1	•			W1	
			W1	•			F1	
			F1	•			F1	
			F1	•			F1	
			W1	•			W1	
			W1	•			F1	
			F1	•			F1	
			F1	•			F1	
			W1	•			W1	
			W1	•			F1	
			F1	•			F1	
			F1	•			F1	
			W1	•			W1	
			W1	•			F1	
			F1	•			F1	
			F1	•			F1	
			W1	•			W1	
			W1	•			F1	
			F1	•			F1	
			F1	•			F1	
			W1	•			W1	
			W1	•			F1	
			F1	•			F1	
			F1	•			F1	
			W1	•			W1	
			W1	•			F1	
			F1	•			F1	
			F1	•			F1	
			W1	•			W1	
			W1	•			F1	
			F1	•			F1	
			F1	•			F1	
			W1	•			W1	
			W1	•			F1	
			F1	•			F1	
			F1	•			F1	
			W1	•			W1	
			W1	•			F1	
			F1	•			F1	
			F1	•			F1	
			W1	•			W1	
			W1	•			F1	
			F1	•			F1	
			F1	•			F1	
			W1	•			W1	
			W1	•			F1	
			F1	•			F1	
			F1	•			F1	
			W1	•			W1	
			W1	•			F1	
			F1	•			F1	
			F1	•			F1	
			W1	•			W1	
			W1	•			F1	
			F1	•			F1	
			F1	•			F1	
			W1	•			W1	
			W1	•			F1	
			F1	•			F1	
			F1	•			F1	
			W1	•			W1	
			W1	•			F1	
			F1	•			F1	
			F1	•			F1	
			W1	•			W1	
			W1	•			F1	
			F1	•			F1	
			F1	•			F1	
			W1	•			W1	
			W1	•			F1	
			F1	•			F1	
			F1	•			F1	
			W1	•			W1	
			W1	•			F1	
			F1	•			F1	
			F1	•			F1	
			W1	•			W1	
			W1	•			F1	
			F1	•			F1	
			F1	•			F1	
			W1	•			W1	
			W1	•			F1	
			F1	•			F1	
			F1	•			F1	
			W1	•			W1	
			W1	•			F1	
			F1	•			F1	
			F1	•			F1	
			W1	•			W1	
			W1	•			F1	
			F1	•			F1	
			F1	•			F1	
			W1	•			W1	
			W1	•			F1	
			F1	•			F1	
			F1	•			F1	
			W1	•			W1	
			W1	•			F1	
			F1	•			F1	
			F1	•			F1	
			W1	•			W1	
			W1	•			F1	
			F1	•			F1	
			F1	•			F1	
			W1	•			W1	
			W1	•			F1	
			F1	•			F1	
			F1	•			F1	
			W1	•			W1	
			W1	•			F1	
			F1	•			F1	
			F1	•			F1	
			W1	•			W1	
			W1	•			F1	
			F1	•			F1	
			F1	•			F1	
			W1	•			W1	
			W1	•			F1	
			F1	•			F1	
			F1	•			F1	
			W1	•			W1	
			W1	•			F1	
			F1	•			F1	
			F1	•			F1	
			W1	•			W1	
			W1	•			F1	
			F1	•			F1	
			F1	•			F1	
			W1	•			W1	
			W1	•			F1	
			F1	•			F1	
			F1	•			F1	
			W1	•			W1	
			W1	•			F1	
			F1	•			F1	
			F1	•			F1	
			W1	•			W1	
			W1	•			F1	
			F1	•			F1	
			F1	•			F1	
			W1	•			W1	
			W1	•			F1	
			F1	•			F1	
			F1	•			F1	
			W1	•			W1	
			W1	•			F1	
			F1	•			F1	
			F1	•			F1	
			W1	•			W1	
			W1	•			F1	
			F1	•			F1	
			F1	•			F1	
			W1	•			W1	
			W1	•			F1	
			F1	•			F1	
			F1	•			F1	
			W1	•			W1	
			W1	•			F1	
			F1	•			F1	
			F1	•			F1	
			W1	•			W1	
			W1	•			F1	
			F1	•			F1	
			F1	•			F1	
			W1	•			W1	
			W1	•			F1	
			F1	•			F1	
			F1	•			F1	
			W1	•			W1	
			W1	•			F1	
			F1	•			F1	

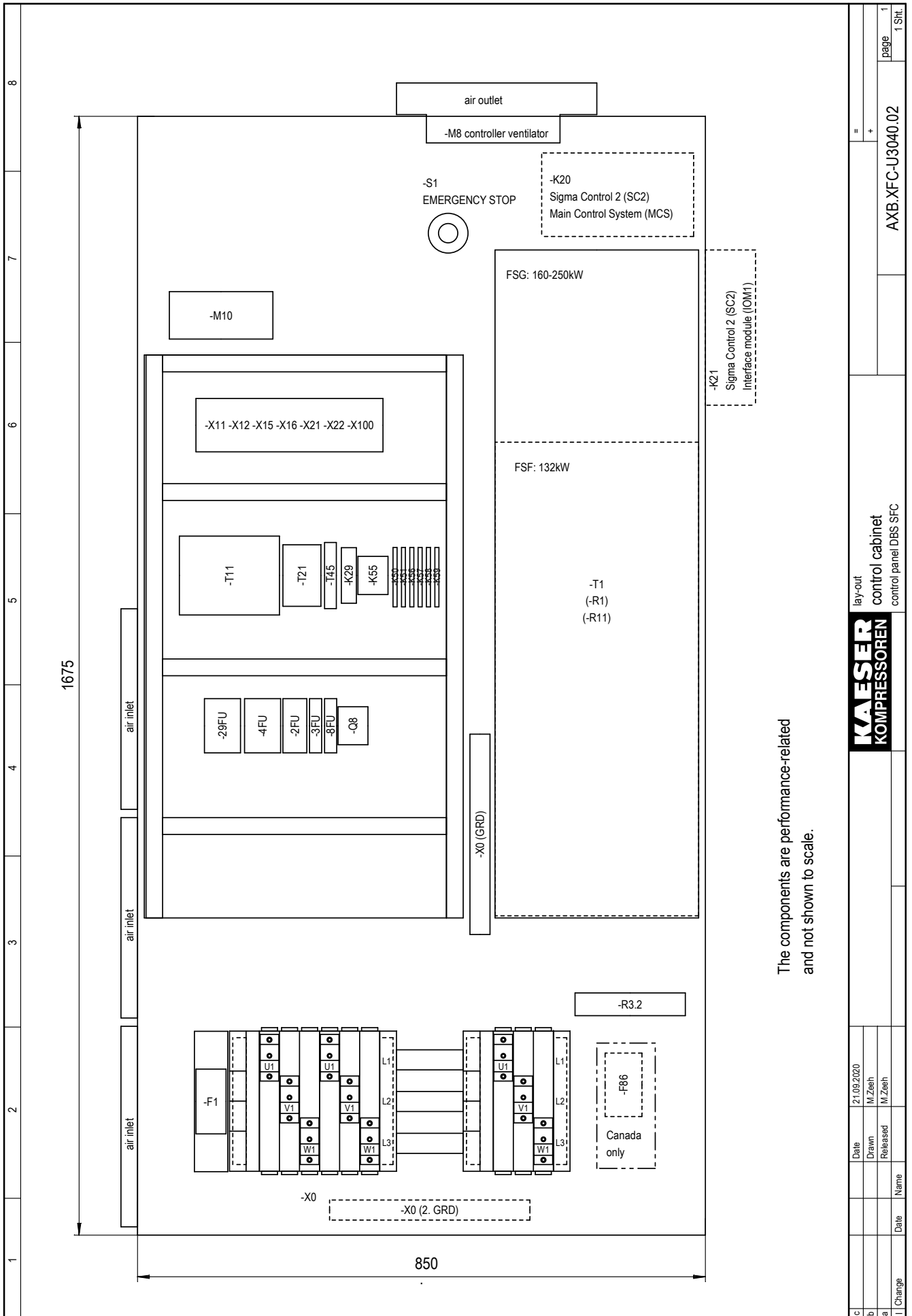

The components are performance-related and not shown to scale.

Date		21.09.2020		=		+		AXB.XFC-U3040.02		page 1	
Drawn		M.Zeesh		control cabinet		control panel DBS SFC				1 Sht.	
Released		M.Zeesh		control panel DBS SFC							
Name											
Date											
Change											

13.5 Project planning data