

# Operator Manual

Refrigerated Dryer

TC

No.: 9\_5777 24 USE

PRELIMINARY  
Subject to Revision

Manufacturer:

**KAESER KOMPRESSOREN SE**

96410 Coburg • PO Box 2143 • GERMANY • Tel. +49-(0)9561-6400 • Fax +49-(0)9561-640130

[www.kaeser.com](http://www.kaeser.com)

PRELIMINARY  
Subject to Revision

Original instructions  
/KKW/DTC 2.04 en Z1 SBA-TROCKNER

20190917 110720

<b>1</b>	<b>Regarding this Document</b>	
1.1	Using this document .....	1
1.2	Further documents .....	1
1.3	Copyright .....	1
1.4	Symbols and labels .....	1
1.4.1	Warnings .....	1
1.4.2	Potential damage warnings .....	2
1.4.3	Other alert notes and their symbols .....	2
<b>2</b>	<b>Technical Data</b>	
2.1	Nameplate .....	4
2.2	Options .....	5
2.3	Weight .....	5
2.4	Ambient conditions .....	5
2.5	Compressed air system .....	5
2.6	Refrigerant circuit .....	6
2.7	Sound pressure level .....	7
2.8	Electrical connection .....	7
2.9	Power supply specifications .....	7
<b>3</b>	<b>Safety and Responsibility</b>	
3.1	Basic instructions .....	9
3.2	Specified use .....	9
3.3	Improper use .....	9
3.4	User's responsibilities .....	9
3.4.1	Observe statutory and universally accepted regulations .....	9
3.4.2	Qualified personnel .....	10
3.5	Dangers .....	10
3.5.1	Safely dealing with sources of danger .....	10
3.5.2	Safe machine operation .....	12
3.5.3	Organizational Measures .....	13
3.5.4	Danger Areas .....	14
3.6	Safety devices .....	14
3.7	Safety signs .....	14
3.8	Emergencies .....	16
3.8.1	Fire fighting .....	16
3.8.2	Injury from Handling Refrigerant .....	16
3.9	Warranty .....	17
3.10	Environment protection .....	17
<b>4</b>	<b>Design and Function</b>	
4.1	Enclosure .....	18
4.2	Machine function .....	18
4.3	SECOTEC CONTROL .....	19
4.4	SECOTEC CONTROL switches and indicators .....	20
4.4.1	Pressure dew point indicator .....	20
4.5	Electronic condensate drain .....	21
4.6	Safety devices .....	21
4.7	Options .....	22
4.7.1	Machine Mountings .....	22
4.7.2	Electronic condensate drain with floating relay contact .....	22
4.7.3	Pressure dew point warning .....	22
4.7.4	Floating relay contacts .....	22
4.8	Accessories .....	23
4.8.1	Bypass line .....	23
4.8.2	Transformer .....	23

<b>5</b>	<b>Installation and Operating Conditions</b>	
5.1	Ensuring safety .....	24
5.2	Installation conditions .....	24
5.2.1	Determining location and clearances .....	24
5.2.2	Ensuring adequate ventilation .....	25
5.2.3	Exhaust duct design .....	26
5.3	Operating the machine in a compressed air network .....	26
<b>6</b>	<b>Installation</b>	
6.1	Ensuring safety .....	27
6.2	Reporting Transport Damage .....	28
6.3	Making the compressed air connection .....	28
6.4	Connecting the condensate drain .....	29
6.5	Connecting the machine with the power supply .....	30
6.6	Options .....	31
6.6.1	Anchoring the machine .....	31
6.7	Connecting relay contacts to the condensate drain .....	31
6.8	Installing a bypass line (accessory) .....	32
<b>7</b>	<b>Initial Start-up</b>	
7.1	Ensuring safety .....	33
7.2	Instructions to be observed before commissioning or re-commissioning .....	33
7.3	Checking installation and operating conditions .....	34
7.4	Starting the machine for the first time .....	34
<b>8</b>	<b>Operation</b>	
8.1	Switching on and off .....	36
8.1.1	Switching on .....	36
8.1.2	Switching off .....	36
8.2	RESETTING the Machine .....	37
<b>9</b>	<b>Fault Recognition and Rectification</b>	
9.1	Basic instructions .....	38
9.2	Faults .....	38
<b>10</b>	<b>Maintenance</b>	
10.1	Ensuring safety .....	39
10.2	Regular maintenance tasks .....	40
10.3	Regular service tasks .....	40
10.4	Cleaning the refrigerant condenser .....	40
10.5	Electronic condensate drain .....	41
10.5.1	Check condensate drain .....	41
10.5.2	Replace the service unit .....	42
<b>11</b>	<b>Spares, Operating Materials, Service</b>	
11.1	Note the nameplate .....	45
11.2	Consumable parts and operating materials .....	45
11.3	KAESER AIR SERVICE .....	45
11.4	Replacement parts for service and repair .....	45
<b>12</b>	<b>Decommissioning, Storage and Transport</b>	
12.1	Decommissioning .....	51
12.2	Storage .....	51
12.3	Transport .....	51
12.3.1	Safety .....	51
12.3.2	Transport with a forklift truck .....	52
12.3.3	Transport with a crane .....	52
12.4	Disposal .....	53

<b>13</b>	<b>Annex</b>	
13.1	Dimensional drawing .....	55
13.2	Pipeline and instrument flow diagram (P+I diagram) .....	58
13.3	Electrical Diagram .....	61

PRELIMINARY  
Subject to Revision

PRELIMINARY  
Subject to Revision

Fig. 1	Location of safety signs .....	15
Fig. 2	Enclosure overview .....	18
Fig. 3	Machine overview .....	19
Fig. 4	SECOTEC CONTROL switches and indicators .....	20
Fig. 5	Pressure dew point indicator .....	21
Fig. 6	Machine Mountings .....	22
Fig. 7	Recommended machine placement and dimensions [in.] .....	25
Fig. 8	Compressed air connection .....	28
Fig. 9	Connecting the condensate drain .....	30
Fig. 10	Option K6: Connecting relay contacts to the condensate drain .....	32
Fig. 11	Bypass line .....	32
Fig. 12	Switching on and off .....	36
Fig. 13	Safety pressure switch .....	37
Fig. 14	Cleaning the refrigerant condenser .....	41
Fig. 15	Check condensate drain .....	42
Fig. 16	Option K5/K6: Removing the service unit .....	43
Fig. 17	Transporting with a forklift truck .....	52
Fig. 18	Transport with a crane .....	53

PRELIMINARY  
Subject to Revision

PRELIMINARY  
Subject to Revision



Tab. 1	Danger levels and their definition (personal injury) .....	1
Tab. 2	Danger levels and their definition (damage to property) .....	2
Tab. 3	Machine nameplate .....	4
Tab. 4	Options .....	5
Tab. 5	Weight .....	5
Tab. 6	Ambient conditions .....	5
Tab. 7	Compressed air system .....	5
Tab. 8	Refrigerant circuit .....	6
Tab. 9	Sound pressure level .....	7
Tab. 10	Supply data 115V / 1 / 60Hz .....	7
Tab. 11	Supply data 230V / 1 / 60Hz .....	8
Tab. 12	Danger Areas .....	14
Tab. 13	Safety signs .....	15
Tab. 14	Switches and indicators .....	20
Tab. 15	Pressure dew point indicator .....	21
Tab. 16	Pressure dew point and consequences .....	21
Tab. 17	Condensate line .....	29
Tab. 18	Condensate collecting line .....	29
Tab. 19	Condensate collecting line: Line cross-section .....	29
Tab. 20	Re-commissioning after storage .....	34
Tab. 21	Installation conditions checklist .....	34
Tab. 22	Faults and remedies .....	38
Tab. 23	Regular maintenance tasks .....	40
Tab. 24	Regular service tasks .....	40
Tab. 25	Consumable parts .....	45

PRELIMINARY  
Subject to Revision

# 1 Regarding this Document

## 1.1 Using this document

The operating manual is a component of the product. It describes the machine as it was at the time of first delivery after manufacture.

- Keep the operating manual in a safe place throughout the life of the machine.
- Supply any successive owner or user with this operating manual.
- Please insert any amendment or revision of the operating manual sent to you.
- Enter details from the machine nameplate and individual items of equipment in the table in chapter 2.

## 1.2 Further documents

Further documents included with this operating manual are:

- Declaration of Conformity in accordance with applicable directives.

Missing documents can be requested from KAESER.

- Make sure all documents are complete and observe the instructions contained in them.
- Make sure you provide the data from the nameplate when ordering documents.

## 1.3 Copyright

This operator manual is copyright protected. Queries regarding use or duplication of the documentation should be referred to KAESER. Correct use of information will be fully supported.

## 1.4 Symbols and labels

- Please note the symbols and labels used in this document.

### 1.4.1 Warnings

Warning notices indicate danger potentially resulting in personal injury, if the measures specified are not taken.

Warning notices indicate three levels of danger identified by the corresponding signal term:

Signal term	Meaning	Consequences of non-compliance
DANGER	Warns of imminent danger	Will very likely result in death or severe injury
WARNING	Warns of potentially imminent danger	May result in death or severe injury
CAUTION	Warns of a potentially dangerous situation	May result in moderate physical injury

Tab. 1 Danger levels and their definition (personal injury)

Warning notices preceding a chapter apply to the entire chapter including all sub-sections.

Example:

# 1 Regarding this Document

## 1.4 Symbols and labels

### **⚠ DANGER**

*The type and source of the imminent danger is shown here!*

*The possible consequences of ignoring a warning are shown here.*

*The word "DANGER" indicates that death or severe injury can very likely result from ignoring the warning.*

➤ *The measures required to protect yourself from danger are shown here.*

Warning notes referring to a sub-section or the subsequent action are integrated into the procedure and numbered as a step.

Example:

1. **⚠ WARNING** *The type and source of the imminent danger is shown here!*  
*The possible consequences of ignoring a warning are shown here.*  
*The word "WARNING" indicates that death or severe injury may result from ignoring the warning.*  
➤ *The measures required to protect yourself from danger are shown here.*
2. Always read and comply with warning instructions.

### 1.4.2 Potential damage warnings

Contrary to the warnings shown above, damage warnings do not indicate potential personal injury.

Damage warnings have only one danger level, identified by this signal term:

Signal term	Meaning	Consequences of non-compliance
NOTE	Warns of a potentially dangerous situation	Damage to property is possible

Tab. 2 Danger levels and their definition (damage to property)

Example:

### **NOTICE**

*The type and source of the imminent danger is shown here!*

*Potential effects when ignoring the warning are indicated here.*



➤ *The protective measures against the damages are shown here.*

➤ Carefully read and fully comply with warnings against damages.

### 1.4.3 Other alert notes and their symbols



This symbol indicates particular important information.

- Material Here you will find details on special tools, operating materials or spare parts.
- Precondition Here you will find conditional requirements necessary to carry out the task.  
The conditional requirements relevant to safety shown here will help you to avoid dangerous situations.
- Option H1 ➤ This symbol is placed by lists of actions comprising one stage of a task.  
Operating instructions with several steps are numbered in the sequence of the operating steps.  
Information relating to one option only are marked with an option code (e.g., H1 indicates that this section applies only to machines with bolt-down machine feet). Option codes used in this operating manual are explained in chapter 2.2.
-  Information referring to potential problems is identified by a question mark.  
The cause is specified in the help text ...  
➤ ... as is a solution.
-  This symbol identifies important information or measures regarding the protection of the environment.
- Further information Further subjects are introduced here.

## 2 Technical Data

### 2.1 Nameplate

#### Machine nameplate

The model designation and important technical information are given on the machine's nameplate. The nameplate is located on the outside of the machine.



Nameplates in various languages are provided with the machine.

➤ If required, attach a nameplate in the applicable language.

➤ Enter the data from the nameplate here for reference.

Feature	Value
Model	
Material no.	
Serial No.	
Year of manufacture	
Max. gauge working pressure	
Compressed air inlet temperature	
Ambient temperature	
Rated current	
Largest motor FLA	
Short circuit current	
Supply fuse (field provided)	
Rate power supply	
Wiring diagram	
Option	
<b>Refrigerant system</b>	
(Contains fluoridated global warming gas)	
Refrigerant	
Refrigerant charge	
Global warming potential (GWP)	
CO <sub>2</sub> equivalent	
Max. working pressure, HP*	
Max. working pressure, LP**	
Tightness checked	
* High pressure	
** Low pressure	

Tab. 3 Machine nameplate

## 2.2 Options

The table contains a list of possible options.

➤ Enter options here as a reference:

Option	Option code	Provided?
Floating contact: "Pressure dew point warning"	C36	
Floating contact: "Refrigerant compressor runs"	C37	
Electronic condensate drain	K5	
Electronic condensate drain, floating contact	K6	
Bolt-down machine mounts	H1	
Provided: ✓		
Not available: —		

Tab. 4 Options

## 2.3 Weight

The weight given is the maximum. Actual weights of individual machines are dependent on equipment fitted.

	TC 31	TC 36	TC 44
Weight [lb.]	342	375	441

Tab. 5 Weight

## 2.4 Ambient conditions

	TC 31	TC 36	TC 44
Maximum elevation AMSL <sup>1)</sup> [ft]	3000	3000	3000
Permissible ambient tem- perature [°F]	37–110	37–110	37–110

<sup>1)</sup> Higher altitudes are permissible only after consultation with the manufacturer.

Tab. 6 Ambient conditions

## 2.5 Compressed air system

	TC 31	TC 36	TC 44
Pressure drop <sup>1)</sup> [psi]	2.3	2.9	1.5

<sup>1)</sup> According to ISO 7183 Option A2:

- Reference point: 14.5 psia, 68 °F, 0 % relative humidity:
- Operating state: Gauge working pressure 100 psig, compressed air inlet temperature 100 °F, 100 % relative humidity, cooling air inlet temperature 100 °F

	TC 31	TC 36	TC 44
Flow rate <sup>1)</sup> [cfm]	113	138	166
Cooling air flow rate [cfm]	1320	1320	1320
Pressure dew point <sup>1)</sup> [°F]	46	46	43
Max. working pressure [psig]	230	230	230
Min. compressed air inlet temperature [°F]	40	40	40
Max. compressed air inlet temperature [°F]	130	130	130

<sup>1)</sup> According to ISO 7183 Option A2:

- Reference point: 14.5 psia, 68 °F, 0 % relative humidity:
- Operating state: Gauge working pressure 100 psig, compressed air inlet temperature 100 °F, 100 % relative humidity, cooling air inlet temperature 100 °F

Tab. 7 Compressed air system

## 2.6 Refrigerant circuit

The refrigerated dryer contains a refrigerant that is classified as a fluorinated global warming gas. This refrigerant is required for the function of the machine.

	TC 31	TC 36	TC 44
Refrigerant	R-513A	R-513A	R-513A
Global warming potential (GWP)	631	631	631
Charge quantity <sup>1)</sup> [lb]	2.34	2.43 / 2.20 <sup>2)</sup>	2.43
Charge quantity as CO <sub>1</sub> equivalent [t]	0.7	0.7 / 0.6	0.7
Maximum working pressure [psig] (high pressure end)	261	261	261
Maximum working pressure [psig] (low pressure end)	232	232	232
Pressure monitor: Cut-out pressure [psig]	261	261	261

<sup>1)</sup> Volume of fluorinated global warming gases for which the refrigerant system was designed.

<sup>2)</sup> 115 / 230 V

Tab. 8 Refrigerant circuit



## 2.7 Sound pressure level

	TC 31	TC 36	TC 44
Sound pressure level [dB(A)]	<70	<70	<70

Sound pressure level as per EN ISO 11203 and the basic standard ISO 9614-2:

- Measurement distance:  $d = 1 \text{ m}$
- Logarithmic surface ratio:  $Q_2 = 14.6 \text{ dB(A)}$
- Uncertainty:  $\pm 3 \text{ dB(A)}$

Tab. 9 Sound pressure level

## 2.8 Electrical connection

The machine is designed for an electrical supply according to National Electric Code (NEC) NEC-670, particularly NFPA 79, edition 2015, section 4.3. In the absence of any user-specified alternatives, the limits given in these standards must be adhered to. Consult manufacturer for any other specific power supply.

Other electrical supplies are not permitted.

Further information See electrical diagrams in chapter 13.3 for further information.

## 2.9 Power supply specifications

The following multi-strand copper core wires are given according to 2017 NEC 310.15 and table 310.15(B)(16) adjusted for 40 °C ambient temperature.

If other local conditions prevail, like for example high temperature, the cross section should be checked and adjusted according to 2017 NEC 110.14(C), 220.3, 310.15, table 310.15(B)(2)(a), table 310.15(B)(3)(a), 430.6, 430.22, 430.24, 670.4(A) and other local codes.

Dual element time delay fuses are selected according to 2017 NEC 240.6, 430.52 and tables 430.52, 430.248 and 430.250.

It is recommended to use a ground conductor the same size as the current carrying conductors, if local codes allow. Neither the minimum ground wire size as pointed out in 2017 NEC table 250.122 nor using conduit as the sole ground connection is recommended.

**Rated voltage: 115V / 1 / 60Hz**

	TC 31	TC 36	TC 44
Power consumption <sup>1)</sup> [hp]	1.3	1.4	—
Maximum power consumption [hp]	1.7	1.8	—
Main fuse [A]	15	20	—

<sup>1)</sup> According to ISO 7183 Option A2:

- Reference point: 14.5 psia, 68 °F, 0 % relative humidity:
- Operating state: Gauge working pressure 100 psig, compressed air inlet temperature 100 °F, 100 % relative humidity, cooling air inlet temperature 100 °F

	TC 31	TC 36	TC 44
Supply per phase and ground	AWG14	AWG12	—
Full load current [A]	14.8	15.2	—

<sup>1)</sup> According to ISO 7183 Option A2:

- Reference point: 14.5 psia, 68 °F, 0 % relative humidity:
- Operating state: Gauge working pressure 100 psig, compressed air inlet temperature 100 °F, 100 % relative humidity, cooling air inlet temperature 100 °F

Tab. 10 Supply data 115V / 1 / 60Hz

**Rated voltage: 230V / 1 / 60Hz**

	TC 31	TC 36	TC 44
Power consumption <sup>1)</sup> [hpW]	1.5	1.6	1.8
Maximum power consumption [hp]	1.8	2.1	2.5
Main fuse [A]	15	15	15
Supply per phase and ground	AWG14	AWG14	AWG14
Full load current [A]	7.2	7.8	9.3

<sup>1)</sup> According to ISO 7183 Option A2:

- Reference point: 14.5 psia, 68 °F, 0 % relative humidity:
- Operating state: Gauge working pressure 100 psig, compressed air inlet temperature 100 °F, 100 % relative humidity, cooling air inlet temperature 100 °F

Tab. 11 Supply data 230V / 1 / 60Hz

## 3 Safety and Responsibility

### 3.1 Basic instructions

The machine is manufactured to the latest engineering standards and acknowledged safety regulations. Nevertheless, dangers can arise through its operation:

- danger to life and limb of the operator or third parties,
- impairments to the machine and other material assets.



Disregard of warning or safety instructions can cause serious injuries!

- Use this machine only if it is in a technically perfect condition and only for the purpose for which it is intended; observe all safety measures and the instructions in the service manual.
- Immediately rectify (have rectified) any faults that could be detrimental to safety!

### 3.2 Specified use

The machine is intended solely to dry compressed air for industrial use. Any other use is considered incorrect. The manufacturer is not liable for any damages that may result from incorrect use. The user alone is liable for any risks incurred.

- Comply with the specifications shown in this service manual.
- Operate the machine only within its performance limits and under the permitted ambient conditions.
- Do not use compressed air for breathing purposes unless it is specifically treated.
- Do not use compressed air for any application that will bring it into direct contact with food products unless it is specifically treated.

### 3.3 Improper use

Improper usage can cause damage to property and/or (severe) injuries.

- Only use the machine as intended.
- Never direct compressed air at persons or animals.
- Do not use untreated compressed air for breathing purposes.
- Do not allow the machine to take in toxic, acidic, flammable or explosive gases or vapors.
- Do not operate the machine in areas in which specific requirements with regard to explosion protection are in force.

### 3.4 User's responsibilities

#### 3.4.1 Observe statutory and universally accepted regulations

This includes, for example, nationally implemented European directives and/or applicable national legislation, safety and accident prevention regulations.

- Observe relevant statutory and accepted regulations during installation, operation, and maintenance of the machine.

### 3.4.2 Qualified personnel

These are people who, by virtue of their training, knowledge and experience as well as their knowledge of relevant regulations can assess the work to be done and recognize the possible dangers involved.

Authorized operators possess the following qualifications:

- are of legal age,
- are familiar with and adhere to the safety instructions and sections of the service manual relevant to operation,
- have received adequate training and authorization to operate electrical and compressed air devices.
- Additional qualifications for compressors with refrigerated dryers:
  - Adequate training and authorization on refrigeration devices.

Authorized installation and maintenance personnel have the following qualifications:

- are of legal age,
  - must have read, are familiar with, and adhere to the safety instructions and sections of the service manual applicable to installation and maintenance,
  - are completely familiar with the safety concepts and regulations of electrical, refrigeration, and compressed air engineering,
  - are able to recognize the possible dangers of electrical, refrigeration, and compressed air devices and take appropriate measures to safeguard persons and property,
  - have received adequate training in and authorization for the safe installation and maintenance of this machine.
  - completely familiar with the safety concepts and regulations concerning refrigeration devices,
  - must be able to recognize the possible dangers of refrigeration devices and take appropriate measures to safeguard persons and property.
- Ensure that operating, installation, and maintenance personnel are qualified and authorized to carry out their tasks.

## 3.5 Dangers

### Basic information

Information concerning the various forms of danger that can arise during machine operation are found here.

Basic safety instructions are found in this service manual at the beginning of each chapter in the section entitled 'Safety'.

Warning instructions are found before a potentially dangerous task.

### 3.5.1 Safely dealing with sources of danger

The following describes the various forms of danger that can occur during machine operation.

#### Electricity

Touching voltage-carrying components can result in electric shocks, burns, or death.

- Allow only qualified and authorized electricians or trained personnel under the supervision of a qualified and authorized electrician to carry out work on electrical equipment according to electrical engineering regulations.
- Before commissioning or re-commissioning the machine, the user must make sure there is adequate protection against electric shock from direct or indirect contact.
- Before starting any work on electrical equipment:  
Switch off and lock out the power supply disconnecting device and verify the absence of voltage.
- Switch off any external power sources.  
These may include devices connected to the floating relay contacts.
- Use fuses corresponding to machine power.
- Check regularly that all electrical connections are tight and in proper condition.

#### **Forces of compression**

Compressed air is contained energy. Uncontrolled release of this energy can cause serious injury or death. The following information concerns work on components that could be under pressure.

- Close shut-off valves or otherwise isolate the machine from the distribution network to ensure that no compressed air can flow back into the machine.
- Depressurize all pressurized components and enclosures.
- Do not carry out welding, heat treatment or mechanical modifications to pressurized components (e.g. pipes and vessels) as this influences the component's resistance to pressure. The safety of the machine is then no longer ensured.

#### **Rotating components**

Touching the fan while the machine is switched on can result in serious injury.

- Do not open the enclosure while the machine is switched on.
- Switch off and lock out the power supply disconnecting device and verify the absence of voltage.
- Wear close-fitting clothes and a hair net if necessary.
- Ensure that all covers and safety guards are in place and secured before restarting.

#### **Temperature**

High temperatures are generated during compression. Touching hot components may cause injuries.

- Avoid contact with hot components.  
These include, for example, the refrigerant condenser.
- Wear protective clothing.
- If welding is carried out on or near the machine take adequate measures to ensure that no parts of the machine can ignite because of sparks or heat.

#### **Operating fluids/materials**

The used operating fluids and materials can cause adverse health effects. Suitable safety measures must be taken in order to prevent injuries.

- Strictly forbid fire, open flame and smoking.
- Follow safety regulations when dealing with refrigerant and chemical substances.
- Avoid contact with skin and eyes.

- Do not inhale refrigerant mist and vapours.
- Do not eat or drink while handling refrigerant.
- Keep suitable fire extinguishing agents ready for use.
- Allow only qualified specialists to work on refrigerant circuits.
- Use only KAESER approved operating materials.

**Noise**

The enclosure absorbs the machine noise to a tolerable level. This function will be effective only if the enclosure is closed.

- Operate the machine only with intact sound insulation.
- Wear hearing protection if necessary.

**Unsuitable spare parts**

Unsuitable spare parts compromise the safety of the machine.

- Use only spare parts approved by the manufacturer for use in this machine.
- Use only genuine KAESER replacement parts on pressure bearing parts.

**Conversion or modification of the machine**

Modifications, additions to and conversions of the machine can result in unpredictable hazards.

- Do not convert or modify the machine!
- Obtain written approval by the manufacturer prior to any technical modification or expansion of the machine, the controller, or the control programs.

**3.5.2 Safe machine operation**

Information on safe conduct when handling the machine is found here.

**Transport**

The weight and size of the machine require safety measures during its transport to prevent accidents.

- Use suitable lifting gear that conforms to local safety regulations.
- Allow transportation only by personnel trained in the safe movement of loads.
- Attach lifting gear only to suitable lifting points.
- Be aware of the center of gravity to avoid tipping.
- Make sure the danger zone is clear of personnel.
- Do not step onto machine components to climb up the machine.

**Installation**

A suitable installation location for the machine prevents accidents, faults, and damage.

- Install the machine in a suitable compressor room.
- Ensure sufficient and suitable lighting such that the display can be read and work carried out comfortably and safely.
- Ensure accessibility so that all work on the machine can be carried out without danger or hindrance.

- If installed outdoors, the machine must be protected from frost, direct sunlight, dust, rain, and splashing water.
- Do not operate in areas in which specific requirements with regard to explosion protection are in force.
- Ensure adequate ventilation.
- Place the machine in such a manner that the working conditions in its environment are not impaired.
- Comply with limit values for ambient temperature and humidity.
- Ensure clean compressed air without damaging components.  
Damaging contaminants are for instance: explosive or chemically instable gases and vapors, acid or base forming substances such as ammonia, chlorine, or hydrogen sulfide.
- Do not position the machine in the warm exhaust air flow from other machines.
- Keep suitable fire extinguishing agents ready for use.

#### **Commissioning, operation, and maintenance**

During commissioning, operation, and maintenance you may be exposed to dangers resulting from, e.g., electricity, pressure, and temperature. Careless actions can cause accidents with severe adverse effects for your health.

- Allow maintenance work to be carried out only by authorized personnel.
- Switch off and lock out the power supply disconnecting (isolating) device and check that no voltage is present.
- Check that the floating relay contacts are voltage-free.
- Close shut-off valves or otherwise isolate the machine from the compressed air network to ensure that no compressed air can flow back into the machine.
- Depressurize all pressurized components and enclosures.
- Allow the machine to cool down.
- Do not open the cabinet while the machine is switched on.
- Do not open or dismantle any valves.
- Use only spare parts approved by KAESER for use in this machine.

#### **Decommissioning, storage, and disposal**

Improper handling of used or old operating fluids and components represent a danger for the environment.

- Drain all fluids from the machine, e.g. refrigerant, and dispose of in accordance with local environmental regulations.
- Do not damage the refrigerant circuit.
- Give refrigerant only to authorized bodies for disposal.
- Dispose of the machine in accordance with local environmental regulations.

### **3.5.3 Organizational Measures**

- Designate personnel and their responsibilities.
- Give clear instructions on reporting faults and damage to the machine.
- Give instructions on fire reporting and fire-fighting measures.

### 3.5.4 Danger Areas

The table gives information on the areas dangerous to personnel.  
 Only authorized personnel may enter these areas.

Activity	Danger area	Authorised personnel
Transport	Within a 10 ft. radius of the machine.	Installation personnel for transport preparation. No personnel during transport.
	Beneath the lifted machine.	No personnel!
Installation	Within the machine.	Installation personnel
	Within 3 ft. radius of the machine and its supply cables.	
Operation	Within a 3 ft. radius of the machine.	Operating personnel
Maintenance	Within the machine.	Maintenance personnel
	Within a 3 ft. radius of the machine.	

Tab. 12 Danger Areas

## 3.6 Safety devices

Various safety devices ensure safe working with the machine.

- Do not change, bypass or disable safety devices.
- Check safety devices for correct function regularly.
- Do not remove or obliterate labels and notices.
- Ensure that labels and notices are clearly legible.

Further information More information on safety devices is contained in chapter 4, section 4.6.

## 3.7 Safety signs

The illustration shows the position of the safety signs on the machine. The table lists the various safety signs used and their meanings.



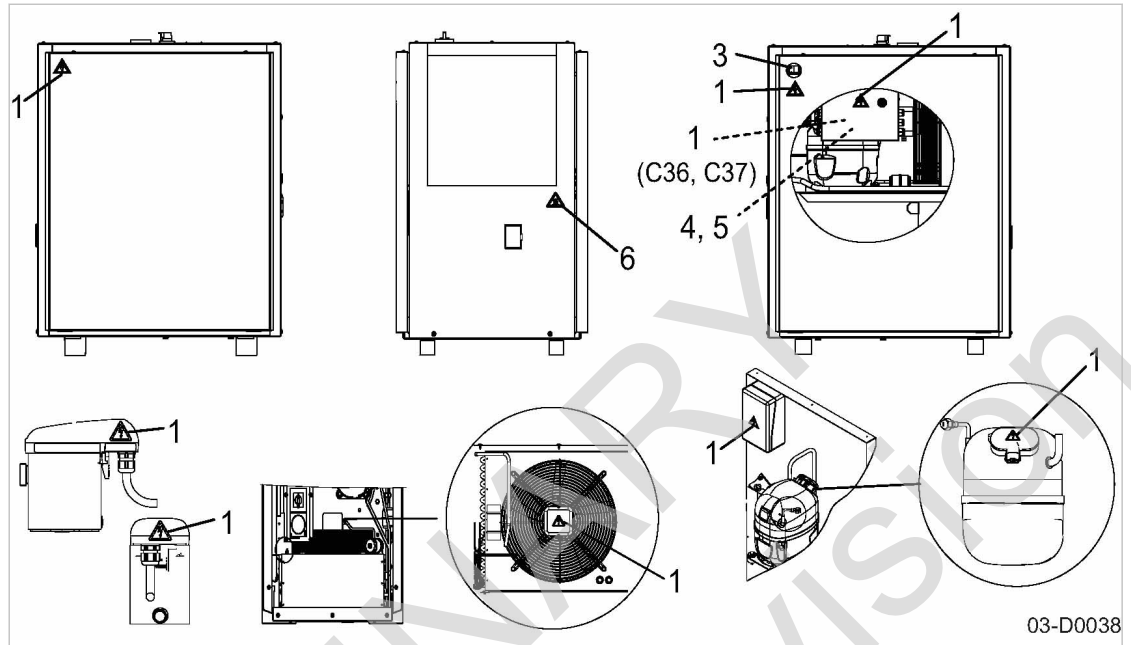

Fig. 1 Location of safety signs

Location	Sign	Meaning
1		Danger of fatal injury from electric shock! <ul style="list-style-type: none"> <li>➤ Before starting any work on electrical equipment: Switch off and lock out the power supply disconnecting device and verify the absence of any voltage.</li> </ul>
3		Personal injury or damage to the machine due to incorrect operation! <ul style="list-style-type: none"> <li>➤ Prior to working on the compressed air system: read and understand the operating instructions and all safety signs.</li> </ul>
4		Risk of electric shock! If the interrupter has tripped current-carrying components of the controller should be examined and replaced if damaged to reduce the risk of fire or electric shock.
5		Risk of electric shock! To maintain overcurrent short-circuit, and ground-fault protection, the manufacturer's instructions for setting the interrupter must be followed to reduce the risk of fire or electric shock.
6		Hot surface can cause serious burns! <ul style="list-style-type: none"> <li>➤ Let the machine cool down.</li> <li>➤ Work carefully.</li> <li>➤ Wear protective clothing and gloves.</li> </ul>

Tab. 13 Safety signs

## 3.8 Emergencies

### 3.8.1 Fire fighting

#### Suitable measures

Calm and prudent action can save lives in the event of a fire.

- Keep calm.
- Give the alarm.
- Shut off supply disconnecting device, if possible.  
Power supply (all poles)  
Cooling water (if available)
- Warn persons in danger.
- Help incapacitated persons.
- Close the doors.
- Try to extinguish the fire if you have the skill to do so.

#### Suitable extinguishing agents

- Suitable extinguishing agents:  
Foam  
Carbon dioxide  
Sand or soil
- Unsuitable extinguishing agents:  
Strong jet of water

### 3.8.2 Injury from Handling Refrigerant

#### Eye contact:

Severe eye irritation, watering, reddening and swelling of the eyelids.  
Risk of caustic burns and frostbite.

- Rinse thoroughly with lukewarm water and seek medical assistance.

#### Skin contact:

Initially a sensation of chill, skin may redden subsequently.  
Risk of frostbite.

- Wash off immediately.
- Treat burns and frostbite appropriately.

#### Inhalation:

At high concentrations, risk of cardiac irregularity (arrhythmia).  
At very high concentration, risk of asphyxia caused by oxygen deficiency.

- Remove the affected person to fresh air and make him or her rest.
- If breathing stops, apply artificial respiration and call for medical assistance.

### 3.9 Warranty

This operator manual contains no independent warranty commitment. Our general terms and conditions of business apply with regard to warranty.

A condition of our warranty is that the machine is used for the purpose for which it is intended under the conditions specified.

Due to the multitude applications for which the machine is suitable the obligation lies with the user to determine its suitability for his specific application.

In addition, we accept no warranty obligation for:

- the use of unsuitable parts or operating materials,
- unauthorized modifications,
- incorrect maintenance,
- incorrect repair.

Correct maintenance and repair includes the use of original spare parts and operating materials.

- Obtain confirmation from KAESER that your specific operating conditions are suitable.

### 3.10 Environment protection

The operation of this machine may cause dangers for the environment.

- Do not allow refrigerants to escape into the environment or the sewage system.
- Store and dispose of operating materials and replaced parts in accordance with local environmental protection regulations.
- Observe national regulations.

This applies in particular to parts contaminated with refrigerant.

## 4 Design and Function

### 4.1 Enclosure

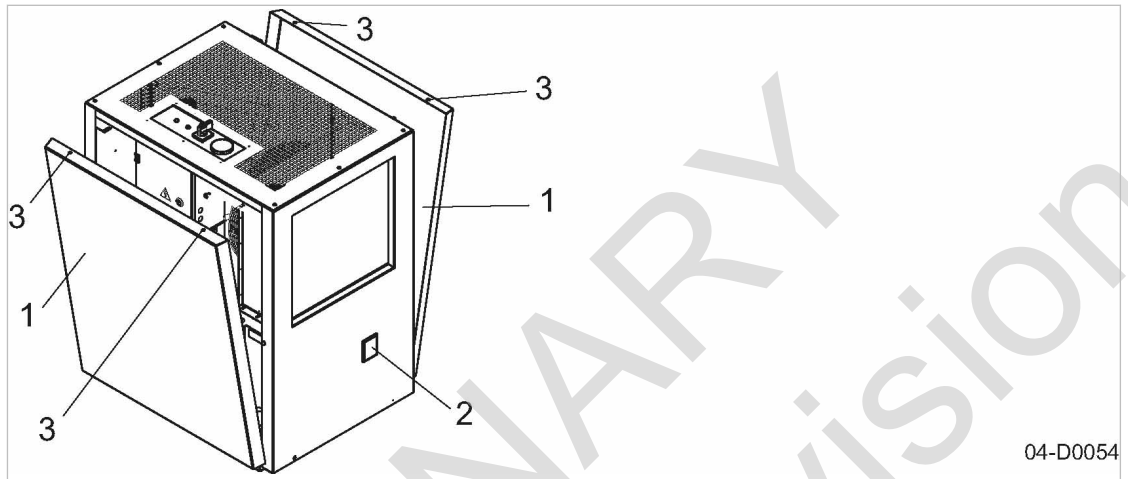

Fig. 2 Enclosure overview

- ① Access panel
- ② Window
- ③ Screw

When closed, the enclosure serves various functions:

- Sound insulation
- Protection against contact with components
- Cooling air flow

The enclosure is not suitable for the following uses:

- Walking, standing, or sitting on the machine.
- As resting place or storage of any kind of load.

Safe and reliable operation is only assured with the enclosure closed.

To open, undo the securing screws and take off panels.

### 4.2 Machine function

The description uses an air-cooled machine as an example.

The refrigerated dryer cools the compressed air. As the compressed air cools, its capacity to retain moisture reduces and the surplus is precipitated out as condensate. This condensate is separated and drained off.

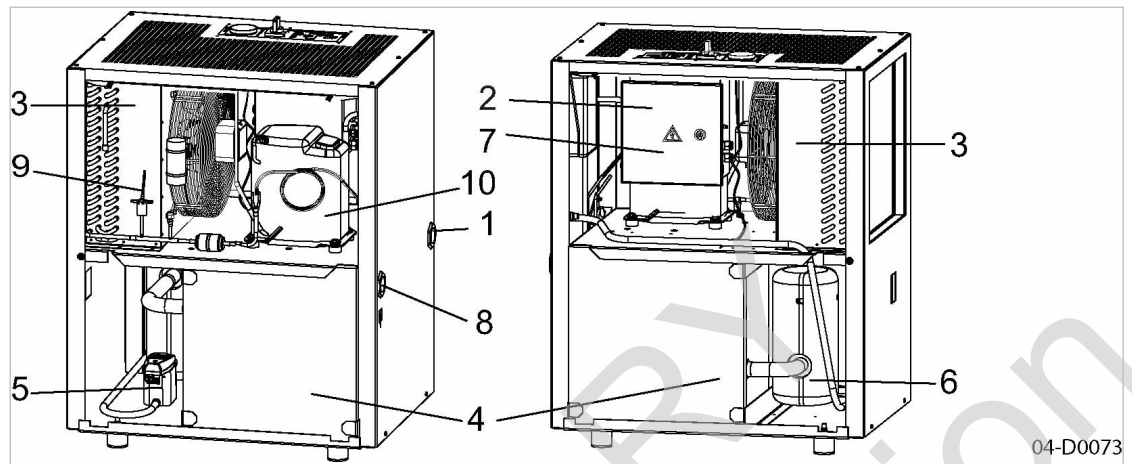

Fig. 3 Machine overview

- |                         |                          |
|-------------------------|--------------------------|
| ① Compressed air inlet  | ⑥ Condensate separator   |
| ② Control cabinet       | ⑦ Temperature regulator  |
| ③ Refrigerant condenser | ⑧ Compressed air outlet  |
| ④ Heat exchanger        | ⑨ Pressure monitor       |
| ⑤ Condensate drain      | ⑩ Refrigerant compressor |

**Stage 1:**

Warm compressed air entering the first section of the heat exchanger gives up some of its heat to the chilled and dried compressed air leaving the dryer.

**Stage 2:**

Further air cooling takes place in the second part of the heat exchanger through which refrigerant flows. The refrigerant gives up its heat to the surroundings in the condenser.

**Stage 3:**

A multi-stage, maintenance-free separation system removes the condensate precipitated out of the compressed air as it is chilled. One or more automatic condensate drains, depending on dryer model, eject the condensate from the separator.

**Stage 4:**

The dry, chilled air takes in some heat from the inflowing warm compressed air in the first part of the heat exchanger through which it passes on the way out of the dryer. The relative humidity of the compressed air has been reduced to about 21%.

### 4.3 SECOTEC CONTROL

SECOTEC CONTROL with cycling control switches the dryer on only when it is needed.

At the heart of the machine is a thermal mass with high specific heat capacity. It is cooled down to cut-out temperature by the refrigerant circuit and extracts the heat from the compressed air flowing through the dryer. When heat extraction raises its temperature to the cut-in point, the refrigerant compressors starts and reduces its temperature once more. The specific heat capacity of the thermal mass ensures that the pressure dew point remains stable long after the refrigerant compressor has stopped on reaching the cut-out temperature.

Consequence:  
Lower power consumption.

#### 4.4 SECOTEC CONTROL switches and indicators

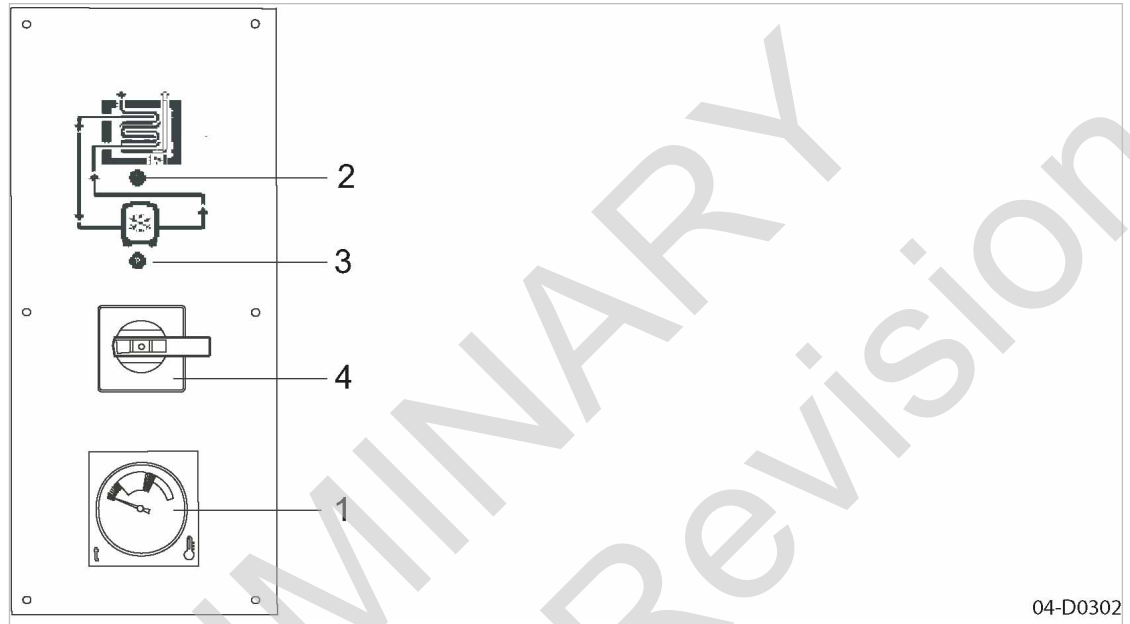

Fig. 4 SECOTEC CONTROL switches and indicators

Item	Name	Function
1	<i>Dew point</i>	Indicates the dryer's operational state.
2	<i>Control voltage ON</i>	Illuminates green with the dryer is provided with power and switched on.
3	<i>Refrigeration compressor ON</i>	Illuminates green as soon as the refrigerant compressor starts.
4	«Main switch»	The machine is switched on and off with the «Main» switch.

Tab. 14 Switches and indicators

##### 4.4.1 Pressure dew point indicator

The pressure dew point indicator provides information on the operating state of the dryer.

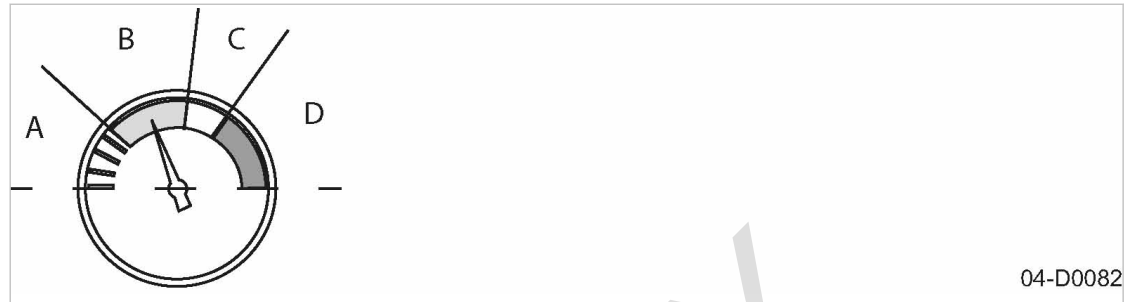

Fig. 5 Pressure dew point indicator

Zone	Color	Meaning
A	Blue	Pressure dew point too low
B	Green	Optimal operating conditions
C	Green/red	Pressure dew point rising
D	Red	Pressure dew point too high (alarm)

Tab. 15 Pressure dew point indicator

Pressure dew point	Consequence
Too low	Condensate can freeze in the heat exchanger.
Normal	Optimum operating conditions reached.
Rising	Optimum air drying no longer achieved.
Too high	Air no longer or insufficiently dried. Downstream pipelines and consumers no longer protected from condensate occurring.

Tab. 16 Pressure dew point and consequences

## 4.5 Electronic condensate drain

Condensate flows into the collecting tank.

A sensor registers the level and signals this to the electronic control.

When the collecting tank is full, a valve opens automatically and drains the condensate.

The valve immediately closes when the condensate drain is empty. No compressed air is lost unnecessarily.

## 4.6 Safety devices

The following safety devices are provided and may not be modified in any way:

- Main switch:  
The main switch also functions as a main disconnect device. In the "0" position, the machine stops immediately.
- Safety pressure limiter:  
The safety pressure limiter shuts down the machine if the pressure of the refrigerant exceeds the permitted maximum. The switch is factory set.

- Temperature regulator:  
The temperature regulator is fitted with a sensor. The red LED on the regulator flashes if a short or broken circuit is detected.  
The LED illuminates continuously if the dew point rises too high.
- Enclosures and covers over moving parts and electrical connections:  
These protect against accidental contact.

## 4.7 Options

The options available for your machine are described below.

### 4.7.1 Option H1 Machine Mountings

These mountings allow the machine to be anchored firmly to the floor.

Details of the fixing holes are contained in the dimensional drawing in chapter 13.1.



Fig. 6 Machine Mountings

- ① Machine mounting
- ② Holes for anchor bolts to fix the mounting to the floor.

### 4.7.2 Option K6 Electronic condensate drain with floating relay contact

A sensor captures the filling level in the condensate drain. Condensate will be drained when the condensate drain is filled. When the condensate drain is empty, the outlet line is closed in a timely manner, to prevent unnecessary pressure drops.

In the event of a fault, the system may forward a message. The floating relay contact switches as soon as the *Fault/Alarm* LED displays a fault.

### 4.7.3 Option C36 Pressure dew point warning

This floating relay contact switches as soon as the pressure dew point exceeds the permissible range. It is automatically reset when the pressure dew point drops back to an acceptable range.

### 4.7.4 Option C37 Floating relay contacts

The "Refrigerated compressor runs" floating relay contact indicates that the refrigerated compressor is in operation.



## 4.8 Accessories

### 4.8.1 Bypass line

The refrigerated dryer can be isolated from the air main with the bypass line. The compressed air supply is maintained, however, no drying takes place.

Further information Further information on installation of a bypass line can be found in chapter 6.8.

### 4.8.2 Transformer

The transformer enables the connection of the machine to different power supply voltages.

Further information The wiring diagram shipped with the transformer contains further details of the power supply connection.

PRELIMINARY  
Subject to Revision

## 5 Installation and Operating Conditions

### 5.1 Ensuring safety

The conditions in which the machine is installed and operated have a decisive effect on safety. Warning instructions are located before a potentially dangerous task.



Disregard of warning instructions can cause serious injuries!

#### Complying with safety warnings

Disregard of safety warnings can cause unforeseeable dangers!

- Strictly forbid fire, open flame, and smoking.
- If welding is carried out on or near the machine take adequate measures to ensure that no parts of the machine can ignite because of sparks or heat.
- Do not store inflammable material in the vicinity of the machine.
- The machine is not explosion-proof!  
Do not operate in areas in which specific requirements with regard to explosion protection are in force.
- Ensure sufficient and suitable lighting such that the display can be read and work carried out comfortably and safely.
- Keep suitable fire extinguishing agents ready for use.
- Ensure that required ambient conditions are maintained.

Required ambient conditions may be:

- Maintain ambient temperature and humidity
- Ensure the appropriate composition of the air within the machine room:
  - clean with no damaging contaminants (e.g., dust, fibers, fine sand)
  - free of explosive or chemically unstable gases or vapors
  - free of acid/alkaline forming substances, particularly ammonia, chlorine or hydrogen sulfide.

### 5.2 Installation conditions

#### 5.2.1 Determining location and clearances

The machine is intended for installation in an appropriate machine room. Information on distances from walls and ventilation is given below.



The distances quoted are recommended distances and ensure unhindered access to all machine parts.

- Please consult an authorized KAESER service representative if you cannot comply with these recommendations.

**Precondition** The floor must be level, firm and capable of bearing the weight of the machine.

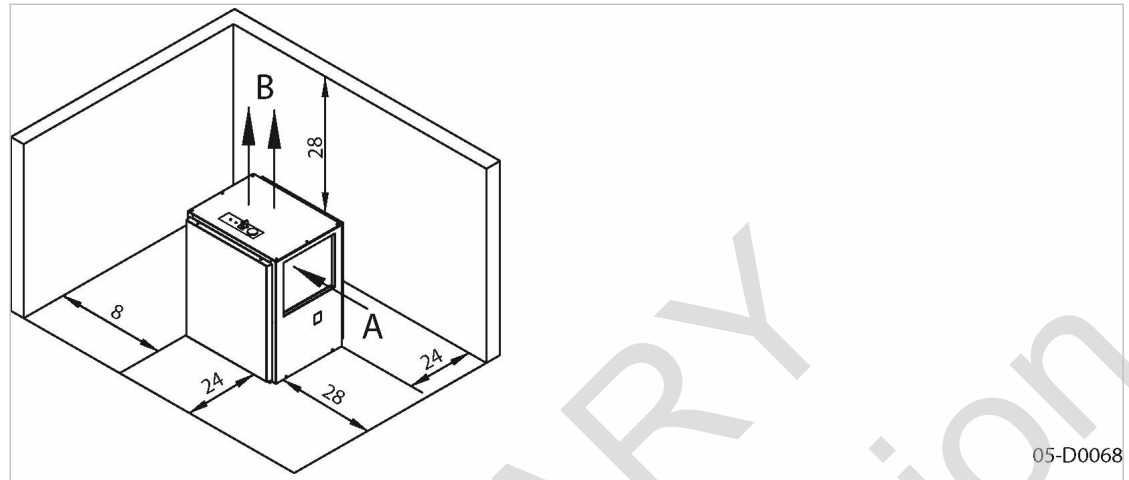

Fig. 7 Recommended machine placement and dimensions [in.]

- (A) Cooling air inlet
- (B) Cooling air outlet

1. **NOTICE** *Ambient temperature too low!*  
*Frozen condensate can damage the machine.*  
➤ *Switch the machine on only when the switch-on temperature is reached.*
2. Consult KAESER for measures where there is danger of frost.
3. Ensure that all intake and exhaust apertures of the enclosure remain opened.
4. Ensure adequate lighting so that all work on the machine can be carried out without danger or hindrance.
5. Ensure that the indicators can be read without glare and that the controller display cannot be damaged by direct sunlight (UV radiation).
6. If installed outdoors, protect the machine against frost, direct sunlight, dust and rain.

### 5.2.2 Ensuring adequate ventilation

Adequate ventilation of the machine room has several tasks:

- It prevents subatmospheric pressure in the machine room.
- It evacuates the exhaust heat of the machine and thus ensures the required operating conditions.



➤ Consult with KAESER if you cannot ensure the conditions for an adequate ventilation of the machine room.

1. Ensure that the volume of air flowing into the machine room is at least equivalent to that being removed from it by the machine and exhaust fan.
2. Keep the inlet and exhaust apertures free of obstructions so that the cooling air can flow freely through the room.
3. Do not install the machine in the exhaust air flow from other machines.
4. Ensure clean air in order to support the proper functioning of the machine.

### 5.2.3 Exhaust duct design

The machine can only overcome the air resistance at the cooling air inlet and exhaust determined by the duct design. Any additional air resistance will reduce airflow and deteriorate machine cooling.

- Consult an authorized KAESER service representative before deciding on:
  - Design of the exhaust air ducting
  - Transition between the machine and the exhaust air duct
  - Length of the ducting
  - Number of duct bends
  - Design of flaps or shutters

## 5.3 Operating the machine in a compressed air network

If the machine is supplying an air network, the system operating pressure may not exceed 232 psig.

Initial charging of a fully vented air system creates a very high rate of airflow through the air treatment devices. These conditions are detrimental to correct air treatment. Air quality suffers.

To ensure the desired air quality when charging a vented air network, we recommend the installation of an air main charging system.

- Consult KAESER for advice on this subject.

## 6 Installation

### 6.1 Ensuring safety

Follow the instructions below for safe installation.

Warning instructions are displayed prior to a potentially dangerous task.



Disregarding warning instructions can cause serious injuries!

#### Basic safety instructions

Ignoring safety instructions can cause unforeseeable dangers!

- Follow the instructions in chapter 3 'Safety and Responsibility'.
- Have the installation carried out only by personnel trained in refrigeration engineering.
- Make sure that no personnel is working on the machine.
- All access doors and panels are closed and secure.

#### Working on live components

Touching voltage carrying components can result in electric shocks, burns or death.

- Work on electrical equipment may only be carried out by authorized electricians.
- Switch off and lock out the power supply disconnecting device and verify the absence of voltage.
- Check that there is no voltage on floating relay contacts.

#### Working on pressure systems

Compressed air is contained energy. Uncontrolled release of this energy can cause serious injury or death. The following safety instructions relate to any work on components that could be under pressure.

- Close shut-off valves or otherwise isolate the machine from the compressed air system to ensure that no compressed air can flow back into the machine.
- Vent all pressurized components and chambers immediately.
- Do not open or dismantle any valves.

#### Working on the drive system

Touching voltage carrying components can result in electric shocks, burns or death.

Touching the fan while the machine is switched on can result in serious injury.

- Switch off and lock out the power supply disconnecting device and verify the absence of voltage.
- Do not open the cabinet while the machine is switched on.

Further information Details of authorized personnel are found in chapter 3.4.2.

Details of dangers and their avoidance are found in chapter 3.5.

## 6.2 Reporting Transport Damage

1. Check the machine for visible and hidden transport damage.
2. Inform the carrier and the manufacturer in writing of any damage without delay.

## 6.3 Making the compressed air connection



Condensate in the compressed air network can damage the pipework:

- Install only corrosion-resistant pipes.
- Use fluoroelastomers as sealing material for seals.
- Note the electro-chemical voltage sequence.
- Consult with KAESER for suitable materials for the compressed air network.

Precondition The compressed air system is vented completely to atmospheric pressure.

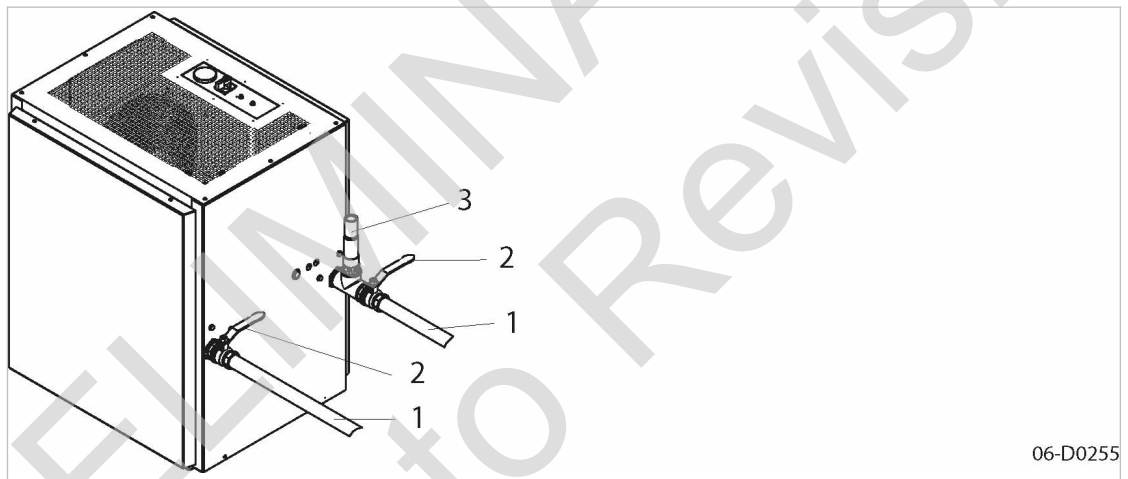

06-D0255

Fig. 8 Compressed air connection

- ① Compressed air line
- ② Shut-off valve
- ③ Safety relief valve (user)

1. **⚠ WARNING** *Serious injury or death can result from loosening or opening components under pressure.*
  - Vent all pressurized components and enclosures.
2. **⚠ NOTICE** *The machine is not protected against air pressure exceeding 232 psi!*
  - The user must install a safety relief valve.
3. **⚠ NOTICE** *An excessive tightening torque may cause the tearing of the connections.*
  - Use a torque wrench to connect the machine to the compressed air network. Do not exceed a tightening torque of 65 Nm.
4. Fit shut-off valves in the compressed air inlet and outlet lines.

Further information The dimensional drawing in chapter 13.1 gives the size and location of the connection ports.

## 6.4 Connecting the condensate drain

A threaded hose connection is provided to attach a condensate drain hose.



The condensate must be able to drain freely.

- Only machines with 232 psig maximum permissible working pressure may be connected to the condensate collecting line.

Fig. 9 shows an installation recommendation.

Condensate flows downward in the collecting line. This prevents condensate flowing back to the machine.

If condensate flows at several points into the condensate collecting line, you must install shut-off valves in the condensate lines to shut the condensate line off before commencing maintenance work.

### Condensate line

Feature	Value
Max. length <sup>1)</sup> [ft]	50
Max. delivery head [ft]	16
Material (pressure-resistant, corrosion-proof)	Copper Stainless steel Plastics Hose line

<sup>1)</sup> For longer lengths, please contact the manufacturer before installation.

Tab. 17 Condensate line

### Condensate collecting line

Feature	Value
Gradient [%]	>1
Max. length <sup>1)</sup> [ft]	65
Material (pressure-resistant, corrosion-proof)	Copper Stainless steel Plastics Hose line

<sup>1)</sup> For longer lengths, please contact KAESER before installation.

Tab. 18 Condensate collecting line

Compressed air flow rate <sup>1)</sup> [cfm]	Line cross-section ["]
<350	3/4
350 – 705	1
706 – 1410	1 1/2

<sup>1)</sup> Compressed air flow rate as guide for the condensate volume to be expected.

Compressed air flow rate <sup>1)</sup> [cfm]	Line cross-section ["]
>1410	2

<sup>1)</sup> Compressed air flow rate as guide for the condensate volume to be expected.

Tab. 19 Condensate collecting line: Line cross-section

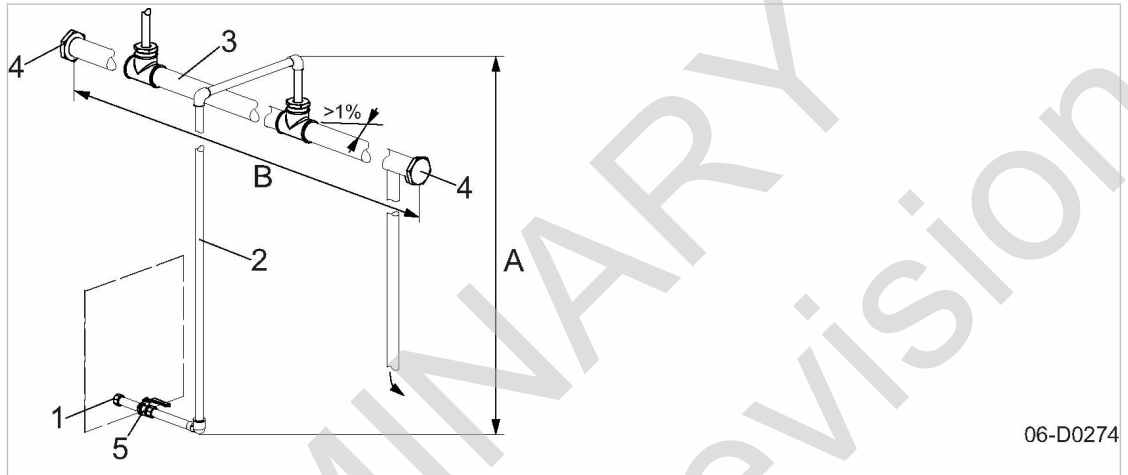

Fig. 9 Connecting the condensate drain

- |                              |  |
|------------------------------|--|
| ① Threaded connection        | ⑤ Shut-off valve                           |
| ② Condensate line            | Ⓐ Delivery head                            |
| ③ Condensate collecting line | Ⓑ Length of the condensate collecting line |
| ④ Screw plug                 |  |

Depending on the machine model, you may have several condensate drains.

- Directly connect every condensate drain to the condensate collecting line.
- Collect the condensate in a suitable container and dispose of in accordance with environmental regulations.



Further information The dimensional drawing in chapter 13.1 provides the size and position of the connection port.

## 6.5 Connecting the machine with the power supply

**Precondition** The power supply disconnecting device is switched off, the device is locked off, the absence of any voltage has been verified.

The tolerance limits of the main voltage (power supply) must be within the permissible tolerance limits of the rated voltage (machine).

1. The power supply must only be connected by authorized installation personnel or an authorized electrician.
2. Carry out safety measures as stipulated in relevant regulations and in national accident prevention regulations. In addition, observe the regulations of the local electricity supplier.
3. Test the overcurrent protection cut-out (backup fuse) to ensure that the time it takes to disconnect in response to a fault is within the permitted limit.
4. Select supply cable conductor cross-sections and fusing in accordance with local regulations.



5. The user must provide the machine with a lockable power supply disconnecting device. This could be, for example, a load disconnect switch with fused input. If a circuit breaker is used it must be suitable for the motor starting characteristics.
6. Check that the tapplings on the control voltage transformer are connected according to the supply voltage.  
If not, change the tapplings to suit the power supply voltage.
7. **▲ DANGER** *Danger of fatal injury from electric shock!*
  - *Switch off and lock out the power supply disconnecting device and check the absence of any voltage.*
8. Connect the machine to the power supply.
9. Ensure that the cabinet again complies with the requirements of degree of protection IP54.

Further information The electrical diagram in chapter 13.3 contains further details for the power supply connection.

## **6.6 Options**

### **6.6.1 Option H1 Anchoring the machine**

- Use appropriate fixing bolts to anchor the machine.

Further information Details of the fixing holes are contained in the dimensional drawing in chapter 13.1.

### **6.7 Option K6 Connecting relay contacts to the condensate drain**

Precondition The power supply disconnecting device is switched off,  
the device is locked off,  
the absence of voltage is verified.

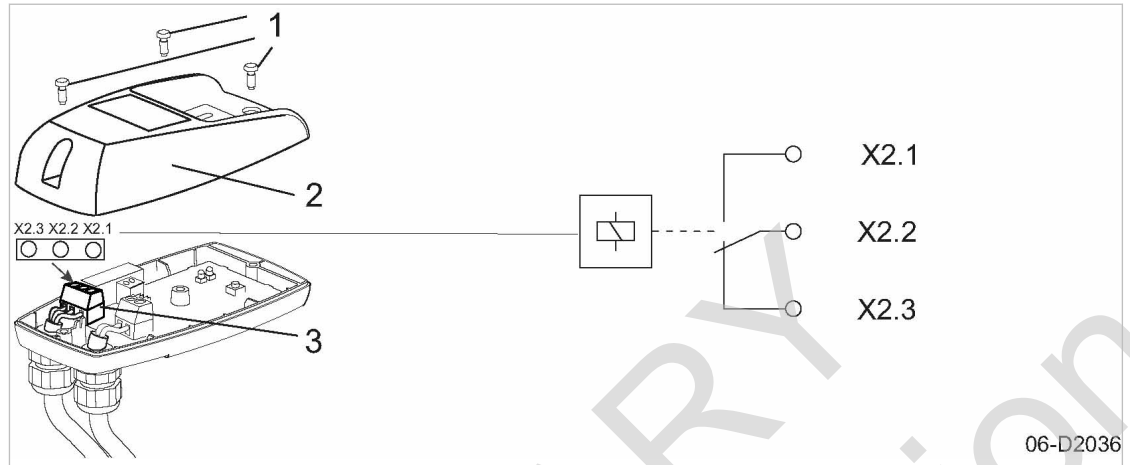

Fig. 10 Option K6: Connecting relay contacts to the condensate drain

- ① Screw
- ② Enclosure top
- ③ Connection for relay contacts

➤ Undo the screw and remove the enclosure top.

Further information Connect the lines for external fault messages to the connection for relay contacts in accordance with the circuit diagram in Chapter 13.3.

### 6.8 Installing a bypass line (accessory)

The bypass line is delivered pre-assembled. The dimensional drawing in chapter 13 includes additional installation information.

1. Install the bypass line on the machine as described below.

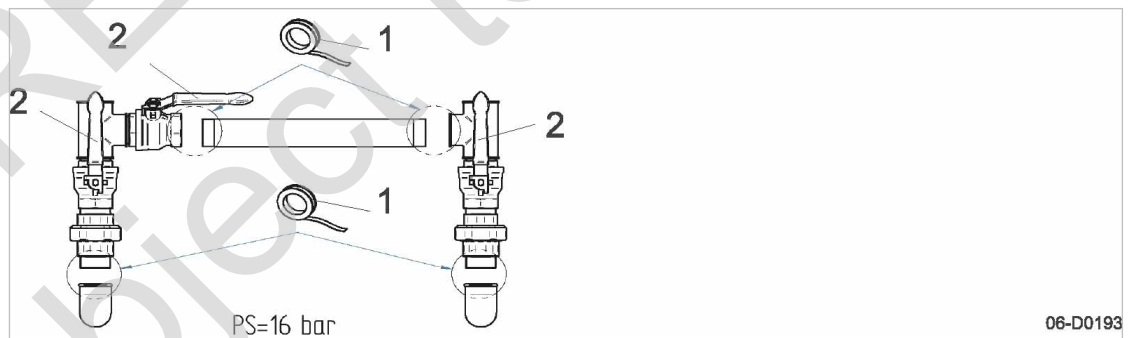

Fig. 11 Bypass line

- ① Sealing tape
- ② Shut-off valve

1. Close the user's shut-off valves.
2. Wrap the screw connections with sealing tape ① and install the bypass line.
3. Check the proper assembly of the bypass line.
4. Close all access doors.
5. Open the user's shut-off valve.
6. Start the machine and check the bypass line fittings for leaks.

## 7 Initial Start-up

### 7.1 Ensuring safety

Instructions for Safe Initial Start-up of the Machine.

Warning instructions are found before a potentially dangerous task.



Disregarding warning instructions can cause serious injuries!

#### Basic safety instructions

- Follow the instructions in chapter 3 'Safety and Responsibility'.
- Have installation work carried out by authorized installation personnel only.
- Make sure that no personnel is working on the machine.
- Ensure that all access doors and panels are closed and secure.

#### Working on live components

Touching voltage carrying components can result in electric shocks, burns or death.

- Work on electrical equipment may only be carried out by authorized electricians.
- Switch off and lock out the power supply disconnecting device and verify the absence of voltage.
- Check that there is no voltage on potential-free contacts.

#### Working on pressure system

Compressed air is contained energy. Uncontrolled release of this energy can cause serious injury or death. The following safety instructions relate to any work on components that could be under pressure.

- Close shut-off valves or otherwise isolate the machine from the compressed air system to ensure that no compressed air can flow back into the machine.
- Vent all pressurized components and chambers immediately.
- Do not open or dismantle any valves.

#### Working on the drive system

Touching voltage carrying components can result in electric shocks, burns or death.

Touching the fan while the machine is switched on can result in serious injury.

- Switch off and lock out the power supply disconnecting device and verify the absence of voltage.
- Do not open the cabinet while the machine is switched on.

Further information Details of authorized personnel are found in chapter 3.4.2.  
Details of dangers and their avoidance are found in chapter 3.5.

### 7.2 Instructions to be observed before commissioning or re-commissioning

Incorrect or improper commissioning can cause injury to persons and damage to the machine.

## 7 Initial Start-up

### 7.3 Checking installation and operating conditions

- Commissioning may only be carried out by authorized installation and service personnel who have been trained on this machine.

#### Special measures for re-commissioning after storage

Storage period or standstill longer than:	Remedy
12 months	<ul style="list-style-type: none"> <li>➤ Check condensate drainage.</li> <li>➤ Check the refrigerant condenser.</li> <li>➤ Check the electrical equipment.</li> <li>➤ Check all pipes, hoses and fittings for leaks and any visible damage. Correct any defects immediately.</li> </ul>
36 months	<ul style="list-style-type: none"> <li>➤ Have the overall technical condition checked by an authorized KAESER service representative.</li> </ul>

Tab. 20 Re-commissioning after storage

### 7.3 Checking installation and operating conditions

- Check and confirm all the items in the checklist before initial start-up of the machine.

To be checked	See chapter	Confirmed?
➤ Are the operators fully conversant with safety regulations?	—	
➤ Have all the positioning conditions been fulfilled?	5	
➤ Are the tolerance limits of the mains voltage (power supply) within the permissible tolerance limits of the nominal voltage (machine)? (see electrical diagrams)	13.3	
➤ Are the power supply cable conductor cross-sections and fuse ratings adequate?	2.9	
➤ Have all electrical connections been checked for tightness?	—	
➤ A safety relief valve installed by the user?	6.3	
➤ Shut-off valve fitted to the compressed air connections?	6.3	
➤ Is the condensate drain connected?	6.4	
➤ Option H1: Is the machine firmly anchored to the floor?	6.6.1	
➤ Are all access doors closed and latched and removable panels in place and secured?	—	

Tab. 21 Installation conditions checklist

### 7.4 Starting the machine for the first time

**Precondition** No personnel are working on the machine.  
 All access doors are closed.  
 All removable panels are in place and secured.

1. Open the shut-off valve to the air network.

2. Switch on the power supply disconnecting device.
3. Switch on the machine.

The refrigerant compressor starts. Compressed air will be cooled as soon as the thermal mass is sufficiently cooled.

4. Watch for any faults occurring in the first hours of operation.

PRELIMINARY  
Subject to Revision

## 8 Operation

### 8.1 Switching on and off

Always use the «main switch» to switch the machine on and off.



Fig. 12 Switching on and off

- ① «Main switch»
- ② LED (green) *Control voltage ON*
- ③ LED (green) *Refrigerant compressor ON*

#### 8.1.1 Switching on

**Precondition** No personnel are working on the machine.  
All access doors and panels are closed and secure.

1. Switch on the machine at the «Main switch» .  
The LED *Control voltage ON* is illuminated.  
The LED *Refrigerant compressor ON* lights as soon as the refrigerant compressor starts.
2. Wait 10–15 minutes, then open the shut-off valve to the compressed air network.



If a power failure occurs, the machine is **not** prevented from starting automatically when power is resumed.  
The machine can automatically restart when power is resumed and when the cut-in temperature is reached in the thermal mass.

#### 8.1.2 Switching off

1. Switch off the machine at the «Main switch» .
2. Close the shut-off valves to the air main.

**Result** The *Control voltage* LED extinguishes. The machine is switched off (all poles) and disconnected from the mains supply.

## 8.2 RESETTING the Machine

If the safety pressure switch has shut down the machine, it can only be restarted when the RESET key is pressed.



Fig. 13 Safety pressure switch

① «RESET»

➤ Press the «RESET» key.

**Result** The machine is ready for operation again and will start as soon as pressure has equalized or operating pressure is reached.

## 9 Fault Recognition and Rectification

### 9.1 Basic instructions

The alarm indications valid for your machine are dependent on the individual equipment.

1. Do not attempt fault rectification measures other than those given in this manual!
2. In all other cases:  
Have the fault rectified by an authorized KAESER service representative.

### 9.2 Faults

Fault	Possible cause	Remedy
Water in the compressed air system	Compressed air inlet and outlet reversed.	Check the compressed air connection.
	The condensate is not draining out of the system.	Check and clean the condensate drain and line. Replace the service unit at the condensate drain.
	The safety pressure switch has shut down the machine.	Check operating conditions. Check the machine. RESET the machine.
High pressure drop	Dryer iced up on the air side.	Switch off the machine and increase the ambient temperature.
	Continuous air loss from the condensate drain.	Check the condensate drain.
Pressure dew point too high	Ambient or compressed air inlet temperature too high.	Check installation conditions are OK.
	Low refrigerant level.	Call an authorized KAESER service representative.
	Dirt collecting in the compressed air system.	Call an authorized KAESER service representative.
The safety pressure switch shuts down the machine	Ambient or compressed air inlet temperature too high.	Check installation conditions are OK.
	Refrigerant condenser dirty.	Clean the refrigerant condenser.

Tab. 22 Faults and remedies



## 10 Maintenance

### 10.1 Ensuring safety

Follow the instructions below to ensure safe machine maintenance.  
Warning instructions are found before a potentially dangerous task.



Disregarding warning instructions can cause serious injuries!

#### Basic safety instructions

Ignoring safety instructions can cause unforeseeable dangers!

- Follow the instructions in chapter 3 'Safety and Responsibility'.
- Maintenance work may only be carried out by authorized personnel.
- Make sure that no personnel is working on the machine.
- Ensure that all access doors and panels are closed and secure.

#### Working on live components

Touching voltage carrying components can result in electric shocks, burns or death.

- Work on electrical equipment may only be carried out by authorized electricians.
- Switch off and lock out the power supply disconnecting device and verify the absence of voltage.
- Check that there is no voltage on potential-free contacts.

#### Working on pressure system

Compressed air is contained energy. Uncontrolled release of this energy can cause serious injury or death. The following safety instructions relate to any work on components that could be under pressure.

- Close shut-off valves or otherwise isolate the machine from the compressed air system to ensure that no compressed air can flow back into the machine.
- Vent all pressurized components and chambers completely.
- Do not open or dismantle any valves.

#### Working on the drive system

Touching voltage carrying components can result in electric shocks, burns or death.  
Touching the fan while the machine is switched on can result in serious injury.

- Switch off and lock out the power supply disconnecting device and verify the absence of voltage.
- Do not open the cabinet while the machine is switched on.

Further information Details of authorized personnel are found in chapter 3.4.2.  
Details of dangers and their avoidance are found in chapter 3.5.

## 10.2 Regular maintenance tasks

The refrigeration circuit is fully hermetically sealed and needs no maintenance. Repairs may only be carried out by certified personnel.

The table below lists the required maintenance tasks.

- Carry out maintenance tasks, or have them carried out, punctually as determined by ambient and operating conditions:

Interval	Maintenance task	See chapter
Weekly	Check the condensate drain.	10.5
Monthly	Clean the refrigerant condenser.	10.4
Quarterly	Check lines, hoses and fittings for leaks.	–
Annually	Check refrigerant circuit for leaks.	–
	Have the pressure control checked by an authorized KAESER service representative.	–
	Check that all electrical connections are tight.	–
Up to 6,000 h, at the latest every 2 years.	Condensate drain: Replace the Service Unit.	10.5.2

Tab. 23 Regular maintenance tasks

## 10.3 Regular service tasks

The table below lists necessary service tasks.

- Have an authorized KAESER service representative carry out service tasks.
- Have service tasks carried out in a timely manner, taking the ambient and operating conditions into account:

Interval	Service task
Up to 36,000 h	Have fan motor (refrigerant condenser) replaced.
up to 36,000 h, at least every six years	Have the plastic pipes and hose lines replaced.
h = operating hours	

Tab. 24 Regular service tasks

## 10.4 Cleaning the refrigerant condenser

Regular cleaning of the refrigerant condenser ensures reliable cooling of the machine and the compressed air. The frequency is mainly dependent on local operating conditions.

**Material** Compressed air for blowing out  
 Brush and cleaning cloths  
 Water with cleaning agent additive



Fig. 14 Cleaning the refrigerant condenser

- ① Refrigerant condenser

**Precondition** The power supply disconnecting device is switched off, the device is locked off, the absence of voltage has been verified.

1. Use compressed air (<6 bar) to blow the refrigerant condenser clean at regular intervals.
2. Use a grease solvent detergent on heavy contamination.

## 10.5 Option K5 / K6 Electronic condensate drain

The condensate is removed by an electronic condensate drain.

If there is a condensate drainage malfunction, the valve opens at intervals (about every 3 seconds) to rectify the fault.



Check the condensate drain regularly and replace the service unit as necessary.

**Precondition** The power supply disconnecting device is switched on.  
Machine is pressurized.  
The *Power/Service* LED is illuminated.

### 10.5.1 Check condensate drain

Dependent on the condensate drain version, the controller is equipped with an additional LED *Alarm*.

**Precondition** The power supply disconnecting device is switched on.  
Machine is pressurized.  
The *Power/Service* LED is illuminated.

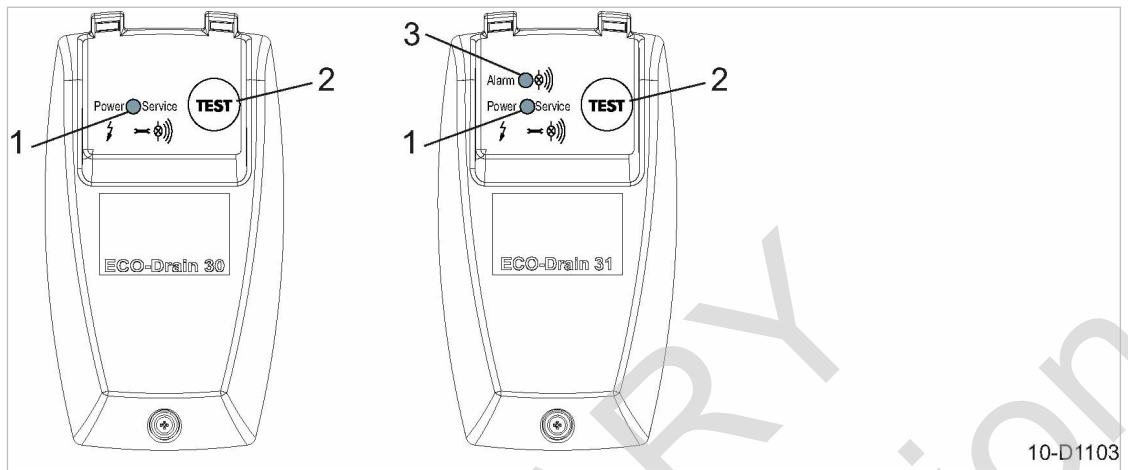

Fig. 15 Check condensate drain

- ① Power/Service LED
- ② «TEST» key
- ③ Alarm LED (Option K6)

1. With one hand, lightly touch the condensate drain hose at the condensate drain.
2. With your other hand, push and hold the «TEST» key at the condensate drain for at least 2 seconds.

**Result** As soon as the condensate drain opens, you will feel a short burst at the condensate drain hose. Replace the service unit if you do **not** experience a burst during manual test.

### 10.5.2 Replace the service unit

The condensate drain cannot be cleaned. The service unit must be changed if condensate does not drain.

**Material** KAESER service unit  
Sealing tape to seal the screw-in part  
As required: O-ring 16x2 (5.1519.0)

**Precondition** The power supply disconnecting device is switched off, the device is locked off, the absence of voltage has been verified.  
The *Power/Service* LED is extinguished.

**⚠ WARNING**

*Danger of fatal injury from electric shock!*

- *Never open the control unit.*

Removing the service unit

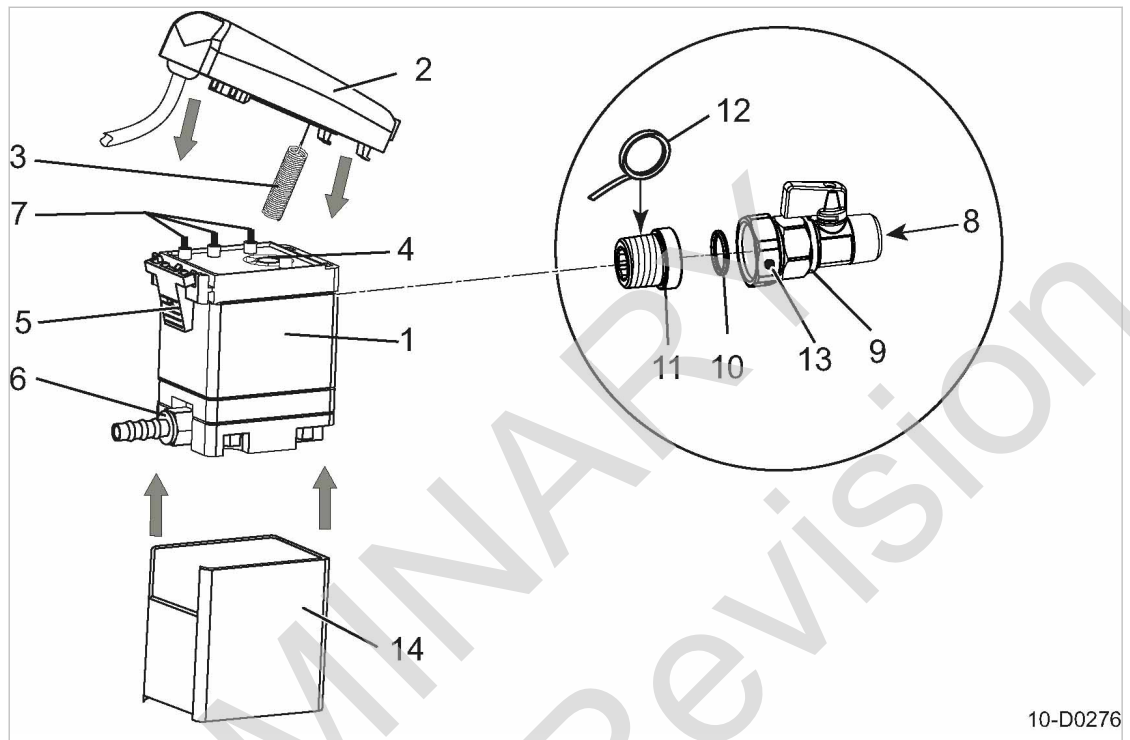

10-D0276

Fig. 16 Option K5/K6: Removing the service unit

- |                                 |                             |
|---------------------------------|-----------------------------|
| ① Service unit                  | ⑧ Condensate inlet          |
| ② Control unit                  | ⑨ Shut-off valve            |
| ③ Sensor                        | ⑩ O-ring                    |
| ④ Sensor opening                | ⑪ Screw-in part             |
| ⑤ Snap fastener                 | ⑫ Sealing tape              |
| ⑥ Condensate drain hose fitting | ⑬ Union nut with vent holes |
| ⑦ Contact springs               | ⑭ Insulation (if provided)  |

1. **⚠ WARNING** *Serious injury or death can result from loosening or opening components under pressure!*
  - *Fully vent all pressurized components and enclosures.*
2. Close the shut-off valve ⑨ upstream of the condensate drain.
3. Unscrew the fitting ⑥ at the condensate line.
4. Press the snap fastener ⑤ and carefully remove the control module ② from the service unit ①.
5. Carefully loosen the union nut ⑬ at the shut-off valve ⑨ until remaining residual air has escaped through the vent holes.
6. Unscrew the screw-in part ⑪ from the service unit ① and place aside.
7. Remove the insulation ⑭ (if available) from the service unit ①.

**Installing the service unit**

Use only KAESER service units to ensure correct function of the condensate drain.

Precondition Ensure that the top of the service unit ① and the contact springs are clean and dry.

1. Fit the insulation ⑭ to the service unit ①.

2. Carefully insert the control module sensor (3) in the opening (2) of the service unit (1).
3. Place the snap fastener (5) of the control module (1) into the service unit eyes.
4. Press the control module (2) against the service unit until the snap fastener audibly clicks into place.
5. At the screw-in part (11), replace old sealing material with new sealing tape.
6. Install the screw-in part (11) in the service unit (1).
7. Tighten the union nut (13) at the shut-off valve (9).
8. Attach the condensate line.
9. Open the shut-off valve (9) upstream of the condensate drain.
10. Close all access doors, replace and secure all removable panels.

PRELIMINARY  
Subject to Revision

## 11 Spares, Operating Materials, Service

### 11.1 Note the nameplate

The nameplate contains all information to identify your machine. This information is essential to us in order to provide you with optimal service.

- Please give the information from the nameplate with every inquiry and order for spares.

### 11.2 Consumable parts and operating materials

KAESER consumable parts and operating materials are all genuine KAESER parts. They are selected for use in KAESER machines.

Unsuitable or poor quality consumable parts and operating fluids/materials may result in damage to the machine or impair its proper function.

Personal injury may result from damage.

#### **⚠ WARNING**

*There is risk of personal injury or damage to the machine resulting from the use of unsuitable spare parts or operating materials.*

- *Use only original KAESER parts and operating materials.*
- *Have an authorized KAESER service representative carry out regular maintenance.*

Name	Number
Service Unit condensate drain	9602

Tab. 25 Consumable parts

### 11.3 KAESER AIR SERVICE

KAESER AIR SERVICE offers:

- authorized KAESER service representatives with KAESER factory training,
  - increased operational reliability ensured by preventive maintenance,
  - energy savings achieved by avoidance of pressure losses,
  - optimum conditions for operation of the compressed air system,
  - the security of genuine KAESER spare parts,
  - increased legal certainty as all regulations are kept to.
- Why not sign a KAESER AIR SERVICE maintenance agreement!

Result Your advantage:  
lower costs and higher compressed air availability.

### 11.4 Replacement parts for service and repair

Use these parts lists to plan your material requirement according to operating conditions and to order the required spare parts.



- Make sure that any service or repair tasks not described in this manual are carried out by an authorized KAESER Service representative.

PRELIMINARY  
Subject to Revision



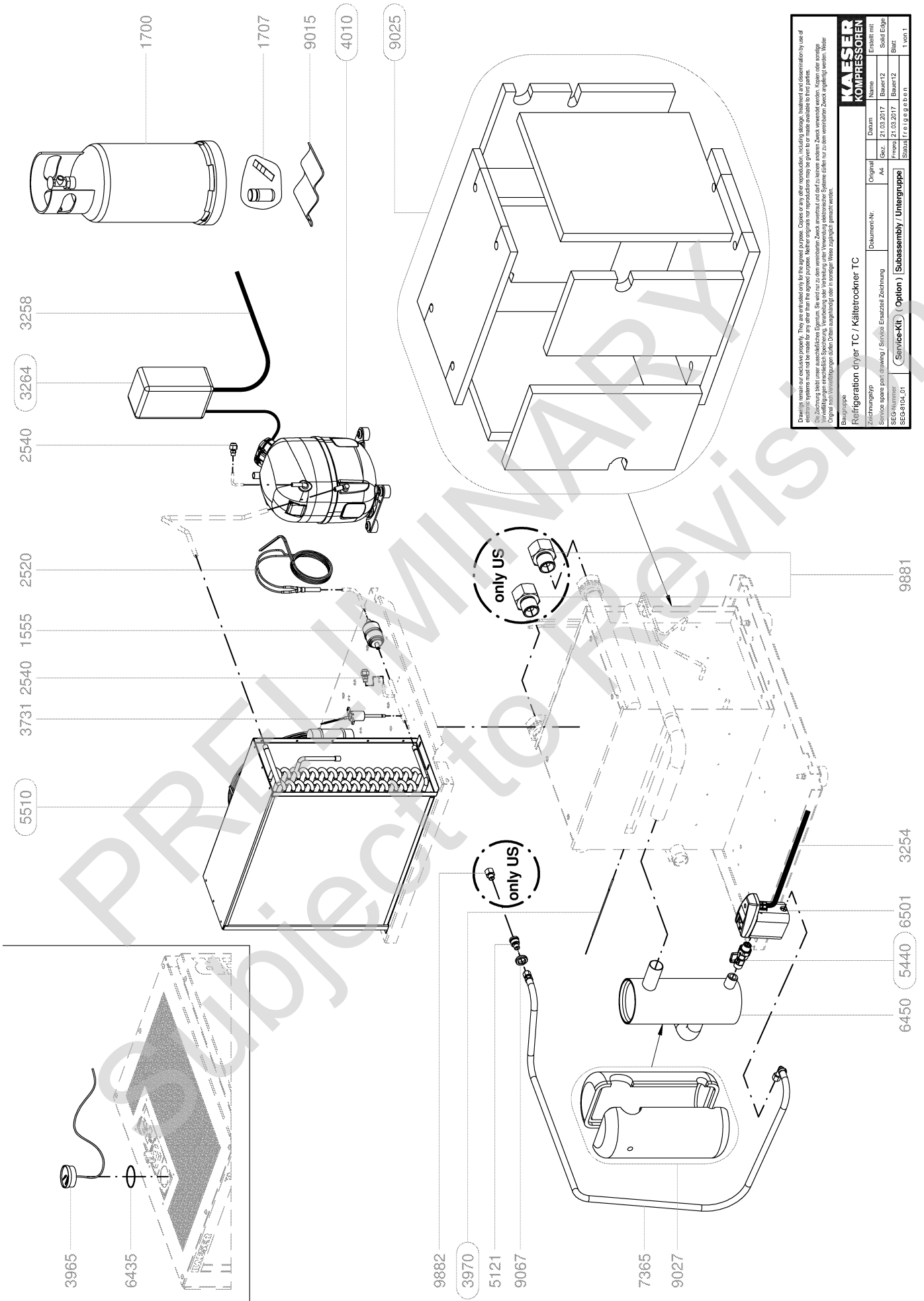

**KAESER KOMPRESSOREN**

Refrigeration dryer TC / Kältetrockner TC

Zeichnungsgruppe	Dokument-Nr.	Original	Datum	Name	Erstellt mit
Service spare part drawing / Service Ersatzteil-Zeichnung			21.03.2017	Bauer12	Solid Edge
SEGA-8104_01			21.03.2017	Bauer12	Blatt
(Service-Kit) / Subassembly / Untergruppe					1 von 1

Bitte beachten Sie die folgenden Hinweise: Dieses Dokument ist ein technisches Dokument und darf nicht kopiert, reproduziert oder in irgendeiner Weise verbreitet werden. Die Zeichnung bleibt unter ausschließlicher Eigentümern. Sie wird nur zu dem vereinbarten Zweck anvertraut und darf zu keinem anderen Zweck verwendet werden. Kopien oder sonstige Vervielfältigungen einschließlich Speicherung, Veränderung oder Verbreitung unter Verletzung unserer Verweigerungs- oder Verweigerungsrechte sind ausdrücklich untersagt. Weitergabe an Dritte ist ausdrücklich untersagt. Die Haftung für Schäden, die aus der Verwendung dieses Dokuments resultieren, ist ausgeschlossen.

Legend		KAESER KOMPRESSOREN
Refrigeration dryer TC		SEL-4222_01 E
Item	Description	Option
1555 *)	Filter dryer	
1700 *)	Refrigerant	
1707	Acid test, refrigerant	
2520 *)	Capillary tube	
2540 *)	Refrigerant filling port	
3254	Condens. drain, connect. cable	
3258	Refr.compress.connecting cable	
3264	Terminal box cpl.	
3731 *)	Safety pressure switch	
3965	Temperature indicator	
3970	Dew point temperature sensor	
4010 *)	Refrigerant compressor	
5121	Double nipple	
5440	Ball valve	
5510 *)	Refrigerant condenser cpl.	
6435	Sealing ring	
6450	Condensate separator	
6501	Condensate drain, dryer	
9602	Condensate drain service-unit	
7365	Condensate drain line	
9015	Insulating tape	
9025	Heat exchanger insulation	
9027	Condens. separator insulation	
9067	Counternut	
9881	Adapter	X
9882	Adapter	X

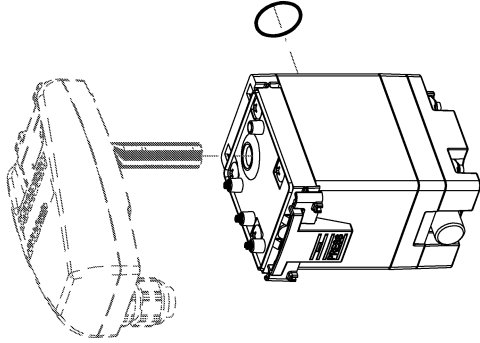

9602

9020

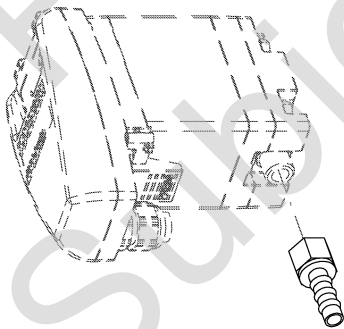
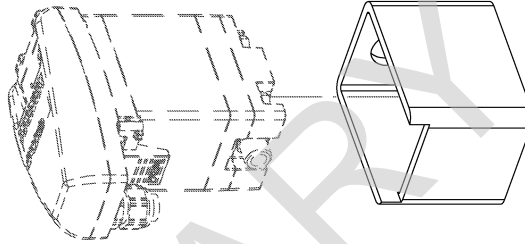

6307

9603

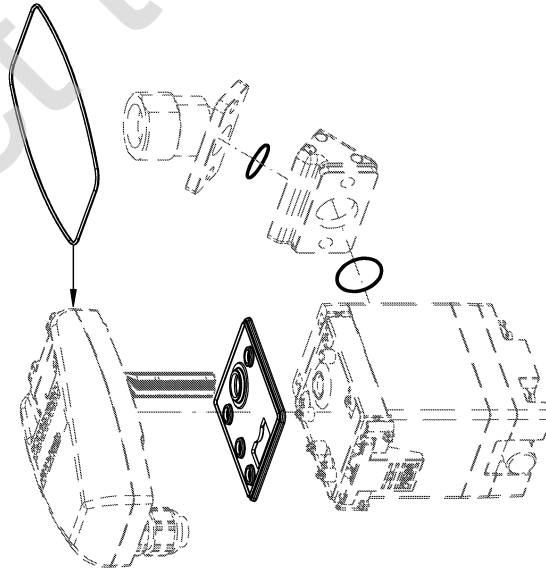

Das Dokument ist ein technisches Dokument. Die hier enthaltenen Zeichnungen, Tabellen, Diagramme, Formeln, Tabellen und Formeln sind ausschließlich für den Einsatz in einem technischen System und sind nicht für andere Zwecke geeignet. Die hier enthaltenen Zeichnungen, Tabellen, Diagramme, Formeln, Tabellen und Formeln sind ausschließlich für den Einsatz in einem technischen System und sind nicht für andere Zwecke geeignet. Die hier enthaltenen Zeichnungen, Tabellen, Diagramme, Formeln, Tabellen und Formeln sind ausschließlich für den Einsatz in einem technischen System und sind nicht für andere Zwecke geeignet.

Kategorie		Original		Erstellt mit	
Zuordnung	Dokument-Nr.	Art	Datum	Blatt	Blatt
Service spare part / Ersatzteil	9602	Blatt 12	13.01.2015	Blatt 12	1 von 1
SEK-Nummer	9602	Blatt 12	13.01.2015	Blatt 12	
SEK-Nummer	9602	Blatt 12	13.01.2015	Blatt 12	
Kategorie		Original		Erstellt mit	
Zuordnung		Dokument-Nr.		Datum	
Service spare part / Ersatzteil		9602		13.01.2015	
SEK-Nummer		9602		13.01.2015	
SEK-Nummer		9602		13.01.2015	
Kategorie		Original		Erstellt mit	
Zuordnung		Dokument-Nr.		Datum	
Service spare part / Ersatzteil		9602		13.01.2015	
SEK-Nummer		9602		13.01.2015	
SEK-Nummer		9602		13.01.2015	

<b>Legend</b>		<b>KAESER</b>															
<b>Condensate drain</b>		SEL-4076_01 E															
<table border="1" style="width: 100%; border-collapse: collapse;"> <thead> <tr> <th style="width: 15%;"><b>Item</b></th> <th style="width: 65%;"><b>Description</b></th> <th style="width: 20%;"><b>Option</b></th> </tr> </thead> <tbody> <tr> <td>6307</td> <td>Hose connection</td> <td></td> </tr> <tr> <td>9020</td> <td>Insulating jacket</td> <td></td> </tr> <tr> <td>9602</td> <td>Condensate drain service-unit</td> <td></td> </tr> <tr> <td>9603</td> <td>Condensate drain gasket kit</td> <td></td> </tr> </tbody> </table>			<b>Item</b>	<b>Description</b>	<b>Option</b>	6307	Hose connection		9020	Insulating jacket		9602	Condensate drain service-unit		9603	Condensate drain gasket kit	
<b>Item</b>	<b>Description</b>	<b>Option</b>															
6307	Hose connection																
9020	Insulating jacket																
9602	Condensate drain service-unit																
9603	Condensate drain gasket kit																
<p>Please quote the part number and serial number of the machine together with the item number and the description of the part when ordering.</p> <p>Before and during all work, be sure to read and follow the safety and service instructions in the machine's service manual!</p>																	

PRELIMINARY  
Subject to Revision

## 12 Decommissioning, Storage and Transport

### 12.1 Decommissioning

This is necessary under the following circumstances:

- The machine is temporarily not needed.
- The machine is to be moved to another location.
- The machine is to be scrapped.

#### Temporarily decommissioning

1. Switch the machine off and is shut-off all connecting lines.
2. Drain condensate from the condensate drain.

#### Permanent decommissioning

Precondition the main disconnecting device is switched off, the switch is locked in the off position, a check has been made that no voltage is present.  
Machine fully vented (no pressure).

1. Drain condensate from the condensate drain.
2. Allow the machine to cool down completely.
3. Drain cooling water from water-cooled machines (option K2).
4. Disconnect all supply lines.

### 12.2 Storage

Moisture can lead to corrosion, particularly on the surfaces of the machine.

Frozen moisture can damage components such as diaphragms, valves, and gaskets.



Please consult with KAESER if you have questions about appropriate storage and commissioning.

Precondition Condensate drain and condensate lines are completely empty.

1. **NOTICE** *Moisture and frost can damage the machine!*
  - *Prevent ingress of moisture and formation of condensation.*
  - *Maintain a storage temperature of >32°F.*
2. Store the machine in a dry, frost-proof room.

### 12.3 Transport

#### 12.3.1 Safety

Weight and center of gravity determine the most suitable method of transportation. The center of gravity is shown in the drawing in chapter 13.1.



- Please consult with KAESER if you intend to transport the machine in freezing temperatures.

**Precondition** Transport only by forklift truck or suitable lifting gear and only by personnel trained in the safe transportation of loads.

- Ensure the danger area is clear of personnel.

### 12.3.2 Transport with a forklift truck

**Precondition** The forks are fully under the machine.

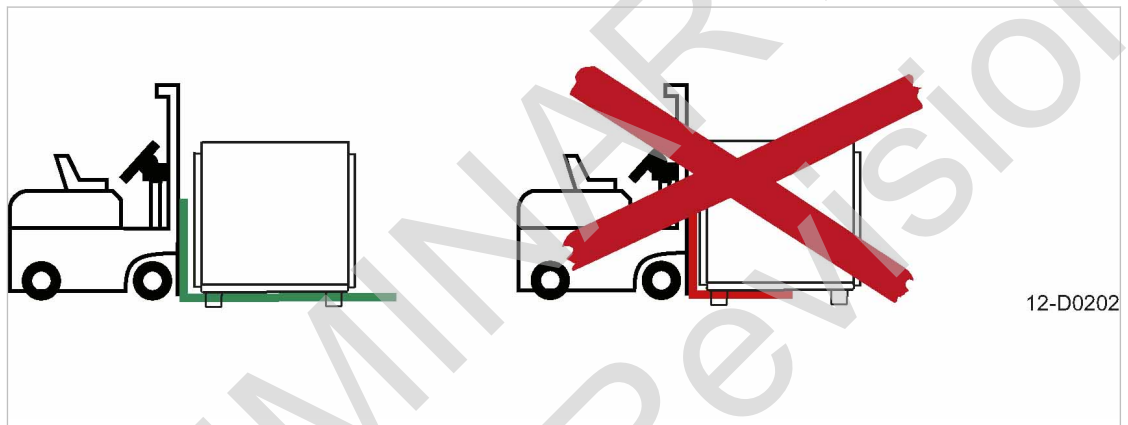

Fig. 17 Transporting with a forklift truck

1. Take note of the center of gravity.
2. Drive the forks completely under the machine or pallet and lift carefully.

### 12.3.3 Transport with a crane

Only suitable and approved load-carrying and attachment devices ensure proper transport of the machine with a crane. Suitable crossbeams ensure sufficient distance of the attachment resources from the machine housing to prevent damage.

The machine is not equipped with fixing points.

Examples of unsuitable fixing points:

- Pipe sockets
- Flanges
- Attached components such as condensate drains.



- Consult KAESER if you require suitable load-carrying and attachment devices or have questions regarding the correct use.

**Precondition** Load-carrying and attachment devices meet the local safety regulations.

The crane, load-carrying and attachment devices or the lifted machine do not endanger personnel.

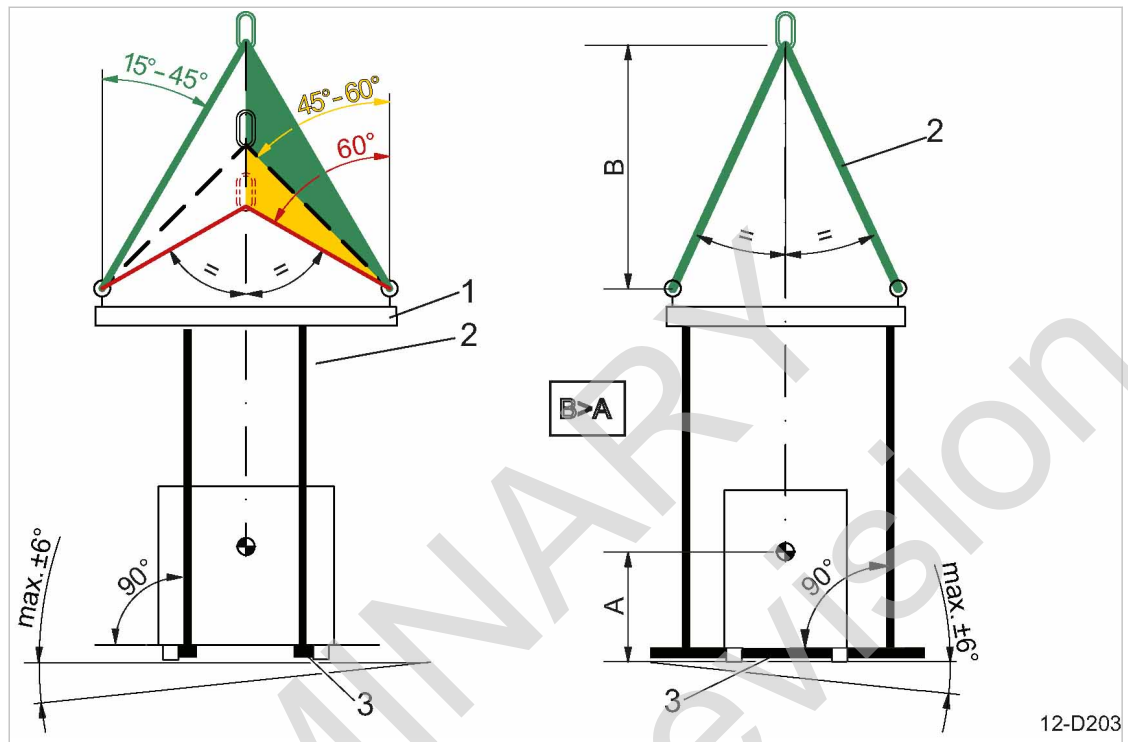

Fig. 18 Transport with a crane

- ① Load carrying devices
- ② Attachment resources

1. **⚠ WARNING** Risk of accident caused by incorrect use of lifting gear and attachment devices!
  - Comply with permissible load limits.
  - Comply with specific safety information of used load-carrying and attachment devices.
2. Properly use load-carrying and attachment devices:
  - Ensure proper distribution of the fastening points relative to the centre of gravity position (symmetrical load distribution).
  - Ensure equal slope angles of 15° to 45° for attachment devices with multiple strands.
    - Slope angles between 45° and 60° may be unsuitable.
    - Slope angles larger than 60° are prohibited.
  - Ensure the maximum incline of 6° of the machine to the horizontal.
  - Ensure sufficient distance of the attachment devices to the machine.
  - Ensure a positive stability height: Dimension B > Dimension A
  - Do not attach the attachment devices to any machine component.
3. Carry out a lifting test:  
Slightly lift the machine to check whether machine remains in horizontal position and does not teeter.
4. Transport the machine only after a successful lifting test.

## 12.4 Disposal

The sealed refrigerant circuit still contains both refrigerant and oil.

1. De-commission the machine.
2. Hand the machine over to an authorized disposal expert.



- Refrigerant and oil must be drained and disposed of by an authorized body.

PRELIMINARY  
Subject to Revision



## 13 Annex

### 13.1 Dimensional drawing

PRELIMINARY  
Subject to Revision

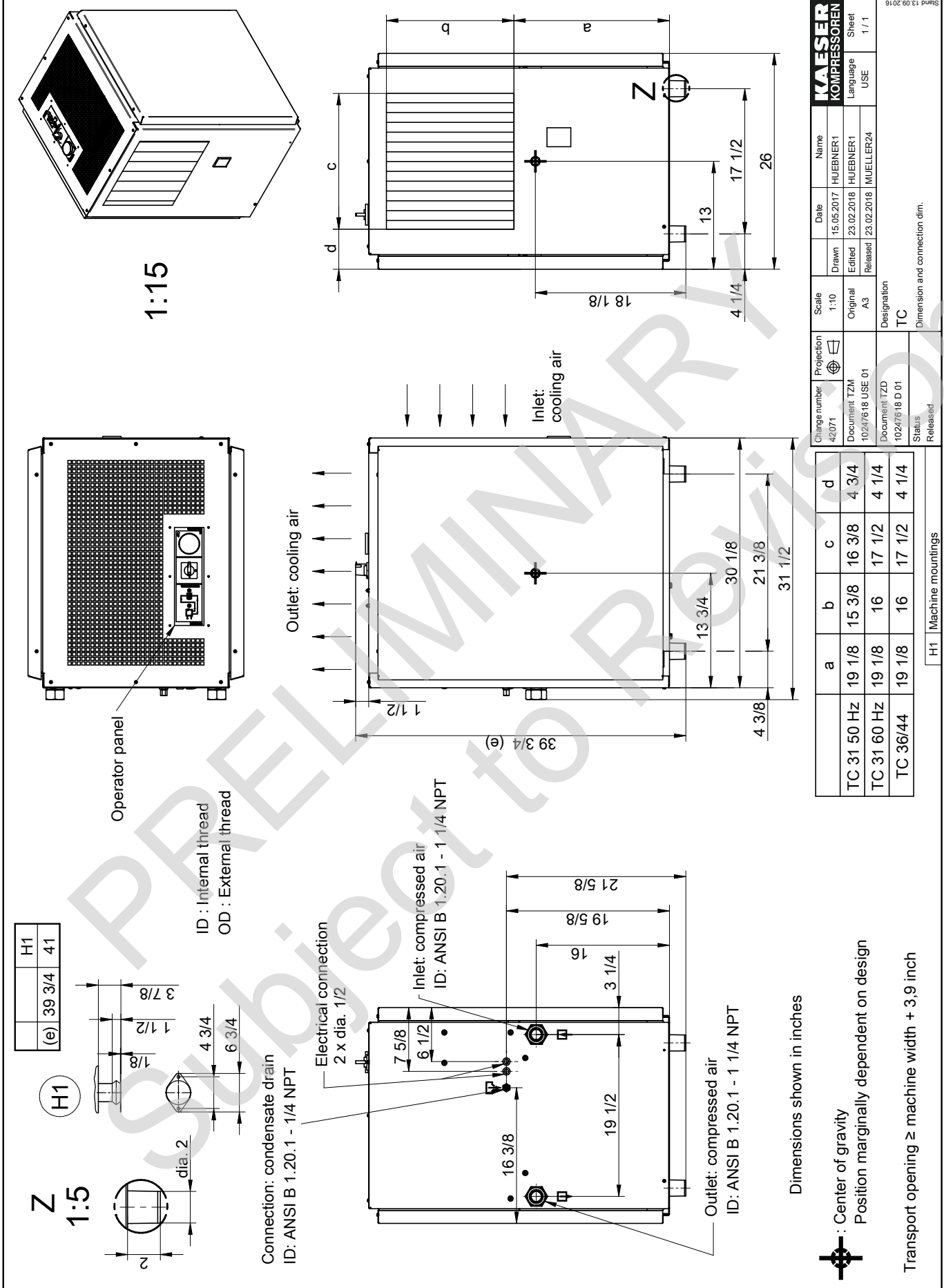

Change number		Projection	Scale	Date	Name
42071		TZM	1:10	15.05.2017	HUEBNER1
Document TZM			Original	23.02.2018	HUEBNER1
10247618 USE 01			A3	23.02.2018	MUELLER24
Document TZD			Designation		
10247618 D 01			TC		
Status	Dimension and connection dim.				
Released					

	a	b	c	d
TC 31 50 Hz	19 1/8	15 3/8	16 3/8	4 3/4
TC 31 60 Hz	19 1/8	16	17 1/2	4 1/4
TC 36/44	19 1/8	16	17 1/2	4 1/4

**Dimensions shown in inches**

**Center of gravity**  
Position marginally dependent on design

**Transport opening ≥ machine width + 3,9 inch**

Drawings remain our exclusive property. Neither originals nor reproductions may be given to or made available to third parties. Copies or other reproductions, including storage, treatment and distribution by use of electronic systems is not allowed for any other than the agreed upon purpose. Subject to development-related changes. Drawing may be altered only via CAD.

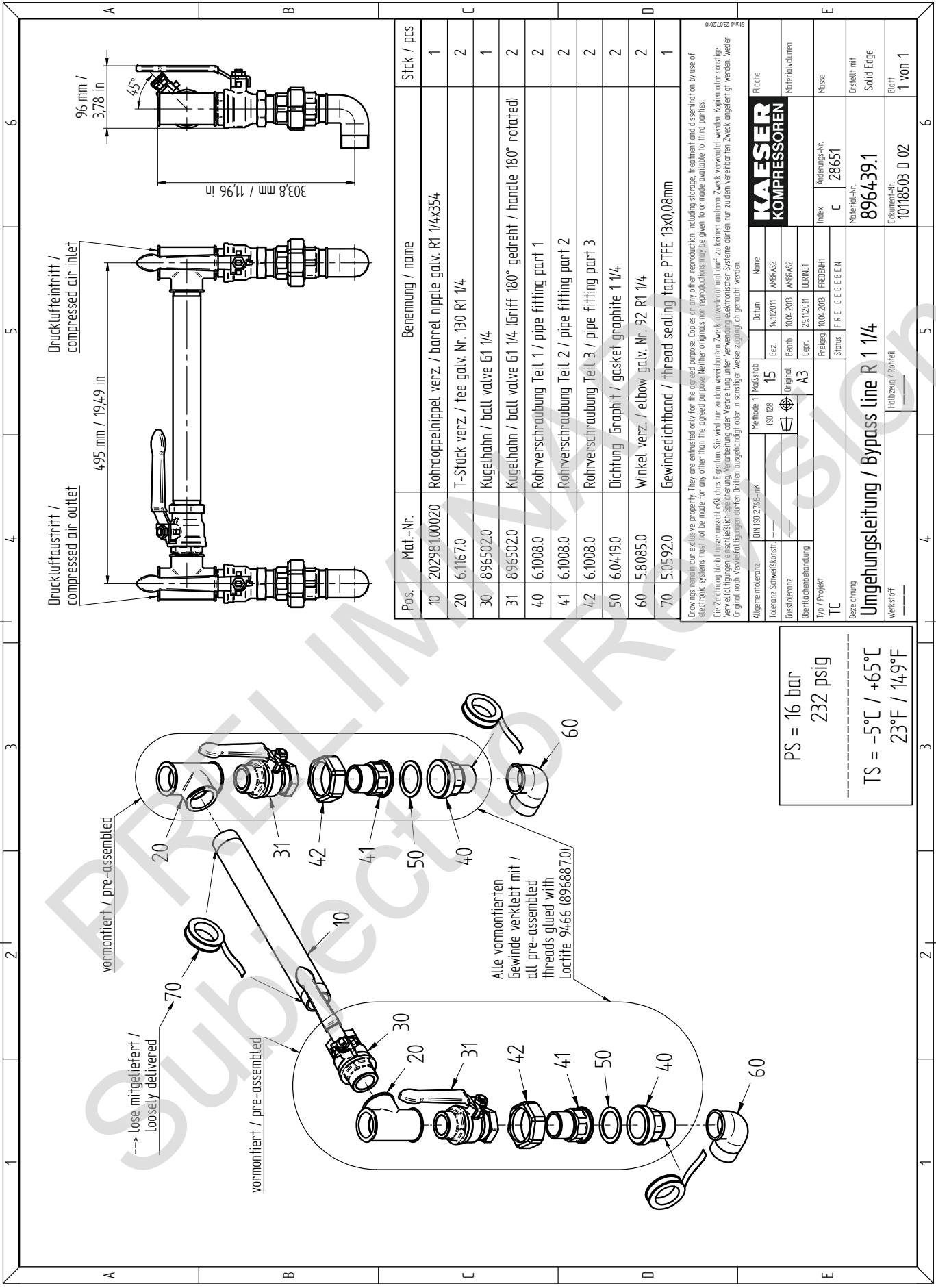

Pos.	Mat.-Nr.	Benennung / name	Stück / pcs
10	20298100020	Rohrdoppelnippel verz. / barrel nipple galv. R1 1/4x354	1
20	6.11670	T-Stück verz. / tee galv. Nr. 130 R1 1/4	2
30	8965020	Kugelhahn / ball valve G1 1/4	1
31	8965020	Kugelhahn / ball valve G1 1/4 (Griff 180° gedreht / handle 180° rotated)	2
40	6.10080	Rohrverschraubung Teil 1 / pipe fitting part 1	2
41	6.10080	Rohrverschraubung Teil 2 / pipe fitting part 2	2
42	6.10080	Rohrverschraubung Teil 3 / pipe fitting part 3	2
50	6.04190	Dichtung Graphit / gasket graphite 1 1/4	2
60	5.80850	Winkel verz. / elbow galv. Nr. 92 R1 1/4	2
70	5.05920	Gewindedichtband / thread sealing tape PTFE 13x0,08mm	1

Drawings and/or electronic property. They are intended only for the original purpose. Copies or any other reproduction, including storage, treatment and dissemination by use of electronic systems may not be made for any other than the original purpose. Neither original nor reproductions may be given to or made available to third parties. Die Zeichnung bleibt unser ausschließliches Eigentum. Sie wird nur zu dem vereinbarten Zweck übermittelt und darf zu keinem anderen Zweck verwendet werden. Kopien oder sonstige Vervielfältigungen (Steuerung, Verarbeitung oder Verbreitung unter Verwendung elektronischer Systeme dürfen nur zu dem vereinbarten Zweck angefertigt werden. Weiter Original nach Vervielfältigungen dürfen Dritten ausgenommen in sonstiger Weise zugänglich gemacht werden.

Algemeinbezeichnung	DIN ISO 2768-mK	Methode	1 Maßstab	Datum	Name	Fläche
Toleranz Schweißkonstr.	ISO 228	ISO 228	15	14.11.2011	AV88452	KAESER KOMPRESSOREN
Übersichtsz.	☐	☐	☐ Digital	Bezt.	1004-2018	AV88452
Oberflächenbehandlung			A3	Bepr.	23112011	LEBRN1
Typ / Projekt	TC	Freigeleg.	1004-2018	Freigeleg.	23112011	LEBRN1
Rezeichnung		Status	FR E I G E L E B E N			
Umgehungleitung / Bypass line R 1/4		Material-Nr.	896439.1			
Werkstoff		Dokument-Nr.	10118503 D 02			
		Halbzug / Rohzeit				

PS = 16 bar  
232 psig

TS = -5°C / +65°C  
23°F / 149°F

## 13.2 Pipeline and instrument flow diagram (P+I diagram)

PRELIMINARY  
Subject to Revision

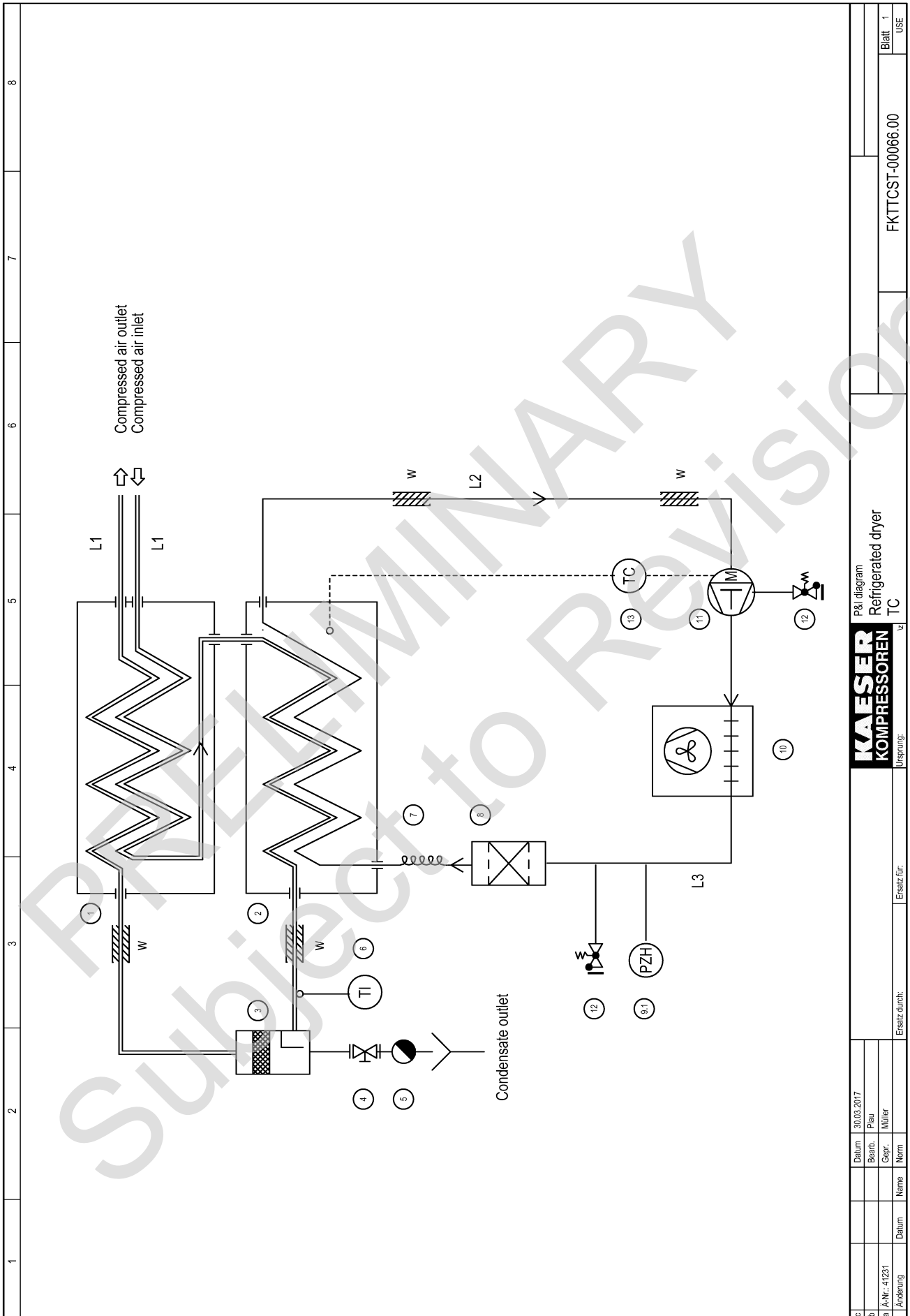

Date		30.05.2017	
Prepared by		Plau	
Checked by		Müller	
Name		Norm	
Date		Ersatz durch:	
Change		Ersatz für:	
<b>KAESER</b> KOMPRESSOREN			
P&I diagram Refrigerated dryer TC			
FKTTCST-00066.00		Blatt 1	
FKTTCST-00066.00		USE	



### 13.3 Electrical Diagram

PRELIMINARY  
Subject to Revision

1	2	3	4	5	6	7	8	
<div style="border: 1px solid black; padding: 10px; margin: 0 auto; width: 80%;"> <p style="text-align: center;"><b>Wiring Diagram</b></p> <p style="text-align: center;"><b>refrigeration dryer TA 5 - TC 44</b></p> <p><b>Power supply:</b></p> <p style="padding-left: 20px;">230V ±10% 1ph 60Hz,</p> <p style="padding-left: 20px;">Single phase system with solidly grounded midpoint of phase</p> <p style="padding-left: 20px;">115V ±10% 1ph 60Hz,</p> <p style="padding-left: 20px;">Single phase system with solidly grounded end of phase</p> </div>								
<p><b>manufacturer:</b> KAESER COMPRESSORS 96450 COBURG GERMANY</p>								
<p><b>ATTENTION !!!</b></p> <p>The document gives collective information on power supply voltages and frequencies for all machines. The voltage and frequency and local conditions under which any particular machine may be used are given on the nameplate of the machine and in the accompanying service manual.</p>								
<p>The drawings remain our exclusive property. They are entrusted only for the agreed purpose. Copies or any other reproductions, including storage, treatment and dissemination by use of electronic systems must not be made for any other than the agreed purpose. Neither originals nor reproductions must be forwarded or otherwise made accessible to third parties.</p>								
c	Datum	07.07.2015	USE	cover page				=
b	Bearbeiter	Stiller	refrigeration dryer TA 5 - TC 44				+	1
a	Geprüft	Gegner	DTR-U3005.00				1	Bl.
A. Abw. durch:	Datum	Name	Norm	Ersatz für:				1
				Ursprung:				1

PRELIMINARY  
Subject to Revision



Lfd. Nr. No.	Benennung Name	Zeichnungsnummer (Kunde) Drawing No. (customer)	Zeichnungsnummer (Hersteller) Drawing No. (manufacturer)	Blatt Page	Anlagenkennzeichen Unit designation
1	cover page		DTR-U3005.00	1	
2	list of contents		ZTR-U3005.00	1	
3	wiring diagram		UTR-U3005.00	1	
4	electrical component parts list	general instructions	UTR-U3005.00	2	
5	electrical component parts list	performance-related components	UTR-U3005.00	3	
6	electrical component parts list	performance-related components	UTR-U3005.00	4	
7	wiring diagram	power unit	STR-U3005.00	1	
8	wiring diagram	control unit	STR-U3005.00	2	
9	wiring diagram	volt-free contacts	STR-U3005.00	3	
10	terminal connection	terminal strip -X1 / 115V	KTR-U3005.00	1	
11	terminal connection	terminal strip -X1 / 230V	KTR-U3005.00	2	
12	wiring diagram	control panel	ATR-U3005.00	1	

c	Datum	07.07.2015	list of contents	=	
b	Bearbeiter	Stiller	refrigeration dryer TA 5 - TC 44	+	
a	Geprüft	Gegner			
B	Abw. durch:	Ersatz für:			ZTR-U3005.00
	Datum	Name	Ursprung:		page 1
					1 Bl.

1	2	3	4	5	6	7	8																												
<p><b>general instructions</b></p> <p><b>ATTENTION !!!</b> Install supplies, grounding and shock protection to local safety regulations.</p> <p>control cabinet wiring for non-designated conductors with multi-standard stranded conductors          primary circuits: black 2,5mm<sup>2</sup> H07V-K, 14AWG UL-Style 1015, CSA-TEW          primary circuits grounded: grey 2,5mm<sup>2</sup> H07V-K, 14AWG UL-Style 1015, CSA-TEW          control voltage AC: red 1mm<sup>2</sup> H05V-K, 18AWG UL-Style 1015, CSA-TEW          control voltage AC grounded: white 1mm<sup>2</sup> H05V-K, 18AWG UL-Style 1015, CSA-TEW          external voltage: orange 1,5mm<sup>2</sup> H07V-K, 16AWG UL-Style 1015, CSA-TEW          ground conductor: green/yellow 2,5mm<sup>2</sup> H07V-K, 14AWG UL-Style 1015, CSA-TEW</p> <hr style="border-top: 1px dashed black;"/> <p>option C36 = warning pressure dew point          option C37 = Refrigerant compressor running          option K5 = condensate drain          option K6 = condensate drain, volt-free contact</p> <hr style="border-top: 1px dashed black;"/> <table style="width: 100%; border-collapse: collapse;"> <tr> <td style="width: 15%; vertical-align: top;">-B30</td> <td style="width: 45%;">safety air pressure switch ( Pressure cut out)</td> <td style="width: 20%; vertical-align: top;">-M30</td> <td style="width: 20%;">Refrigerant compressor with overload protection</td> </tr> <tr> <td style="vertical-align: top;">-B35</td> <td>NTC-temperature probe</td> <td style="vertical-align: top;">-M31</td> <td>vent motor with overload protection</td> </tr> <tr> <td style="vertical-align: top;">-B37</td> <td>NTC-thermostat</td> <td style="vertical-align: top;">-P30/-P31</td> <td>LED indicator</td> </tr> <tr> <td style="vertical-align: top;">-1FU/-2FU</td> <td>primary control fuse</td> <td style="vertical-align: top;">-Q0</td> <td>manual motor controller</td> </tr> <tr> <td style="vertical-align: top;">-3FU/-4FU</td> <td>fuses vent motor</td> <td style="vertical-align: top;">-Q30</td> <td>motor starter</td> </tr> <tr> <td style="vertical-align: top;">-5FU</td> <td>secondary control fuse / fuse control voltage</td> <td style="vertical-align: top;">-T31</td> <td>control transformer</td> </tr> <tr> <td style="vertical-align: top;">-K33</td> <td>automatic condensate drain</td> <td style="vertical-align: top;">-X1</td> <td>terminal strip</td> </tr> </table>								-B30	safety air pressure switch ( Pressure cut out)	-M30	Refrigerant compressor with overload protection	-B35	NTC-temperature probe	-M31	vent motor with overload protection	-B37	NTC-thermostat	-P30/-P31	LED indicator	-1FU/-2FU	primary control fuse	-Q0	manual motor controller	-3FU/-4FU	fuses vent motor	-Q30	motor starter	-5FU	secondary control fuse / fuse control voltage	-T31	control transformer	-K33	automatic condensate drain	-X1	terminal strip
-B30	safety air pressure switch ( Pressure cut out)	-M30	Refrigerant compressor with overload protection																																
-B35	NTC-temperature probe	-M31	vent motor with overload protection																																
-B37	NTC-thermostat	-P30/-P31	LED indicator																																
-1FU/-2FU	primary control fuse	-Q0	manual motor controller																																
-3FU/-4FU	fuses vent motor	-Q30	motor starter																																
-5FU	secondary control fuse / fuse control voltage	-T31	control transformer																																
-K33	automatic condensate drain	-X1	terminal strip																																
c	Datum			wiring diagram																															
b	Bearbeiter			refrigeration dryer TA 5 - TC 44																															
a	Geprüft			general instructions	page	1																													
C	Datum	Name	Ersatz durch:	Ursprung:	4	Bl.																													
	07.07.2015	Siller	Ersatz für:	UTR-U3005.00	=																														
	Geprüft	Gegner	Ersatz durch:	UTR-U3005.00	+																														

model	model-dependent components				=	+	-	page 2	4. Bl.																		
	TA5	TA8	TA11	TB19																							
machine power supply	115 V ±10 %, 60 Hz	115 V ±10 %, 60 Hz	115 V ±10 %, 60 Hz	115 V ±10 %, 60 Hz																							
manual motor controller -Q0 Sontheimer	896595.00020 HLT40/3ZM/Z20	896595.00020 HLT40/3ZM/Z20	896595.00020 HLT40/3ZM/Z20	896595.00020 HLT40/3ZM/Z20																							
contactor -Q30 Siemens	7.8740.00310 3RT2016-1AK61	7.8740.00310 3RT2016-1AK61	7.8740.00310 3RT2016-1AK61	7.8740.00320 3RT2017-1AK61																							
fuse socket -3FU Wöhner	7.3320.00050 Class CC 1-pol.	7.3320.00050 Class CC 1-pol.	7.3320.00050 Class CC 1-pol.	7.3320.00050 Class CC 1-pol.																							
fuse -3FU Gould	7.3305.00010 ATDR 2,5 A	7.3305.00010 ATDR 2,5 A	7.3305.00010 ATDR 2,5 A	7.3305.00010 ATDR 2,5 A																							
NTC-thermostat -B37 Ziehl	7.4722.1 TRN 111K 2-8	7.4722.1 TRN 111K 2-8	7.4722.1 TRN 111K 2-8	7.4722.1 TRN 111K 2-8																							
fuse socket -5FU Wöhner	7.3320.00050 Class CC 1-pol.	7.3320.00050 Class CC 1-pol.	7.3320.00050 Class CC 1-pol.	7.3320.00050 Class CC 1-pol.																							
fuse -5FU Gould	7.3310.1 ATQR 0,5 A	7.3310.1 ATQR 0,5 A	7.3310.1 ATQR 0,5 A	7.3310.1 ATQR 0,5 A																							
LED indicator -P30/P31 CML	7.5720.0 19511331 KAE green	7.5720.0 19511331 KAE green	7.5720.0 19511331 KAE green	7.5720.0 19511331 KAE green																							
terminal strip -X1 Wieland	7.3165.30070 99.500.7511.7	7.3165.30070 99.500.7511.7	7.3165.30070 99.500.7511.7	7.3165.30070 99.500.7511.7																							
cables -W34	---	2x 18 AWG 600 V, 90°C	2x 18 AWG 600 V, 90°C	2x 18 AWG 600 V, 90°C																							
<b>option C36, C37, K6</b>																											
NTC-thermostat -B37 Ziehl	7.6238.00010 TRN 122K 1-4/2-8	7.6238.00010 TRN 122K 1-4/2-8	7.6238.00010 TRN 122K 1-4/2-8	7.6238.00010 TRN 122K 1-4/2-8																							
terminal strip -X1 Wieland	7.3165.30040 99.501.7511.7	7.3165.30040 99.501.7511.7	7.3165.30040 99.501.7511.7	7.3165.30040 99.501.7511.7																							
series terminal -X1 Wieland	---	2x 896081.3 WKFN 2,5/35	2x 896081.3 WKFN 2,5/35	2x 896081.3 WKFN 2,5/35																							
cables -W34	---	4x 18 AWG 600 V, 90°C	4x 18 AWG 600 V, 90°C	4x 18 AWG 600 V, 90°C																							
<div style="display: flex; justify-content: space-between;"> <div> <p>electrical component parts list</p> <p>refrigeration dryer TA 5 - TC 44</p> <p>performance-related components</p> </div> <div style="border: 1px solid black; padding: 2px;"> <p><b>KAESER</b> KOMPRESSOREN</p> <p>Ursprung:</p> </div> </div>																											
<table border="1" style="width: 100%; border-collapse: collapse;"> <tr> <td style="width: 15%;">Datum</td> <td style="width: 15%;">07.07.2015</td> <td style="width: 15%;">Bearbeiter</td> <td style="width: 15%;">Stiller</td> <td style="width: 15%;">Geprüft</td> <td style="width: 15%;">Gegner</td> </tr> <tr> <td colspan="2">Ersatz durch:</td> <td colspan="2">Ersatz für:</td> <td colspan="2"></td> </tr> <tr> <td colspan="2">C Änderung</td> <td colspan="2">Datum</td> <td colspan="2">Name</td> </tr> </table>										Datum	07.07.2015	Bearbeiter	Stiller	Geprüft	Gegner	Ersatz durch:		Ersatz für:				C Änderung		Datum		Name	
Datum	07.07.2015	Bearbeiter	Stiller	Geprüft	Gegner																						
Ersatz durch:		Ersatz für:																									
C Änderung		Datum		Name																							

model	model-dependent components			=	+	-	page 3	4. Bl.
	TB26	TC31	TC36					
machine power supply	115 V ±10 %, 60 Hz	115 V ±10 %, 60 Hz	115 V ±10 %, 60 Hz					
manual motor controller	-Q0 Sontheimer 896595.00020 HLT40/3ZM/Z20	896595.00020 HLT40/3ZM/Z20	896595.00020 HLT40/3ZM/Z20					
contactor	-Q30 Siemens 7.8740.00330 3RT2018-1AK61	7.8740.00330 3RT2018-1AK61	7.8740.00360 3RT2025-1AK60					
fuse socket	-3FU Wöhner 7.3320.00050 Class CC 1-pol.	7.3320.00050 Class CC 1-pol.	7.3320.00050 Class CC 1-pol.					
fuse	-3FU Gould 7.3305.00010 ATDR 2,5 A	7.3305.00010 ATDR 2,5 A	7.3305.00010 ATDR 2,5 A					
NTC-thermostat	-B37 Ziehl 7.4722.1 TRN 111K 2-8	7.6238.00010 TRN 122K 1-4/2-8	7.6238.00010 TRN 122K 1-4/2-8					
fuse socket	-5FU Wöhner 7.3320.00050 Class CC 1-pol.	7.3320.00050 Class CC 1-pol.	7.3320.00050 Class CC 1-pol.					
fuse	-5FU Gould 7.3310.1 ATQR 0,5 A	7.3310.1 ATQR 0,5 A	7.3310.1 ATQR 0,5 A					
LED indicator	-P30/P31 CML 7.5720.0 19511331 KAE green	7.5720.0 19511331 KAE green	7.5720.0 19511331 KAE green					
terminal strip	-X1 Wieland 7.3165.30070 99.500.7511.7	7.3165.30040 99.501.7511.7	7.3165.30040 99.501.7511.7					
cables	-W34 600 V, 90°C	2x 18 AWG 600 V, 90°C	2x 18 AWG 600 V, 90°C					
<b>option C36, C37, K6</b>								
NTC-thermostat	-B37 Ziehl 7.6238.00010 TRN 122K 1-4/2-8	7.6238.00010 TRN 122K 1-4/2-8	7.6238.00010 TRN 122K 1-4/2-8					
terminal strip	-X1 Wieland 7.3165.30040 99.501.7511.7	7.3165.30040 99.501.7511.7	7.3165.30040 99.501.7511.7					
series terminal	-X1 Wieland 2x 896081.3 WKFN 2,5/35	2x 896081.3 WKFN 2,5/35	2x 896081.3 WKFN 2,5/35					
cables	-W34 4x 18 AWG 600 V, 90°C	4x 18 AWG 600 V, 90°C	4x 18 AWG 600 V, 90°C					
<p><b>KAESER KOMPRESSOREN</b></p> <p>electrical component parts list refrigeration dryer TA 5 - TC 44 performance-related components</p> <p>Ursprung: UTR-U3005.00</p>								
<p>07.07.2015</p> <p>Datum: 07.07.2015</p> <p>Bearbeiter: Siller</p> <p>Geprüft: Geigler</p> <p>Norm:</p> <p>Ersatz durch:</p> <p>Ersatz für:</p> <p>Ursprung:</p>								
<p>a) Datum: Name:</p> <p>b) Datum: Name:</p> <p>c) Datum: Name:</p>								

model	model-dependent components					page 4 Bl.
	TB19	TB26	TC31	TC36	TC44	
machine power supply	230 V ±10 %, 60 Hz	230 V ±10 %, 60 Hz	230 V ±10 %, 60 Hz	230 V ±10 %, 60 Hz	230 V ±10 %, 60 Hz	
manual motor controller -Q0 Sontheimer	896595.00020 HLT40/3ZM/Z20	896595.00020 HLT40/3ZM/Z20	896595.00020 HLT40/3ZM/Z20	896595.00020 HLT40/3ZM/Z20	896595.00020 HLT40/3ZM/Z20	
contactor -Q30 Siemens	7.8740.00310 3RT2016-1AK61	7.8740.00310 3RT2016-1AK61	7.8740.00310 3RT2016-1AK61	7.8740.00310 3RT2016-1AK61	7.8740.00320 3RT2017-1AK61	
fuse socket -3FU/-4FU Wöhner	7.3320.00070 Class CC 2-pol.	7.3320.00070 Class CC 2-pol.	7.3320.00070 Class CC 2-pol.	7.3320.00070 Class CC 2-pol.	7.3320.00070 Class CC 2-pol.	
fuse -3FU/-4FU Gould	7.3305.00010 ATDR 2,5 A	7.3305.00010 ATDR 2,5 A	7.3305.00010 ATDR 2,5 A	7.3305.00010 ATDR 2,5 A	7.3305.00010 ATDR 2,5 A	
NTC-thermostat -B37 Ziehl	7.4722.1 TRN111K 2-8	7.4722.1 TRN111K 2-8	7.6238.00010 TRN122K 1-4/2-8	7.6238.00010 TRN122K 1-4/2-8	7.6238.00010 TRN122K 1-4/2-8	
fuse socket -1FU/-2FU Wöhner	7.3320.00070 Class CC 2-pol.	7.3320.00070 Class CC 2-pol.	7.3320.00070 Class CC 2-pol.	7.3320.00070 Class CC 2-pol.	7.3320.00070 Class CC 2-pol.	
fuse -1FU/-2FU Gould	7.3310.1 ATQR 0,5 A	7.3310.1 ATQR 0,5 A	7.3310.1 ATQR 0,5 A	7.3310.1 ATQR 0,5 A	7.3310.1 ATQR 0,5 A	
control transformer -T31/-5FU Block	7.3902.10020 50VA 230/460 V//115 V	7.3902.10020 50VA 230/460 V//115 V	7.3902.10020 50VA 230/460 V//115 V	7.3902.10020 50VA 230/460 V//115 V	7.3902.10020 50VA 230/460 V//115 V	
fuse -5FU 5x 20	893937.0 0,4 AT	893937.0 0,4 AT	893937.0 0,4 AT	893937.0 0,4 AT	893937.0 0,4 AT	
LED indicator -P30/-P31 CML	7.5720.0 19511331 KAE green	7.5720.0 19511331 KAE green	7.5720.0 19511331 KAE green	7.5720.0 19511331 KAE green	7.5720.0 19511331 KAE green	
terminal strip -X1 Wieland	7.3165.30070 99.500.7511.7	7.3165.30070 99.500.7511.7	7.3165.30040 99.501.7511.7	7.3165.30040 99.501.7511.7	7.3165.30040 99.501.7511.7	
cables -W34	2x 18 AWG 600 V, 90°C	2x 18 AWG 600 V, 90°C	2x 18 AWG 600 V, 90°C	2x 18 AWG 600 V, 90°C	2x 18 AWG 600 V, 90°C	
<b>option C36, C37, K6</b>						
NTC-thermostat -B37 Ziehl	7.6238.00010 TRN122K 1-4/2-8	7.6238.00010 TRN122K 1-4/2-8	7.6238.00010 TRN122K 1-4/2-8	7.6238.00010 TRN122K 1-4/2-8	7.6238.00010 TRN122K 1-4/2-8	
terminal strip -X1 Wieland	7.3165.30040 99.501.7511.7	7.3165.30040 99.501.7511.7	7.3165.30040 99.501.7511.7	7.3165.30040 99.501.7511.7	7.3165.30040 99.501.7511.7	
series terminal -X1 Wieland	2x 896081.3 WKFN 2,5/35	2x 896081.3 WKFN 2,5/35	2x 896081.3 WKFN 2,5/35	2x 896081.3 WKFN 2,5/35	2x 896081.3 WKFN 2,5/35	
cables -W34	4x 18 AWG 600 V, 90°C	4x 18 AWG 600 V, 90°C	4x 18 AWG 600 V, 90°C	4x 18 AWG 600 V, 90°C	4x 18 AWG 600 V, 90°C	

electrical component parts list  
 refrigeration dryer TA 5 - TC 44  
 performance-related components  
 UTR-U3005.00  
 KAESER KOMPRESSOREN  
 Ursprung:  
 Ersatz für:  
 Ersatz durch:  
 Datum: 07.07.2015  
 Bearbeiter: Siller  
 Geprüft: Giegner  
 Norm:  
 Name:  
 Datum:  
 C: Änderung

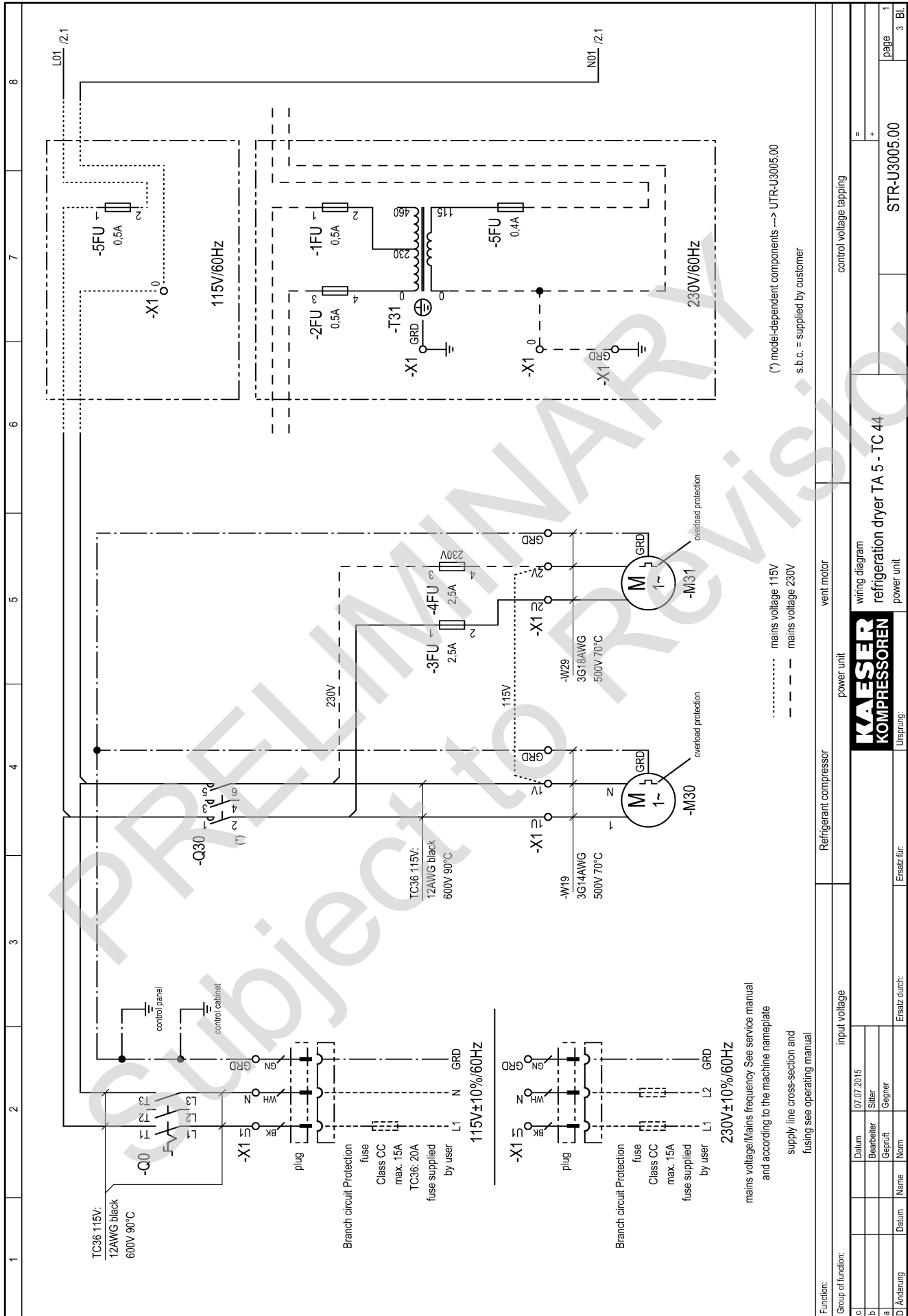

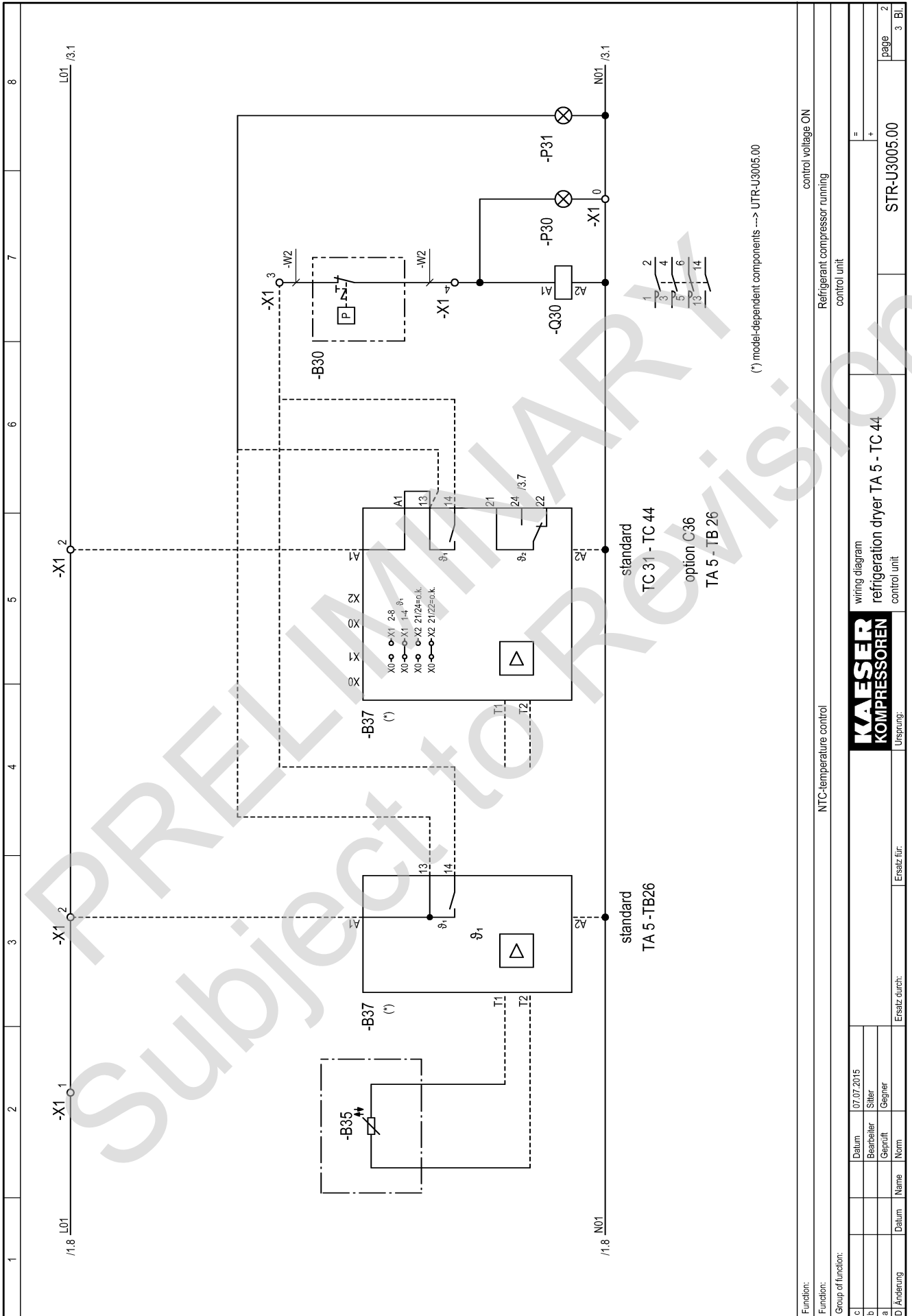

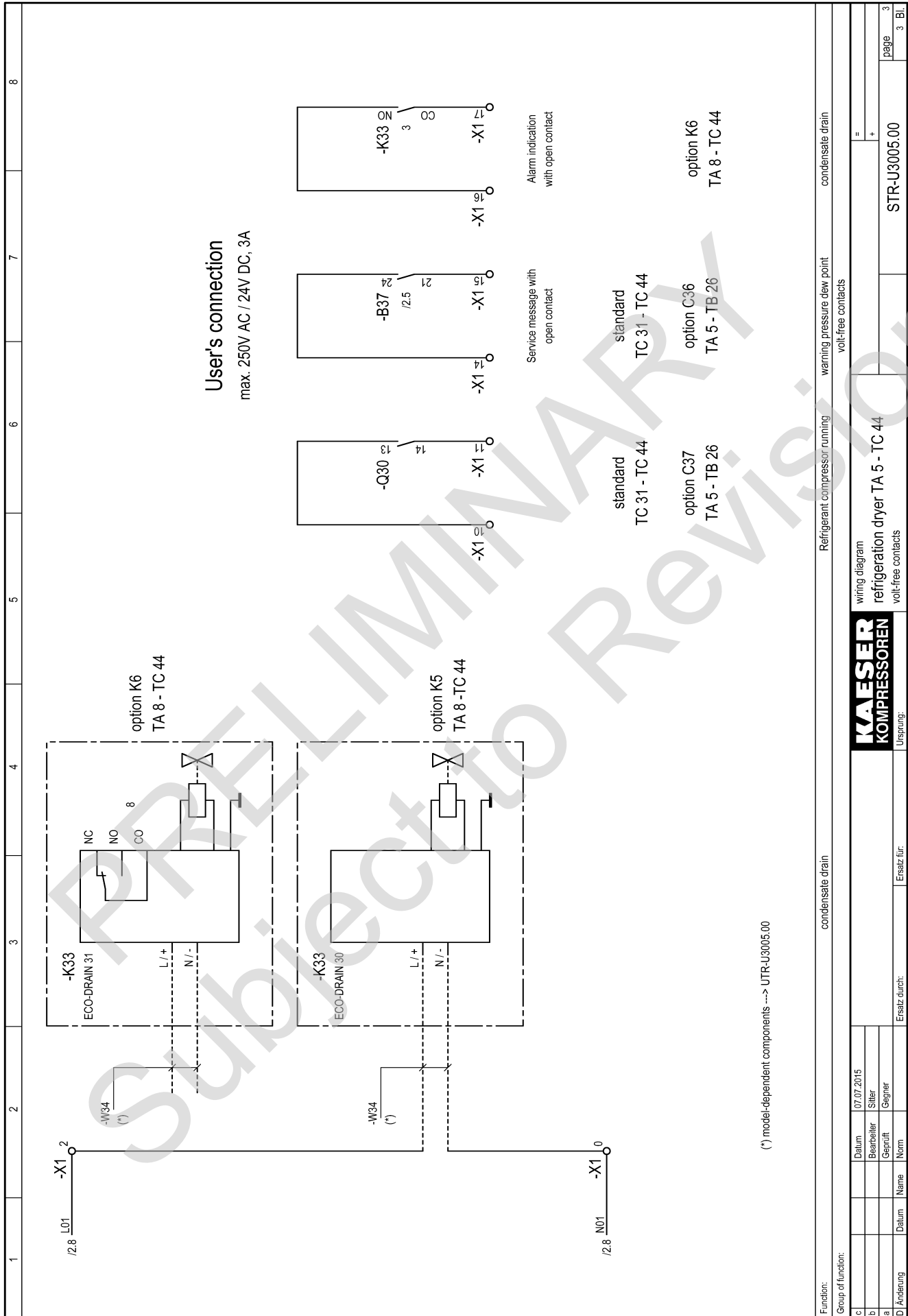

(\*) model-dependent components ---> UTR-U3005.00









PRELIMINARY  
Subject to Revision