

Installation and Operating Manual

Rotary lobe blower

BBC pr

Number: 9_9593 33 USE

Manufacturer:

KAESER KOMPRESSOREN SE

96410 Coburg • PO Box 2143 • GERMANY • Tel. +49-(0)9561-6400 • Fax +49-(0)9561-640130

www.kaeser.com

/KKW/BBBCP 2.16 en Z1 SBA-GEBLAESE

20230330 082531

1	Regarding this Document	
1.1	Using this document	1
1.2	Further documents	1
1.3	Copyright	1
1.4	Symbols and labels	1
1.4.1	Warnings	1
1.4.2	Potential damage warnings	2
1.4.3	Other alert notes and their symbols	2
2	Technical Data	
2.1	Nameplate	4
2.2	Option codes	4
2.3	Weight	5
2.4	Recommended oil	6
2.5	Lubricating oil charge	6
2.6	Temperature	6
2.7	Ambient and inlet conditions	7
2.8	Filter maintenance indicator	8
2.9	Pressure display	8
2.10	Sound pressure level/sound power level	8
2.11	Power Supply	8
2.12	Power supply specifications	9
2.13	Options	9
2.13.1	Pressure switch	9
2.13.2	Speed monitor	10
2.13.3	Unloaded start valve	11
2.13.4	Temperature gauge switch	11
2.13.5	Pressure sensor	12
2.13.6	Unloaded start valve with regulating valve	12
2.13.7	Thermostat	13
2.13.8	Filter pressure differential switch	13
2.13.9	Check valve	14
2.13.10	Auxiliary heating	14
2.13.11	Outdoor installation	15
2.13.12	Piped inlet	15
2.13.13	Fan (sound enclosure)	15
3	Safety and Responsibility	
3.1	Basic instructions	17
3.2	Specified use	17
3.3	Improper use	17
3.4	User's responsibilities	18
3.4.1	Observe statutory and universally accepted regulations	18
3.4.2	Determining personnel	18
3.5	Dangers	18
3.5.1	Safely dealing with sources of danger	18
3.5.2	Safe machine operation	21
3.5.3	Organizational measures	23
3.6	Danger areas	23
3.7	Safety devices	23
3.8	Safety signs	24
3.9	In emergency	26
3.9.1	Correct fire fighting	26
3.9.2	Remove lubricating oil from the skin.	27
3.10	Environmental protection	27

3.11	Warranty	27
4	Design and Function	
4.1	Machine	28
4.2	Blower block	29
4.3	Safety relief valve	29
4.4	Safety devices	30
4.5	Compensator	30
4.6	Filter maintenance indicator	30
4.7	Pressure gauge	30
4.8	Floating relay contacts	31
4.9	Options	31
4.9.1	Pressure switch	31
4.9.2	Speed monitor	31
4.9.3	Unloaded start valve	32
4.9.4	Temperature gauge switch	33
4.9.5	Pressure sensor	34
4.9.6	Unloaded start valve with regulating valve	34
4.9.7	Thermostat	36
4.9.8	Filter pressure differential switch	36
4.9.9	Check valve	37
4.9.10	Auxiliary heating	37
4.9.11	Outdoor installation	38
4.9.12	Piped inlet	38
4.9.13	Sound enclosure	39
5	Installation and Operating Conditions	
5.1	Ensuring safety	40
5.2	Installation conditions	40
5.2.1	Determining installation location and clearances	40
5.2.2	Ensuring adequate ventilation	41
5.3	Outdoor installation	42
6	Installation	
6.1	Ensuring safety	43
6.2	Reporting transport damage	44
6.3	Anchoring the machine	44
6.4	Connecting the machine to the power supply	44
6.4.1	For frequency control	45
6.4.2	Outdoor installation	46
6.5	Making the compressed air connection	46
6.6	Safety devices installed by the user	47
6.7	Options	47
6.7.1	Connecting the pressure switch	47
6.7.2	Connecting the speed monitor	48
6.7.3	Connecting the temperature gauge switch	48
6.7.4	Connecting the pressure sensor	48
6.7.5	Connecting the thermostat	48
6.7.6	Connecting the filter pressure differential switch	48
6.7.7	Connecting the auxiliary heater	48
6.7.8	Connecting the inlet pipe	48
6.7.9	Sound enclosure	49
6.8	BB 69 C pr, BB 89 C pr with sound enclosure: Removing transport securing devices	50
7	Initial Start-up	
7.1	Ensuring safety	51

7.2	Instructions to be observed before commissioning	52
7.3	Checking installation and operating conditions	52
7.4	Checking the direction of rotation for the drive motor	53
7.4.1	Fan (sound enclosure)	54
8	Operation	
8.1	Switching the machine on and off	55
8.1.1	Switching on	55
8.1.2	Switching off	55
8.2	Switching off in an emergency	55
8.3	Checking the ventilator fan function	56
9	Fault Recognition and Rectification	
9.1	Basic instructions	57
9.2	Faults	57
9.3	Options	58
9.3.1	Sound enclosure faults	58
9.3.2	Faulty pressure sensor	59
10	Maintenance	
10.1	Ensuring safety	60
10.2	Maintenance schedule	61
10.2.1	Logging maintenance work	61
10.2.2	Regular maintenance tasks	61
10.2.3	Regular service tasks	62
10.3	Sound enclosure	63
10.4	Drive belt maintenance	63
10.5	Checking the oil level	64
10.6	Replenishing lubricating oil	65
10.7	Changing the oil	66
10.8	Air filter maintenance	67
10.8.1	Filter maintenance indicator	68
10.8.2	Filter pressure differential switch	69
10.8.3	Changing the air filter	69
10.9	Machine cleaning	70
10.10	Motor maintenance	71
10.10.1	Permanently lubricated drive motor bearings	71
10.10.2	Fan motor (sound enclosure)	71
10.11	Testing the safety relief valve	71
10.12	Documenting maintenance and service work	73
11	Spares, Operating Materials, Service	
11.1	Note the nameplate	74
11.2	Ordering consumable parts and operating fluids/materials	74
11.3	Spare parts for service and repair	74
11.3.1	BB 52 C pr, Machine without sound enclosure	74
11.3.2	BB 52 C pr, Machine with sound enclosure	77
11.3.3	BB 69 C pr, BB 89 C pr	80
11.4	KAESER AIR SERVICE	83
11.5	Completing the contamination declaration	83
12	Decommissioning, Storage and Transport	
12.1	Decommissioning	84
12.2	Packing	84
12.3	Transport	85
12.3.1	Safety	85
12.3.2	Transport machine with a pallet truck or forklift truck	85

12.4	Storage	85
12.5	Disposal	86
13	Annex	
13.1	Pipeline and instrument flow diagram (P+I diagram)	87
13.2	Dimensional drawing	90
13.2.1	BB 52 C pr	90
13.2.2	BB 69 C pr, BB 89 C pr	94
13.3	Sound emission	98
13.4	Drive motor electrical diagram	106
13.5	Electrical diagrams for options	116
13.5.1	Pressure switch wiring diagram	116
13.5.2	Speed monitor wiring diagram	116
13.5.3	Temperature gauge switch wiring diagram	116
13.5.4	Pressure sensor connections	117
13.5.5	Thermostat wiring diagram	117
13.5.6	Filter pressure differential switch wiring diagram	118
13.5.7	Auxiliary heater wiring diagram	118
13.5.8	Fan motor wiring diagram (sound enclosure)	124
13.6	Project planning data	125

Fig. 1	Three-phase star (wye); 4 wire; center point solidly grounded	9
Fig. 2	Three-phase star (wye); 3 wire; center point solidly grounded	9
Fig. 3	Location of the safety signs on the machine	24
Fig. 4	Safety sign location, electronically actuated options	24
Fig. 5	Safety sign position, standstill heater, Option H2	25
Fig. 6	BB 69 C pr, BB 89 C pr Safety sign location, weather protection, Option H3	25
Fig. 7	Machine	28
Fig. 8	Blower block	29
Fig. 9	Safety relief valve	29
Fig. 10	Compensator	30
Fig. 11	Location of the pressure gauge	30
Fig. 12	Pressure switch	31
Fig. 13	Unloaded start valve: AFM 4, AFM 5	32
Fig. 14	Unloaded start valve: AFE 15	32
Fig. 15	Diagram of the unloaded start valve: AFE 15	33
Fig. 16	Location of the temperature gauge	33
Fig. 17	Pressure sensor	34
Fig. 18	Unloaded start valve with regulating valve	34
Fig. 19	Diagram of the unloaded start valve with regulating valve	35
Fig. 20	Thermostat	36
Fig. 21	Filter pressure differential switch	36
Fig. 22	Pressure connection to the filter pressure differential switch	36
Fig. 23	Filter pressure differential switch function	37
Fig. 24	Check valve	37
Fig. 25	Auxiliary heating	38
Fig. 26	Sound enclosure	39
Fig. 27	Recommended positioning of the machine, minimum dimensions [in.]	41
Fig. 28	Removing the transport securing devices	50
Fig. 29	Sound enclosure	63
Fig. 30	Drive belt maintenance	64
Fig. 31	Checking the oil level	65
Fig. 32	Replenishing lubricating oil	66
Fig. 33	Oil drain tap with handle	67
Fig. 34	Filter maintenance indicator (machine without sound enclosure)	68
Fig. 35	Filter maintenance indicator (machine with sound enclosure)	68
Fig. 36	Changing the air filter (BB 52 C pr)	69
Fig. 37	Changing the air filter (BB 69 C pr, BB 89 C pr)	70
Fig. 38	Checking the safety relief valve (BB 52 C pr)	71
Fig. 39	Checking the safety relief valve (BB 69 C pr, BB 89 C pr)	72
Fig. 40	Transport	85
Fig. 41	Pressure switch wiring diagram	116
Fig. 42	Speed monitor wiring diagram	116
Fig. 43	Temperature gauge switch wiring diagram	116
Fig. 44	Pressure sensor connections	117
Fig. 45	Thermostat wiring diagram	117
Fig. 46	Filter pressure differential switch wiring diagram	118
Fig. 47	Fan star-delta circuit diagram	124
Fig. 48	Fan star-delta circuit diagram	124
Fig. 49	Fan alternating current circuit diagram	124
Fig. 50	Fan alternating current circuit diagram	124

Tab. 1	Danger levels and their definition (personal injury)	1
Tab. 2	Danger levels and their definition (damage to property)	2
Tab. 3	Nameplate	4
Tab. 4	Option codes	4
Tab. 5	Weight without sound enclosure	5
Tab. 6	Weight with sound enclosure	5
Tab. 7	Recommended oil	6
Tab. 8	Lubricating oil charge	6
Tab. 9	Temperature	6
Tab. 10	Ambient and inlet conditions	7
Tab. 11	Installation altitude	7
Tab. 12	Filter maintenance indicator	8
Tab. 13	Pressure display	8
Tab. 14	Pressure switch (option C9)	9
Tab. 15	Speed monitoring sensor (Option C10)	10
Tab. 16	Speed monitoring device (Option C10)	10
Tab. 17	Setting of the speed monitor evaluation device (Option C10)	10
Tab. 18	Unloaded start valve (Option C11)	11
Tab. 19	Temperature gauge switch (Option C13)	11
Tab. 20	Pressure sensor (option C14)	12
Tab. 21	Unloaded start valve with regulating valve (Option C18)	12
Tab. 22	Thermostat (Option C19)	13
Tab. 23	Filter pressure differential switch (Option F5)	13
Tab. 24	Check valve (Option G1)	14
Tab. 25	Auxiliary heating (Option H2) BB 52 C pr	14
Tab. 26	Auxiliary heating (Option H2) BB 69 C pr & BB 89 C pr	14
Tab. 27	Thermostatic auxiliary heating (Option H2)	14
Tab. 28	BB 52 C pr: Fan motor 3~/60Hz (Option H12)	15
Tab. 29	BB 52 C pr: Fan motor 1~/60Hz (Option H12)	16
Tab. 30	BB 69 C pr, BB 89 C pr Fan motor 3~/60Hz (Option H12)	16
Tab. 31	BB 69 C pr, BB 89 C pr Fan motor 1~/60Hz (Option H12)	16
Tab. 32	Danger areas	23
Tab. 33	Safety signs	25
Tab. 34	Recommended installation, minimum dimensions	41
Tab. 35	Torques for customer pipeline	47
Tab. 36	Inlet compressor torques	49
Tab. 37	Recommissioning after storage/standstill	52
Tab. 38	Installation conditions checklist	52
Tab. 39	Faults and remedies	57
Tab. 40	Faults and remedies (option H12)	58
Tab. 41	Faults and remedies (Option C14)	59
Tab. 42	Regular maintenance tasks	61
Tab. 43	Regular maintenance tasks	62
Tab. 44	Logged maintenance tasks	73
Tab. 45	Consumable parts and operating fluids/materials	74
Tab. 46	Sound emission - legend	98

1 Regarding this Document

1.1 Using this document

This document, hereafter called the service manual, contains important information about all life phases of the machine.

The operating manual is a component of the product. It describes the machine as it was at the time of first delivery after manufacture.

- Keep the service manual in a safe place throughout the life of the machine.
- Supply any successive owner or user with this service manual.
- Please insert any amendment or revision of the service manual sent to you.
- Enter details from the machine nameplate and individual items of equipment in the table in chapter 2.

1.2 Further documents

Included with this operating manual are additional documents intended to assist in the safe operation of the machine:

- Manufacturer/installation declaration in accordance with applicable directives.

Missing documents can be requested from KAESER.

- Ensure that all documents are complete and observe the instructions contained within them.
- Ensure that you provide the data from the nameplate when ordering documents.

1.3 Copyright

This operator manual is copyright protected. Queries regarding use or duplication of the documentation should be referred to KAESER. Correct use of information will be fully supported.

1.4 Symbols and labels

- Please note the symbols and labels used in this document.

1.4.1 Warnings

Warnings indicate danger potentially resulting in personal injury, if the measures specified are not taken.

Warnings indicate three levels of danger identified by the corresponding signal word:

Signal term	Meaning	Consequences of non-compliance
DANGER	Warns of imminent danger	Will very likely result in death or severe injury
WARNING	Warns of potentially imminent danger	May result in death or severe injury
CAUTION	Warns of a potentially dangerous situation	May result in moderate physical injury

Tab. 1 Danger levels and their definition (personal injury)

1 Regarding this Document

1.4 Symbols and labels

Warning notes may precede a chapter. They apply to the entire chapter including all sub-sections.

Example:

DANGER

The type and source of the imminent danger is shown here!

The possible consequences of ignoring a warning are shown here.

The word "DANGER" indicates that death or severe injury can very likely result from ignoring the warning.

➤ *The measures required to protect yourself from danger are shown here.*

Warning notes referring to a sub-section or the subsequent step are integrated into the procedure and numbered as a step.

Example:

1.  **WARNING** *The type and source of the imminent danger is shown here!*
The possible consequences of ignoring a warning are shown here.
The word "WARNING" indicates that death or severe injury may result from ignoring the warning.
➤ *The measures required to protect yourself from danger are shown here.*
2. Always read and comply with warning instructions.

1.4.2 Potential damage warnings

Contrary to the warnings shown above, damage warnings do not indicate potential personal injury.

Damage warnings have only one danger level, identified by this signal word:

Signal term	Meaning	Consequences of non-compliance
NOTE	Warns of a potentially dangerous situation	Damage to property is possible

Tab. 2 Danger levels and their definition (damage to property)

Example:

NOTICE

The type and source of the imminent danger is shown here!

Potential effects when ignoring the warning are indicated here.



➤ *The protective measures against the damages are shown here.*

➤ Carefully read and fully comply with warnings against damages.

1.4.3 Other alert notes and their symbols



This symbol indicates particular important information.

- Material** Here you will find details on special tools, operating materials or spare parts.
- Precondition** Here you will find conditional requirements necessary to carry out the task.
The conditional requirements relevant to safety shown here will help you to avoid dangerous situations.
- Option H12** ➤ This symbol is placed by lists of actions comprising one stage of a task.
Operating instructions with several steps are numbered in the sequence of the operating steps.
Information relating to one option only are marked with an option code (e.g., H12 indicates that this section applies only to machines with sound enclosure). Option codes used in this operating manual are explained in chapter 2.2.
-  Information referring to potential problems are identified by a question mark.
The cause is specified in the help text ...
➤ ... as is a solution.
-  This symbol refers to important information or measures concerning environmental protection.
- Further information** Further subjects are introduced here.

2 Technical Data

2.1 Nameplate

The machine's nameplate provides the model designation and important technical information. The nameplate is attached to the machine stand and at the left side wall of the sound enclosure (Option H12).

The nameplate data relates to Standard intake state of 14.7 psi and 68 °F.

➤ Enter the data from the nameplate here as a reference.

Feature	Value
Rotary lobe blowers	
Material No.	
Serial No.	
Ambient temperature	
Rated motor power	
Max. working pressure PS	
Rated motor speed	
Full load current	
Full load current drive motor	
Power supply	
Electrical diagram	
Year of manufacture	

Tab. 3 Nameplate

2.2 Option codes

The table contains a list of possible options.

➤ Enter options here as a reference:

Option	Option code	Installed?
Operating mode: Gauge pressure	B13	✓
Oil level monitoring	C5	—
Pressure switch	C9	
Speed monitor	C10	
Unloaded start valve (AFE)	C11	
Temperature gauge switch	C13	
Pressure transducer	C14	
Unloaded start valve with regulating valve (AFR)	C18	
Thermostat	C19	

Installed: ✓

Not available: —

Option	Option code	Installed?
Under frequency control	C32	
Filter differential pressure switch	F5	
Check valve	G1	
Auxiliary heating	H2	
Outdoor installation	H3	
Intake from pipe network	H11	
Sound enclosure	H12	
Installed: ✓		
Not available: —		

Tab. 4 Option codes

2.3 Weight

The values shown are maximum values. The actual weight of individual machines depends on equipment fitted.

Machine without sound enclosure

Rated power [hp]	Weight [lb]		
	BB 52 C pr	BB 69 C pr	BB 89 C pr
2.0	220	—	—
3.0	232	—	—
4.0	243	—	—
5.0	265	342	353
7.5	287	364	375
10.0	309	386	397
15.0	—	419	430
20.0	—	430	441
—	—	—	—

Tab. 5 Weight without sound enclosure

Option H12 Machine with sound enclosure

Rated power [hp]	Weight [lb]		
	BB 52 C pr	BB 69 C pr	BB 89 C pr
2.0	375	—	—
3.0	386	—	—
4.0	397	—	—
5.0	419	628	639
7.5	441	650	661
10.0	463	672	683

Rated power [hp]	Weight [lb]		
	BB 52 C pr	BB 69 C pr	BB 89 C pr
15.0	—	705	717
20.0	—	717	728
—	—	—	—

Tab. 6 Weight with sound enclosure

2.4 Recommended oil

The lubricant type to be used depends on the operating conditions.

	OMEGA FLUID	
	SB 220	FGB 220
Description	Synthetic oil	Synthetic oil
Application	Suitable for all applications, except food processing.	Specifically for applications where the compressed air comes into contact with food products.

Tab. 7 Recommended oil

Further information An adhesive label identifying the used lubricating oil is attached to the blower block and the belt guard.
 Information on ordering oil is found in chapter 11.2.

2.5 Lubricating oil charge

The block oil chambers are filled with oil at the factory.

Guide value

	Drive-end	Gear-end
Lubricating oil charge [qt]	0.16 ±15%	0.14 ±15%

Tab. 8 Lubricating oil charge

2.6 Temperature

	BB 52 C pr	BB 69 C pr	BB 89 C pr
Maximum block discharge temperature [°F]	320	320	320
Maximum temperature differential [°F] *	115	115	115

*Discharge temperature minus inlet temperature

Tab. 9 Temperature

2.7 Ambient and inlet conditions

The following conditions must be maintained:

- Atmosphere in the immediate vicinity of the machine is free of salt.
- The air must be free of chemicals or explosive substances.

	BB 52 C pr	BB 69 C pr	BB 89 C pr
Permissible ambient temperature [°F]	23 – 104	23 – 104	23 – 104
Machine with connected auxiliary heating and sound enclosure (Options H2, H12)	5 – 104	5 – 104	5 – 104
Permissible ambient temperature [°F]			
Permissible inlet temperature [°F]	5 – 104	5 – 104	5 – 104
Relative humidity [%]	0 – 80	0 – 80	0 – 80

Tab. 10 Ambient and inlet conditions



Differing ambient and inlet conditions require recalculation of the performance data, and are permissible only upon agreement with the manufacturer.

Further information

The wiring diagram for Option H2 in chapter 13.5.7 contains further details regarding electrical connection.

Installation altitude



The maximum permissible installation altitude depends on the main frequency and machine optional equipment.

An installation altitude > 3280 ft [AMSL] leads to performance restriction of the machine, which has already been taken into account in the project planning data sheet in chapter 13.6.

Option H12, Sound enclosure	Option C19, Thermostat	Maximum installation altitude AMSL [ft]
—	—	9842
✓	—	9842
✓	✓	6562

Main frequency available / option available: ✓

Not available. —

Tab. 11 Installation altitude

2.8 Filter maintenance indicator

Feature	Data
Indicator range [psi]	0 – 0.8

Tab. 12 Filter maintenance indicator

2.9 Pressure display

Feature	Data
Indicator range [psig]	0 – 23.2

Tab. 13 Pressure display

2.10 Sound pressure level/sound power level

Operating state LOAD under the following conditions:

- Nominal speed
- Nominal flow rate
- Nominal pressure

Measuring condition according to DIN EN ISO 2151 and basic standard ISO 9614–2:

- Measurement distance: 3 ft.
- Tolerance: ± 3 dB(A)
- Sound insulated pipeline

Further information The sound pressure level and sound power level values for your machine are provided in the tables shown in chapter 13.3.

These values refer to the design condition. They do not apply to machines with a frequency converter.

2.11 Power Supply

Basic requirements

The machine is designed for an electrical supply according to National Electric Code (NEC), edition 2020, particularly article 670 and NFPA 79, edition 2021, particularly section 4.3. In the absence of any user-specified alternatives, the limits given in these standards must be adhered to. Consult manufacturer for any other specific power supply.

The incoming line within the control panel should be as short as possible.

If external sensors or communication lines are to be connected to the machine, use shielded cables and insert the same through EMC fittings into the control panel.

Three-phase

Do **NOT** operate package on any unsymmetrical power supply. Also do **NOT** operate package on power supplies such as a three phase WYE system with center point not solidly grounded or three-phase (open) delta.

The machine requires a symmetrical three-phase power supply transformer with a WYE configuration output as shown in Figure 1 and Figure 2. In a symmetrical three phase supply the phase angles and voltages are all the same.

Other power supplies are not suitable.

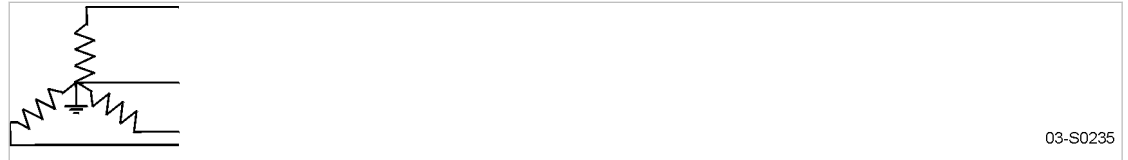

Fig. 1 Three-phase star (wye); 4 wire; center point solidly grounded

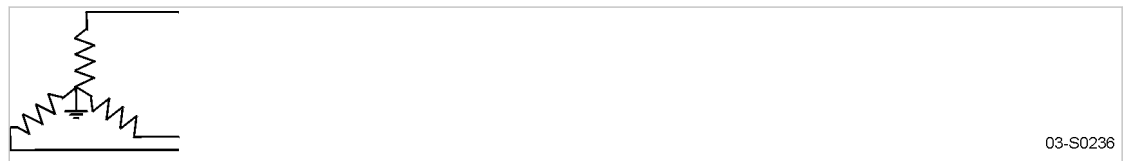

Fig. 2 Three-phase star (wye); 3 wire; center point solidly grounded

Further information Please contact an authorized KAESER service representative for options.
The electrical diagram 13.4 contains further specifications for electrical connection.

2.12 Power supply specifications

The following multi-strand copper core wires are given according to 2020 NEC 310.14, 310.15, 310.16 and table 310.16 adjusted for 40°C ambient temperature.

If other local conditions prevail, like for example high temperature, the cross section should be checked and adjusted according to 2020 NEC 110.14(C). 220.3. 310.14. 310.15. 310.16, 310.15(B)(1), table 310.15(C)(1). 430.6. 430.22. 430.24. 670.4(A) and other local codes.

Dual element time delay fuses are selected according to 2020 NEC 240.6. 430.52 and tables 430.52. 430.248 and 430.250.

We strongly suggest using a separate copper conductor for the equipment GROUNDING. 2020 NEC table 250.122 will point out the “minimum size”, however, we recommend a ground conductor the same size as the power leads, if local codes allow.

2.13 Options

Technical data for the options available for your machine are given in the following.

2.13.1 Option C9 Pressure switch

Feature	Data	
Max. contact load at 250 V [A]	Inductive load	0.5
	Resistive load	1.0

Feature	Data
Protection (with cover, electrical connection upwards)	IP54

Tab. 14 Pressure switch (option C9)

Further information The wiring diagram for option C9 in chapter 13.5 contains further details of the power supply connection.

2.13.2 Option C10 Speed monitor

Sensor

Feature	Data
Rated switching distance S_n [in.]	0.04 – 0.12
Installation conditions	Not flush
Output function	DC PNP/NPN
Enclosure protection	IP 67
Connection	M12
Working principle	Inductive

Tab. 15 Speed monitoring sensor (Option C10)

Sensor

Feature	Data
Rated voltage [V]	110 – 240 AC/DC (50 – 60 Hz) / 27 DC (typ. 24 DC)
Contact load capacity	6 A (250 V AC); B300, R300
Power consumption [VA]	5
Start override [s]	0 – 1000
Ambient temperature [°F]	-4 – +140
Degree of protection - enclosure/terminals	IP 50 / IP 20
Cable connection	up to 2.5 mm ² (AWG 14)

Tab. 16 Speed monitoring device (Option C10)

Sensor setting

Feature	Data		
Display format	DIM=0 (rpm)		
Number of control caps, input 1	NC1=2		
Memory function outputs 1 and 2	SO1=0 (inactive)	SO2=0 (inactive)	
Switching function outputs 1 and 2	FO1=2	FO2=3	AO3=4.0
Analogue starting value for analogue output 3 [mA]			

Feature	Data		
Switching point outputs 1 and 2 [rpm] Analogue starting value for analogue output 3 [rpm]	SP1=500	SP2=1000	FA3=1000
Hysteresis for switching points 1 and 2 [%]	HY1=3	HY2=5	
Start override time outputs 1 and 2 [s]	ST1=60.0	ST2=0.0	
Delay time outputs 1 and 2 [s]	DT1=10.0	DT2=0.0	
Wiping function outputs 1 and 2 [s]	FT1=0.0	FT2=0.0	

Tab. 17 Setting of the speed monitor evaluation device (Option C10)

Further information The wiring diagram for Option C10 in chapter 13.5 contains further details of the power supply connection.

2.13.3 Option C11 Unloaded start valve

Type	AFM 4	AFM 5	AFE 15
Permissible pressure [psi] (a)	0 – 29	0 – 29	0 – 29
Maximum delivery [cfm]	141	177	530
Inlet connection (DIN ISO 228–1)	G 1 1/4	G 2	G 2 A
Outlet connection (DIN ISO 228–1)	G 1 1/4	G 2	—
Voltage [V]	—	24, DC	—
	110, 1 Ph, 60 Hz	110, 1 Ph, 60 Hz	—
Connecting socket	Type 2508 according to DIN EN 175301–803 Form A	Type 2508 according to DIN EN 175301–803 Form A	—
Degree of protection	IP65	IP65	—

Tab. 18 Unloaded start valve (Option C11)

2.13.4 Option C13 Temperature gauge switch

Feature	Data	
Switching capacity at 250 V(AC) [A] Single pole micro-switch with changeover contact	Inductive load	1.5
	Resistive load	5.0
Switching differential of the scale range [%]	<3	
Switching point tolerance [%] (of the scale range related to the cut-out point at rising temperature)	±5	

Feature		Data
Minimum voltage [V] [AC]		24
Minimum current [mA] (Switching safety)		20
Enclosure protection	Front	IP 53
	Rear	IP 54

Tab. 19 Temperature gauge switch (Option C13)

Further information The electrical diagram for Option C13 in chapter 13.5 contains further details for the power supply connection.

2.13.5 Option C14 Pressure sensor

Feature	Data
Output signal [mA]	4 – 20
Parasitic energy [V]	$U_B = DC 10 - 30$
Permissible apparent resistance [Ohm]	$R_A = (U_B [V] - 10 V) / 0.02 A$
Enclosure protection	IP 65

Tab. 20 Pressure sensor (option C14)

Further information The wiring diagram for option C14 in chapter 13.5 contains further details of the power supply connection.

2.13.6 Option C18 Unloaded start valve with regulating valve

Type	AFR 10	—
Permissible pressure [psi] (a)	0 – 29	—
Maximum flow rate [cfm]	353	—
Maximum pressure differential [psi]	13.8	—
Regulating range [psi]	2.9 – 13.8	—
Nominal width (DIN ISO 228–1)	G 2 A	—
Control line connection (DIN ISO 228–1)	R 1/8 A	—

Tab. 21 Unloaded start valve with regulating valve (Option C18)

**2.13.7 Option C19, H12
Thermostat**

Feature	Data
Spring switch with change-over contact	1-pole
Switching capacity NC contact (1-2)	AC 230 V / 2.5 A / $\cos\phi=0.6$ AC 230 V / 16 A / $\cos\phi=1$ DC 230 V / 0.25 A
Switching capacity NO contact (1-4)	AC 230 V / 2.5 A / $\cos\phi=0.6$ AC 230 V / 6.3 A / $\cos\phi=1$ DC 230 V / 0.25 A
Switching differential scale starting position [%]	6
Switching differential scale end position [%]	1.5
Enclosure protection	IP 54

Tab. 22 Thermostat (Option C19)

Further information The electrical diagram for Option C19 in chapter 13.5 contains further details for the power supply connection.

**2.13.8 Option F5
Filter pressure differential switch**

Feature	Data
Pressure differential, adjustable [psi]	0.04 – 0.73
Voltage [V]	(AC) eff., min. 10 (AC) max. 250 (DC) min. 12 (DC) max. 48
Rated current [A]	(AC) 10
Switching current	(AC) eff., min. 20 mA (AC) max. 6 A, $\cos\phi = 1.0$ (AC) max. 3 A, $\cos\phi = 0.6$ (DC) min. 20 mA (DC) max. 1 A
Enclosure protection	IP 54

Tab. 23 Filter pressure differential switch (Option F5)

Further information The electrical diagram for Option F5 in chapter 13.5 contains further details for the power supply connection.

2.13.9 Option G1
Check valve

Feature	Value
Max. pressure and back pressure [psig]	21.8

Tab. 24 Check valve (Option G1)

2.13.10 Option H2, H12
Auxiliary heating
BB 52 C pr

Rated voltage [V]	115	208	230
Heating capacity [hp]	0.2	0.2	0.2
Number of radiators	1	1	1

Tab. 25 Auxiliary heating (Option H2) BB 52 C pr

BB 69 C pr & BB 89 C pr

Rated voltage [V]	110–265
Heating capacity [hp]	0.2
Number of radiators	1

Tab. 26 Auxiliary heating (Option H2) BB 69 C pr & BB 89 C pr

Thermostat

The thermostat data applies to BB 52 C pr, BB 69 C pr, and BB 89 C pr.

Feature	Value
Spring switch with changeover contact	1-pole
Switching capacity NC contact (1-2)	AC 230 V / 2.5 A / $\cos\phi=0.6$ AC 230 V / 16 A / $\cos\phi=1$ DC 230 V / 0.25 A
Switching capacity NO contact (1-4)	AC 230 V / 2.5 A / $\cos\phi=0.6$ AC 230 V / 6.3 A / $\cos\phi=1$ DC 230 V / 0.25 A
Switching differential scale starting position [%]	6
Switching differential scale end position [%]	1.5
Enclosure protection	IP 54

Tab. 27 Thermostatic auxiliary heating (Option H2)

Further information The wiring diagram for Option H2 in chapter 13.5 contains further details for the power supply connection.

**2.13.11 Option H3, H12
Outdoor installation**
BB 69 C pr, BB 89 C pr

The operator is responsible for protection against lightning strikes.

Material Weather protection roof

- Note the maximum permissible loads. For example, for snow load zone 2 and wind load zone 2, see DIN EN 1991 Effects on structures-snow loads and wind loads.



Deviating loads for outdoor installation may require design modifications and are only permissible following consultation with the manufacturer.

**2.13.12 Option H11
Piped inlet**

The dimensional drawings in chapter 13.2 include connection dimensions.

**2.13.13 Option H12
Fan (sound enclosure)**

Install devices for short-circuit and overload protection.

Set overload protection devices to 1.1 times the nominal value.

Further information See chapter 6.7.9.2 for information regarding fan connection.

2.13.13.1 BB 52 C pr

In the case of drive motors with a rated power of <math><5\text{ hp}</math>, a fan is only fitted inside the sound enclosure if the machine is equipped for operation via frequency converter (Option C32).

Mains frequency: 60 Hz

Three-phase current

Rated voltage [V]	Δ -208/Y-360	Δ -220/Y-380	Δ -230/Y-400	Y-460	Y-575
Maximum flow rate [cfm]	318	318	318	318	303
Current consumption $\pm 10\%$ [A]	0.73/0.42 *	0.73/0.42 *	0.73/0.42 *	0.38 *	0.37 *
Protection class	IP55	IP55	IP55	IP55	IP55

*See chapter 13.5.8, Figure 48 for connection wiring diagram.

Tab. 28 BB 52 C pr: Fan motor 3~/60Hz (Option H12)

Alternating current

Rated voltage [V]	115	230
Maximum flow rate [cfm]	303	303
Current consumption ±10% [A]	2.40 *	1.35 *
Protection class	IP55	IP55

*See chapter 13.5.8, Figure 50 for connection wiring diagram.

Tab. 29 BB 52 C pr: Fan motor 1~/60Hz (Option H12)

2.13.13.2 BB 69 C pr, BB 89 C pr
Mains frequency: 60 Hz
Three-phase current

Rated voltage [V]	Δ-208/ Y-360	Δ-220/ Y-380	Δ-230/ Y-400	Y-460
Maximum flow rate [cfm]	1059	1059	1177	1118
Current consumption ±10% [A]	0.43/0.25 *	0.43/0.25 *	0.45/0.26 *	0.35 **
Protection class	IP44	IP44	IP44	IP55

*The minimum current consumption value is indicated on the fan nameplate, the maximum current consumption value can be found in the table. See chapter 13.5.8, Figure 47 for connection wiring diagram.

**See chapter 13.5.8, Figure 48 for connection wiring diagram.

Tab. 30 BB 69 C pr, BB 89 C pr Fan motor 3~/60Hz (Option H12)

Alternating current

Rated voltage [V]	115	230
Maximum flow rate [cfm]	1118	1177
Current consumption ±10% [A]	2.90 **	0.71 *
Protection class	IP55	IP44

*The minimum current consumption value is indicated on the fan nameplate, the maximum current consumption value can be found in the table. See chapter 13.5.8, Figure 49 for connection wiring diagram.

**See chapter 13.5.8, Figure 50 for connection wiring diagram.

Tab. 31 BB 69 C pr, BB 89 C pr Fan motor 1~/60Hz (Option H12)

3 Safety and Responsibility

3.1 Basic instructions

The machine is manufactured to the latest engineering standards and acknowledged safety regulations. Nevertheless, dangers can arise through its operation:

- Danger to life and limb of the operator or third parties,
- Damages to the machine and other material assets.



Disregard of warning or safety instructions can cause serious injuries!

- Read the operating and installation manual carefully and take note of the contents for safe machine operation.
- Use this machine only if it is in a technically perfect condition and only for the purpose for which it is intended; observe all safety measures and the instructions in the service manual!
- Immediately rectify (have rectified) any faults that could be detrimental to safety!

3.2 Specified use

The machine is designed exclusively for the generation of pressure in a commercial or industrial environment where air (in the following "compressed air") as delivery medium is approved for use. Any other use is considered incorrect. The manufacturer is not liable for any damages that may result from incorrect use. The user alone is liable for any risks incurred.

- Comply with the instructions in this operating manual.
- Operate the machine only within its performance limits and under the permitted ambient conditions.
- Do not use compressed air for breathing purposes unless it is specifically treated.
- Do not use compressed air for any application that will bring it into direct contact with food products unless it is specifically treated.
- Operate the blower block only with inlet and outlet ports connected.

3.3 Improper use

Improper usage can cause damage to property and/or (severe) injuries.

- Only use the machine as intended.
- Never direct compressed air at persons or animals.
- Use hot cooling air for heating purposes only if there is no risk to the health of humans or animals. If necessary, hot cooling air should be treated by suitable means.
- Do not allow the machine to take in toxic, acidic, flammable, or explosive gases or vapors.
- Do not operate the machine in areas in which specific requirements with regard to explosion protection are in force.
- Intake of solid particles >0.004 inch is not permitted.

3.4 User's responsibilities

3.4.1 Observe statutory and universally accepted regulations

These are, for example, nationally implemented European directives and/or applicable national legislation, safety and accident prevention regulations.

- Observe relevant statutory and accepted regulations during installation, operation and maintenance of the machine.

3.4.2 Determining personnel

Suitable personnel are experts who, by virtue of their training, knowledge and experience as well as their knowledge of relevant regulations can assess the work to be done and recognize the possible dangers involved.

Authorized operating personnel possess the following qualifications:

- they are of legal age,
- are familiar with and adhere to the safety instructions and sections of the operating manual relevant to operation,
- they have received adequate training and authorization to operate electrical and compressed air devices,

Authorized installation and maintenance personnel have the following qualifications:

- they are of legal age,
- must have read, be familiar with and adhere to the safety instructions and sections of the operating manual applicable to installation and maintenance,
- are familiar with the safety concepts and regulations of electrical and compressed air engineering,
- are able to recognize the possible dangers of electrical and compressed air devices and take appropriate measures to safeguard persons and property,
- have received adequate training in and authorisation for the safe installation and maintenance of this machine.

- Ensure that personnel entrusted with operation, installation and maintenance are qualified and authorized to carry out their tasks.

3.5 Dangers

Basic instructions

Information concerning the various forms of danger that can arise during machine operation are found here.

Basic safety instructions are found in this service manual at the beginning of each chapter in the section entitled 'Safety'.

Warning instructions are found before a potentially dangerous task.

3.5.1 Safely dealing with sources of danger

The following describes the various forms of danger that can occur during machine operation.

Electricity

Touching voltage carrying components can result in electric shocks, burns or death.

- All power supplies must be fitted with lockable power supply disconnecting devices by the user.
- Allow only qualified and authorized electricians or trained personnel under the supervision of a qualified and authorized electrician to carry out work on electrical equipment according to electrical engineering regulations.
- Before commissioning or recommissioning the machine, the user must ensure adequate protection against electric shock from direct or indirect contact.
- Before starting any work on electrical equipment:
Switch off and lock out the power supply disconnecting device and verify the absence of any voltage.
- Switch off any external power sources.
These may be connections to the electric machine heating for example.
- Use fuses corresponding to machine power.
- Regularly check that all electrical connections are tight and in proper condition.

Forces of compression

Compressed air is contained energy. Uncontrolled release of this energy can cause serious injury or death. The following information concerns work on components that could be under pressure.

- Close shut-off valves or otherwise isolate the machine from the distribution network to ensure that no compressed air can flow back into the machine.
- Depressurize all pressurized components and enclosures.
- Allow no person or thing to remain near the blow-off valve during machine operation. In the event of operating pressure being exceeded, hot gas is blown off at high velocity and the valve tension rod is blown upward with great force.
- Do not carry out welding, heat treatment or mechanical modifications on pressurized components, as this influences the components' resistance to pressure.
The safety of the machine is then no longer ensured.

Compressed air quality

The composition of the compressed air must be suitable for the actual application in order to preclude health and life-threatening dangers.

- Use appropriate systems for air treatment before using the compressed air from this machine as breathing air and/or for the processing of food products.
- Use food-grade lubricating oil whenever compressed air is to come into contact with food products.

Spring forces

Springs under tension or compression store energy. Uncontrolled release of this energy can cause serious injury or death.

Safety relief valve and unloaded-start valve are under powerful spring loading.

- Do not open or dismantle any valves.

Rotating components

Touching the fan wheel (sound enclosure) or the belt drive while the machine is running can result in serious injury.

- Do not remove separating protective installations when the machine is running.
- Switch off and lock out the power supply disconnecting device and verify the absence of any voltage.
- Wear close-fitting clothes and a hair net if necessary.
- Ensure that all covers and safety guards are in place and secured before restarting.

Temperature

High temperatures are generated during compression. Touching hot components may cause injuries.

- Avoid contact with hot components.
These include, for example, blower blocks, silencers, oil and compressed air lines, motors, and machine heaters.
- Wear protective clothing.
- If welding is carried out on or near the machine, take adequate measures to prevent sparks or heat from igniting oil vapors or parts of the machine.

Noise

The sound enclosure reduces the machine noise to a tolerable level. This function will be effective only if the sound enclosure is closed.

- Wear hearing protection if necessary.
The blowing off of the safety relief valve can be particularly loud.

Operating fluids/materials

The used operating fluids and materials can cause adverse health effects. Suitable safety measures must be taken in order to prevent injuries.

- Strictly forbid fire, open flame, and smoking.
- Follow safety regulations when dealing with oils, lubricants, and chemical substances.
- Avoid contact with skin and eyes.
- Do not inhale oil mist and vapors.
- Do not eat or drink while handling lubricants.
- Keep suitable fire extinguishing agents ready for use.
- Use only KAESER approved operating materials.

Unsuitable spare parts

Unsuitable spare parts compromise the safety of the machine.

- Use only spare parts approved by the manufacturer for use in this machine.
- Use only genuine KAESER replacement parts on pressure bearing parts.

Conversion or modification of the machine

Modifications, additions, or conversions of the machine can result in unpredictable dangers.

- Do not convert or modify the machine!
- Obtain written approval by the manufacturer prior to any technical modification or expansion of the machine, the controller, or the control programs.

Extending or modifying the compressor station

If dimensioned appropriately, safety relief valves reliably prevent an impermissible rise in pressure. New dangers may arise if you modify or extend the blower air station.

- If an air distribution network is to be extended or changed: Check the capacity of the blow-off valves before installing any new machines.
- Blow-off valves of insufficient capacity must be replaced by valves with higher capacity.

3.5.2 Safe machine operation

The following is information supporting you in the safe handling of the machine during individual product life phases.

Personal protective equipment

When working on the machine you may be exposed to dangers that can result in accidents with severe adverse health effects.

- Wear protective clothing as necessary.

Suitable protective clothing (examples):

- Safety work wear
- Protective gloves
- Safety boots
- Eye protection
- Ear protection

Transport

The weight and size of the machine require safety measures during its transport to prevent accidents.

- Use suitable lifting gear that conforms to local safety regulations.
- Allow transportation only by personnel trained in the safe movement of loads.
- Attach lifting gear only to suitable lifting points.
- Be aware of the center of gravity to avoid tipping.
- Make sure the danger zone is clear of personnel.
- Do not step onto machine components to climb up the machine.

Assembly

- Make sure no power is applied when electrical connections are made.
- Use only electrical cables that are suitable and approved for the surroundings and electrical loads applied.
- Never dismantle compressed air pipes until they are fully vented.
- Only use pressure lines that are suitable and approved for the maximum working pressure and the intended medium.
- Do not allow connection pipes to be placed under mechanical stress.

- Do not induce any forces into the machine via the connections, so that the compressive forces must be balanced by bracing.
- Do not step onto machine components to climb up the machine.

Installation

A suitable installation location for the machine prevents the potential for accidents and faults.

- Install the machine in a suitable compressor room.
- Ensure sufficient and suitable lighting such that the display can be read and work carried out comfortably and safely.
- Ensure accessibility so that all work on the machine can be carried out without danger or hindrance.
- If installed outdoors, the machine must be protected from frost, direct sunlight, dust, rain and splashing water.
- Do not operate in areas in which specific requirements with regard to explosion protection are in force.
- Ensure adequate ventilation.
- Place the machine in such a manner that the working conditions in its environment are not impaired.
- Comply with limit values for ambient temperature and humidity.
- The intake air must not contain any damaging contaminants, Damaging contaminants are for instance: explosive or chemically instable gases and vapors, acid or base forming substances such as ammonia, chlorine or hydrogen sulfide.
- Do not position the machine in the warm exhaust air flow from other machines.
- Keep suitable fire extinguishing agents ready for use.

Commissioning, operation and maintenance

During commissioning, operation and maintenance you may be exposed to dangers resulting from, e.g., electricity, pressure and temperature. Careless actions can cause accidents with severe adverse effects for your health.

- Allow maintenance work to be carried out only by authorized personnel.
- Wear close-fitting, flame-resistant clothing. Wear protective clothing as necessary.
- Switch off and lock out the power supply disconnecting device and verify the absence of any voltage.
- Check that there is no voltage on floating relay contacts.
- Close shut-off valves or otherwise isolate the machine from the distribution network to ensure that no compressed air can flow back into the machine.
- Depressurize all pressurized components and enclosures.
- Allow the machine to cool down.
- Do not open the sound enclosure while the machine is switched on.
- Do not open or dismantle any valves.
- Use only spare parts approved by KAESER for use in this machine.
- Carry out regular inspections:
for visible damage,
of safety installations,
of the EMERGENCY STOP push button,
of any components requiring monitoring.

- Pay particular attention to cleanliness during all maintenance and repair work. Cover components and openings with clean cloths, paper or tape to keep them clean.
- Do not leave any loose components, tools or cleaning rags on or in the machine.
- Components removed from the machine can still be dangerous.
Do not attempt to open or destroy any components taken from the machine.

Decommissioning, storage and disposal:

Improper handling of old operating fluids and components represent a danger for the environment.

- Drain off fluids and dispose of them according to applicable environmental regulations. These include, for example, lubricating oil.
- Dispose of the machine in accordance with local environmental regulations.

3.5.3 Organizational measures

- Designate personnel and their responsibilities.
- Give clear instructions on reporting faults and damage to the machine.
- Give instructions on fire reporting and fire-fighting measures.

3.6 Danger areas

The table gives information on areas dangerous to personnel.

Only authorized personnel may enter these areas.

Function	Danger area	Authorized personnel
Transporting	Within a 10 ft radius of the machine.	Installation personnel for transporting preparation. No personnel during transporting.
	Beneath the lifted machine.	No personnel!
Installation	Within the machine. Within 3 ft radius of the machine and its power supply cables.	Installation personnel
Operation	Within a 3 ft radius of the machine.	Operating personnel
Maintenance	Within the machine.	Maintenance personnel
	Within a 3 ft radius of the machine.	

Tab. 32 Danger areas

3.7 Safety devices

Various safety devices ensure safe working with the machine.

- Do not change, bypass or disable safety devices.
- Check safety devices for correct function regularly.
- Do not remove or obliterate labels and notices.
- Ensure that labels and notices are clearly legible.

Further information More information on safety devices is contained in chapter 4, section 4.4.

3.8 Safety signs

The illustration shows the location of the safety signs on the machine. Table 33 lists the various safety signs used and their meanings.

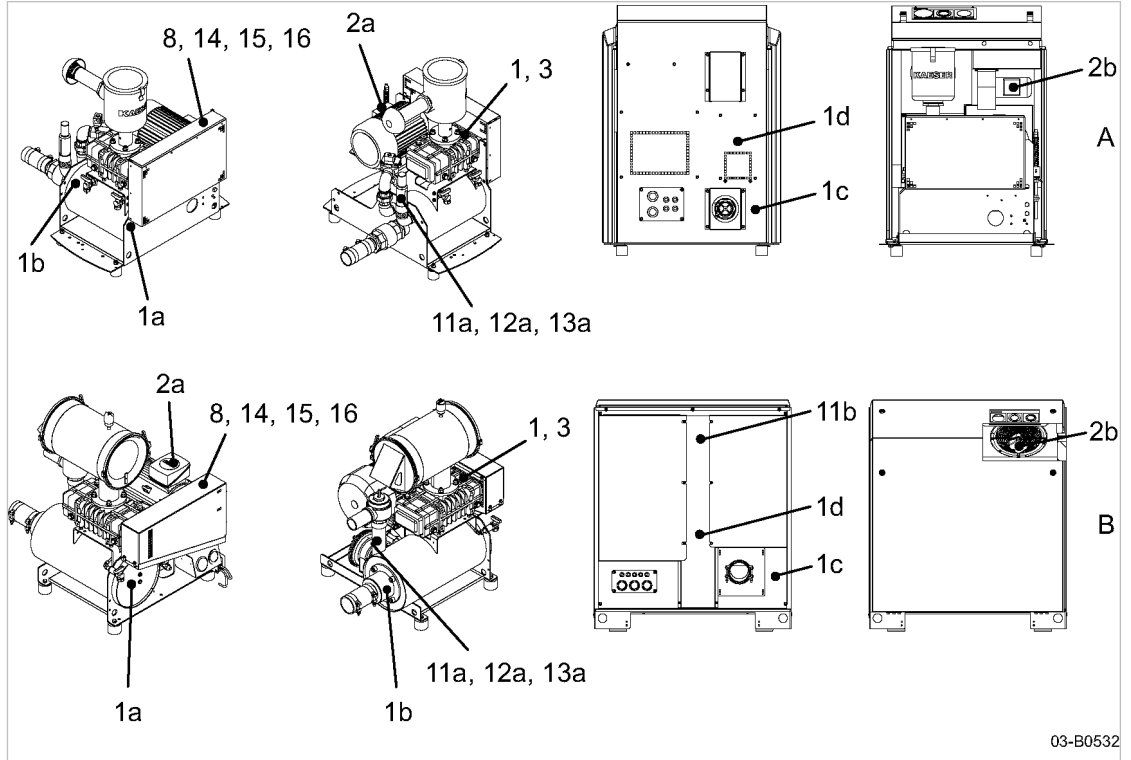

Fig. 3 Location of the safety signs on the machine

- A** BB 52 C pr
- B** BB 69 C pr, BB 89 C pr

Options

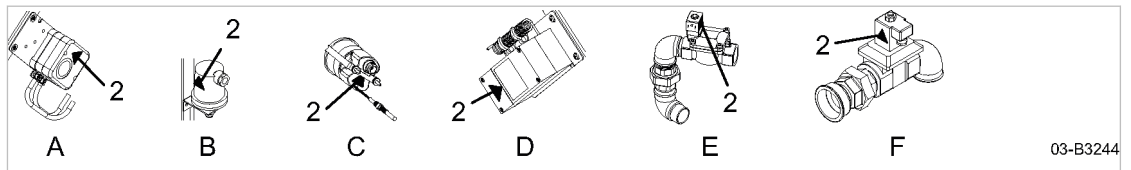

Fig. 4 Safety sign location, electronically actuated options

- A** Filter differential pressure switch (Option F5)
- B** Pressure switch (Option C9)
- C** Temperature display with switching point (Option C13)
- D** Thermostat (Option C19)
- E** AFM 4 (Option C11)
- F** AFM 5 (Option C11)

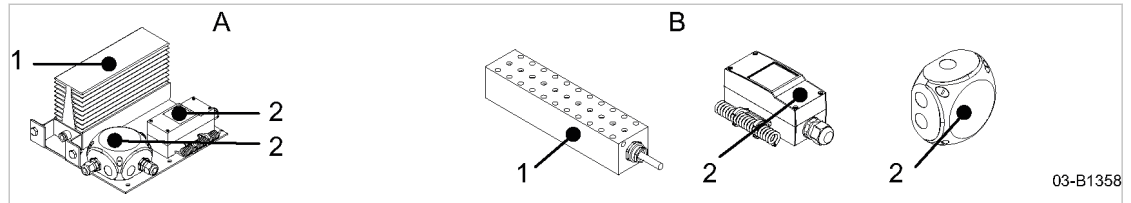

Fig. 5 Safety sign position, standstill heater, Option H2

- (A) BB 52 C pr
- (B) BB 69 C pr, BB 89 C pr

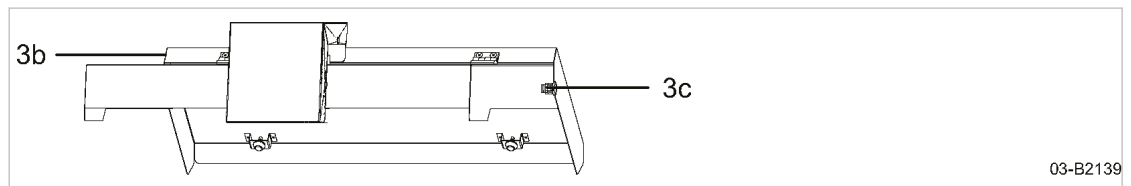





Fig. 6 BB 69 C pr, BB 89 C pr Safety sign location, weather protection, Option H3

Location	Symbol	Meaning
1 1a 1b 1c 1d		Hot surface can cause burns! ▶ Let the machine cool down. ▶ Wear long-sleeved garments (not synthetics such as polyester) and protective gloves.
2 2a 2b		Danger of fatal injury from touching electrically live components! ▶ Switch off and lock out the power supply disconnecting device and check that no voltage is present.
3		Rotating rotors! Risk of serious lacerations or even severing of extremities (fingers) from rotating components. ▶ Operate the machine only when a connection is made to the inlet port. ▶ Switch off and lock out the power disconnecting device and check that no voltage is present before opening any machine enclosure or guard.
3b 3c		Injuries (to the hands in particular) due to shearing effects. ▶ Carefully close the flap in the weather protection roof (Option H3). ▶ Always wear protective gloves.
8		Personal injury or damage to the machine by incorrect operation! ▶ Read and understand the service manual and all safety signs before switching on this machine.
11a 11b		Hot gas! Burning, from contact with hot gasses. ▶ Do not enter danger zone. ▶ Wear long-sleeved garments (not synthetics such as polyester) and protective gloves.
12a		Serious injury or death can result from loosening or opening component that is under pressure and heavily spring loaded! ▶ Do not open or dismantle the valve. ▶ Contact an authorized KAESER SERVICE representative if a fault occurs.

Location	Symbol	Meaning
13a		Serious injury or death can result from loosening or opening component under pressure! > Depressurize all pressurized components and enclosures. > Ensure the machine remains depressurized. > Check that machine is depressurized.
14		Severe injury could result from touching the v-belt drive while it is rotating! > Switch off and lock out the power supply disconnecting device and check that no voltage is present.
15		Injury and/or contamination can result from breathing compressed air! Contamination of food can result from using untreated compressed air for food processing! > Never breathe untreated compressed air. > Air from this compressor must meet OSHA 29CFR1910.134 and FDA 21CFR178.3570 standards, if used for breathing or food processing. Use proper compressed air treatment.
16		Noise due to opened service panel of the sound enclosure (Option H12)! > Hearing may be damaged. > Wear hearing protection.

Tab. 33 Safety signs

3.9 In emergency

3.9.1 Correct fire fighting

Suitable extinguishing agents

- Foam
- Carbon dioxide
- Sand or dirt

Unsuitable or unsafe extinguishing agents

- Strong jet of water
1. Keep calm.
 2. Give the alarm.
 3. Switch off the power supply disconnecting device, if possible.
 4. Move to safety.
 - Warn persons in danger.
 - Help incapacitated persons.
 - Close the doors.
 5. Try to extinguish the fire if you have the skill to do so.

3.9.2 Remove lubricating oil from the skin.

- Eye contact:
Rinse eyes thoroughly with lukewarm water and seek medical assistance.
- Skin contact:
Wash off immediately.

3.10 Environmental protection

- Store and dispose of operating materials and replaced parts in accordance with local environmental protection regulations.
- Observe national regulations.
This applies particularly to parts contaminated with lubricating oil.



- Do not allow lubricating oil to escape to the environment or into the sewage system.

3.11 Warranty

This operator manual contains no independent warranty commitment. Our general terms and conditions of business apply with regard to warranty.

A condition of our warranty is that the machine is used for the purpose for which it is intended under the conditions specified.

Due to the multitude applications for which the machine is suitable the obligation lies with the user to determine its suitability for his specific application.

In addition, we accept no warranty obligation for:

- the use of unsuitable parts or operating materials,
- unauthorized modifications,
- incorrect maintenance,
- incorrect repair.

Correct maintenance and repair includes the use of original spare parts and operating materials.

- Obtain confirmation from KAESER that your specific operating conditions are suitable.

4 Design and Function

4.1 Machine

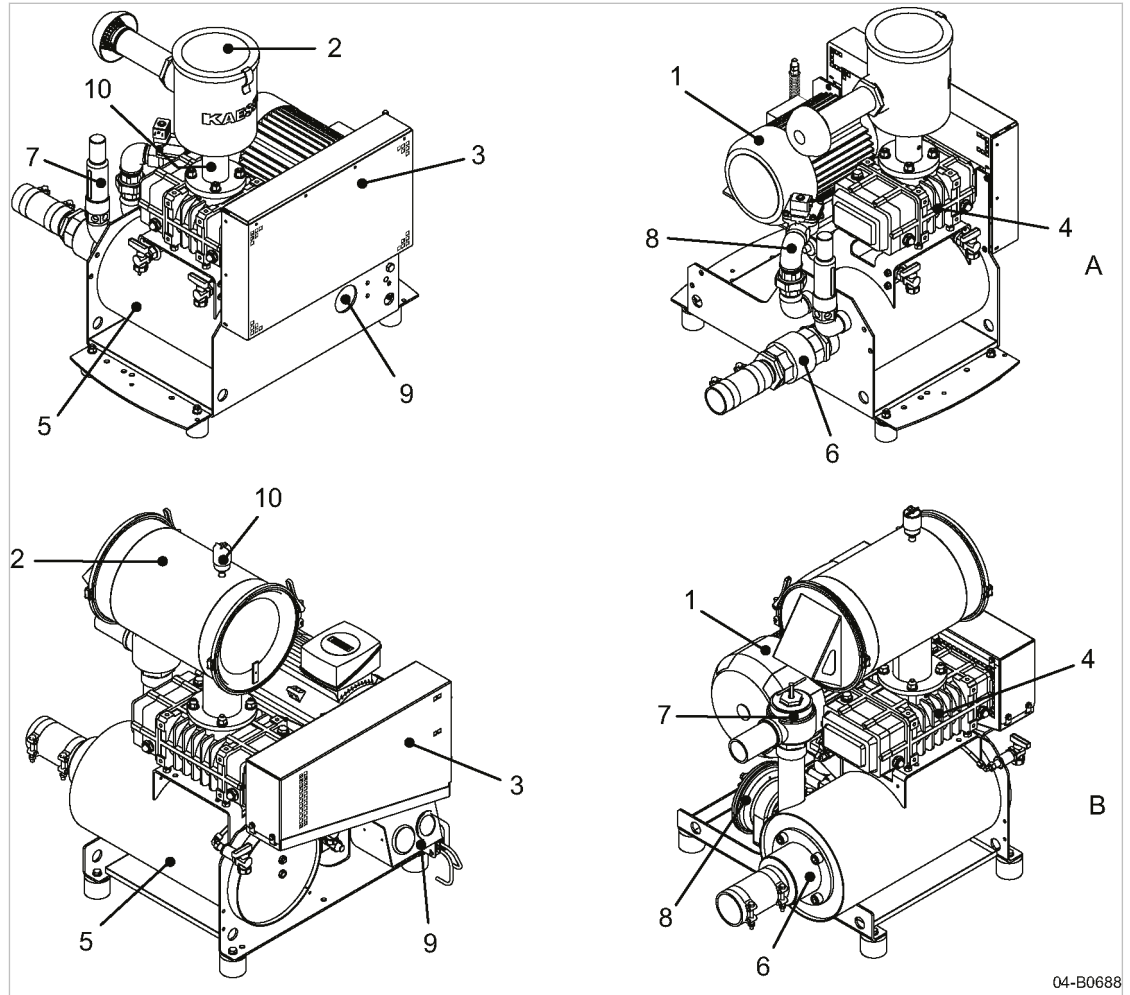

Fig. 7 Machine

- | | | | |
|-----|------------------------|------|--|
| (A) | BB 52 C pr | (5) | Outlet silencer |
| (B) | BB 69 C pr, BB 89 C pr | (6) | Check valve (option G1) |
| (1) | Drive motor | (7) | Safety relief valve |
| (2) | Inlet silencer | (8) | Unloaded start valve or unloaded start valve with regulating valve (Option C11, C18) |
| (3) | Belt guard | (9) | Display (option) |
| (4) | Blower block | (10) | Filter maintenance indicator |

The drive motor (1) drives the blower block (4) via belts.

Air is drawn into the inlet silencer (2) through a filter where it is cleaned.

The air is then compressed in the blower block and transported vertically into the outlet silencer (5), where this process forces pressure build-up.

4.2 Blower block

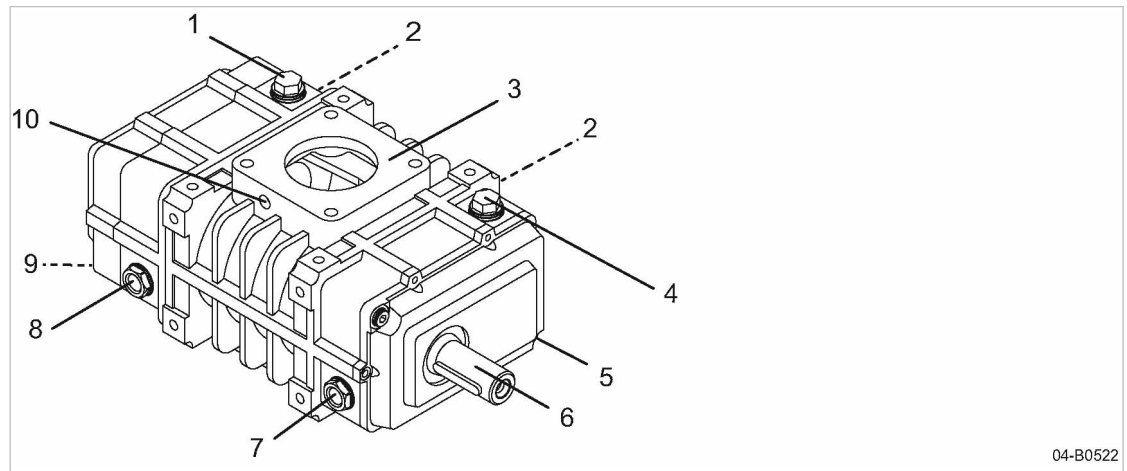

Fig. 8 Blower block

- | | |
|----------------------------------|--|
| ① Gear-end oil inlet | ⑥ Drive shaft |
| ② Side gas drainage (closed) | ⑦ Drive-end oil sight glass |
| ③ Flange connection (both sides) | ⑧ Gear-end oil sight glass |
| ④ Drive-end oil inlet | ⑨ Gear-end oil drain |
| ⑤ Drive-end oil drain | ⑩ Connection for measuring instrument (both sides) |

A pair of rotors with intermeshing lobes turn in opposite directions within a casing. The rotors are synchronized by timing gears on one end. Air in the block inlet is trapped between the rotor lobes and the casing and moved round to the discharge port.

As there is no contact between the rotors themselves and the casing, oil film lubrication is not required.

4.3 Safety relief valve

The safety relief valve protects the pressure system included within the scope of delivery against an impermissible pressure rise. It is set at the factory.

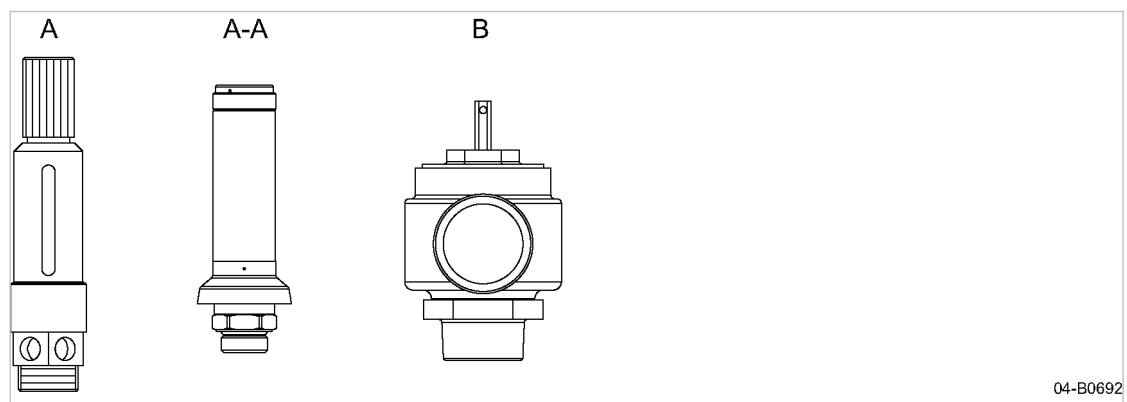

Fig. 9 Safety relief valve

- | |
|-------------------------------------|
| Ⓐ Variant A, BB 52 C pr |
| ⒶⒶ Variant AA, BB 52 C pr |
| Ⓑ Variant B, BB 69 C pr, BB 89 C pr |

4.4 Safety devices

The following safety devices are provided and may not be modified in any way.

- Safety relief valve:
The safety relief valve protects the machine from excessive pressure build-up. It is factory set.
- Covers over moving parts and electrical connections:
These protect against accidental contact.

4.5 Compensator

The compensator functions as follows:

- Inlet and outlet connections to silencers and accessories,
- Isolates the machine vibrations from the air pipeline.

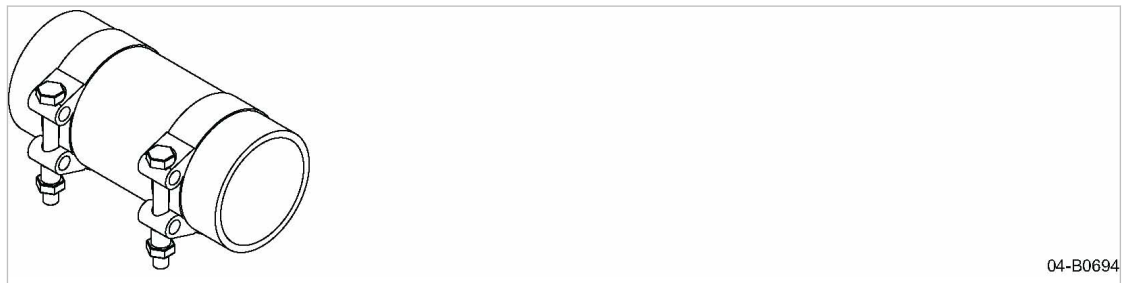

04-B0694

Fig. 10 Compensator

4.6 Filter maintenance indicator

The maintenance indicator shows when the filter needs maintenance. When the filter becomes clogged and flow resistance rises to a set point, the maintenance signal is given.

4.7 Pressure gauge

The pressure gauge shows the pressure in the blower block discharge port.

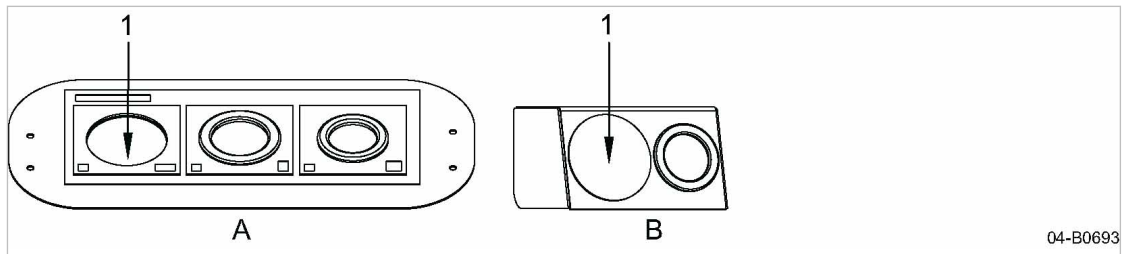

04-B0693

Fig. 11 Location of the pressure gauge

- (A) Machine with sound enclosure
- (B) Machine without sound enclosure
- (1) Pressure gauge

4.8 Floating relay contacts

Potential-free contacts for the transmission of messages are provided.

For information on location, loading capacity, and message type please see electrical wiring diagrams options in Chapter 13.5.



If the floating relay contacts are connected to an external voltage source, voltage may be present even when the machine is isolated from the power supply.

4.9 Options

The options available for your machine are described below.

4.9.1 Option C9

Pressure switch

The pressure switch sends a signal when the set pressure is exceeded.



The pressure switch is factory set according to the customer's specification. In other cases it must be set according to the application.

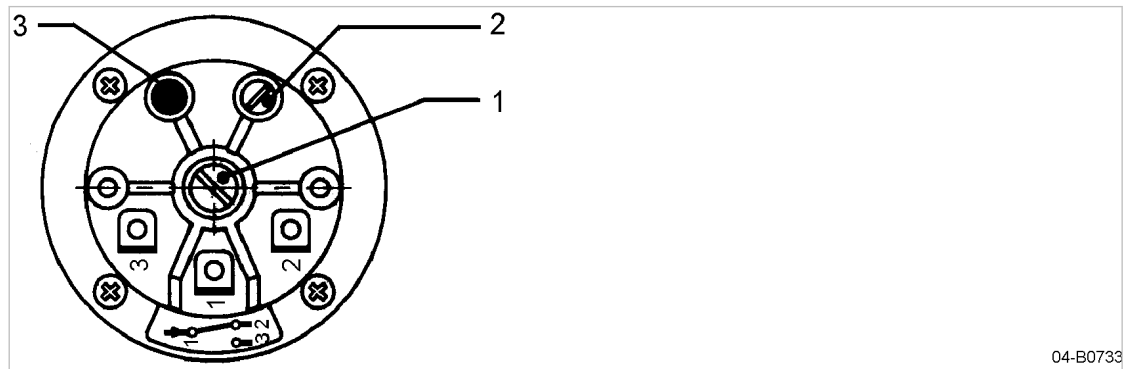

04-B0733

Fig. 12 Pressure switch

- ① Switching point adjusting screw
- ② Switching differential adjusting screw
- ③ Screw sealed with a protective coating

The switching point can be adjusted by the screw ① while the machine is running.

Fine adjustment and switching differential is set with the adjusting screw ②.



The screw ③ is sealed with a protective coating. It is not to be adjusted.

4.9.2 Option C10

Speed monitor

The speed monitor measures the rotational speed of the blower block.

4.9.3 Option C11
Unloaded start valve

4.9.3.1 AFM 4, AFM 5

AFM 4 and AFM 5 open the discharge line from the machine to the atmosphere for unloaded starting.

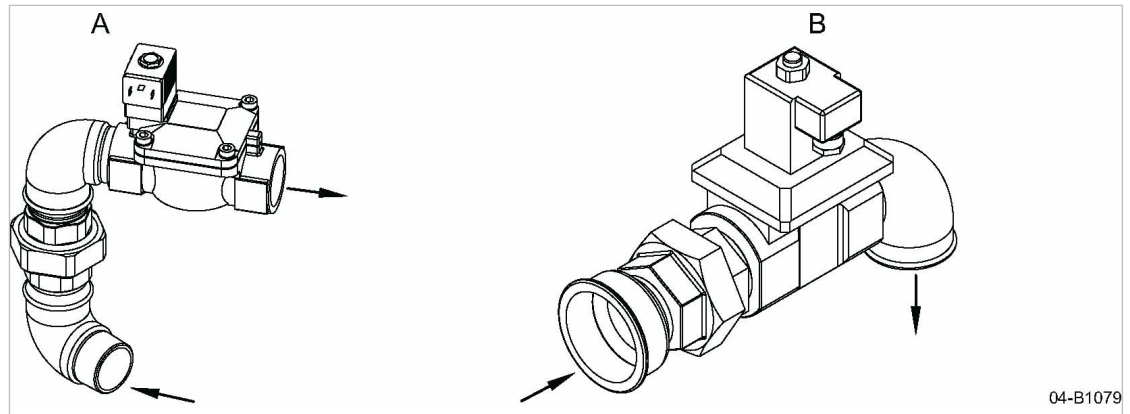

Fig. 13 Unloaded start valve: AFM 4, AFM 5

- A** AFM 4
- B** AFM 5

Functional description

The unloaded start valve is de-energized (closed) when the machine is switched off.

When the machine is switched on and the motor is in star (Y) phase, the unloaded start valve is energized (opens). Air discharged from the block is blown out to atmosphere.

When the motor switches to delta (Δ), the unloaded start valve is de-energized and closes.

4.9.3.2 AFE 15

AFE 15 prevents the machine starting against a load in the star-delta phase. The valve closes when the motor starter switches from star (Y) to delta (Δ).

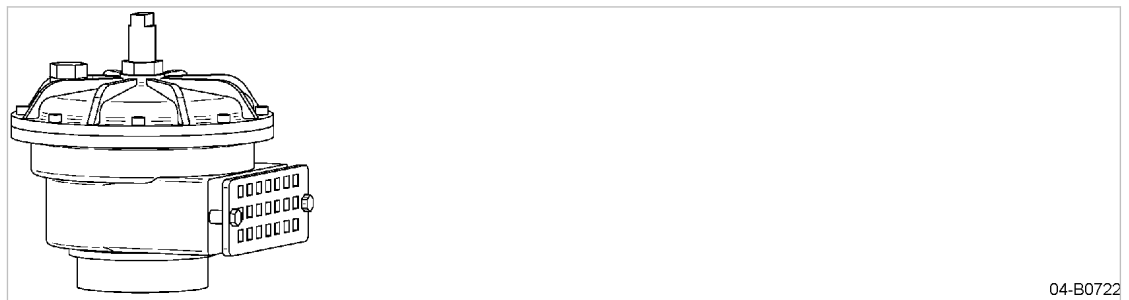

Fig. 14 Unloaded start valve: AFE 15



The unloaded start valve is factory set.

Functional description

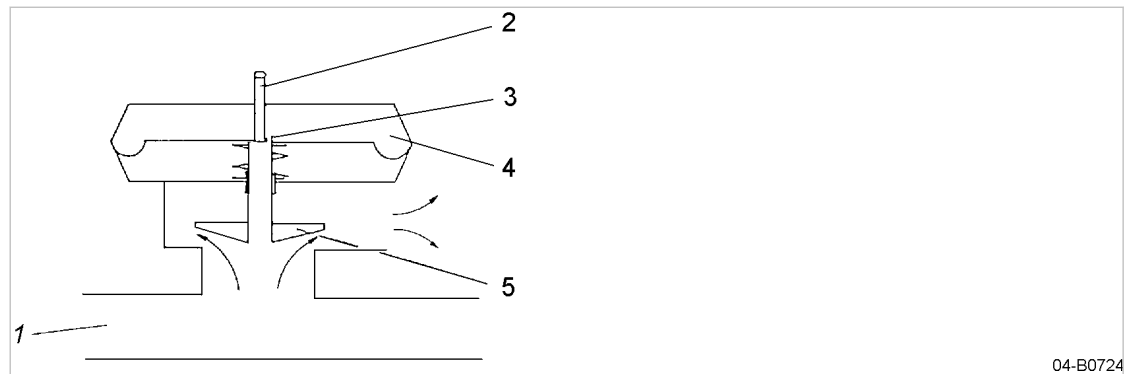

Fig. 15 Diagram of the unloaded start valve: AFE 15

- | | |
|-------------------|---------------------|
| ① Air network | ④ Diaphragm chamber |
| ② Adjusting screw | ⑤ Valve cone |
| ③ Nozzle | |

When the machine is shut down the valve cone ⑤ is open.

When the machine is started, air passes through the blow-off aperture to atmosphere.

Screwing in the adjusting screw ② reduces the gap between the valve cone ⑤ and its seating so that it closes at a lower flow rate.

(1.45 psi pressure is needed in the network to close the valve cone ⑤.)

Back pressure acts through the nozzle ③ into the diaphragm chamber ④ to close the valve cone. The closing time is influenced by the adjusting screw ② changing the position of the valve cone.

Changing the closing time with the adjusting screw:

- Clockwise - shorter closing time
- Counterclockwise - longer closing time

**4.9.4 Option C13
Temperature gauge switch**

The gauge shows the temperature in the block discharge port and has a floating relay changeover contact that can be set to switch at a selected temperature.



The switching point is factory set to 293 °F.

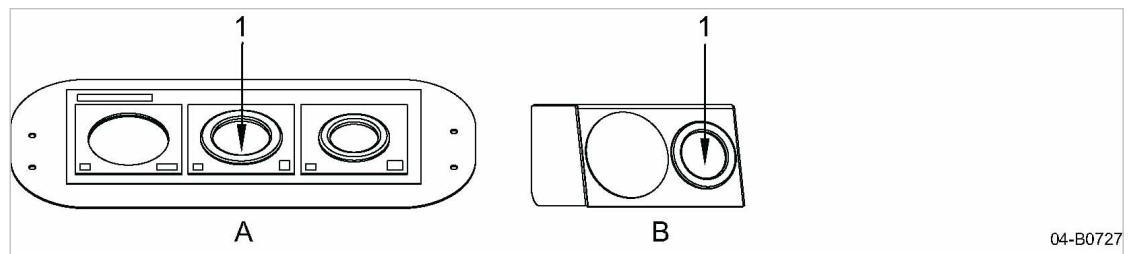

Fig. 16 Location of the temperature gauge

- | |
|--|
| Ⓐ Display: Machine with sound enclosure (Option H12) |
| Ⓑ Display: Machine without sound enclosure |
| ① Temperature gauge |

Setting instructions

The switching point can be adjusted by means of the screw beneath the protective cover on the front plate.

Possible adjustment for working conditions on site:

- Block discharge temperature lower than 293 °F
 - If the average block discharge temperature is significantly lower than 293 °F, the gauge switching point can be adjusted down.
The recommended switching point is the average block discharge temperature plus +15 K.
- Block discharge temperature higher than 293°F
 - If the average block discharge temperature is near to or higher than 293 °F, adjust the switching point upward.
The maximum permissible value is 311 °F.

**4.9.5 Option C14
Pressure sensor**

The sensor measures the actual block discharge pressure.

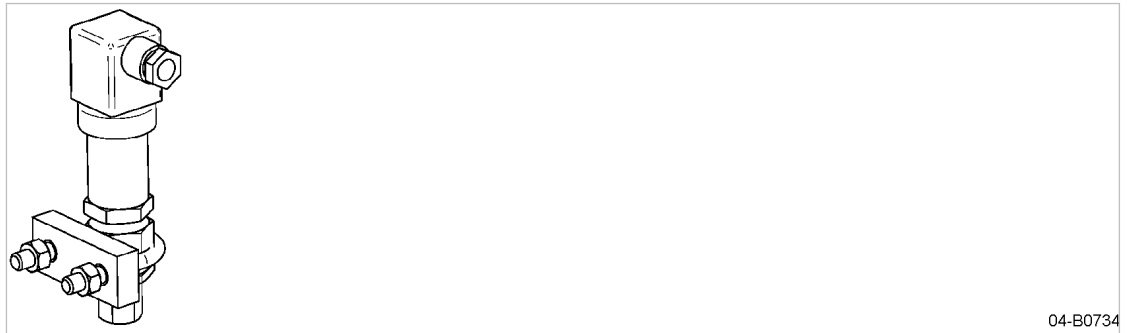

04-B0734

Fig. 17 Pressure sensor

**4.9.6 Option C18
Unloaded start valve with regulating valve**

The unloaded start valve with regulating valve is a medium-controlled valve with the following functions:

- Unloaded starting
- Pressure regulating during operation

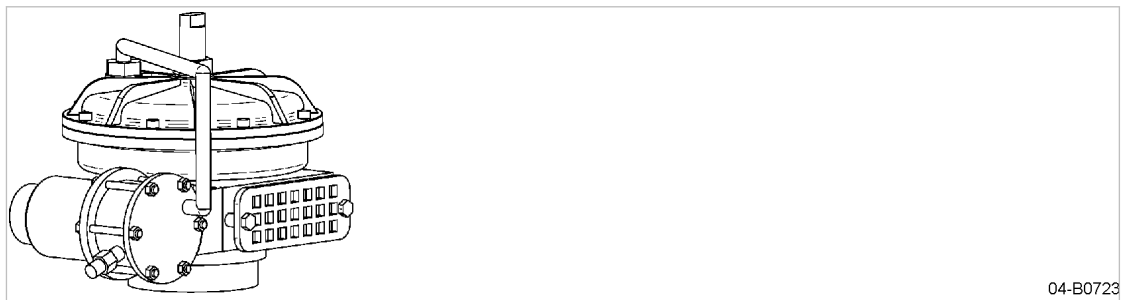

04-B0723

Fig. 18 Unloaded start valve with regulating valve

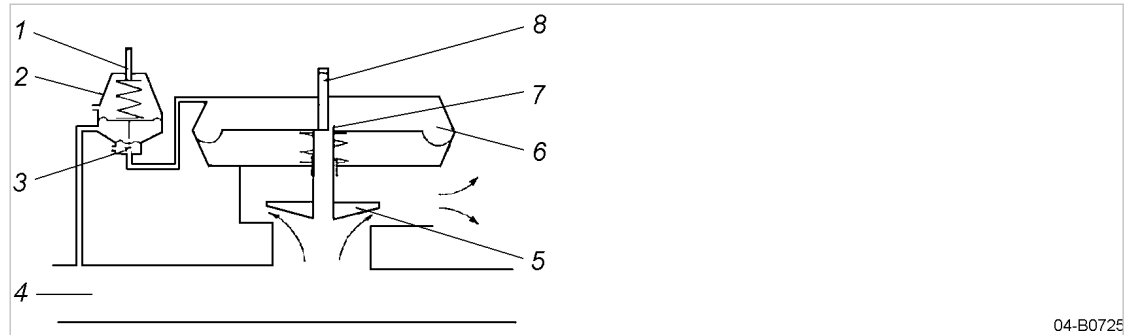

Fig. 19 Diagram of the unloaded start valve with regulating valve

- | | | | |
|---|-----------------------|---|-------------------|
| ① | Adjusting screw | ⑤ | Valve cone |
| ② | Control air regulator | ⑥ | Diaphragm chamber |
| ③ | Valve cone | ⑦ | Nozzle |
| ④ | Air network | ⑧ | Adjusting screw |

Unloaded starting

When the machine is stopped the valve cone ⑤ is open and valve cone ③ closed. When the machine is started, air flows over the valve cone ⑤ and is blown off to atmosphere. The pressure build-up in the air network ④ is transmitted through the hollow spindle and nozzle ⑦ into the upper diaphragm chamber ⑥. The resulting pressure on the diaphragm closes the valve cone ⑤.

Changing the closing time:

The valve closing time can be adjusted by changing the nozzle ⑦ and turning the adjusting screw ⑧.

- Clockwise: shorter closing time
- Counterclockwise: longer closing time

The unloaded start function only works if the pressure in the air network ④ reaches at least 1.45 psig.

Overflow regulation



The control air regulator is set to atmospheric pressure.

After starting, the network pressure and the pressure on the control air regulator ② rises. As soon as the set network pressure is reached the valve cone ③ opens. Pressure in the upper diaphragm chamber ⑥ bleeds off to atmosphere and the valve cone ⑤ opens.

The set network pressure is kept constant.

Changing the pressure setting:

Remove the rubber cap from the control regulator to change network pressure. Undo the locknut and adjust the screw with a screwdriver.

- Clockwise: lower pressure
- Counterclockwise: higher pressure

Lock the screw in position after adjusting and replace the rubber cap.

**4.9.7 Option C19, H12
Thermostat**

The thermostat controls the temperature within the sound enclosure. It consists of a temperature sensor with a floating relay change-over contact.



The switching point is factory set to 140°F.

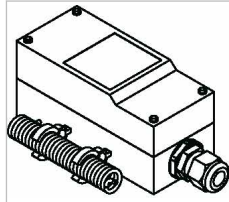

04-B0731

Fig. 20 Thermostat

**4.9.8 Option F5
Filter pressure differential switch**

The filter pressure differential switch monitors contamination of the intake filter.

The switch is triggered by pressure differential. Falling below or rising above the set value causes the current flow to switch on, switch off or changeover according to how the switch is wired.

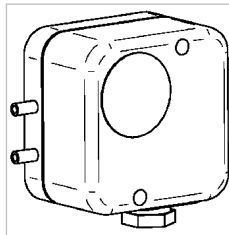

04-B0776

Fig. 21 Filter pressure differential switch

Pressure connection diagram

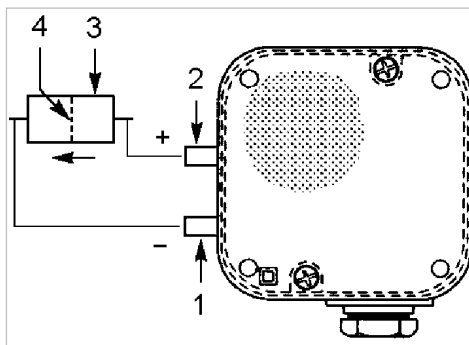

04-B0736

Fig. 22 Pressure connection to the filter pressure differential switch

- | | |
|------------------------------|------------------|
| ① Low pressure connection | ③ Inlet silencer |
| ② Higher pressure connection | ④ Filter |

Switching function

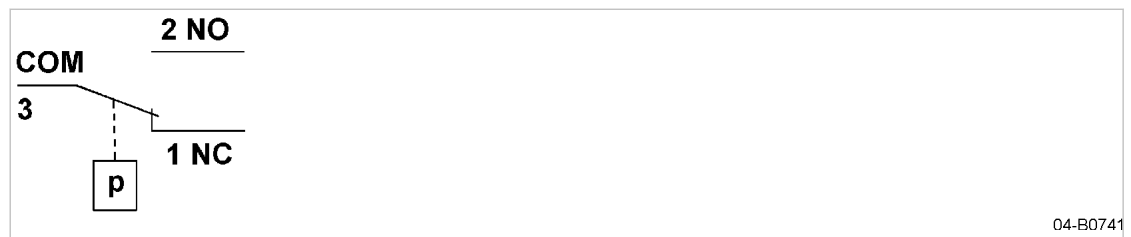

Fig. 23 Filter pressure differential switch function

Switching with rising pressure:

- 1 NC opens
- 2 NO closes

Switching with falling pressure:

- 1 NC closes
- 2 NO opens

**4.9.9 Option G1
Check valve**

The check valve prevents a reversal of the normal air flow direction.
The valve is closed when the machine is at standstill.

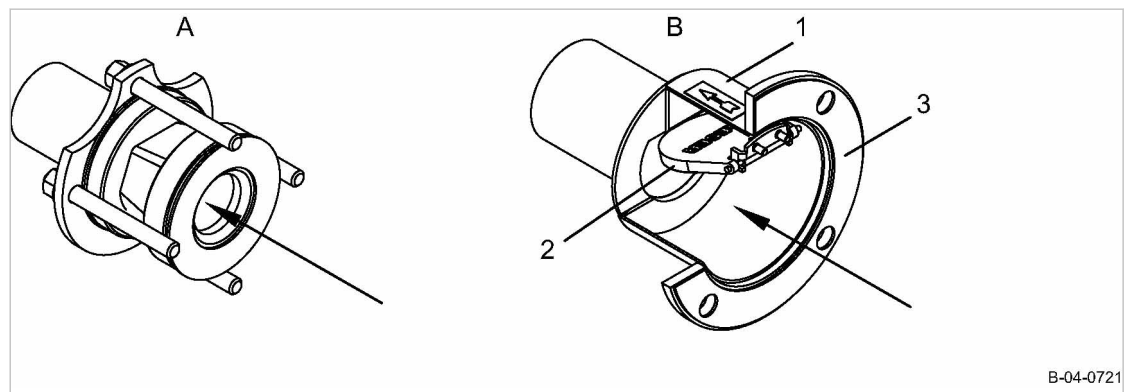

Fig. 24 Check valve

- | | |
|--|--|
| <p>(A) BB 52 C pr</p> <p>(B) BB 69 C pr, BB 89 C pr</p> <p>(1) Housing</p> | <p>(2) Closing mechanism</p> <p>(3) Gasket</p> |
|--|--|

**4.9.10 Option H2, H12
Auxiliary heating**

The auxiliary heating has the following functions:

- Prevents condensation forming on the machine in climates of high humidity.
- Pre-warms the machine when ambient temperatures are below 23°F.

The heating is designed to raise the machine temperature by about 59°F.



The thermostat switching point is factory set to 41°F.

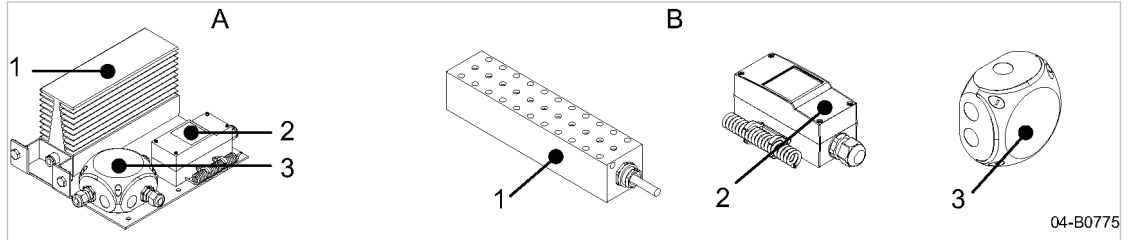

Fig. 25 Auxiliary heating

- | | | | |
|-----|------------------------|-----|--------------|
| (A) | BB 52 C pr | (2) | Thermostat |
| (B) | BB 69 C pr, BB 89 C pr | (3) | Terminal box |
| (1) | Radiator | | |

4.9.11 Option H3, H12 Outdoor installation

BB 69 C pr, BB 89 C pr

The sound enclosure (Option H12) is fitted with a weather protection roof.

Should the machine be installed outdoors, the instruments and the parts of the sound enclosure within the cover area are protected against direct sunlight, rain, wind and snow.

Further information Information regarding the maximum permissible snow and wind loads can be found in chapter 2.13.11

4.9.12 Option H11 Piped inlet

Air is drawn into the block through the inlet silencer.

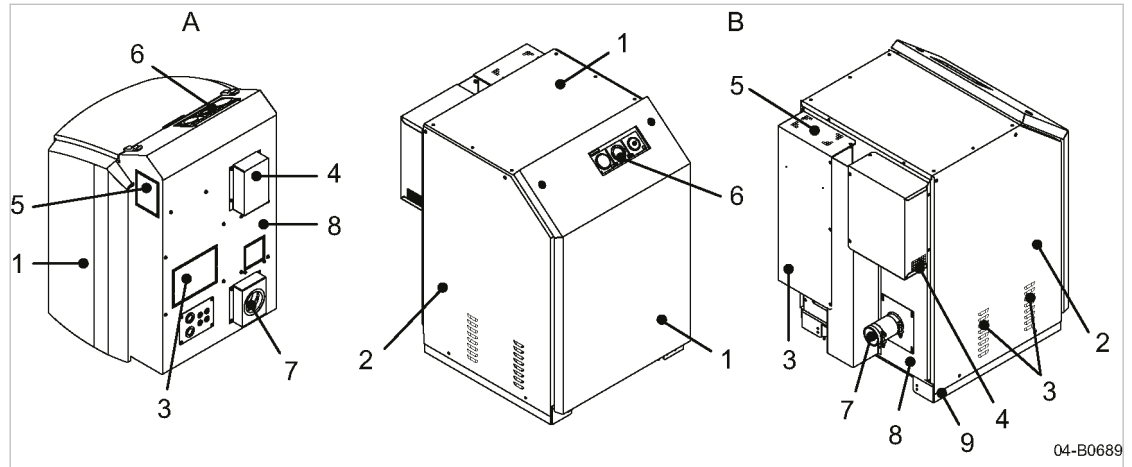
**4.9.13 Option H12
 Sound enclosure**

Fig. 26 Sound enclosure

- | | |
|-----------------------------------|-------------------------------------|
| (A) BB 52 C pr | (5) Cooling air outlet |
| (B) BB 69 C pr, BB 89 C pr | (6) Display (optional) |
| (1) Removable panel | (7) Pressure line connection |
| (2) Side panel | (8) Back plate |
| (3) Cooling air inlet | (9) Frame |
| (4) Intake air inlet | |

The motor fan draws cooling air through the cooling air inlet **(3)** into the sound enclosure to cool the drive motor and the machine.

Cooling air flow is supplemented by a fan within the sound enclosure. The warm air is blown out to protect the machine from overheating.

Air to be compressed is drawn in through a separate intake air inlet **(4)**. This ensures that only air at ambient temperature is compressed.

The sound enclosure has a removable panel **(1)**.

BB 52 C pr: Open the snap fasteners.

BB 69 C pr, BB 89 C pr: Use the supplied key to release the latches.

The sound enclosure has several functions when it is closed:

- Sound insulation
- Airflow control
- Protection against contact with components

The sound enclosure is not suitable for the following uses:

- Persons walking, standing, or sitting on the machine.
- Use as a resting place or storage of any kind of load.

5 Installation and Operating Conditions

5.1 Ensuring safety

The conditions in which the machine is installed and operated have a decisive impact on safety. Warning instructions are located before a potentially dangerous task.



Disregard of warning instructions can cause serious injuries!

Complying with safety instructions

Disregard of safety warnings can cause unforeseeable dangers!

- Strictly forbid fire, open flame and smoking.
- If welding is carried out on or near the machine, take adequate measures to prevent sparks or heat from igniting oil vapors or parts of the machine.
- Do not store flammable material in the vicinity of the machine.
- The machine is not explosion-proof!
Do not operate in areas in which specific requirements with regard to explosion protection are in force.
- Ensure sufficient and suitable lighting such that the display can be read and work carried out comfortably and safely.
- Keep suitable fire extinguishing agents ready for use.
- Comply with the permissible ambient and intake conditions.
- Ensure the correct composition of the intake air:
 - Clean with no damaging contaminants (e.g., dust, fibers, fine sand).
 - Free of explosive or chemically unstable gases or vapors.
 - Free of acid/alkaline forming substances, particularly ammonia, chlorine or hydrogen sulfide.

Noise

The sound enclosure absorbs and reduces the machine noise to a comfortable level. This function will be effective only if the sound enclosure is closed.

- If necessary, wear hearing protection or take hearing protection measures on-site.

5.2 Installation conditions

5.2.1 Determining installation location and clearances

The machine is intended for installation in a suitable machine room. Information regarding wall clearances and ventilation is given below.



The specified wall clearances are recommendations and ensure unhindered access to all machine parts.

- In the event that these cannot be complied with, please consult KAESER for further advice.

Precondition The floor must be level, firm, and capable of bearing the weight of the machine. No special foundations are necessary.

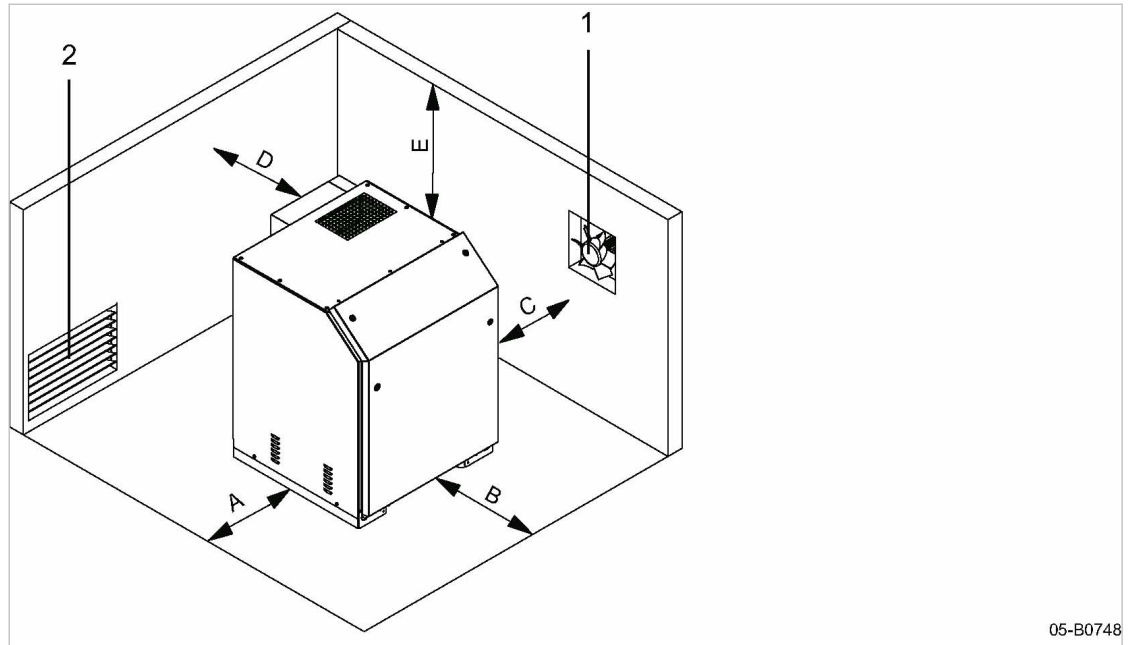

Fig. 27 Recommended positioning of the machine, minimum dimensions [in.]

- | | |
|-----------------|-----------------------|
| (A) 1.6 or 27.6 | (E) 27.6 |
| (B) 32.0 | (1) Exhaust fan |
| (C) 1.6 or 27.6 | (2) Air inlet opening |
| (D) 27.6 | |

➤ Determine distance (A) and (C) according to the following criteria:

Individual machine installation	Installation beside another machine
Distance (A) or (C) must be at least 27.6 in.. Version 1: (A) = 1.6 in. and (C) = 27.6 in. Version 2: (A) = 27.6 in. and (C) = 1.6 in.	Between machines: Distance (A) and (C) must be at least 1.6 in.. At the end of a machine line: Distance (A) or (C) must be at least 27.6 in.. Version 1: (A) = 1.6 in. and (C) = 27.6 in. Version 2: (A) = 27.6 in. and (C) = 1.6 in.

Tab. 34 Recommended installation, minimum dimensions

- If the ambient temperature is too low: Heat the machine room sufficiently or install a standstill heater.
- Ensure accessibility so that all work on the machine can be carried out hazard-free and without obstruction.
- Do not position the machine in the hot exhaust air flow from other machines.
- When installing multiple machines, ensure that all inlet and exhaust air openings are arranged on one side.
- If installed outdoors, protect the machine against frost, direct sunlight, dust and rain.

5.2.2 Ensuring adequate ventilation



If there is insufficient inlet air, negative pressure can occur in the machine room.

- Ensure that the flow rate of fresh air is at least the same as the flow rate taken in by the machine and exhaust fan from the machine room.
- Ensure a sufficient supply of oxygen for persons in the machine room.
- Ensure that the machine and exhaust fan can only be operated when the air inlet aperture is open.
- Keep the inlet and exhaust openings free from obstructions so that the cooling air can flow freely through the machine room.

5.3 Option H3, H12 Outdoor installation

- **BB 52 C pr**
Should the machine be installed outdoors, the joints on the sound enclosure (Option H12) are sealed with silicone.
The instruments are protected against direct sunlight, rain, wind and snow.
Separate insulation for the intake air duct protects against moisture.
 - **BB 69 C pr, BB 89 C pr**
The sound enclosure (Option H12) is fitted with a weather protection roof.
Should the machine be installed outdoors, the instruments and the parts of the sound enclosure within the cover area are protected against direct sunlight, rain, wind and snow.
Separate insulation for the intake air duct protects against moisture.
1. **⚠ CAUTION** *Risk of accident from falling snow and/or ice loads!*
 - *Remove any snow and/or ice from the machine before commissioning*
 2. Remove snow and/or ice with caution.

6 Installation

6.1 Ensuring safety

Follow these instructions to ensure safe installation.

Warning instructions are provided prior to any potentially dangerous task.



Disregard of warning instructions can result in life-threatening injuries!

Observe safety instructions

Ignoring safety instructions can result in unforeseen dangers.

- Follow the instructions in chapter 3 "Safety and Responsibility".
- Installation work must be carried out by authorized personnel only!
- Ensure that no personnel are working on the machine.
- Ensure that all cover panels are closed.

Working on live components

Touching live components can result in electric shocks, burns or death.

- Work on electrical equipment may only be carried out by authorized and certified electricians.
- Switch off the power supply disconnecting device, lock out / tag out the device, verify the absence of all voltage.
- Check that any floating contacts are free from voltage.

Working on the pressure system

Compressed air is stored energy. Uncontrolled release of this energy can cause serious injury or death. The following safety instructions relate to any work on components that might be pressurized.

- Switch off the power supply disconnecting device, lock out / tag out the device, verify the absence of all voltage.
- Close shut-off valves or otherwise isolate the machine from the compressed air network so as to ensure that no compressed air can flow back into the machine.
- Fully vent all pressurized components and enclosures.
- Do not open or dismantle any valves.

Working on the drive system

Touching live components can result in electric shocks, burns or death.

Touching the fan wheel or the belt drive while the machine is running can result in serious injury.

- Switch off the power supply disconnecting device, secure it against being switched on again, verify the absence of all voltage.

- Do not open any of the cover panels while the machine is switched on.
- If full protection is only provided when the machine is completely installed, then in all other phases of the machine's life-cycle temporary protective devices (e.g. covers) must be fitted, in order to guarantee that parts of the body cannot reach or be caught/sucked in by the rotary lobes.

Further information Information regarding authorized personnel can be found in chapter 3.4.2.
Information regarding dangers and the avoidance thereof can be found in chapter 3.5.

6.2 Reporting transport damage

1. Check the machine for visible and hidden transport damage.
2. Inform the carrier and the manufacturer in writing of any damage without delay.

6.3 Anchoring the machine

The machine may be anchored to the floor.

The following anchoring elements are shipped with the machine:

Foundation bolts for machines without sound enclosure.

Foundation bolts and angle brackets for machines with sound enclosure.

- Use the anchoring elements to anchor the machine without stress.

Further information Details of the fixing holes are contained in the dimensional drawing in chapter 13.2.

6.4 Connecting the machine to the power supply

Precondition The power supply disconnecting device is switched off, lock out and tag out the device, the absence of any voltage has been verified.

The tolerance limits of the power supply are within the permissible tolerance limits of the rated machine voltage.

Option C32, operation under frequency control: The voltage in the intermediate circuit capacitors of the frequency converter is reduced.

1. The power supply must only be connected by authorized installation personnel or an authorized electrician.
2. Carry out safety measures as stipulated in relevant regulations and in national accident prevention regulations. In addition, observe the regulations of the local electricity supplier.
3. Select supply cable conductor cross sections and fusing in accordance with machine power and as per local regulations.
4. Test the overcurrent protective device to ensure that the time it takes to shut down in response to a fault is within the permitted limit.
5. The user is required to fit the machine with a lockable power supply disconnecting device which must comply with the requirements of EN 60204-1: 2018. 5.3.
This could be, for example, a load disconnect switch with fused input. If a circuit breaker is used it must be suitable for the motor starting characteristics.

6. Connect the drive motor to the power supply in accordance with the applicable connection diagram.
See connection diagram in chapter 13.4.
7. The user's safety devices must be correctly connected to the machine's electrical system by a qualified person.
8. Option C32, operation with frequency converter: Please refer to - and observe - all documentation regarding operation of, and work on, the frequency converter.
9. **⚠ DANGER** *Danger of fatal injury from electric shock!*
 - *Switch off and lock out/tag out the power supply disconnecting device and verify the absence of voltage.*
 - *When working with the frequency converter: Wait at least 5 minutes for dangerous voltages to subside.*
10. Connect the machine to the power supply.
11. Properly close openings, cable glands, etc.



The machine can be operated at full power at the rated voltage with a tolerance of $\pm 5\%$.

6.4.1 Option C32 For frequency control



If the machine delivered by KAESER includes the frequency converter, the regulation behavior and operating mode of the frequency converter will be preset.

- Adapt and optimize the actual properties to the customer system on-site.

Comply with the following provisions if you operate machines with a frequency converter:

- Operate the machine only within its performance limits and under the permitted ambient conditions.
- The frequency converter must be suitable for the operation of a working machine with constant torque. Models with squared torque may not be used.
- Drive motor rated power ≤ 75 hp:
To avoid bearing damage at the drive motor, install components for magnetic shielding at the frequency converter's phase wire output ends (e.g., rings with high permeability).
- When operating the machine with frequency converter, the drive motor must be designed as follows:
 - Voltage $< 500\text{ V} \geq 100$ hp:
Standard winding and isolated bearing or bearing shield at the control side, regardless of the model.
 - Voltage $\geq 500\text{ V} < 100$ hp:
Enhanced winding isolation, standard bearing, regardless of the model.
 - Voltage $\geq 500\text{ V} \geq 100$ hp:
Enhanced winding isolation and isolated bearing or bearing shield at the drive and the control side, regardless of the model.
- Frequency converters providing a lower initial voltage than the rated motor voltage will cause an increased power consumption and heat development in the drive motor. This results in a reduced nominal motor power that can be utilized and thus a decrease in the machine's regulating range. To avoid damage to the drive motor, please consult with the manufacturer of the frequency converter.
- Use a frequency converter with IGBT transistors.

- The speed change should be approx. 5 Hz per second. This value applies also for the starting ramp from standstill to reaching minimum frequency. Changing the settings, either slower or faster, may be possible after verification by an authorized KAESER service representative.
- The frequency converter may be switched onto a motor in standstill only, in order to avoid malfunctions.
- Upon deactivation of the frequency converter, it must be impossible to reactivate it until after complete machine standstill.
- For a shut-down in the event of a malfunction, integrate the following devices in the user's controller:
 - PTC resistor for monitoring the winding temperature of the drive motor.
 - Thermostat for monitoring the blower block discharge temperature.
- For safety-technical reasons, an automatic restart of the machine is not permitted and must be fully deactivated when parametrizing the frequency converter.
- The maximum conductor length between the output of the frequency converter and drive motor is 98 ft. Longer conductors may be possible upon verification by an authorized KAESER service representative.
- Only shielded conductors may be used to connect the machine to ensure an EMC compliant connection and machine operation.
 - Do not twist the braided shield of these conductors. The braided shield must be generously spread two-sided across the ground potential.
 - Use only EMC shield clamps or EMC-compliant screwed cable glands.
 - This also applies to other connecting cables, such as the thermistor sensors (PTC) of the drive motor.

Further information Consult with an authorized KAESER service representative to determine an appropriate frequency converter.

6.4.2 Option H3, H12 Outdoor installation

- Install suitable protection against lightning.

6.5 Making the compressed air connection

Material Torque wrench

Precondition The machine is factory assembled up to the point of connection to the discharge silencer. The air main is at atmospheric pressure.

WARNING

Serious injury or death can result from loosening or opening components under pressure!

- *Depressurize all pressurized components and enclosures.*



If the system has a tendency for air/gas under pressure to flow back to the machine when it is stopped, a non-return device must be installed to allow for unloaded starting of the machine.

- Consult KAESER on a suitable check valve and expert installation.

1. Use a flexible connector (compensator) to connect the user's pipeline and install, complying with the torques specified below:

Connection	Torque [lbf-ft]	
	BB 52 C pr	BB 69 C pr, BB 89 C pr
Compressor with hose clamps	7.4	14.8
Compressor with screwed joint M20*	—	—

* Manually tighten screws equally, pretension crosswise at 37 lbf-ft and subsequently retighten crosswise with torque according to table.

Tab. 35 Torques for customer pipeline

2. Support the weight of the piping so that its weight does not fall on connecting components.

6.6 Safety devices installed by the user

- The user must install the necessary safety devices.
 - Three PTC thermistor sensors should be installed by the user to protect against drive motor overheating or overloading.
 - A motor overload protection switch/overload relay (if not included with the deliverables) must be installed to monitor maximum current draw(s).
 - EMERGENCY OFF command device for immediate shut-down of the machine.
- The user must monitor the following parameters:
 - Permissible final pressure
 - Maximum block discharge temperature
- Consult KAESER for advice on this subject.



Safety valves and check valves are not regulating means in case of overpressure. The activation of the safety relief valve (blow-off valve) constitutes an impermissible operating state requiring immediate remedial measures.

6.7 Options

All options (except BB 52 C pr: (Option H2)) are mechanically installed/mounted. The electrical connections and evaluations are the customer's responsibility.

- Instructions on individual options should be followed.

6.7.1 Option C9 Connecting the pressure switch

- Connecting the pressure switch

Further information See chapter 13.5.1.

6.7.2 Option C10

Connecting the speed monitor

The sensor and transmitter are mechanically installed.

- A speed monitor sensor is supplied separately when ordered individually. Install in the user's control cabinet and wire up.

Further information See chapter 2.13.2 for the sensor settings.
The wiring diagram for the speed monitor is found in chapter 13.5.2.

6.7.3 Option C13

Connecting the temperature gauge switch

- Connect the temperature gauge switch.

Further information See electrical diagram in chapter 13.5.3.

6.7.4 Option C14

Connecting the pressure sensor

- Connecting the pressure sensor

Further information See chapter 13.5.4.

6.7.5 Option C19

Connecting the thermostat

- Connect the thermostat.

Further information See electrical diagram in chapter 13.5.5.

6.7.6 Option F5

Connecting the filter pressure differential switch

- Connect the filter pressure differential switch.

Further information See electrical diagram in chapter 13.5.6.

6.7.7 Option H2

Connecting the auxiliary heater

- The auxiliary heater is delivered uninstalled. The radiator, thermostat, and terminal box are already installed on a mounting plate.
- Connect the auxiliary heater in the terminal box.

Further information See the electrical diagram in chapter 13.5.7.

6.7.8 Option H11

Connecting the inlet pipe

If suction is to be from a pipeline, the inlet silencer is connected using a compensator.

Material Torque wrench

Precondition The compressed air system is vented completely to atmospheric pressure.

1. Connect to the compressed air network using the following torques:

Connection to an customer's pipeline	Torque [lbf-ft]	Torque [lbf-ft]
	BB 52 C pr	BB 69 C pr, BB 89 C pr
Compressor with hose clamps	7.4	14.8
Compressor with screwed joint M20*	—	—

* Manually tighten screws equally, pretension crosswise at 37 lbf-ft and subsequently retighten crosswise with torque according to table.

Tab. 36 Inlet compressor torques

2. Separately secure the inlet pipelines upstream of the compensator.

Further information Dimensional drawings for the pipeline connection is given in chapter 13.2 .

6.7.9 Option H12 Sound enclosure

6.7.9.1 Electrical connections

Subsequent work enables the access to the electrical connections of drive motor, fan and accessories.

1. Remove the access panel of the sound enclosure.
BB 52 C pr: Open the snap fasteners.
BB 69 C pr, BB 89 C pr: Latches are released by a key supplied with the machine.
2. Make the electrical connections.
3. Insert the access panel, and close the snap fasteners or latches.

6.7.9.2 Connecting the fan



BB 52 C pr: The sound enclosure is fitted with a fan only if the drive motor has a rated power of <5 hp and the machine is operated with frequency converter (Option C32).

The fan motor has a terminal box for direct supply connection.

The drive motor and the fan must run simultaneously.

Ensure correct direction of rotation when connecting the fan. The fan must blow air out of the sound enclosure.

The fan should run on for approximately 15 minutes after machine shut down to avoid temperature peaks inside the sound enclosure.

Precondition The power supply disconnecting device is switched off, the device is locked off, the absence of any voltage has been verified.

1. Select sufficient cable length.

2. Connect cables to the terminal box without mechanical stress.
3. Connect the protective ground.

Further information See electrical diagram in chapter 13.5.8.

6.8 Option H12

BB 69 C pr, BB 89 C pr with sound enclosure: Removing transport securing devices

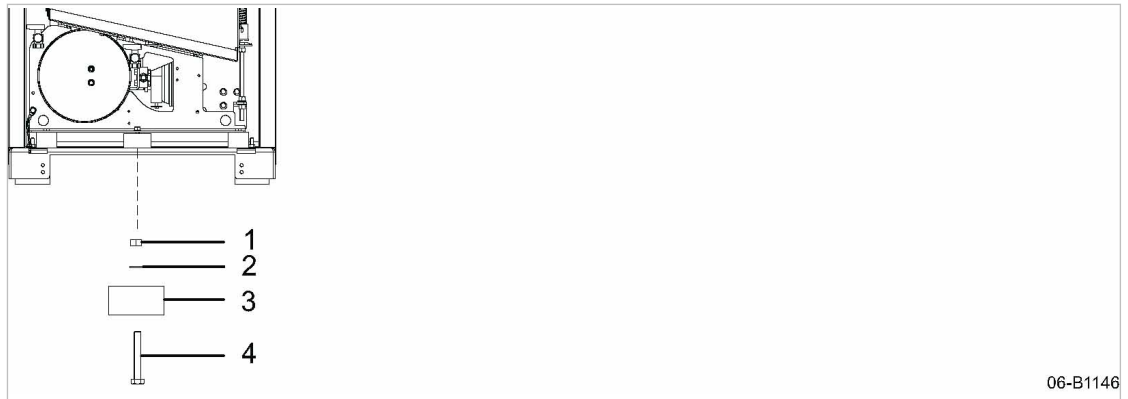

Fig. 28 Removing the transport securing devices

- | | |
|---------------|----------|
| ① Hexagon nut | ③ Spacer |
| ② Washer | ④ Screw |

Remove the transport securing devices after the machine has been installed.

1. Remove the access panel of the sound enclosure.
2. Remove the transport securing device and store for future transport if the machine.

7 Initial Start-up

7.1 Ensuring safety

This chapter provides instructions for safe commissioning of the machine. Warning instructions are provided prior to any potentially dangerous task.



Disregard of warning instructions can result in life-threatening injuries!

Observe safety instructions

Ignoring safety instructions can result in unforeseen dangers.

- Follow the instructions in chapter 3 “Safety and Responsibility”.
- Commissioning tasks may only be carried out by authorized installation personnel!
- Ensure that no personnel are working on the machine.
- Ensure that all cover panels are closed.

Working on live components

Touching live components can result in electric shocks, burns or death.

- Work on electrical equipment may only be carried out by authorized and certified electricians.
- Switch off the power supply disconnecting device, lock out / tag out the device, verify the absence of all voltage.
- Check that any floating contacts are free from voltage.

Working on the pressure system

Compressed air is stored energy. Uncontrolled release of this energy can cause serious injury or death. The following safety instructions relate to any work on components that might be pressurised.

- Switch off the power supply disconnecting device, lock out / tag out the device, verify the absence of all voltage.
- Close shut-off valves or otherwise isolate the machine from the compressed air network so as to ensure that no compressed air can flow back into the machine.
- Fully vent all pressurized components and enclosures.
- Do not open or dismantle any valves.

Working on the drive system

Touching live components can result in electric shocks, burns or death.

Touching the fan wheel or the belt drive while the machine is running can result in serious injury.

- Switch off the power supply disconnecting device, lock out / tag out against being switched on again, verify the absence of all voltage.

- Do not open any of the cover panels while the machine is switched on.
- If full protection is only provided when the machine is completely installed, then in all other phases of the machine's life-cycle temporary protective devices (e.g. covers) must be fitted, in order to guarantee that parts of the body cannot reach or be caught/sucked in by the rotary lobes.

Further information Information regarding authorized personnel can be found in chapter 3.4.2.
 Information regarding dangers and the avoidance thereof can be found in chapter 3.5.

7.2 Instructions to be observed before commissioning

Incorrect or improper commissioning can cause injury to persons and damage to the machine.

- Commissioning may be carried out only by authorized installation and service personnel who have been trained on this machine.

Special measures for recommissioning after storage/standstill

Storage period/ standstill longer than	Measure
12 months	<ul style="list-style-type: none"> ➤ Change the lubricating oil. ➤ Check the condition and tension of the drive belts. ➤ Have the frequency converter smoothing capacitors formed (refreshed) by an authorized KAESER service representative.
36 months	<ul style="list-style-type: none"> ➤ Have the overall technical condition checked by an authorized KAESER service representative.

Tab. 37 Recommissioning after storage/standstill

7.3 Checking installation and operating conditions

- Check and confirm all the items in the checklist before initially starting the machine.

To be checked	See chapter	Confirmed?
➤ Have all packing materials, tool and transport securing means been removed from the machine?	–	
➤ Are the operators completely familiar with safety regulations?	–	
➤ Have all the positioning conditions been complied with?	5	
➤ Has the automatic machine shut-down by the user's safety devices in the event of a fault been realized?	6.6	
➤ Are the power supply cable conductor cross-sections and fuse ratings adequate?	–	
➤ Are the tolerance limits of the power supply within the permissible tolerance limits of the nominal machine voltage?	–	
➤ Has the drive motor connection been checked?	6.4	

7 Initial Start-up

7.4 Checking the direction of rotation for the drive motor

To be checked	See chapter	Confirmed?
➤ Has the fan connection (sound enclosure) been checked? (Option H12)	6.7.9.2	
➤ Has the direction of rotation of drive motor and fan (sound enclosure) been checked?	7.4	
➤ All electrical connections checked for tightness? (The check must be repeated after 50 operating hours)	–	
➤ Is there adequate lubricating oil in the drive-end and gear-end of the block? (Level in the center of the sight glass)	10.5	
➤ Suitable non-return valve installed professionally?	6.5	
➤ Has the connection to the compressed air network been made with a hose or compensator?	6.5	
➤ Has the drive belt tension been checked? (The check must be repeated after 24 operating hours)	10.4	
➤ Is the machine anchored to the floor?	6.3	
➤ Are the access panel of the sound enclosure and other panels inserted and locked? (Option H12)	4.9.13	
➤ BB 52 C pr: Has the silicone seal protecting the outdoor-installed machine been checked for leaks? (Option H3, H12)	–	

Tab. 38 Installation conditions checklist

7.4 Checking the direction of rotation for the drive motor

The machine is designed for a clockwise phase sequence.

If the direction of rotation is incorrect, the flow direction will be reversed and air drawn in from the compressed air line.

An arrow indicating the direction of rotation is located at the drive-end of the blower block and on the belt guard.

Material Phase sequence indicator

NOTICE

Incorrect direction of rotation!

This may result in damage to the machine from intake of foreign articles or excessive vacuum.

➤ *Ensure the correct direction of rotation.*

1. Remove the filter maintenance cover from the inlet silencer or inlet filter and/or remove the check valve on the inlet side.
2. Verify the direction of rotation using a phase sequence indicator on the machine supply lines.
3. If the direction of rotation is incorrect, exchange phases L1 and L2 of the supply lines.



If you do not have access to a phase sequence indicator:

- Arrange for the phase sequence to be checked by an authorized KAESER service representative

**7.4.1 Option H12
Fan (sound enclosure)**

BB 52 C pr: In the case of drive motors with a rated power of <math><5.5\text{ hp}</math>, a fan is only fitted inside the sound enclosure if the machine is equipped for operation via frequency converter (Option C32).

An arrow on the fan indicates its correct direction of rotation.

The fan must blow air out of the sound enclosure.

- **Single-phase fan:** If the direction of rotation is incorrect, switch the electrical connection in the terminal box for the fan. Instructions regarding “right” and “left” operation are provided on the terminal box cover.
- **Three-phase fan:** If the direction of rotation is incorrect, exchange phases L1 and L2 of the supply lines.

8 Operation

8.1 Switching the machine on and off

To a large extent, the procedure for switching the machine on and off depends on which operating mode is intended for the process and on the equipment provided for it. Such equipment is to be installed at the user-end and thus does not constitute part of the scope of supply for the machine (except in the case of options).



Information regarding the function of the user-end control cabinet should be taken from the documentation provided by the control cabinet manufacturer.

8.1.1 Switching on

- Ensure that the machine is in perfect technical condition before switching it on. If the machine is equipped with a sound enclosure, check that the fan is fully operational.
- Switch the machine on only when it is fully stopped.



Maximum frequency of motor starts per hour: 6 times.
Option C32, operation with frequency converter
Maximum frequency of motor starts per hour: unlimited.

Precondition A suitable unloaded start device is installed in case of back pressure.
No personnel are inside the machine.

1. **⚠ WARNING** *Serious injury can be caused by compressed air!*
 - *Ensure that no personnel are working on the machine.*
2. Switch the machine on via the user-end control cabinet or if Option C32, operation with frequency converter, is specified: switch the machine on at the frequency converter.
 - For installation outdoors (Option H3/H12): Remove snow and/or ice from the machine.
1. **⚠ CAUTION** *Risk of accident from falling snow and/or ice loads!*
 - *Remove any snow and/or ice from the machine before commissioning.*
2. Remove snow and/or ice with caution.

8.1.2 Switching off

- Switch the machine off via the user-end control cabinet or if Option C32, operation with frequency converter, is specified: switch the machine off at the frequency converter.

8.2 Switching off in an emergency

The machine is not equipped with an emergency stop device. Such a device must be provided by the user unless it is part of an ordered option.

- Ensure the machine can be stopped immediately in an emergency.

8.3 Option H12 Checking the ventilator fan function



BB 52 C pr: The sound enclosure is fitted with a fan only if the drive motor has a rated power of <5 hp and the machine is operated under frequency control (Option C32).

NOTICE

Overheating inside the sound enclosure!

A failure of the ventilator fan can result in a breakdown of the blower block or other components.

- *If the ventilator fan stops, immediately provide an alternative flow of cooling air through the sound enclosure.*

- Check that air is actually being blown out of the enclosure cooling air outlet, e.g. by holding a sheet of paper in front of the outlet.

Further information An authorized KAESER service representative will advise on suitable measures.

9 Fault Recognition and Rectification

9.1 Basic instructions

The following tables are intended to assist in locating faults.

1. Do not attempt fault rectification measures other than those given in this manual!
2. In all other cases:
Have the fault rectified by an authorized KAESER service representative.

9.2 Faults

Fault	Possible cause	Remedy
Unusual noise when running.	Too much backlash in the timing gears.	Call an authorized KAESER service representative.
	Too much play in the rotor bearings.	Call an authorized KAESER service representative.
	Rotors not synchronized.	Keep the pressure differential and speed as specified. Call an authorized KAESER service representative.
Blower block runs too hot.	Pressure differential too great.	Check and correct pressure differential.
	Clogged inlet filter reducing air intake volume.	Clean the inlet filter.
	Rotor clearance too large.	Call an authorized KAESER service representative.
	Leakage due to incorrect installation of pressure-bearing components.	Call an authorized KAESER service representative.
Oil leaks from the gas drain.	Oil level too high.	Drain off oil until the correct level is reached.
Oil leaking from around the drive shaft.	Shaft seal defective.	Call an authorized KAESER service representative.
Reduced air inlet flow.	Rotor clearance too large because of wear.	Call an authorized KAESER service representative.
	Intake resistance too high.	Clean the inlet filter.

Fault	Possible cause	Remedy
Black film on the oil sight glasses.	Oil not changed at the correct interval.	Change the lubricating oil. Clean or replace the sight glass.
	Insufficient oil.	Change the lubricating oil. Clean or replace the sight glass.
	Oil overheated.	Call an authorized KAESER service representative.
	Block overloaded.	Call an authorized KAESER service representative.
Water in the oil.	Condensate build-up by prolonged storage and high humidity.	Change the lubricating oil.
Safety relief valve activates.	Inappropriate operating state, operating pressure too high.	Bring the machine to a permissible operational state or shut down.
PTC relay trips out.	Operating pressure too high.	Check and correct pressure differential.

Tab. 39 Faults and remedies

9.3 Options

This section provides remedies for technical faults concerning the machine's optional equipment.

9.3.1 Option H12 Sound enclosure faults

Alarm	Possible cause	Remedy
Overheating inside the sound enclosure!	Fan defective or turning in the wrong direction.	Check connection. Contact an authorized KAESER service representative.
	Flow of cooling air blocked.	Check and clean cooling air apertures. Check the cooling air inlet temperature.
	Drive motor overloaded.	Check operating conditions.
	Leakage due to incorrect installation of pressure-bearing components.	Contact an authorized KAESER service representative.

Tab. 40 Faults and remedies (option H12)

9.3.2 Option C14
Faulty pressure sensor

Fault	Possible cause	Remedy
No output signal.	No power supply, broken wire.	Check power supply and wires.
	Pressure transducer incorrectly connected.	Check power supply and wires.
	No input pressure.	Check pressure feed.
	Electronic defect from power supply voltage surge or external voltage.	Call an authorized KAESER service representative.
Output signal does not respond to pressure changes.	Input channel blocked.	Clean the input channel and throttle screw, being careful not to damage the delicate diaphragm.
	Electronic defect from power supply voltage surge or external voltage.	Call an authorized KAESER service representative.
	Pressure transducer defective from mechanical overloading.	Call an authorized KAESER service representative.
Output signal too high and not responding to pressure changes.	Electronic defect from power supply voltage surge or external voltage.	Call an authorized KAESER service representative.

Tab. 41 Faults and remedies (Option C14)

10 Maintenance

10.1 Ensuring safety

Follow the safety instructions below to ensure safe maintenance of the machine. Warning instructions are provided prior to any potentially dangerous task.



Disregard of warning instructions can result in life-threatening injuries!

Observe safety instructions

Ignoring safety instructions can result in unforeseen dangers.

- Follow the instructions in chapter 3 “Safety and Responsibility”.
- Maintenance work must be performed by authorized personnel only.
- Ensure that no personnel are working on the machine.
- Ensure that all cover panels are closed.

Working on live components

Touching live components can result in electric shocks, burns or death.

- Work on electrical equipment may only be carried out by authorized and certified electricians.
- Switch off the power supply disconnecting device, lock out / tag out the device, verify the absence of all voltage.
- Check that any floating contacts are free from voltage.

Working on the pressure system

Compressed air is stored energy. Uncontrolled release of this energy can cause serious injury or death. The following safety instructions relate to any work on components that might be pressurized.

- Switch off the power supply disconnecting device, lock out / tag out the device, verify the absence of all voltage.
- Close shut-off valves or otherwise isolate the machine from the compressed air network so as to ensure that no compressed air can flow back into the machine.
- Fully vent all pressurized components and enclosures.
- Do not open or dismantle any valves.

Working on the drive system

Touching live components can result in electric shocks, burns or death.

Touching the fan wheel or the belt drive while the machine is running can result in serious injury.

- Switch off the power supply disconnecting device, lock out / tag out the device, verify the absence of all voltage.

- Do not open any of the cover panels while the machine is switched on.
- If full protection is only provided when the machine is completely installed, then in all other phases of the machine's life-cycle temporary protective devices (e.g. covers) must be fitted, in order to guarantee that parts of the body cannot reach or be caught/sucked in by the rotary lobes.

Further information Information regarding authorized personnel can be found in chapter 3.4.2.
Information regarding dangers and the avoidance thereof can be found in chapter 3.5.

10.2 Maintenance schedule

10.2.1 Logging maintenance work



- The maintenance intervals given are those recommended for average operating conditions.
- Maintenance tasks should be carried out more frequently where operating conditions are unfavorable (e.g. dusty ambient) or when the equipment is in constant use.
 - Adjust the maintenance intervals with regard to local installation and operating conditions.
- Keep a log of all maintenance and service work.
This enables the frequency of individual maintenance tasks and deviations from our recommendations to be determined.

Further information A prepared log is provided in chapter 10.12.

10.2.2 Regular maintenance tasks

The table below lists the required maintenance tasks.



- If operating conditions are unfavorable (e.g. dusty ambient) or if the equipment is in constant use, maintenance tasks must be carried out more frequently (shorter intervals).
- Carry out maintenance tasks in a timely manner, taking the ambient and operating conditions into consideration:

Interval	Maintenance task	See chapter
At least 24 hours after initial commissioning	Check drive belt tension.	10.4
At least 50 hours after initial commissioning	Check that all electrical connections are secure and properly attach if necessary.	–
500 hours after initial commissioning*	Change the lubricating oil.	10.7
Up to 500 h or monthly	Check the oil level.	10.5
	Check drive belt tension.	10.4
	Check the air filter.	10.8
Up to 1000 h	Clean the machine.	10.9

h = operating hours

* Not applicable in the case of initial commissioning by an authorized KAESER service representative.

Interval	Maintenance task	See chapter
Up to 3000 h, At least once a year	Change the air filter.	10.8
Up to 3000 h At least once a year	Change the FGB 220 lubricating oil.	10.7
Annually	Check the safety relief valve.	10.11
	Check that all electrical connections are secure and attach if necessary.	–
Up to 3000 h, At least every 2 years	Change the SB 220 lubricating oil.	10.7
After 2 years	BB 52 C pr: Check the silicone joint seals at the sound enclosure of outdoor-installed machines for leaks and touch up, if necessary. (Option H3, H12).	–
Up to 12000 h, At least every 4 years	Replace the drive belt.	10.4

h = operating hours

* Not applicable in the case of initial commissioning by an authorized KAESER service representative.

Tab. 42 Regular maintenance tasks

10.2.3 Regular service tasks

The table below lists necessary maintenance tasks.

- Have an authorized KAESER SERVICE technician carry out maintenance tasks.
- Have maintenance tasks carried out in a timely manner, taking the ambient and operating conditions into account:

Interval	Service task
Up to 12000 h	(Option C11) Unloaded start valve with solenoid valve: Maintain the solenoid valve
Up to 12000 h, At least every 4 years	Permanently greased drive motor bearings: Replace the motor bearings.
Up to 36000 h	Blower block: Replace the radial shaft sealing ring.
	(Option H12) Sound enclosure fan: Replace the fan.
	(Option C11) Maintain the unloaded start valve.
	(Option C18) Maintain the unloaded start valve with regulating valve.
Up to 36000 h, At least every 8 years	(Option G1) Maintain the check valve.
	Replace the compensators.

h = operating hours

Tab. 43 Regular maintenance tasks

10.3 Option H12 Sound enclosure

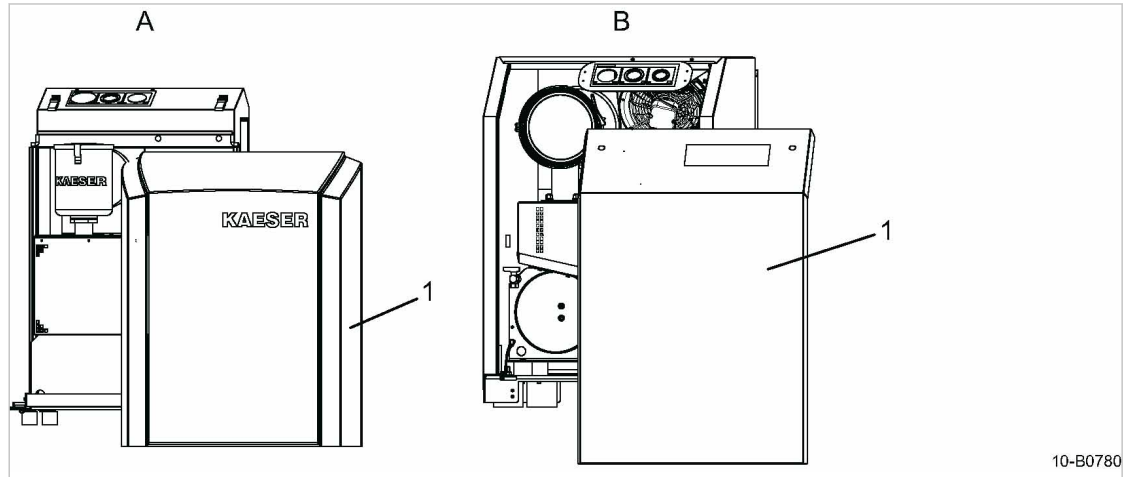

Fig. 29 Sound enclosure

- (A) BB 52 C pr
- (B) BB 69 C pr, BB 89 C pr
- (1) Removable panel

- Remove the panel (1) for maintenance work.
BB 52 C pr: Open the snap fasteners.
BB 69 C pr, BB 89 C pr: Use the supplied key to release the latches.

10.4 Drive belt maintenance

Material Spare parts (if required)

Precondition The power supply disconnecting device is switched off,
lock out and tag out the device,
the absence of any voltage has been verified.
The machine has cooled down.

⚠ WARNING

Touching the moving drive belt may result in severe bruising or even loss of limb or extremities.

- *Switch off and lock out/tag out the power supply disconnecting device and verify the absence of voltage.*

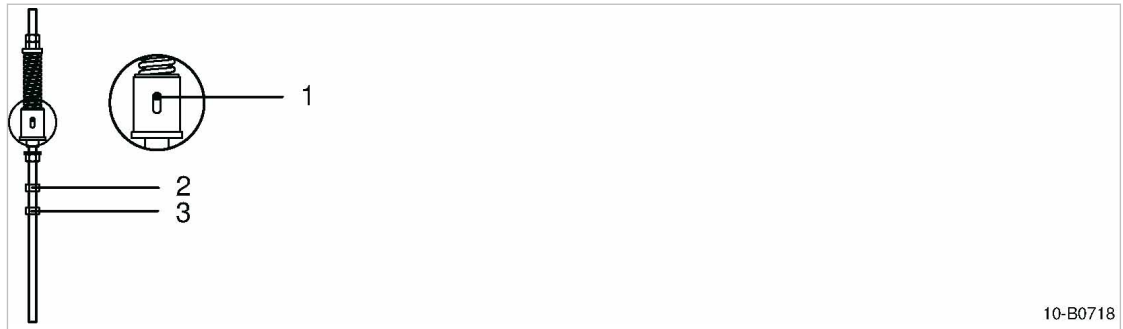

Fig. 30 Drive belt maintenance

- ① Marker pin (shown as: belt tensioning required)
- ② Locking nut
- ③ Adjusting nut

Checking belt tension and adjustment

The tensioning device uses spring force to apply correct tension to the belt.

Adjust the tension before the marker pin reaches the **top** end of the elongated hole.

1. Loosen the locking nut ②.
2. Use the adjusting nut ③ to adjust spring tension until the marker pin reaches the lower end of the elongated hole.
3. Tighten the locking nut ②.

Visually check for damages.

1. **⚠ CAUTION** *Danger of pinching between belt and pulley!*
 - *Work carefully.*
2. Turn the pulley by hand so that the entire belt can be inspected for damage.
3. In case of damage: Replace the drive belt immediately.



When individual belts fail in multiple-groove drives, all belts must be replaced.

Changing the belt.

1. Remove the belt guard.
2. Loosen the locking nut ②.
3. Turn the adjusting nut ③ to loosen the tension on the belts until they can be removed from the pulley.
4. Install the new set of belts and use the adjusting nut ③ to adjust the tension until the marker pin reaches the lower end of the elongated hole.
5. Tighten the locking nut ②.
6. Replace the belt guard.
7. Check the tension after the new belt has been in operation for 50 hours.

10.5 Checking the oil level

The true oil level can be seen in the oil sight glass only when the machine is stopped.



The gear-end and drive-end oil chambers are not connected.

⚠ WARNING

Danger of burns from hot components!

- *Wear long-sleeved clothing and protective gloves.*

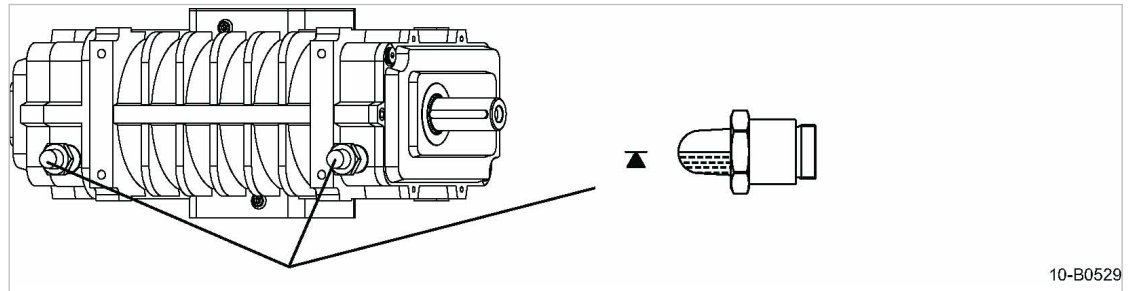

Fig. 31 Checking the oil level

1. Check the oil level in the sight glasses on both ends of the block.
2. Replenish as soon as the level falls 0.2 in. below the center of the sight glass.

10.6 Replenishing lubricating oil

Labels giving the oil type for topping off are to be found on the blower block and belt guard.



The machine must be isolated from the compressed air network and completely vented before undertaking any work on the pressure system.

Precondition The power supply disconnecting device is switched off, the disconnecting device is locked in the off position, the oil level has settled.

⚠ WARNING

Danger of burns from hot components and oil!

- *Wear long-sleeved clothing and protective gloves.*

NOTICE

Unsuitable oil can damage the block!

- *Never mix different types of oil.*
- *Never top off with a different type of oil to that already used in the block.*

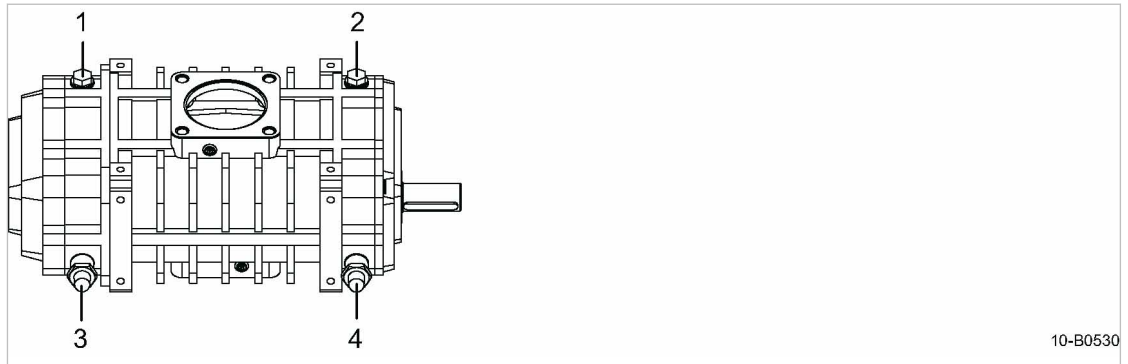

Fig. 32 Replenishing lubricating oil

- | | |
|--|--|
| <p>① Plug
(gear-end oil filling port)</p> <p>② Plug
(drive-end oil filling port)</p> | <p>③ Gear-end oil sight glass</p> <p>④ Drive-end oil sight glass</p> |
|--|--|

1. Slowly remove the plug ① and/or ②.
2. Top off until the level is at the marking on the sight glass ③ and/or ④.
3. Screw in the plugs.
4. Visually check for leaks.

10.7 Changing the oil



Prior to any work requiring the opening of the pressure system, the machine must be fully isolated from the compressed air network and completely depressurized.

The oil should be changed with the block temperature at 130 F to ensure the oil flows freely.

Drain all of the oil thoroughly from the blower block:

- Gear-end
- Drive-end

Material Lubricating oil
Oil receptacle

Precondition The power supply disconnecting device is switched off, the device is locked out / tagged out, the absence of voltage has been verified.

⚠ WARNING

Danger of burns from hot components and oil!

- *Wear long-sleeved clothing and protective gloves.*

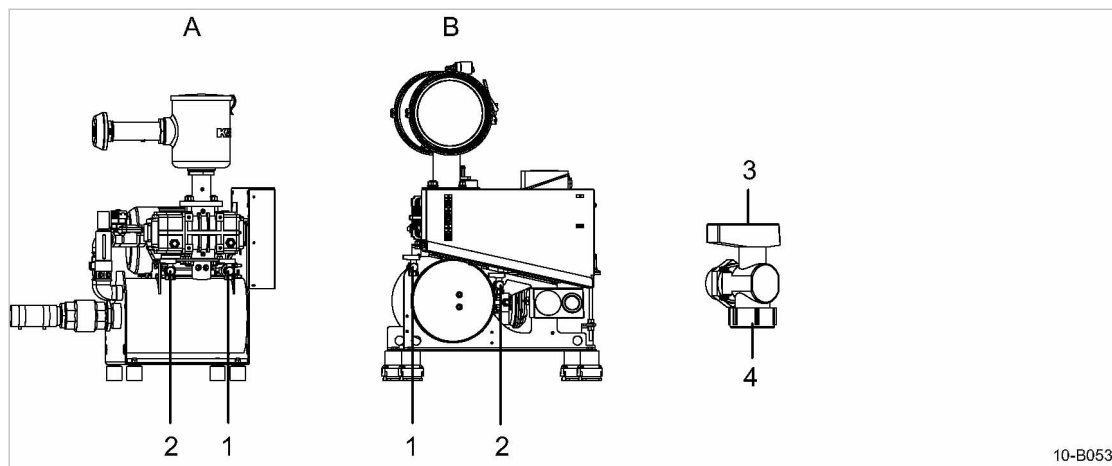

Fig. 33 Oil drain tap with handle

- | | | | |
|-----|------------------------|-----|---------------|
| (A) | BB 52 C pr | (2) | Gear-end |
| (B) | BB 69 C pr, BB 89 C pr | (3) | Oil drain tap |
| (1) | Drive-end | (4) | Cap |

Draining the oil

1. Prepare an oil receptacle.
2. Slowly unscrew screw plugs on the oil inlets on the blower block, positions (1) and (2) from figure 32.
3. Screw off caps (4), secure against reclosing and ensure that the oil can flow freely.
4. Open oil drain taps (3) and let oil drain out.



Dispose of the old lubricating oil in accordance with local environmental protection regulations.

Filling with fresh oil

1. Fill with fresh oil.
2. Allow the oil drain taps to remain open until oil begins to run out (bleeding the oil drain lines).
3. Close oil drain taps (3).
4. Check the oil level using the oil sight glasses on the gear and drive-end (see figure 32) and fill if necessary.
5. Screw on caps (4).
6. Screw in screw plugs of the oil inlets on the blower block.
7. Visually check for leaks.

10.8 Air filter maintenance

The air filter protects the supplied pressure system from dirt entering.

NOTICE

Machine damage caused by unsuitable air filter!

The use of an unsuitable air filter can permit dirt to enter the pressure system and cause damage to the machine.

➤ Use a suitable air filter.



The air filter cannot be cleaned.

10.8.1 Filter maintenance indicator

The maintenance indicator shows when the filter needs maintenance. When the filter becomes clogged and flow resistance rises to a set point, the maintenance signal is given.

Machine without sound enclosure

The filter maintenance indicator is installed at the intake silencer.

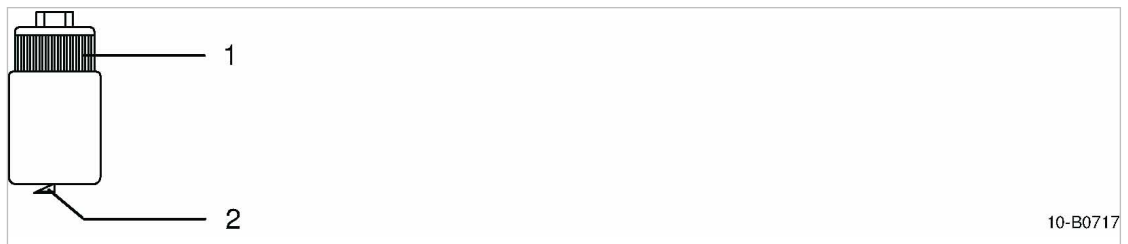

Fig. 34 Filter maintenance indicator (machine without sound enclosure)

- ① Signal ring
- ② Reset button

1. Change the air filter when the signal ring ① shows red.
2. Unlatch the signal ring by pressing the reset button ②.

Option H12 Machine with sound enclosure

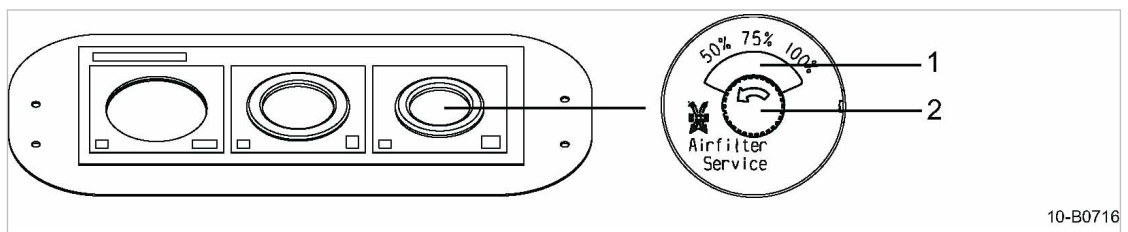

Fig. 35 Filter maintenance indicator (machine with sound enclosure)

- ① Indicator range
- ② Reset button

1. Replace the filter when the maintenance indicator reads more than 50%.
2. Reset to the indication range ① by pressing the reset button ②.

10.8.2 Option F5 Filter pressure differential switch

The filter pressure differential switch monitors contamination of the intake filter.

The switch is triggered by pressure differential. Falling below or rising above the set value causes the current flow to switch on, switch off or changeover according to how the switch is wired.

- Change the air filter if the pressure differential switch activates.

10.8.3 Changing the air filter



The machine must be isolated from the compressed air network and completely vented before undertaking any work on the pressure system.

Material Spare parts

Precondition The power supply disconnecting device is switched off, the device is locked off, the absence of voltage has been verified.

⚠ WARNING

Danger of burns from hot components!

- *Wear long-sleeved clothing and gloves.*

BB 52 C pr

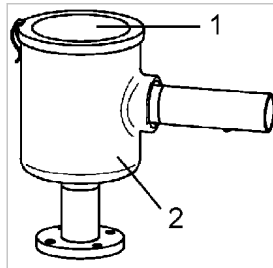

10-B1084

Fig. 36 Changing the air filter (BB 52 C pr)

- ① Cover
- ② Inlet silencer

1. Open the snap fastener on the inlet silencer cover ②.
2. Take off the cover ①.
3. Remove the clogged air filter.
4. Clean all parts and sealing surfaces.
5. Insert the new air filter.
6. Secure the silencer cover.

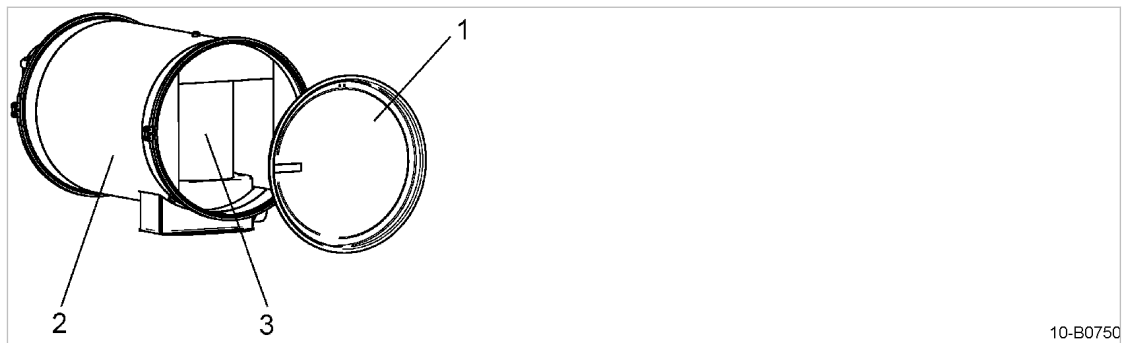
BB 69 C pr, BB 89 C pr

10-B0750

Fig. 37 Changing the air filter (BB 69 C pr, BB 89 C pr)

- ① Cover
- ② Inlet silencer
- ③ Air filter

1. Open the snap fastener on the inlet silencer cover ② .
2. Take off the cover ①.
3. Loosen the Velcro strip and remove the air filter ③.
4. Clean all parts and sealing surfaces.
5. Place the new filter in the inlet silencer and secure with the Velcro strip.
6. Secure the silencer cover.

10.9 Machine cleaning

Regularly clean the machine. This ensures reliable cooling of the machine. The frequency is mainly dependent on local operating conditions.



Clogged machines are indicative of unfavorable ambient conditions. Such ambient conditions clog the cooling air ducts in the machine's interior and the motors resulting in increased wear and tear.

Material Brush and/or compressed air
 Protective gloves
 Face mask and safety goggles (if required)
 Vacuum cleaner

Precondition The power supply disconnecting device is switched off,
 the device is locked off,
 the absence of any voltage has been verified.
 The machine has cooled down.

1. Open the sound enclosure (Option H12).
 Dismantle panels in order to clean the cooling air ducts of the drive motor.
2. Dry brush the machine or blow off with compressed air.
3. Vacuum off dirt.
4. Close sound enclosure (Option H12).
 Replace and lock panels.



The machine cannot be cleaned?

- Have severe clogging removed by an authorized KAESER service representative.

10.10 Motor maintenance

10.10.1 Permanently lubricated drive motor bearings

The motor bearings are permanently lubricated. No re-greasing is necessary.

- The motor bearings must be replaced in the course of regular maintenance by an authorized KAESER service representative.

10.10.2 Option H12 Fan motor (sound enclosure)



BB 52 C pr: In the case of drive motors with a rated power of <5 hp, a fan is only fitted inside the sound enclosure if the machine is equipped for operation via frequency converter (Option C32).

The motor bearings are permanently lubricated. No re-greasing is necessary.

- The fan must be replaced in the course of regular maintenance by an authorized KAESER service representative.

10.11 Testing the safety relief valve

BB 52 C pr

In the event that the permissible working pressure is exceeded, the safety relief valve will open. Free movement of the safety relief valve pull rod is checked by lifting it manually.

Precondition The machine is switched off.
The machine has been vented.

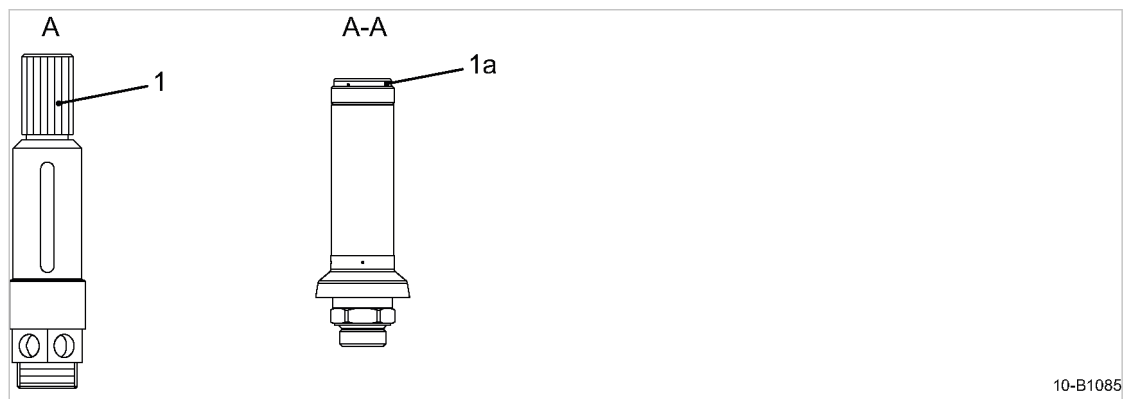

Fig. 38 Checking the safety relief valve (BB 52 C pr)

A Variant A, BB 52 C pr

AA Variant AA, BB 52 C pr

1 Cap

1a Lifting nut

- To lift, turn the cap **1** or lifting nut **1a** in an counterclockwise direction. After lifting, rotate back as far as the limit stop. Observe applicable local regulations.

- Never operate the machine without a properly functioning safety relief valve.
- Do **not** adjust the safety relief valve.
- Replace defective safety relief valves.

BB 69 C pr, BB 89 C pr

In the event that the permissible working pressure is exceeded, the safety relief valve will open. Free movement of the safety relief valve pull rod is checked either by lifting it manually or by using a lifting device.

Precondition The machine is switched off.
The machine has been vented.

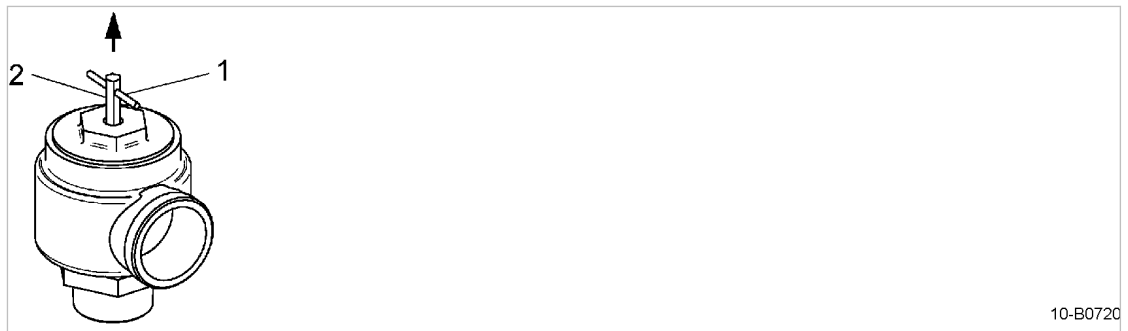

Fig. 39 Checking the safety relief valve (BB 69 C pr, BB 89 C pr)

- ① Lifting lever
- ② Pull rod

- Check for free movement of the pull rod (②) by pulling vertically on the lifting lever (①).
- Never operate the machine without a properly functioning safety relief valve.
- Do **not** adjust the safety relief valve.
- Replace defective safety relief valves.

11 Spares, Operating Materials, Service

11.1 Note the nameplate

The nameplate contains all information to identify your machine. This information is essential to us in order to provide you with optimal service.

- Please give the information from the nameplate with every inquiry and order for spares.

11.2 Ordering consumable parts and operating fluids/materials

KAESER consumable parts and operating fluids/materials have the same characteristics as the originals. They are specifically selected for use in KAESER machines.

⚠ WARNING

There is risk of personal injury or damage to the machine resulting from the use of unsuitable spare parts or operating fluids/materials.

Non-Kaeser parts and operating fluids/materials may be unsuitable or of poor quality and can damage the machine or impair its proper function.

Personal injury may result from damage.

- *Use only original KAESER parts and operating fluids/materials.*
- *Have an authorized KAESER SERVICE representative carry out regular repair and maintenance.*

Machine

Name	Number
Drive belt	1800
Air filter	1250
Lubricating oil	1600

Tab. 45 Consumable parts and operating fluids/materials

11.3 Spare parts for service and repair

Use this spare parts list to plan your material requirement according to operating conditions and to order the required spare parts.



- Make sure that any service or repair tasks not described in this manual are carried out by an authorized KAESER service representative.

11.3.1 BB 52 C pr, Machine without sound enclosure

(Option)

SEG-1867_01

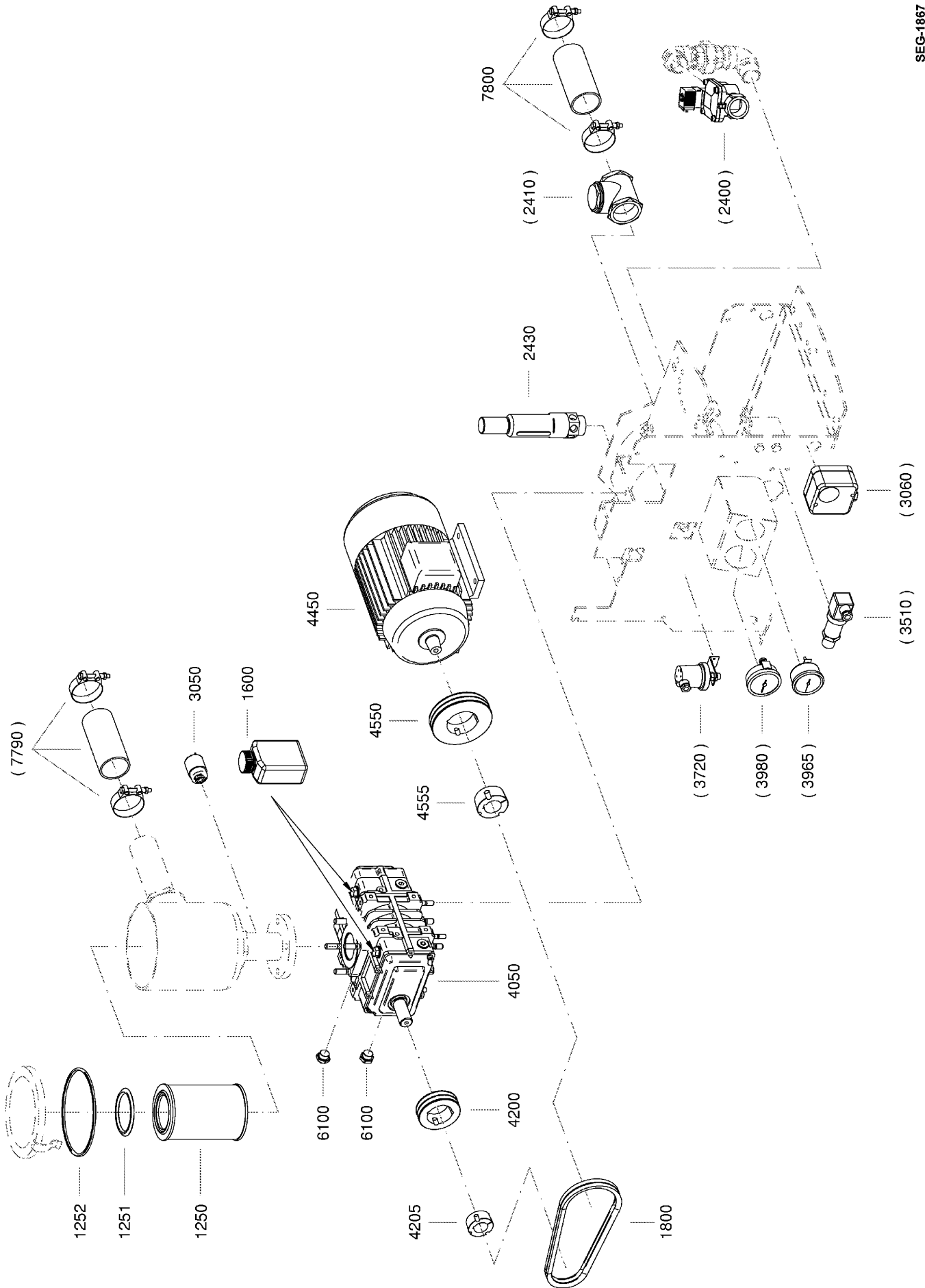

		Legende	KAESER
		BB 52 C	SEL-1715_01D
Pos.Nr.	Bezeichnung	Option	
1250	Luftfilter		
1251	Luftfilterdichtung		
1252	Deckeldichtung		
1600	OMEGA FLUID *)		
1800	Antriebsriemen		
2400	Anfahrregelventil		X
2402	Revisionsatz Anfahrregelventil		
2410	Rückschlagventil		X
2412	Revisionsatz Rückschlagventil		
2430	Überdruckbegrenzungsventil		
3050	Wartungsanzeige		
3060	Differenzdruckschalter		X
3510	Drucksensor		X
3720	Druckschalter		X
3965	Temperaturanzeige		X
3980	Druckanzeige		X
4050	Gebälseblock OMEGA		
4052	Wellendichtung		
4200	Riemenscheibe		
4205	Taperbuchse		
4450	Motor		
4451	Motorlagersatz		
4550	Riemenscheibe		
4555	Taperbuchse		
6100	Ölstandsanzeige		
7790	Schlauchleitung		X
7800	Schlauchleitung		

Bitte geben Sie bei der Ersatzteilbestellung Material- und Seriennummer der Anlage sowie Positionsnummer und Bezeichnung der Ersatzteile an.

Vor und bei Ausführung aller Arbeiten sind die Sicherheits- und Servicehinweise in der Betriebsanleitung der Maschine zu beachten!

Wartungsintervalle bei günstigen Umgebungs- und Betriebsbedingungen wie kühle bis mäßige Umgebungstemperatur, niedrige Luftfeuchtigkeit und saubere Ansaugluft.

Abhängig von den Umgebungs- und Betriebsbedingungen können sich die Wartungsintervalle verkürzen.

*) siehe Betriebsanleitung

11.3.2 Option H12**BB 52 C pr, Machine with sound enclosure**

(Option)

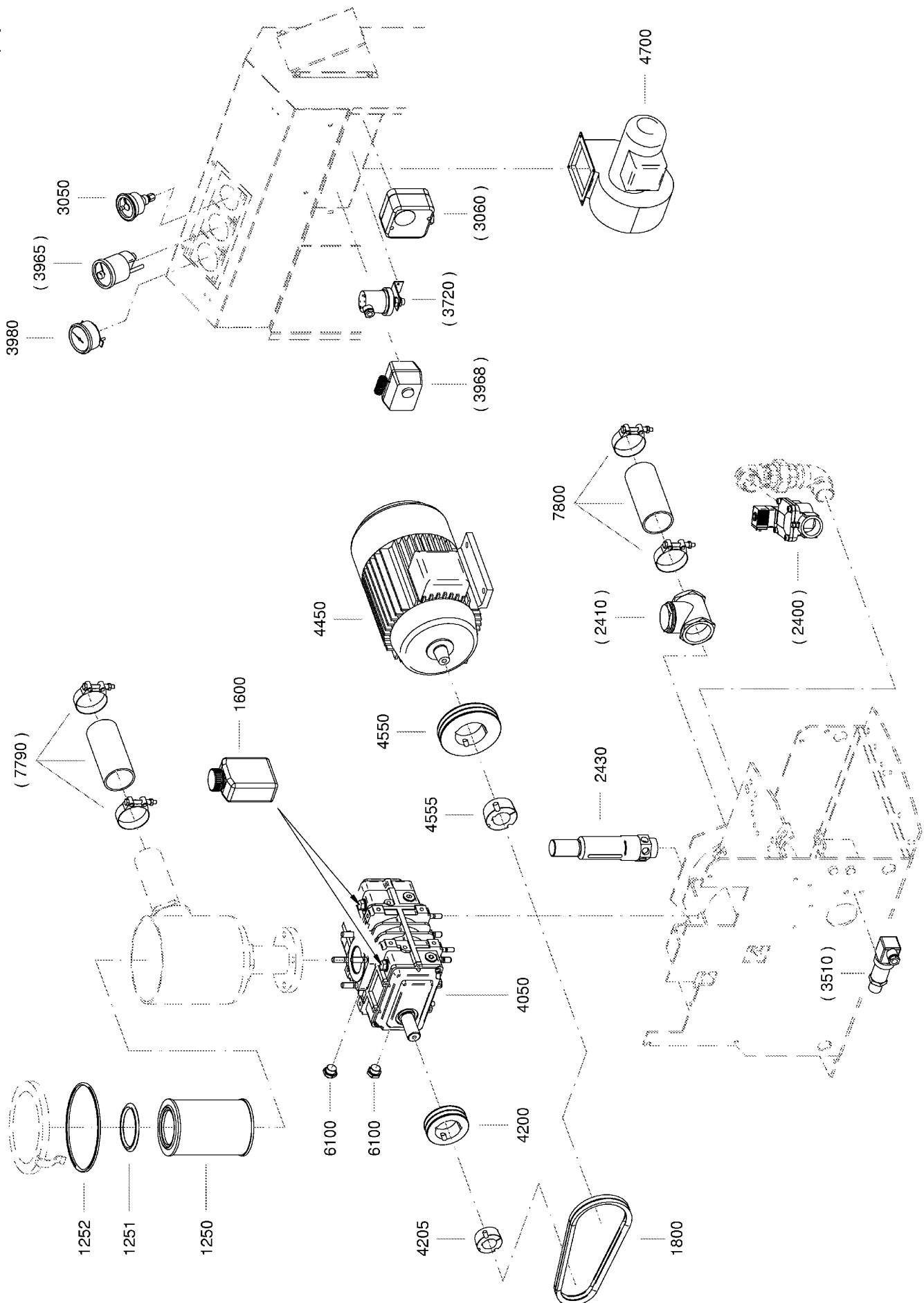

SEG-1706_02

		Legend	KAESER
		BB 52 C	SEL-1635_02E
Item	Name	Option	
1250	Air filter		
1251	Air filter seal		
1252	Cover seal		
1600	OMEGA FLUID *)		
1800	Drive belts		
2400	Start control valve		X
2402	Overhaul kit, start control valve		
2410	Check valve		X
2412	Check valve overhaul kit		
2430	Pressure limiting valve		
3050	Maintenance indicator		
3060	Pressure differential switch		X
3510	Pressure transducer		X
3720	Pressure switch		X
3965	Temperature gauge		X
3968	Thermostat		X
3980	Pressure gauge		
4050	OMEGA blower block		
4052	Shaft seal		
4200	Belt pulley		
4205	Tapered bushing		
4450	Motor		
4451	Motor bearing kit		
4550	Belt pulley		
4555	Tapered bushing		
4700	Fan		
6100	Oil level indicator		
7790	Prepared hose		X
7800	Prepared hose		

Please quote the part number and serial number of the machine together with the item number and the description of the part when ordering.

Before and during all work, be sure to read and follow the safety and service instructions in the machine's service manual.

Maintenance intervals under good ambient and operating conditions, such as low to moderate ambient temperature and dry, clean inlet air.

Maintenance intervals may decrease due to ambient and operating conditions.

*) See service manual

11.3.3 BB 69 C pr, BB 89 C pr

Service-Kit
(Option)

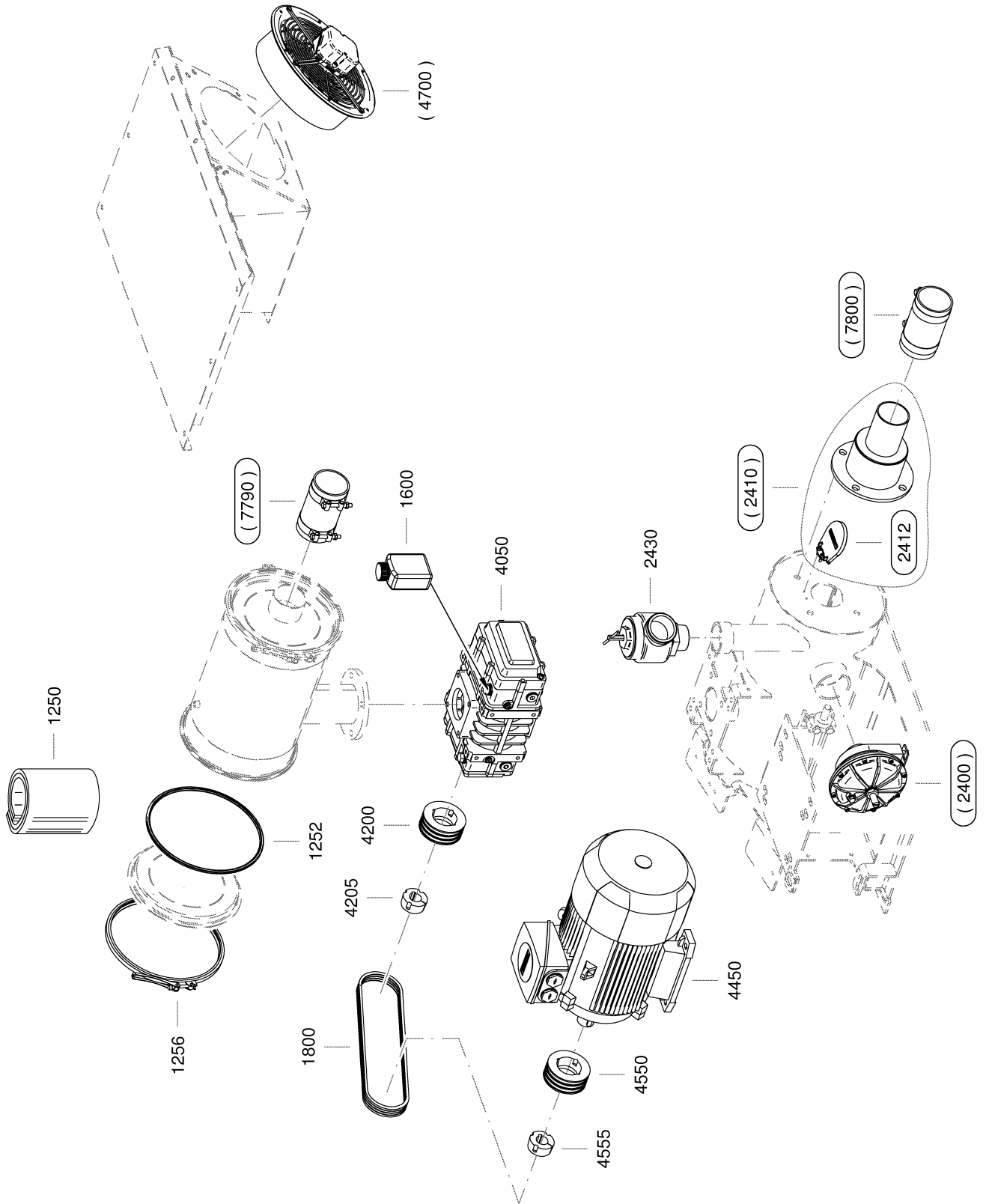

SEG-5470_01

Legend		KAESER
	BBC.2 pr	SEL-3900_01 E
Item	Description	Option
1250	Air filter insert	
1252	Inlet silencer gasket	
1256	Canopy fastener	
1600	OMEGA FLUID	
1800	Drive belt	
2400	Start control valve	X
2410	Check valve	X
2412	Overhaul kit, check valve	X
2430	Pressure limiting valve	
4050	OMEGA blower block	
4200	Airend pulley	
4205	Tapered bushing, airend	
4450	Drive motor	
4550	Drive motor pulley	
4555	Tapered bushing, drive motor	
4700	Fan unit	X
7790	Compensator, air inlet	X
7800	Compensator, air outlet	X

11.4 KAESER AIR SERVICE

KAESER AIR SERVICE offers:

- authorized KAESER service representatives with KAESER factory training,
- increased operational reliability ensured by preventive maintenance,
- energy savings achieved by avoidance of pressure losses,
- optimum conditions for operation of the compressed air system,
- the security of genuine KAESER spare parts,
- increased legal certainty as all regulations are kept to.

➤ Why not sign a KAESER AIR SERVICE maintenance agreement!

Result Your advantage:
lower costs and higher compressed air availability.

11.5 Completing the contamination declaration

Every company (user) is responsible for the health and safety of its employees. This extends to personnel who carry out servicing work at the user or service contractor.

A Declaration of Contamination must be completed and signed whenever maintenance or repair work is to be carried out on the machine.

1. Contact KAESER SERVICE and request the contamination declaration form.
2. Attach a copy of the Declaration of Contamination to the **outside** of the packing.

12 Decommissioning, Storage and Transport

12.1 Decommissioning

Decommissioning is required under circumstances such as the following:

- The machine is (temporarily) not required.
- The machine is to be transported to another location.
- The machine is to be scrapped.

Temporary decommissioning

Precondition The machine can be started at regular intervals.

- Run the machine once per week, or once per day under unfavorable weather conditions, for a minimum of 30 minutes at operating temperature in order to ensure adequate corrosion protection.

Long-term decommissioning



Long-term decommissioning leads to corrosion damage to the machine and should be avoided.

KAESER will be glad to assist you regarding any questions concerning correct storage and decommissioning.

Precondition The power supply disconnecting device is switched off, lock out / tag out the device, the absence of all voltage has been verified.
The machine is fully vented.

1. Allow the machine to cool down completely.
2. Disconnect all connecting lines and the power supply.
3. Release the tension from the drive belt.
4. Spray the machine inside and out with a preserving agent to protect from corrosion.
5. Store the machine in a dry, frost-proof room.

Further information For information on preservative oils, see chapter 12.4.

12.2 Packing

A wooden crate is required for overland transport to protect the machine from mechanical damage. Other measures must be taken for the transport of machines by sea or air. Please contact an authorized KAESER SERVICE for more information.

Material Protective plastic sheeting
Wooden transport crate

Precondition The machine is decommissioned.
The machine is dry and cooled down.

1. Wrap the machine fully in plastic sheeting.
2. Protect the machine in a wooden crate against mechanical damages.

12.3 Transport

12.3.1 Safety

Weight and center of gravity determine the most suitable method of transportation. Both are specified in the dimensional drawing in chapter 13.2.

Precondition Transport only by pallet truck, forklift truck, or lifting gear by personnel trained in the safe transportation of loads.

- Ensure the danger area is clear of personnel.

12.3.2 Transport machine with a pallet truck or forklift truck

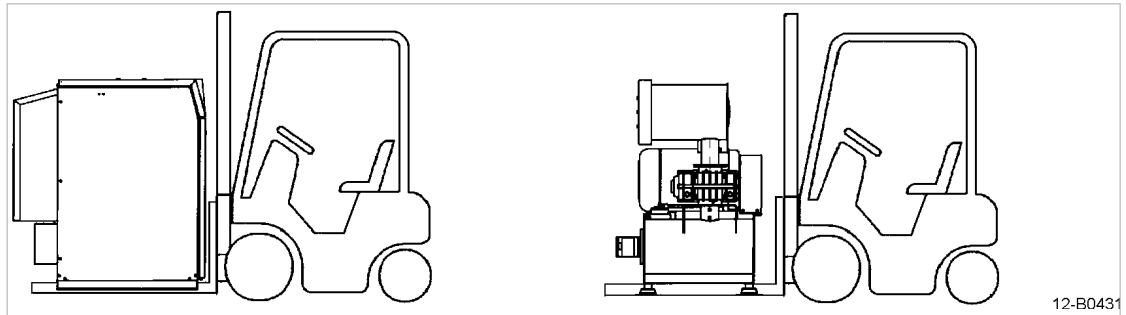

Fig. 40 Transport

1. Jack up machine if necessary.
2. Take note of the center of gravity.
3. Drive the pallet truck fully or forklift truck beneath the entire machine and transport with care.
4. Carry the wooden blocks with the machine to the new location.
5. Lower the machine onto the blocks.
6. Use the lever to lift the machine and remove the blocks.

Option H12 BB 69 C pr, BB 89 C pr with sound enclosure

1. Install the transport safety devices (see chapter 6.8).
2. Take note of the center of gravity.
3. Drive the pallet truck fully or forklift truck beneath the entire machine and transport with care.

12.4 Storage

Moisture can lead to corrosion, particularly on the surfaces of the blower block. The storage temperature must not fall below -22°F .



Should you have any questions concerning the correct storage and recommissioning procedure, KAESER will be glad to assist you.

⚠ CAUTION

Rotating lobes!

Risk of injury from crushing or severing of limbs.

- *Do not reach into the interior of the blower block.*
- *If full protection is only provided when the machine is completely installed, then in all other phases of the machine's life-cycle temporary protective devices (e.g. covers) must be fitted, in order to guarantee that parts of the body cannot reach or be caught/sucked in by the rotary lobes.*

NOTICE

Moisture and frost can damage the machine.

- *Prevent the ingress of moisture and formation of condensation.*
- Store the machine in a dry, frost-proof room.
- Seal off the inlet and discharge ports to prevent the ingress of dirt.

Following long-term storage

Longer downtimes lead to corrosion damage and should be avoided.

- Observe the procedures for assembly and initial commissioning.

12.5 Disposal

When disposing of a machine, drain out all liquids and remove old filters.

Precondition The machine is decommissioned.

1. Completely drain the oil from the machine.
2. Remove old filters.
3. Hand the machine over to an authorized disposal expert.



- Components contaminated with oil must be disposed of in accordance with local environmental protection regulations.

13 Annex

13.1 Pipeline and instrument flow diagram (P+I diagram)

13.2 Dimensional drawing

13.2.1 BB 52 C pr

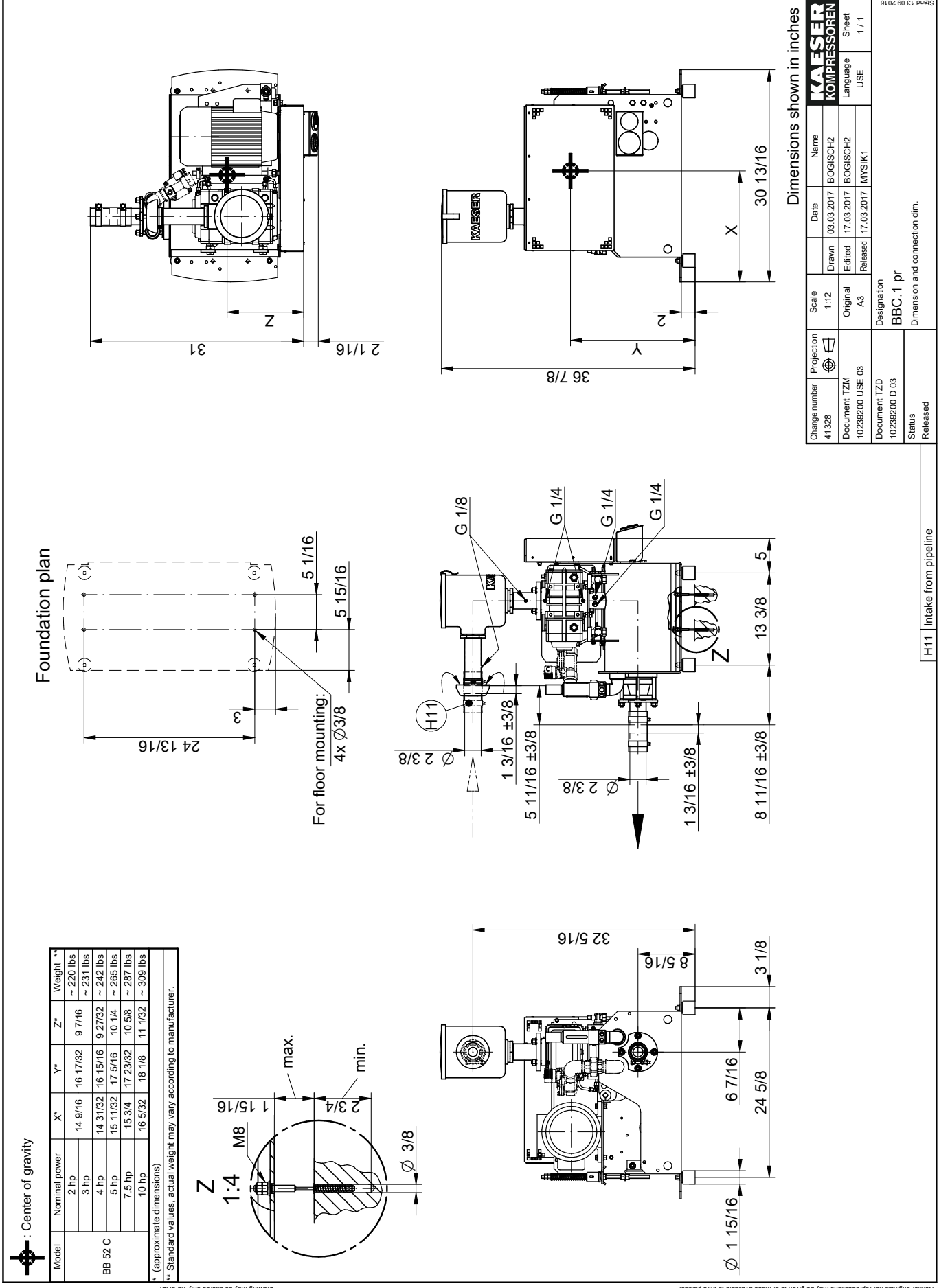

Model	Nominal power	X*	Y*	Z*	Weight**
BB 52 C	2 hp	14 9/16	16 17/32	9 7/16	~ 220 lbs
	3 hp	14 31/32	16 15/16	9 27/32	~ 231 lbs
	4 hp	15 11/32	17 5/16	10 1/4	~ 242 lbs
	5 hp	15 3/4	17 23/32	10 5/8	~ 265 lbs
	7.5 hp	16 5/32	18 1/8	11 1/32	~ 287 lbs
	10 hp				~ 309 lbs

* (approximate dimensions)
** Standard values, actual weight may vary according to manufacturer.

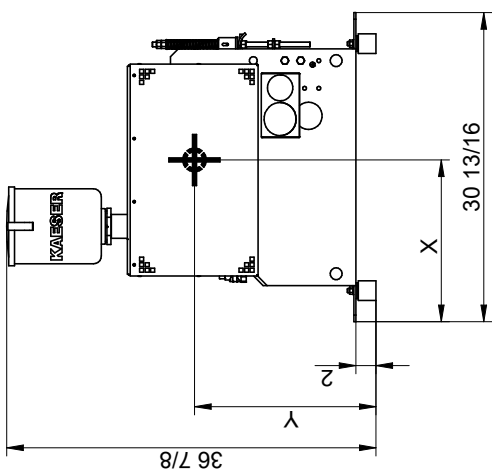
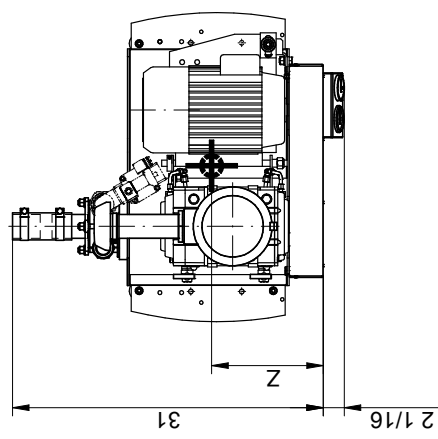
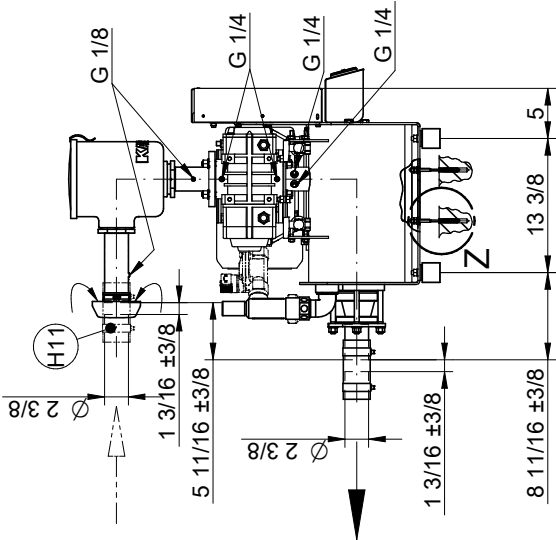
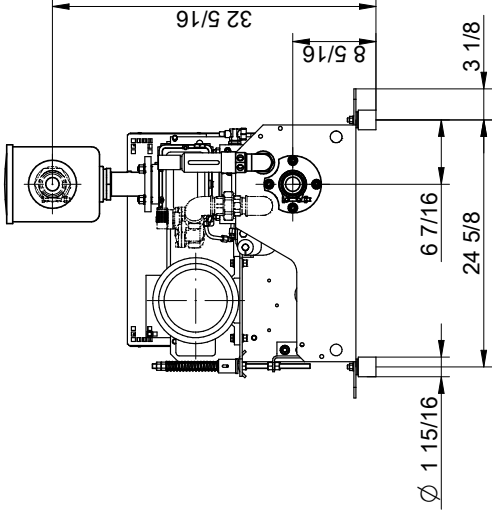
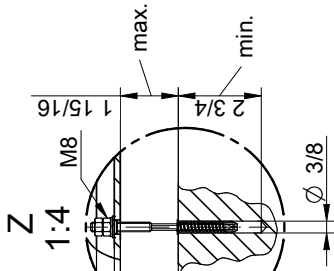



Model	Nominal power	X*	Y*	Z*	Weight**
BB 52 C	2 hp	13 25/32	19 11/16	11 13/16	~ 375 lbs
	3 hp	14 3/16	19 9/32	12 7/32	~ 386 lbs
	4 hp	14 31/32	19 9/32	12 7/32	~ 397 lbs
	5 hp	15 3/4	18 29/32	13 3/8	~ 419 lbs
	7.5 hp	16 17/32	18 1/2	14 3/16	~ 441 lbs
	10 hp	17 5/16	18 1/8	14 31/32	~ 463 lbs

(approximate dimensions)
** Standard values, actual weight may vary according to manufacturer.
Subject to development-related changes.
Drawing may be altered only via CAD.

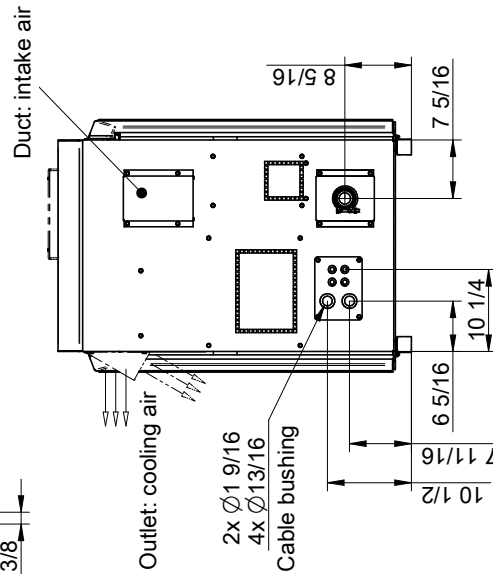
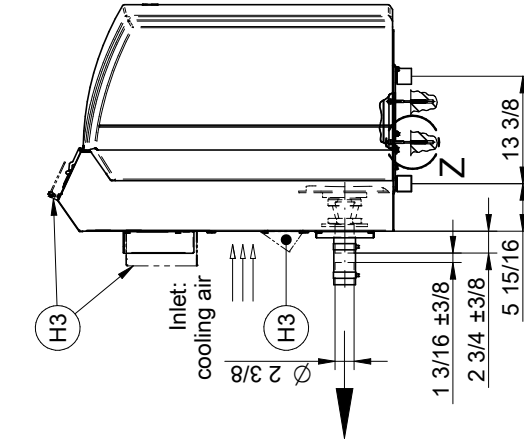
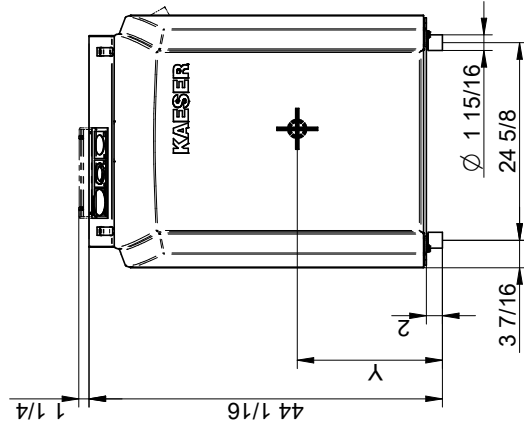
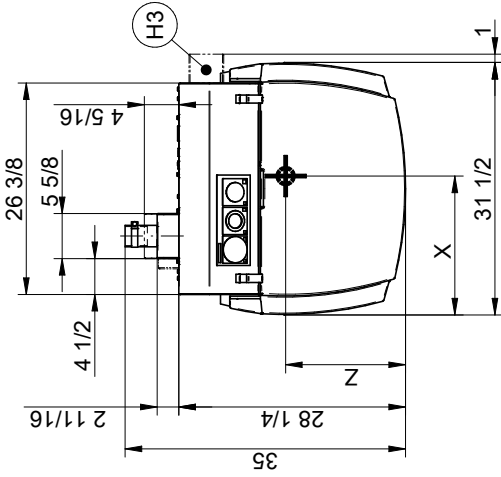
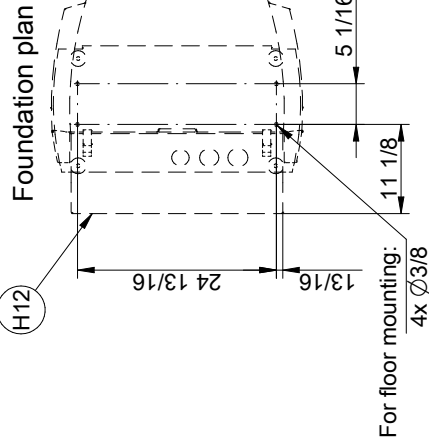
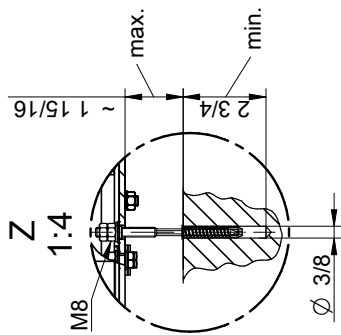

Dimensions shown in inches

Change number	Projection	Scale	Date	Name
41 328	1:15	Original	07.03.2017	BOGISCHE2
10238974 USE 02	A3	Edited	17.03.2017	BOGISCHE2
10238974 D 02	Released	Released	17.03.2017	MYSIK1

Document TZM	Language	Sheet
10238974 USE 02	USE	1 / 1

Document TZD	Designation
10238974 D 02	BBC.1 pr H12

Dimension and connection dim.

H12	with sound enclosure
H3	Outdoor installation

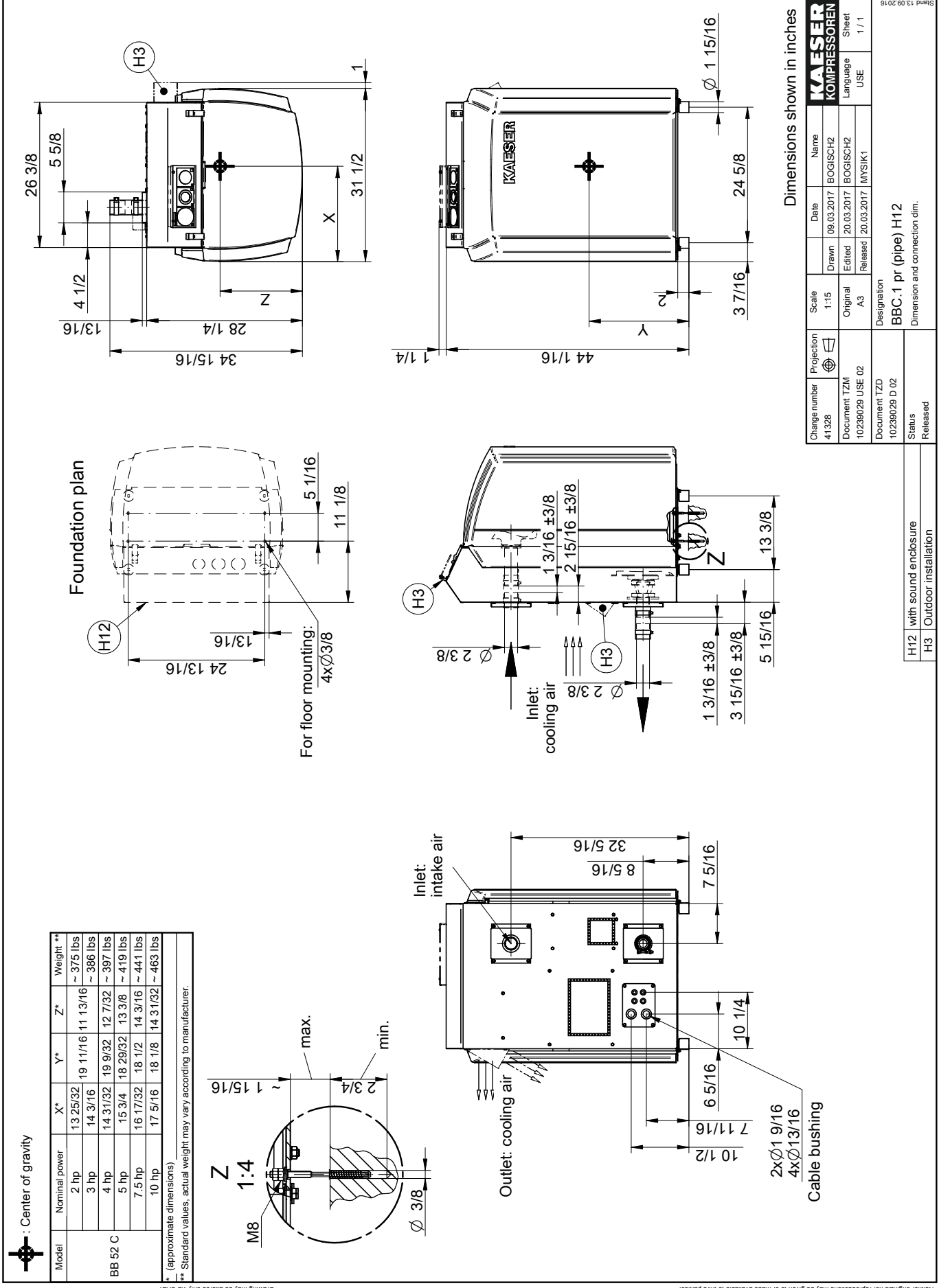

Drawings remain our exclusive property. Neither originals nor reproductions may be given to or made available to third parties. Copies or any other reproductions, including storage, treatment and distribution by use of electronic systems is not allowed for any other than the agreed upon purpose. This is restricted only for the agreed upon purpose.

13.2.2 BB 69 C pr, BB 89 C pr

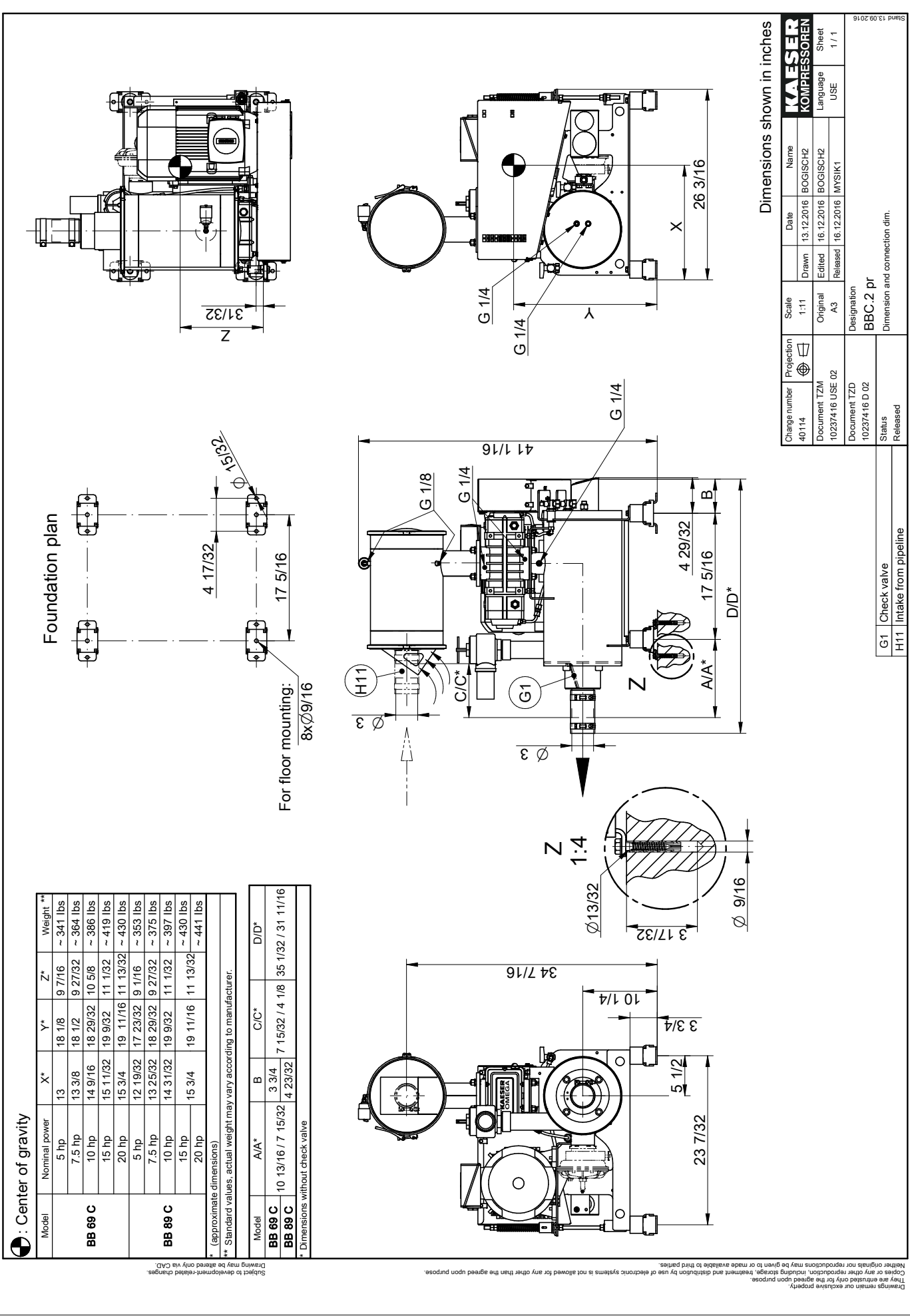

Center of gravity

Model	Nominal power	A/A***	X*	Y*	Z*	Weight**
BB 68 C	5 hp	6 5/16 / 2 15/16	15 11/32	23 5/8	16 17/32	~ 628 lbs
	7.5 hp		15 3/4	24 1/32	16 15/16	~ 650 lbs
	10 hp		16 5/32	24 19/32	17 5/16	~ 705 lbs
	15 hp		16 17/32	23 7/23	16 15/16	~ 716 lbs
	20 hp		15 11/32	23 5/8	17 5/16	~ 639 lbs
BB 88 C	5 hp	6 5/16 / 2 15/16	15 3/4	23 7/32	16 15/16	~ 661 lbs
	7.5 hp		16 5/32	23 5/8	17 5/16	~ 683 lbs
	10 hp		16 15/16	24 19/32	17 5/16	~ 716 lbs
	15 hp		16 5/32	23 5/8	17 5/16	~ 683 lbs
	20 hp		16 15/16	24 19/32	17 23/32	~ 727 lbs

* (approximate dimensions)
** Standard values, actual weight may vary according to manufacturer.
*** Dimensions without check valve

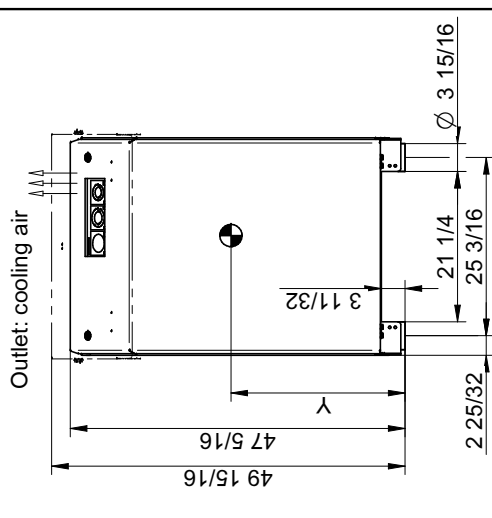
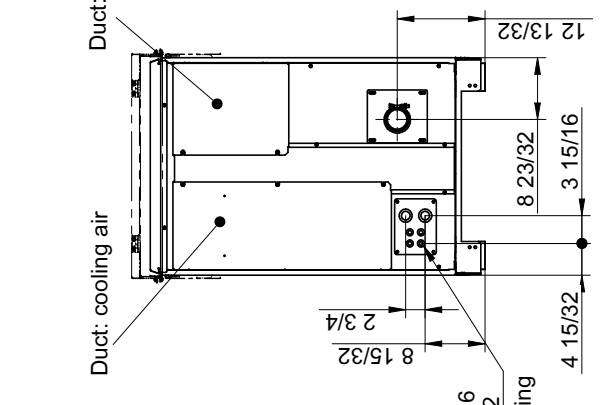
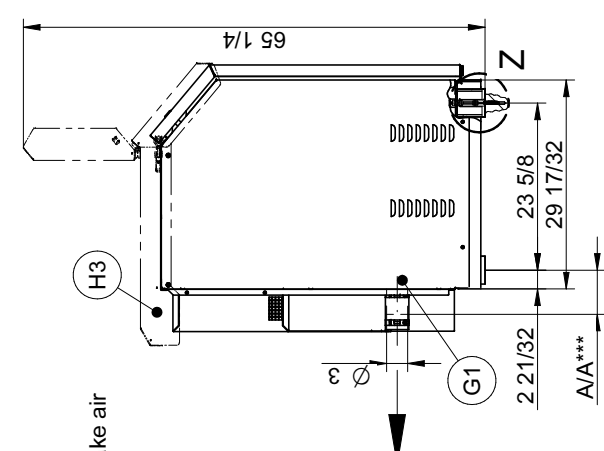
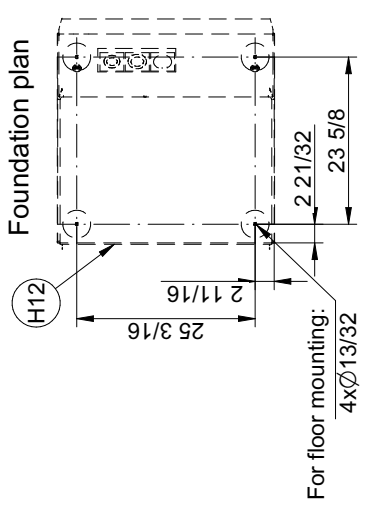
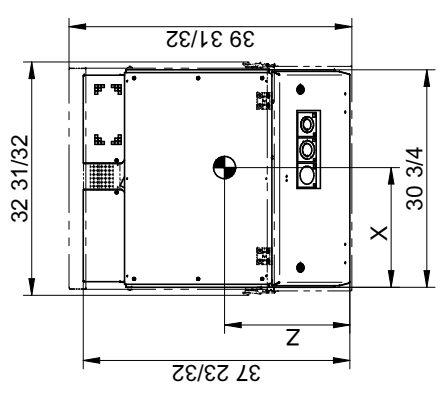
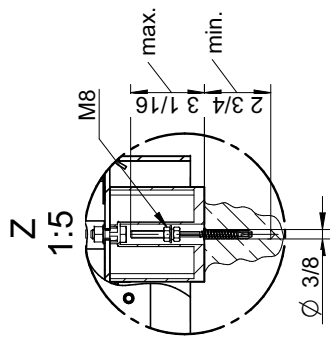

Dimensions shown in inches

Change number	Projection	Scale	Date	Name
35916	1:17	1:17	17.10.2014	GRIEBSCH1
Document TZM/10237725 USE 01	Original	Original	02.02.2015	MYSIK1
Document TZD/10237725 USE 01	A3	A3	03.02.2015	MYSIK1

Designation: BBC.2 pr H12
Dimension and connection dim.

Language	Sheet
USE	1 / 1

Change number	Status
10237725 D 01	Released

Designation	Released
H12 with sound enclosure	
G1 Check valve	
H3 Outdoor installation	

Drawings remain our exclusive property. Neither originals nor reproductions may be given to or made available to third parties. Copies or any other reproductions, including storage, treatment and distribution by use of electronic systems is not allowed for any other than the agreed upon purpose. This is restricted only for the agreed upon purpose. Drawing may be altered only via CAD. Subject to development-related changes.

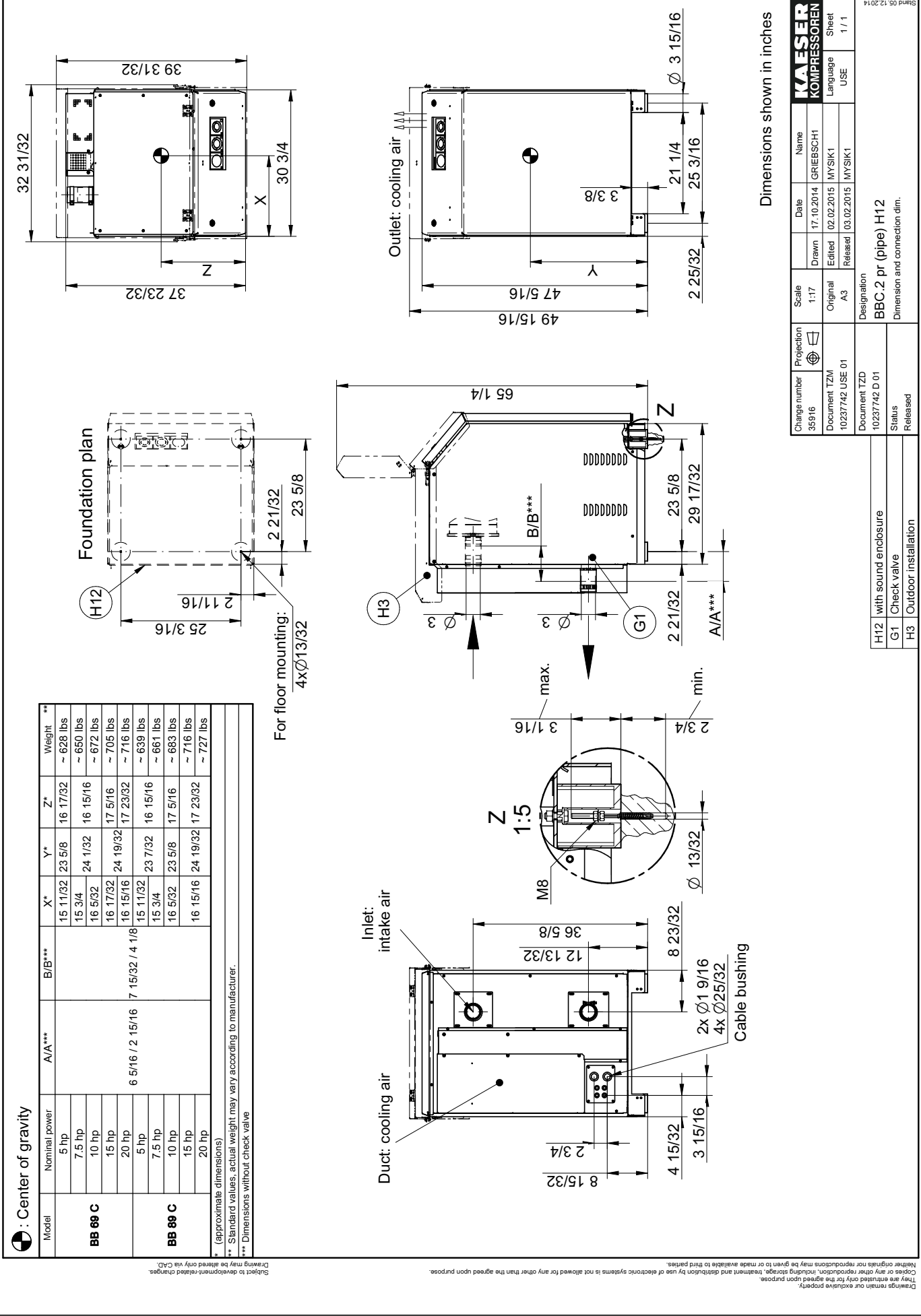

Model	Normal power	A/A***	B/B***	X*	Y*	Z*	Weight**
BB 68 C	5 hp			15 11/32	23 5/8	16 17/32	~ 628 lbs
	7.5 hp			15 3/4	24 1/32	16 15/16	~ 650 lbs
	10 hp			16 5/32	24 19/32	17 5/16	~ 672 lbs
	15 hp			16 17/32	24 19/32	17 5/16	~ 705 lbs
	20 hp			16 15/16	23 7/32	16 15/16	~ 716 lbs
BB 88 C	5 hp	6 5/16 / 2 15/16	7 15/32 / 4 1/8	15 11/32	23 7/32	16 15/16	~ 639 lbs
	7.5 hp			15 3/4	23 5/8	17 5/16	~ 661 lbs
	10 hp			16 5/32	23 5/8	17 5/16	~ 683 lbs
	15 hp			16 15/16	24 19/32	17 23/32	~ 716 lbs
	20 hp			16 15/16	24 19/32	17 23/32	~ 727 lbs

* (approximate dimensions)
** Standard values, actual weight may vary according to manufacturer.
*** Dimensions without check valve

Change number	Projection	Scale	Date	Name
35916		1:17	17.10.2014	GRIEBSCH1
Document TZM/10237742 USE 01		Original	02.02.2015	MYSIK1
Document TZD/10237742 USE 01		A3	03.02.2015	MYSIK1

Change number	Projection	Scale	Date	Name
35916		1:17	17.10.2014	GRIEBSCH1
Document TZM/10237742 USE 01		Original	02.02.2015	MYSIK1
Document TZD/10237742 USE 01		A3	03.02.2015	MYSIK1

Designation	Sheet
BBC.2 pr (pipe) H12	1 / 1
Dimension and connection dim.	1 / 1

Drawings remain our exclusive property. Neither originals nor reproductions may be given to or made available to third parties. Copies or any other reproductions, including storage, treatment and distribution by use of electronic systems is not allowed for any other than the agreed upon purpose. Drawing may be altered only via CAD. Subject to development-related changes.

13.3 Sound emission

The values for sound pressure levels and sound power levels are provided in the tables below:
Each table discusses one model.

The values applicable to the machine result from the combination of the blower block speed and the differential pressure.

If the texts of the tables are not provided in the chosen language, a translation can be found here.

Table legend	
a)	Type
b)	Without sound enclosure
c)	With sound enclosure
d)	Blower block speed
e)	Pressure differential
f)	Sound pressure level
g)	Sound power level

Tab. 46 Sound emission - legend

d) block speed [min ⁻¹]	a) B52C		b) without sound enclosure		c) with sound enclosure	
	e) pressure differential		f) sound level	g) sound power level	f) sound level	g) sound power level
	[mbar]	[psi]	[dB(A)]	[dB(A)]	[dB(A)]	[dB(A)]
			± 3 dB(A)	± 3 dB(A)	± 3 dB(A)	± 3 dB(A)
1330	200	3	74	89	72	87
1330	300	4	74	88	72	87
1330	400	6	74	88	72	87
1420	200	3	74	89	72	87
1420	300	4	74	89	72	87
1420	400	6	74	89	72	87
1500	200	3	74	89	72	87
1500	300	4	74	89	72	87
1500	400	6	75	89	72	87
1500	500	7	81	95	72	87
1600	200	3	75	89	72	87
1600	300	4	74	89	72	87
1600	400	6	75	90	72	87
1600	500	7	81	95	72	87
1680	200	3	75	89	72	87
1680	300	4	75	89	72	87
1680	400	6	75	90	72	87
1680	500	7	81	96	72	87
1760	200	3	75	89	72	87
1760	300	4	75	89	72	87
1760	400	6	76	90	72	87
1760	500	7	81	96	72	87
1760	590	9	82	97	72	87
1880	200	3	75	90	72	87
1880	300	4	75	90	72	87
1880	400	6	76	91	72	87
1880	500	7	82	96	72	87
1880	590	9	82	97	72	87
2090	200	3	76	90	72	87
2090	300	4	76	90	72	87
2090	400	6	77	91	72	87
2090	500	7	82	97	72	87
2090	600	9	83	97	72	87
2210	200	3	76	90	72	87
2210	300	4	76	90	72	87
2210	400	6	77	92	72	87
2210	500	7	83	97	72	87
2210	600	9	83	98	72	87
2210	690	10	83	97	72	87
2470	200	3	76	91	72	87
2470	300	4	77	91	72	87
2470	400	6	78	93	72	87
2470	500	7	83	98	72	87
2470	600	9	84	98	72	87
2470	700	10	83	98	72	87
2600	200	3	77	91	72	87
2600	300	4	77	91	72	87
2600	400	6	79	93	72	87
2600	500	7	84	98	72	87
2600	600	9	84	98	72	87
2600	700	10	84	98	72	87
2750	200	3	77	91	72	87
2750	300	4	77	92	72	87
2750	400	6	79	94	72	87
2750	500	7	84	98	72	87
2750	600	9	84	99	72	87
2750	700	10	84	99	72	87
2750	800	12	84	99	72	87
2910	200	3	77	92	72	87
2910	300	4	78	92	72	87
2910	400	6	80	94	72	87
2910	500	7	84	99	72	87
2910	600	9	85	99	73	88
2910	700	10	84	99	72	87
2910	800	12	85	99	73	87
3260	200	3	78	92	72	87
3260	300	4	79	93	72	87
3260	400	6	81	95	72	87
3260	500	7	85	99	73	88

d) block speed [min ⁻¹]	a) B52C		b) without sound enclosure		c) with sound enclosure	
	e) pressure differential [mbar]	[psi]	f) sound level [dB(A)]	g) sound power level [dB(A)]	f) sound level [dB(A)]	g) sound power level [dB(A)]
			± 3 dB(A)	± 3 dB(A)	± 3 dB(A)	± 3 dB(A)
3260	600	9	85	100	73	88
3260	700	10	85	100	73	88
3260	800	12	85	100	73	88
3430	200	3	78	93	72	87
3430	300	4	79	94	72	87
3430	400	6	81	96	72	87
3430	500	7	85	100	73	88
3430	600	9	85	100	73	88
3430	700	10	85	100	73	88
3430	800	12	85	100	73	88
3430	890	13	86	101	74	89
3630	200	3	79	93	72	87
3630	300	4	80	94	72	87
3630	400	6	82	96	72	87
3630	500	7	86	100	74	89
3630	600	9	86	100	74	89
3630	700	10	86	100	74	89
3630	800	12	86	100	74	89
3630	900	13	87	101	75	90
3840	200	3	79	94	72	87
3840	300	4	80	95	72	87
3840	400	6	82	97	72	87
3840	500	7	86	100	74	89
3840	600	9	86	101	74	89
3840	700	10	86	101	74	89
3840	800	12	86	101	74	89
3840	900	13	87	102	75	90
4050	200	3	79	94	72	87
4050	300	4	81	95	72	87
4050	400	6	83	98	72	87
4050	500	7	86	101	74	89
4050	600	9	86	101	74	89
4050	700	10	86	101	74	89
4050	800	12	86	101	74	89
4050	900	13	88	102	76	91
4270	200	3	80	94	72	87
4270	300	4	81	96	72	87
4270	400	6	84	98	72	87
4270	500	7	86	101	74	89
4270	600	9	87	101	75	90
4270	700	10	87	101	75	90
4270	800	12	87	101	75	90
4270	900	13	88	103	76	91
4530	200	3	80	95	72	87
4530	300	4	82	96	72	87
4530	400	6	84	99	72	87
4530	500	7	87	101	75	90
4530	600	9	87	102	75	90
4530	700	10	87	102	75	90
4530	800	12	87	102	75	90
4530	900	13	88	103	76	91
4850	200	3	81	95	72	87
4850	300	4	83	97	72	87
4850	400	6	85	99	73	88
4850	500	7	87	102	75	90
4850	600	9	88	102	76	91
4850	700	10	87	102	75	90
4850	800	12	88	102	76	91
4850	890	13	88	102	76	91
5180	200	3	81	96	72	87
5180	300	4	84	98	72	87
5180	400	6	86	100	74	89
5180	500	7	87	102	75	90
5180	600	9	88	102	76	91
5180	700	10	88	102	76	91
5180	800	12	88	103	76	91
5480	200	3	82	97	72	87
5480	300	4	84	99	72	87
5480	400	6	86	101	74	89

d) block speed [min ⁻¹]	a) B52C		b) without sound enclosure		c) with sound enclosure	
	e) pressure differential		f) sound level	g) sound power level	f) sound level	g) sound power level
	[mbar]	[psi]	[dB(A)]	[dB(A)]	[dB(A)]	[dB(A)]
			± 3 dB(A)	± 3 dB(A)	± 3 dB(A)	± 3 dB(A)
5480	500	7	87	102	75	90
5480	600	9	88	103	76	91
5480	700	10	88	102	76	91
5800	200	3	83	97	72	87
5800	300	4	85	100	73	88
5800	400	6	87	101	75	90
5800	500	7	88	102	76	91
5800	600	9	89	103	77	92
5800	700	10	88	103	76	91
6170	200	3	83	98	72	87
6170	300	4	86	101	74	89
6170	400	6	87	102	75	90
6170	500	7	88	102	76	91
6170	600	9	89	103	77	92

a) BB69C			b) without sound enclosure		c) with sound enclosure	
d) block speed	e) pressure differential		f) sound level	g) sound power level	f) sound level	g) sound power level
[min ⁻¹]	[mbar]	[psi]	[dB(A)]	[dB(A)]	[dB(A)]	[dB(A)]
			± 3 dB(A)	± 3 dB(A)	± 3 dB(A)	± 3 dB(A)
2600	200	3	79	94	69	84
2600	300	4	79	94	69	84
2600	400	6	79	94	69	84
2600	500	7	79	94	69	84
2600	600	9	82	96	69	84
2600	700	10	82	97	69	84
2600	790	11	82	97	69	85
2750	200	3	79	94	69	84
2750	300	4	79	94	69	84
2750	400	6	79	94	69	84
2750	500	7	79	94	69	84
2750	600	9	82	97	69	84
2750	700	10	82	97	69	84
2750	790	11	82	97	69	84
3260	200	3	79	94	69	84
3260	300	4	79	94	69	84
3260	400	6	79	94	69	84
3260	500	7	79	94	69	84
3260	600	9	82	97	69	84
3260	700	10	82	97	69	84
3260	800	12	82	97	69	84
3260	890	13	82	97	69	84
3430	200	3	79	94	69	84
3430	300	4	79	94	69	84
3430	400	6	79	94	69	84
3430	500	7	79	94	69	84
3430	600	9	82	97	69	84
3430	700	10	82	97	69	84
3430	800	12	82	97	69	84
3430	890	13	82	97	69	84
3630	200	3	80	94	69	84
3630	300	4	80	94	69	84
3630	400	6	80	94	69	84
3630	500	7	80	94	69	84
3630	600	9	82	97	69	84
3630	700	10	82	97	69	84
3630	800	12	82	97	69	84
3630	900	13	82	97	69	84
3840	200	3	80	94	69	84
3840	300	4	80	94	69	84
3840	400	6	80	94	69	84
3840	500	7	80	94	69	84
3840	600	9	83	97	69	84
3840	700	10	83	97	69	84
3840	800	12	83	97	69	84
3840	900	13	83	97	69	84
3840	950	14	83	97	69	84
4050	200	3	80	95	69	84
4050	300	4	80	95	69	84
4050	400	6	80	95	69	84
4050	500	7	80	95	69	84
4050	600	9	83	98	69	84
4050	700	10	83	98	69	84
4050	800	12	83	98	69	84
4050	900	13	83	98	69	84
4050	950	14	83	98	69	84
4270	200	3	80	95	69	84
4270	300	4	80	95	69	84
4270	400	6	80	95	69	84
4270	500	7	80	95	69	84

a) BB69C			b) without sound enclosure		c) with sound enclosure	
d) block speed	e) pressure differential		f) sound level	g) sound power level	f) sound level	g) sound power level
[min ⁻¹]	[mbar]	[psi]	[dB(A)]	[dB(A)]	[dB(A)]	[dB(A)]
			± 3 dB(A)	± 3 dB(A)	± 3 dB(A)	± 3 dB(A)
4270	600	9	83	98	69	84
4270	700	10	83	98	69	84
4270	800	12	83	98	69	84
4270	900	13	83	98	69	84
4270	950	14	83	98	69	84
4530	200	3	81	95	69	84
4530	300	4	81	95	69	84
4530	400	6	81	95	69	84
4530	500	7	81	95	69	84
4530	600	9	84	98	69	84
4530	700	10	84	99	69	84
4530	800	12	84	99	69	84
4530	900	13	84	99	69	84
4530	990	14	84	99	69	84
4850	200	3	81	96	69	84
4850	300	4	81	96	69	84
4850	400	6	81	96	69	84
4850	500	7	81	96	69	84
4850	600	9	84	99	69	84
4850	700	10	85	100	69	84
4850	800	12	85	100	69	85
4850	900	13	85	100	69	85
4850	1000	15	85	100	69	85
5180	200	3	82	97	69	85
5180	300	4	82	97	69	85
5180	400	6	82	97	69	85
5180	500	7	82	97	69	85
5180	600	9	85	99	69	85
5180	700	10	86	101	69	85
5180	800	12	86	101	70	85
5180	900	13	86	101	70	85
5180	1000	15	86	101	70	85
5480	200	3	83	97	70	85
5480	300	4	83	97	70	85
5480	400	6	83	97	70	85
5480	500	7	83	97	70	85
5480	600	9	85	100	70	85
5480	700	10	87	102	70	85
5480	800	12	87	102	70	85
5480	900	13	87	102	70	85
5480	1000	15	87	102	70	85
5800	200	3	83	98	70	85
5800	300	4	83	98	70	85
5800	400	6	83	98	70	85
5800	500	7	83	98	70	85
5800	600	9	86	101	70	85
5800	700	10	88	103	72	87
5800	800	12	88	103	72	87
5800	900	13	88	103	72	87
5800	1000	15	89	103	72	87

d) block speed	a) BB89C		b) without sound enclosure		c) with sound enclosure	
	e) pressure differential		f) sound level	g) sound power level	f) sound level	g) sound power level
	[min ⁻¹]	[mbar]	[psi]	[dB(A)]	[dB(A)]	[dB(A)]
			± 3 dB(A)	± 3 dB(A)	± 3 dB(A)	± 3 dB(A)
2600	200	3	80	95	69	84
2600	300	4	80	95	69	84
2600	400	6	80	95	69	84
2600	500	7	80	95	69	84
2600	600	9	82	96	69	84
2600	700	10	83	98	69	84
2600	800	12	83	98	70	85
2750	200	3	80	95	69	84
2750	300	4	80	95	69	84
2750	400	6	80	95	69	84
2750	500	7	80	95	69	84
2750	600	9	82	97	69	84
2750	700	10	83	98	69	84
2750	800	12	83	98	70	85
3260	200	3	79	94	69	84
3260	300	4	79	94	69	84
3260	400	6	79	94	69	84
3260	500	7	79	94	69	84
3260	600	9	83	97	69	84
3260	700	10	83	98	69	84
3260	800	12	83	98	69	84
3260	890	13	83	98	69	84
3430	200	3	79	94	69	84
3430	300	4	79	94	69	84
3430	400	6	79	94	69	84
3430	500	7	79	94	69	84
3430	600	9	83	98	69	84
3430	700	10	83	98	69	84
3430	800	12	83	98	69	84
3430	900	13	83	98	69	84
3430	950	14	81	95	69	84
3630	200	3	79	94	69	84
3630	300	4	79	94	69	84
3630	400	6	79	94	69	84
3630	500	7	79	94	69	84
3630	600	9	83	98	69	84
3630	700	10	83	98	69	84
3630	800	12	83	98	69	84
3630	900	13	83	98	69	84
3630	950	14	81	96	69	84
3840	200	3	79	94	69	84
3840	300	4	79	94	69	84
3840	400	6	79	94	69	84
3840	500	7	79	94	69	84
3840	600	9	83	98	69	84
3840	700	10	83	98	69	84
3840	800	12	83	98	69	84
3840	900	13	83	98	69	84
3840	990	14	82	96	69	84
4050	200	3	79	94	69	84
4050	300	4	79	94	69	84
4050	400	6	79	94	69	84
4050	500	7	79	94	69	84
4050	600	9	84	98	69	84
4050	700	10	84	98	69	84
4050	800	12	84	98	69	84
4050	900	13	84	98	69	84
4050	1000	15	82	97	69	84
4270	200	3	80	94	69	84
4270	300	4	80	94	69	84

a) BB89C			b) without sound enclosure		c) with sound enclosure	
d) block speed	e) pressure differential		f) sound level	g) sound power level	f) sound level	g) sound power level
[min ⁻¹]	[mbar]	[psi]	[dB(A)]	[dB(A)]	[dB(A)]	[dB(A)]
			± 3 dB(A)	± 3 dB(A)	± 3 dB(A)	± 3 dB(A)
4270	400	6	80	94	69	84
4270	500	7	80	94	69	84
4270	600	9	84	99	69	84
4270	700	10	84	99	69	84
4270	800	12	84	99	69	84
4270	900	13	84	99	69	84
4270	1000	15	83	98	69	84
4530	200	3	80	95	69	84
4530	300	4	80	95	69	84
4530	400	6	80	95	69	84
4530	500	7	80	95	69	84
4530	600	9	84	99	69	84
4530	700	10	84	99	69	84
4530	800	12	84	99	69	84
4530	900	13	84	99	69	84
4530	1000	15	84	98	69	84
4850	200	3	81	95	69	84
4850	300	4	81	95	69	84
4850	400	6	81	95	69	84
4850	500	7	81	95	69	84
4850	600	9	84	99	69	84
4850	700	10	85	100	69	84
4850	800	12	85	100	69	84
4850	900	13	85	100	69	84
4850	1000	15	85	99	69	84
5180	200	3	81	96	69	84
5180	300	4	81	96	69	84
5180	400	6	81	96	69	84
5180	500	7	81	96	69	84
5180	600	9	85	99	69	84
5180	700	10	86	101	69	84
5180	800	12	86	101	69	85
5180	900	13	86	101	69	85
5180	950	14	86	100	69	84
5480	200	3	82	97	69	84
5480	300	4	82	97	69	84
5480	400	6	82	97	69	84
5480	500	7	82	97	69	84
5480	600	9	85	100	69	84
5480	700	10	87	102	69	84
5480	800	12	87	102	70	85
5480	900	13	87	102	70	85
5800	200	3	84	98	69	84
5800	300	4	84	98	69	84
5800	400	6	84	98	69	84
5800	500	7	84	98	69	84
5800	600	9	85	100	69	84
5800	700	10	88	103	69	84
5800	800	12	88	103	70	85

13.4 Drive motor electrical diagram

The connection diagram is a common diagram for the main voltage and frequency.

1 2 3 4 5 6 7 8

drive motor 6 terminals

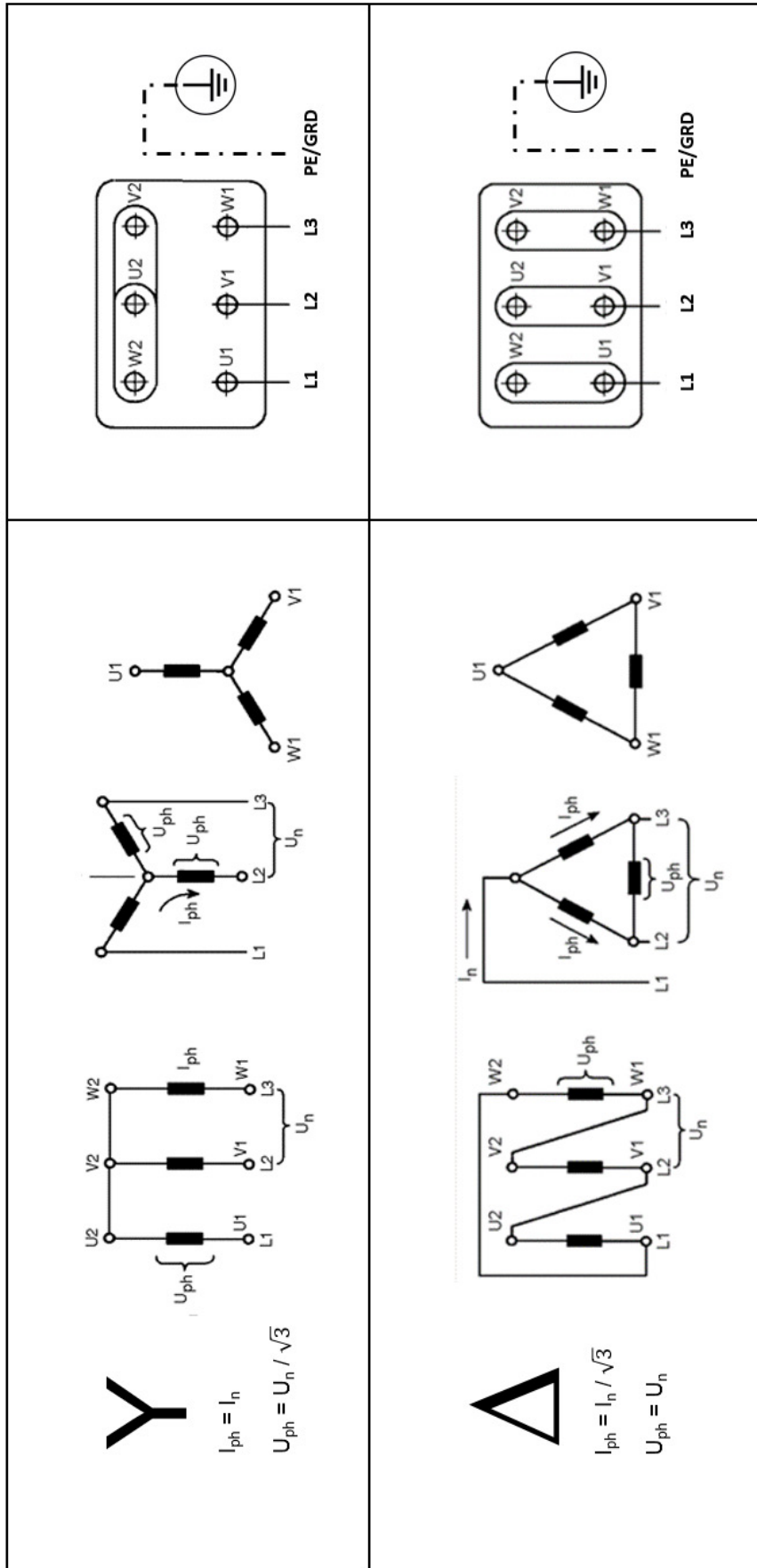

c	Datum	16.10.2018	=	SX.B.SSG-03022.03	page	2
	Bearbeiter	M.Zeeh				
b	Geprüft	M.Zeeh	+	SX.B.SSG-03022.03	7	Bl.
a	Norm					
Ersatz durch:			Ersatz für:			
<p>Wiring Diagram drive motor 6 terminals Wiring variants 6 terminals</p>						

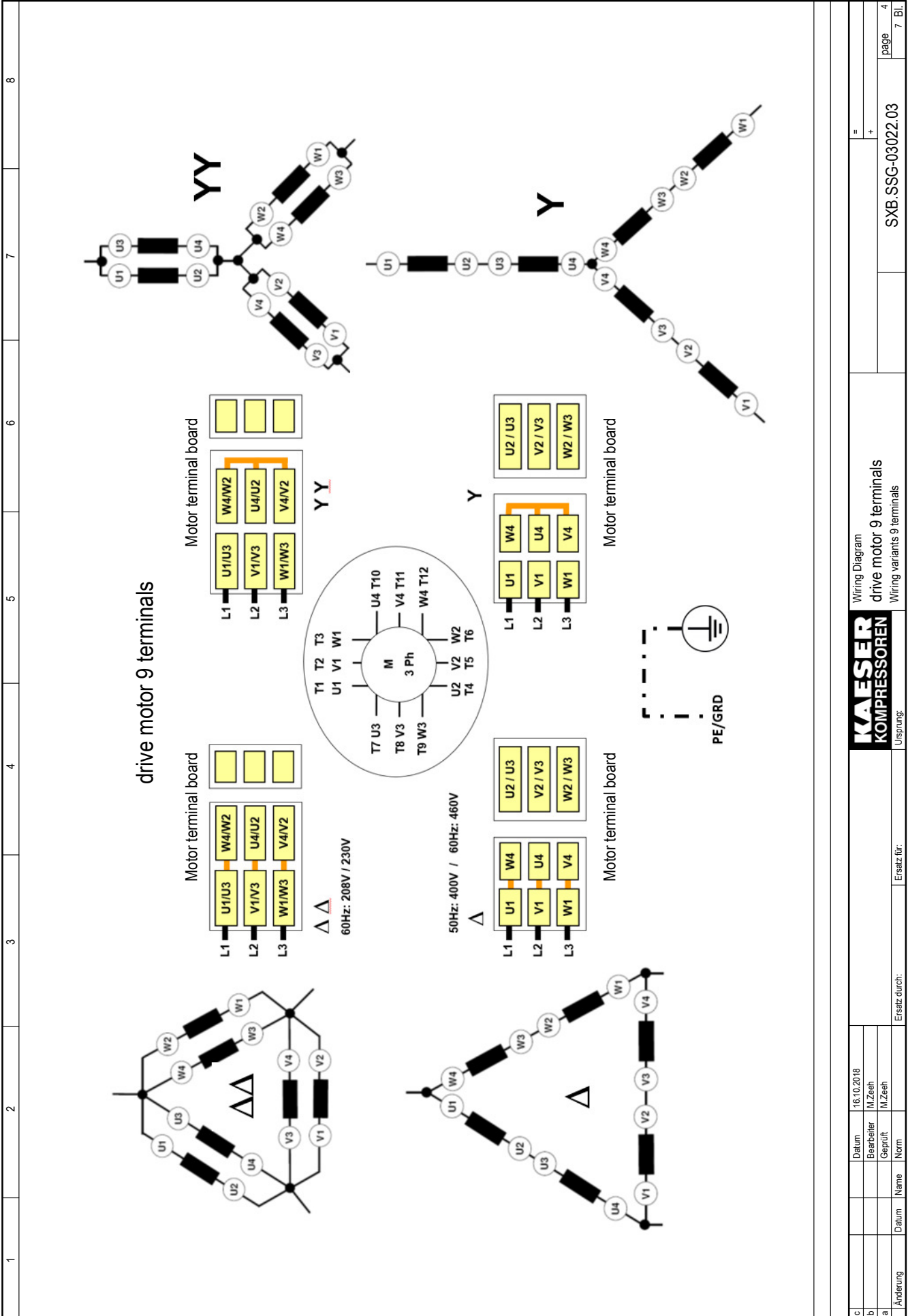

Kaeser KOMPRESSOREN		Wiring Diagram		=	
drive motor 9 terminals		drive motor 9 terminals		+	
Wiring variants 9 terminals		Wiring variants 9 terminals		SX.B.SSG-03022.03	
Ursprung:		Ersatz für:		page 4	
Datum 16.10.2018		Name		7 Bl.	
Bearbeiter M.Zeeh		Datum			
Geprüft M.Zeeh		Name			
Norm		Datum			
Änderung		Name			

1		2		3		4		5		6		7		8	
drive motor 12 terminals															
voltage	50Hz power supply						60Hz power supply								
	Y/D			direct on line start			Y/D			direct on line start					
200V DD - 50Hz	200V YY/DD			200V DD											
200V DD - 60Hz							200V YY/DD			200V DD					
208V DD - 60Hz							208V YY/DD			208V DD					
220V DD - 60Hz							220V YY/DD			220V DD					
230V DD - 60Hz							230V YY/DD			230V DD					
380V D - 50Hz	380V Y/D			380V D											
400V D - 50Hz	400V Y/D			400V D											
420V D - 50Hz	420V Y/D			420V D											
420V D - 60Hz							420V Y/D			420V D					
440V D - 60Hz							440V Y/D			440V D					
460V D - 60Hz							460V Y/D			460V D					
480V D - 60Hz							480V Y/D			480V D					

c		Datum		M/Zeich		=	
b		Bearbeiter		M/Zeich		+	
a		Geprüft		M/Zeich		SX.B.SSG-03022.03	
Änderung		Datum		Name		page 5	
		Ersatz durch:		Ersatz für:		7 Bl.	

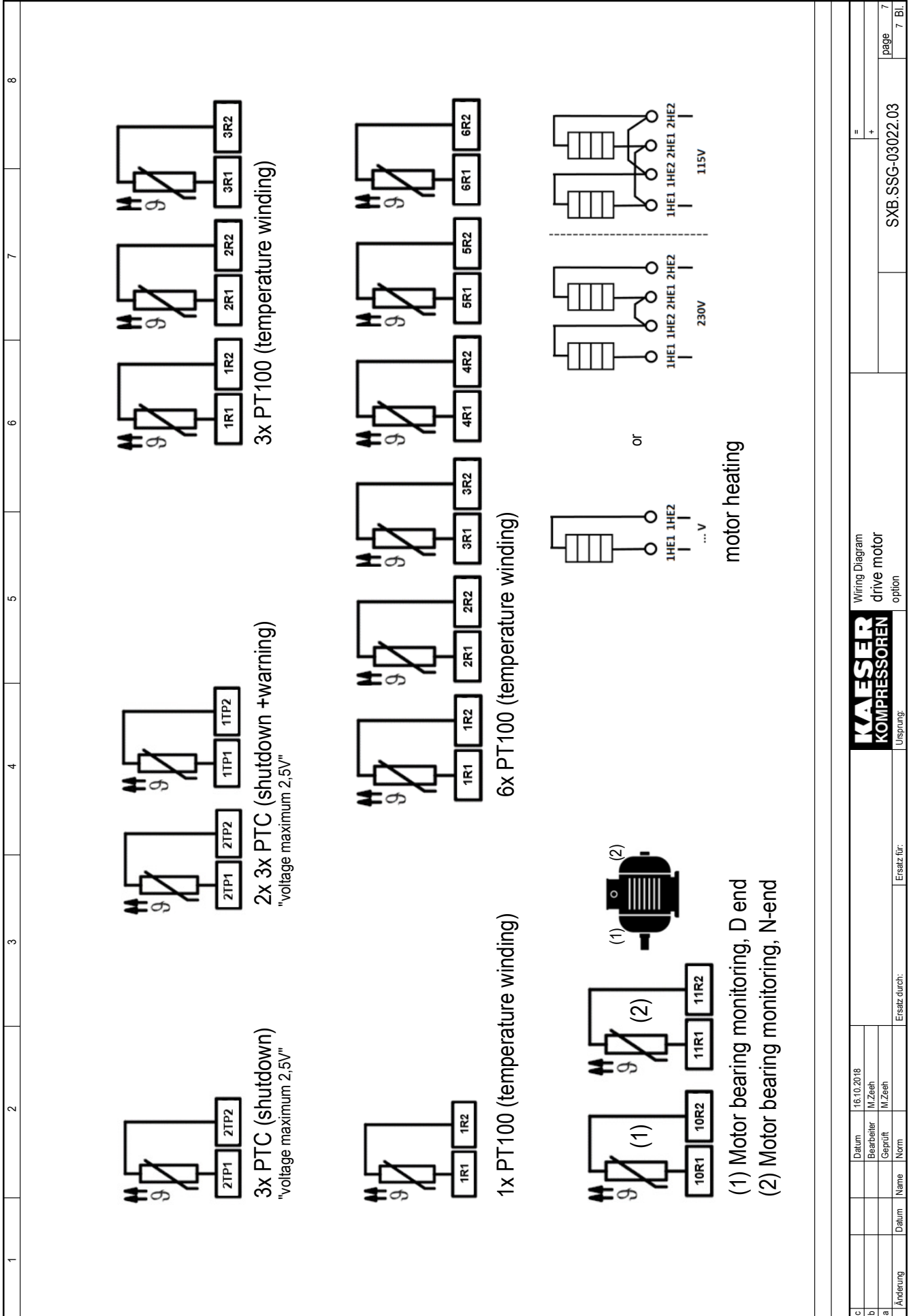

c	Datum	16.10.2018	=
b	Bearbeiter	M.Zeesh	+
a	Geprüft	M.Zeesh	
	Name		
	Datum		
	Ersatz durch:		
	Ursprung:		
	Wiring Diagram		
	drive motor		
	option		
		SXB.SSG-03022.03	page 7
			7 Bl.

13.5 Electrical diagrams for options

Electrical diagrams for the options available for your machine are given in the following.

13.5.1 Option C9

Pressure switch wiring diagram

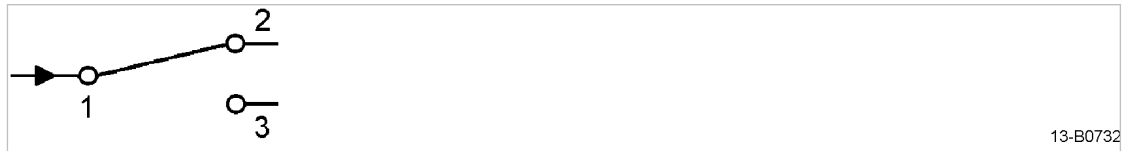

13-B0732

Fig. 41 Pressure switch wiring diagram

- ① Supply
- ② Break contact
- ③ Make contact

13.5.2 Option C10

Speed monitor wiring diagram

Sensor / evaluation device

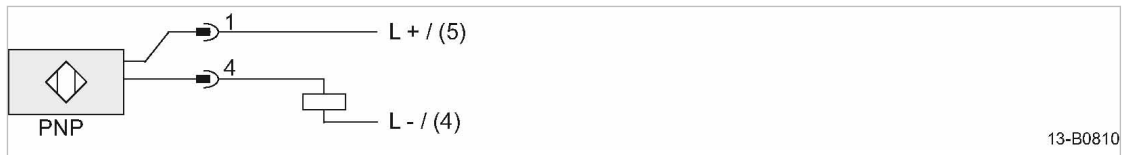

13-B0810

Fig. 42 Speed monitor wiring diagram

13.5.3 Option C13

Temperature gauge switch wiring diagram

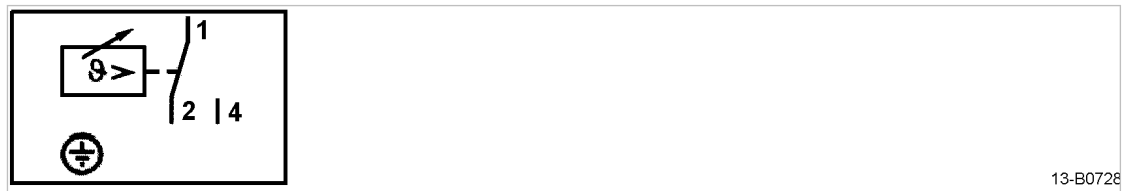

13-B0728

Fig. 43 Temperature gauge switch wiring diagram

13.5.4 Option C14
Pressure sensor connections

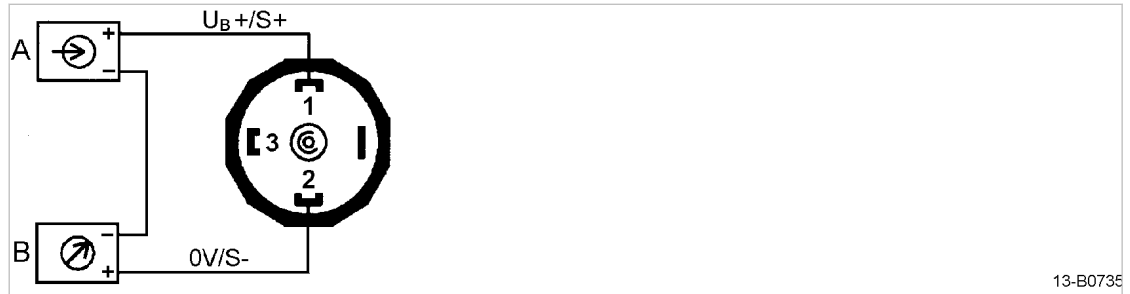

Fig. 44 Pressure sensor connections

- (A) Power supply
- (B) Evaluation/display

13.5.5 Option C19
Thermostat wiring diagram

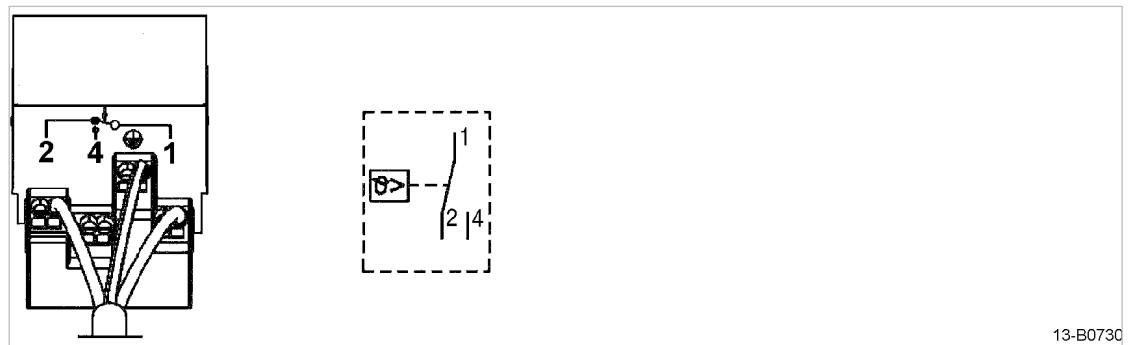

Fig. 45 Thermostat wiring diagram

13.5.6 Option F5 Filter pressure differential switch wiring diagram



13-B0737

Fig. 46 Filter pressure differential switch wiring diagram

13.5.7 Option H2 Auxiliary heater wiring diagram

13.5.7.1 BB 52 C pr

1	2	3	4	5	6	7	8	
<p style="text-align: center;">Schaltungsunterlagen Electrical diagrams</p> <p style="text-align: center;">Gebläse/Blower</p> <p style="text-align: center;">Heizung/Heater - 208...230V 50/60Hz</p> <p style="text-align: center;">TT/TN-Netz mit geerdetem Sternpunkt TT/TN power supply with common point grounding</p>								
<p style="text-align: center;">Hersteller: KAESER KOMPRESSOREN GmbH Postfach 2143 96410 Coburg</p>								
<p>Dieses Dokument beinhaltet einen Sammelplan für alle hier aufgeführten Anlagentypen, Netzspannungen und Frequenzen. Unter welchen tatsächlichen Spannungen, Frequenzen und Umgebungsbedingungen die jeweilige Anlage ausschließlich betrieben werden darf, ist dem Typenschild der Anlage sowie der beiliegenden Betriebsanleitung zu entnehmen.</p> <p>The document gives collective information on power supply voltages and frequencies for all machines. The voltage and frequency and local conditions under which any particular machine may be used are given on the nameplate of the machine and in the accompanying service manual.</p> <p>Die Schaltungsunterlagen bleiben unser ausschließliches Eigentum. Sie werden nur zu dem vereinbarten Zweck anvertraut. Kopien oder sonstige Vervielfältigungen einschließlich der Speicherung, Verarbeitung und Verbreitung unter Verwendung elektronischer Systeme dürfen nur zu dem vereinbarten Zweck angefertigt werden. Weder Originale noch Vervielfältigungen dürfen Dritten ausgehändigt oder in sonstiger Weise zugänglich gemacht werden.</p> <p>The drawings remain our exclusive property. They are entrusted only for the agreed purpose. Copies or any other reproductions, including storage, treatment and dissemination by use of electronic systems must not be made for any other than the agreed purpose. Neither originals nor reproductions must be forwarded or otherwise made accessible to third parties.</p>								
c	Datum	17.01.2012	D					=
b	Bearbeiter	M.Zeesh						+
a	Geprüft	M.Zeesh						
A	Änderung	Datum	Name	Norm	Ersatz durch:	Ersatz für:	Blatt 1 1 Bl.	
						Heizung/Heater	SXB.DSG-03014.00	
				KAESER KOMPRESSOREN				
				Deckblatt				
				Heizung/Heater				
				Ursprung: SSS-0081				

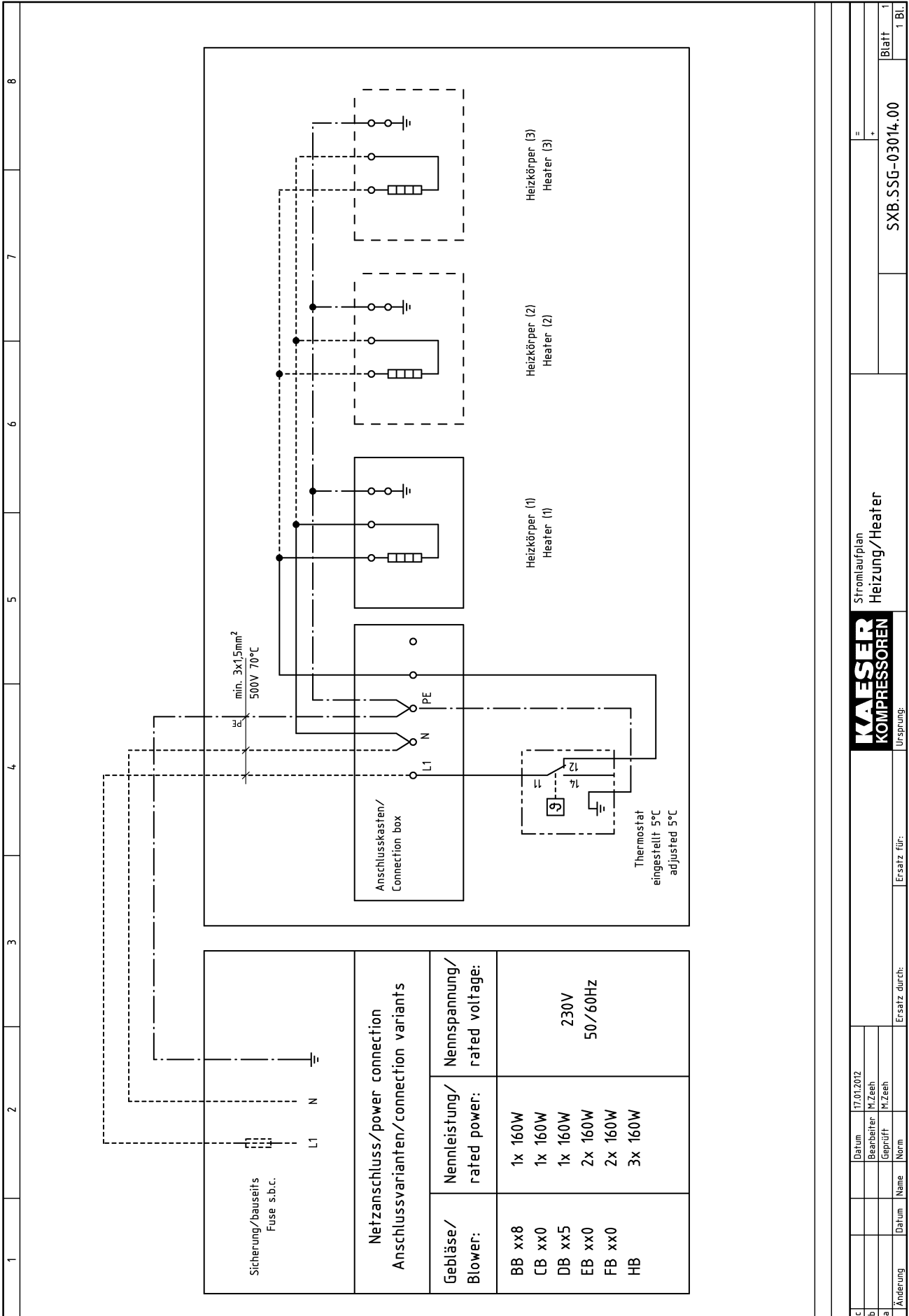

c	Datum	17.01.2012	Ersatz durch:		Ersatz für:		Stromlaufplan Heizung/Heater		=	
b	Bearbeiter	M. Zeeh	Ersatz durch:		Ersatz für:		Stromlaufplan Heizung/Heater		+	
a	Geprüft	M. Zeeh	Ersatz durch:		Ersatz für:		Stromlaufplan Heizung/Heater		1 Blatt	
Änderung	Datum	Name	Ersatz durch:		Ersatz für:		Stromlaufplan Heizung/Heater		1 Bl.	
			Ersatz durch:		Ersatz für:		Stromlaufplan Heizung/Heater		SX.B.SSG-03014.00	

13.5.7.2 BB 69 C pr, BB 89 C pr

1	2	3	4	5	6	7	8
<p>Schaltungsunterlagen Electrical diagrams Gebläse/Blower Heizung/Heater – 110...265V 50/60Hz TT/TN-Netz mit geerdetem Sternpunkt TT/TN power supply with common point grounding</p>							
<p>Dieses Dokument beinhaltet einen Sammelplan für alle hier aufgeführten Anlagentypen, Netzspannungen und Frequenzen. Unter welchen tatsächlichen Spannungen, Frequenzen und Umgebungsbedingungen die jeweilige Anlage ausschließlich betrieben werden darf, ist dem Typenschild der Anlage sowie der beiliegenden Betriebsanleitung zu entnehmen.</p>							
<p>The document gives collective information on power supply voltages and frequencies for all machines. The voltage and frequency and local conditions under which any particular machine may be used are given on the nameplate of the machine and in the accompanying service manual.</p>							
<p>Die Schaltungsunterlagen bleiben unser ausschließliches Eigentum. Sie werden nur zu dem vereinbarten Zweck anvertraut. Kopien oder sonstige Vervielfältigungen einschließlich der Speicherung, Verarbeitung und Verbreitung unter Verwendung elektronischer Systeme dürfen nur zu dem vereinbarten Zweck angefertigt werden. Weder Originale noch Vervielfältigungen dürfen Dritten ausgehändigt oder in sonstiger Weise zugänglich gemacht werden.</p>							
<p>The drawings remain our exclusive property. They are entrusted only for the agreed purpose. Copies or any other reproductions, including storage, treatment and dissemination by use of electronic systems must not be made for any other than the agreed purpose. Neither originals nor reproductions must be forwarded or otherwise made accessible to third parties.</p>							
<p>Hersteller: KAESER KOMPRESSOREN GmbH Postfach 2143 96410 Coburg</p>							
<p>Deckblatt Heizung/Heater</p>							
<p>KAESER KOMPRESSOREN Ursprung: SSS-0081</p>							
A Änderung		Datum		Name		Ersatz durch:	
		Datum		Name		Ersatz für:	
		17.01.2012		D			
b		Bearbeiter		M. Zeeh			
a		Geprüft		M. Zeeh			
		Norm				SXB.DSG-03013.00	
						Blatt 1	
						1 Bl.	

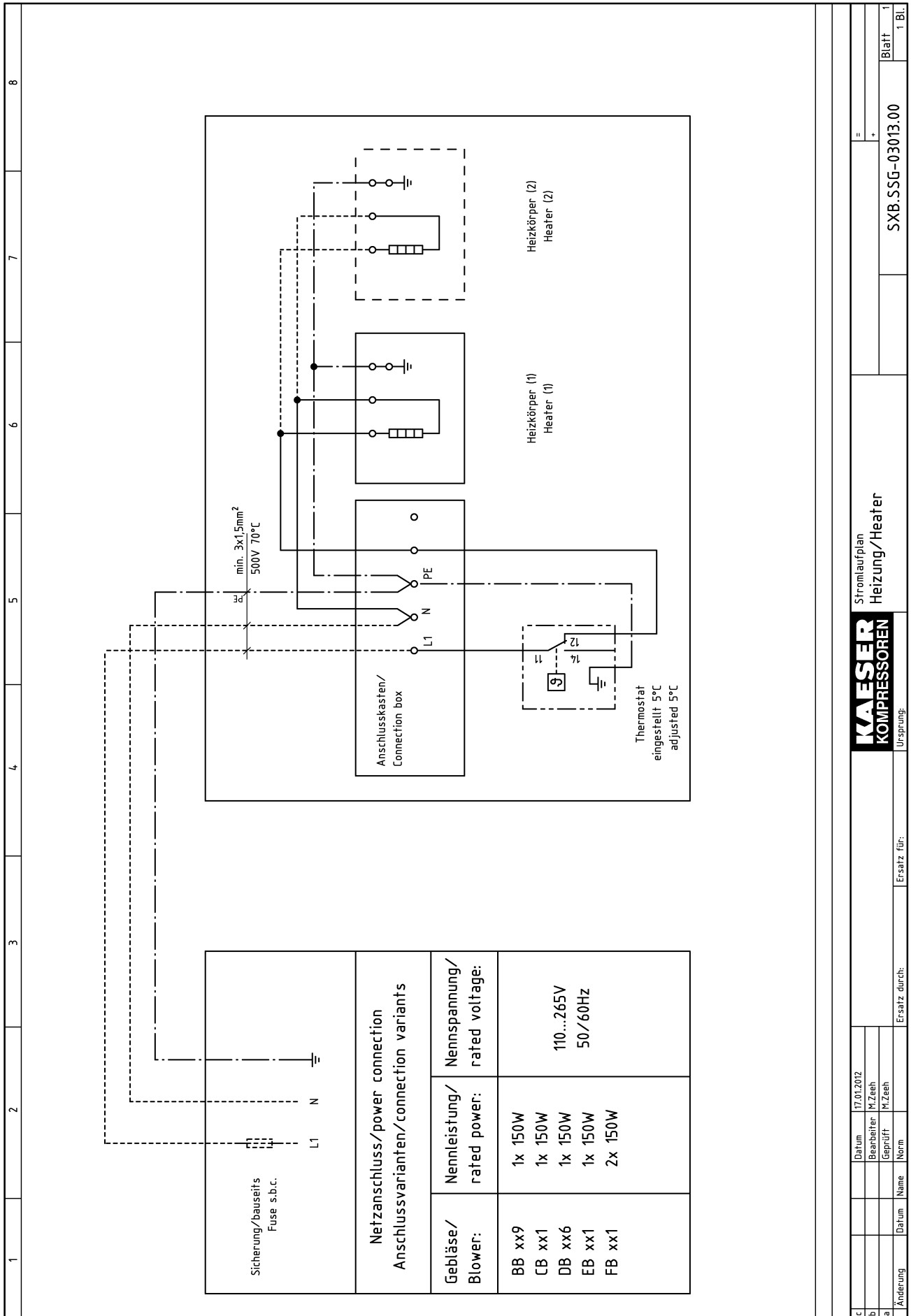

Sicherung/bauseits Fuse s.b.c.		L1 N
Netzanschluss/power connection Anschlussvarianten/connection variants		
Gebäuse/ Blower:	Nennleistung/ rated power:	Nennspannung/ rated voltage:
BB xx9	1x 150W	110...265V 50/60Hz
CB xx1	1x 150W	
DB xx6	1x 150W	
EB xx1	1x 150W	
FB xx1	2x 150W	

c	Datum	17.01.2012	Ersatz durch:	Ersatz für:	Stromlaufplan Heizung/Heater	=	+	SX.B.SSG-03013.00	Blatt 1 1 Bl.
b	Bearbeiter	M.Zeeh							
a	Geprüft	M.Zeeh							
Änderung	Datum	Name	Norm	Ursprung					

13.5.8 Option H12
Fan motor wiring diagram (sound enclosure)

Wiring diagram assignment is derived from the relevant connection data as per chapter 2.13.13.

13.5.8.1 Three-phase motor circuit

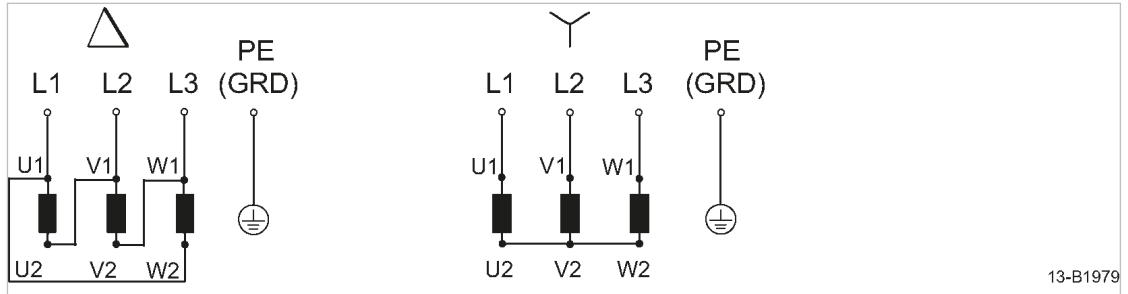

Fig. 47 Fan star-delta circuit diagram

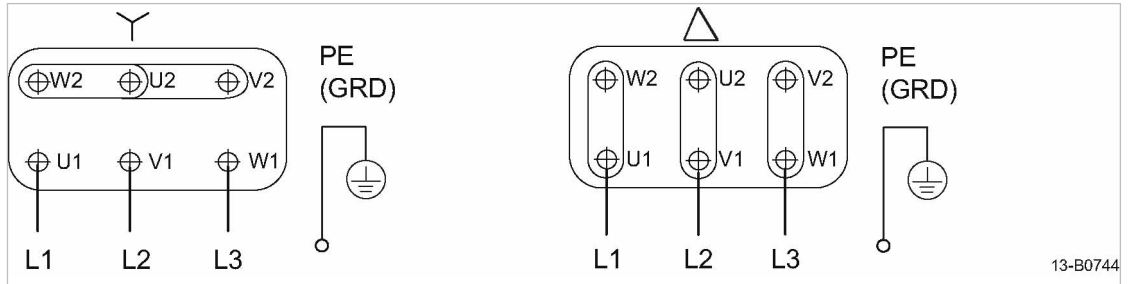

Fig. 48 Fan star-delta circuit diagram

13.5.8.2 AC motor circuit

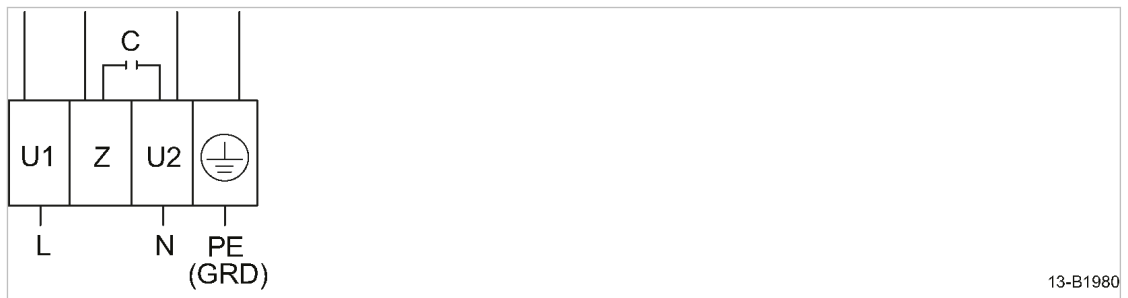

Fig. 49 Fan alternating current circuit diagram

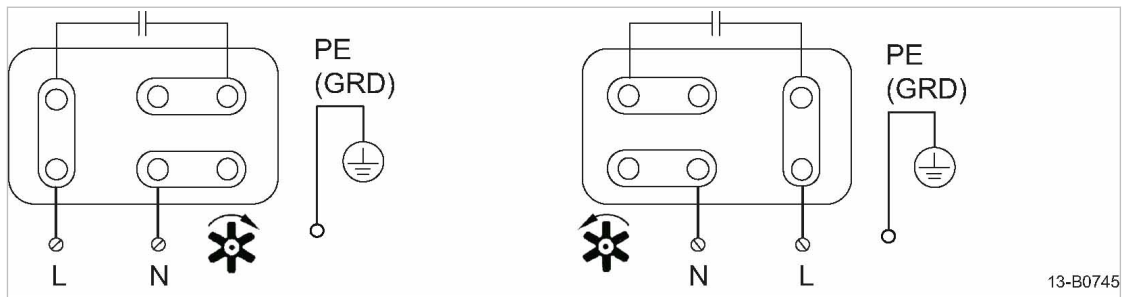

Fig. 50 Fan alternating current circuit diagram

13.6 Project planning data

