

SERVICE MANUAL

USE

Rotary Blower Package

Model: EB 290 C pr

Article No.: 882276.01570 – V02

Serial No.:

Table of Contents



Chapter - Page

1	Technical Specification	1 - 1
1.1	Rotary Blower Package	1 - 1
1.2	Sound Pressure Level, Sound Power Level	1 - 1
1.3	Electrical Connection	1 - 1
1.4	Lubricant Capacities	1 - 2
1.5	Lubricant Oil Filling	1 - 2
1.6	Recommended Lubricants	1 - 2
1.7	Designation	1 - 3
1.8	Installation Requirements	1 - 3
1.9	Dimensional Diagrams	1 - 3
1.10	Design Data (Diagrams)	1 - 4
2	Safety Regulations	2 - 5
2.1	Explanations of Symbols and References	2 - 5
2.2	General Notes on Accident Prevention Regulations	2 - 5
2.3	Accident Prevention Regulations	2 - 6
2.4	General References	2 - 6
2.5	Spare Parts	2 - 7
3	General	3 - 8
3.1	Correct Use	3 - 8
3.2	Copyright	3 - 8
4	Transport	4 - 9
4.1	Transport Instructions	4 - 9
4.2	Packaging	4 - 10
4.3	Temporary Storage	4 - 11
5	Construction and Principles	5 - 12
5.1	Principle of Compression	5 - 12
5.2	Short Description	5 - 12
6	Installation	6 - 14
6.1	Installation Requirements	6 - 14
6.2	Compressed air Connection	6 - 14
6.3	Electrical Connection	6 - 14
6.4	Lubricant Oil Filling	6 - 15
7	Putting into Operation	7 - 16
7.1	Points to be Observed	7 - 16
7.2	Starting Precautions	7 - 16
7.3	Direction of Rotation Check	7 - 17

Table of Contents



Chapter - Page

8	Operation	8 - 18
8.1	Starting and Stopping the Package	8 - 18
8.2	Action to be taken during a Fault	8 - 18
8.2.1	Abnormal running noises	8 - 18
8.2.2	Excessive blower temperature	8 - 19
8.2.3	Oil leaking into air chamber	8 - 19
8.2.4	Low inlet volume flow	8 - 19
9	Maintenance	9 - 20
9.1	Precautions to be Observed during Maintenance and Servicing	9 - 20
9.2	Regular Maintenance	9 - 20
9.3	Checking Drive Belt Tension	9 - 21
9.4	Changing the Drive Belts	9 - 21
9.5	Lubricating Oil Level Check and Top-Up	9 - 22
9.6	Lubricating Oil Change	9 - 22
9.7	Cleaning the Blower Package	9 - 23
9.8	Air filter changing	9 - 23
9.9	Greasing the Electric Motor	9 - 24
10	Spare Parts and After Sales Service	10 - 25
11	Appendix	11 - 26
11.1	Instructions on Electrical Connection	11 - 26
11.2	Maintenance Schedule	11 - 27
11.3	Safety information concerning contamination of compressors, blowers, vacuum pumps and components	11 - 28

Rotary Blower Package – Accessories

1 Technical Specification

1.1 Rotary Blower Package

Air flow capacity at maximum pressure difference.....	734	ICFM
Maximum rotary blower performance.....	61.5	BHP
Rotary blower speed	3530	rpm
Inlet pressure.....	14.7	psia
Outlet pressure.....	29.7	psia
Maximum pressure difference.....	15.0	psi
Temperature difference Δt	182	°F
Weight.....	1720	lbf
Weight with sound enclosure	2470	lbf

The safety valve, supplied with the unit, starts to blow off at the maximum permissible discharge pressure in order to protect the rotary blower package.

The data for special applications are to be found in the design data (diagrams).

1.2 Sound Pressure Level, Sound Power Level

Operational state of the rotary blower package:

Full load, the rotary blower package runs at: rated speed, outlet pressure, max. air flow capacity

Measurement conditions:

free field measurement

Measurement to CAGI/PNEUROP PN8 NTC 2.3:

Sound pressure level.....	-	dB (A)
Sound pressure level with sound enclosure.....	77	dB (A)
Sound power level.....	-	dB (A)
Sound power level with sound enclosure	94	dB (A)

1.3 Electrical Connection

Electric motor:

Rated power	60	HP
Rated speed	3560	rpm
Specification	IP 55	
Power supply	460	V 3 Ph
Frequency	60	Hz
Maximum rated current I_R	69.1	A

D-U-switch

Maximum mains fuse capacity (slowblow or class gl).....	100	A
---	-----	---

V-belt set:

Description XPZ 2030

Article No.: 893442.0

Sound enclosure fan motor:

See the fan electrical diagram in the attachment under "Installation Instructions".

1.4 Lubricant Capacities

Drive end 16.9 ± 15 % Oz.

Gear end 20.3 ± 15 % Oz.

1.5 Lubricant Oil Filling

Attention!

The rotary blower package is delivered with a full charge of lubricating oil.

Type of oil used: KAESER OMEGA FLUID-M 220

1.6 Recommended Lubricants

The use of mineral oils with high ageing resistance, high viscosity index, good oxidation stability and good demulsifying properties are recommended. They should comply with the minimum requirements placed on mineral oil type C by DIN 51517, Part 1.

The following oils should be used taking ambient temperatures and the resulting oil temperatures into account:

- Ambient temperature 5 °F to 105 °F - normal oil temperature 25 °F to 176 °F
Lube oil type C, CL, CLP 100 to DIN 51517
Viscosity at 105 °F 100 ± 10 mm²/s (CSA)
ISO – VG 100

Recommended sort: KAESER OMEGA FLUID - M 100 part no.: 892475.0
in 1 litre bottle part no.: 885891.00010
in 5 litre canister part no.: 885891.0

- Ambient temperature 25 °F to 140 °F - higher oil temperature 35 °F to 230 °F
Lube oil type C, CL, CLP 220 to DIN 51517
Viscosity at 105 °F 220 ± 22 mm²/s (CSA)
ISO – VG 220

Recommended sort: KAESER OMEGA FLUID - M 220 part no.: 892338.0
in 1 litre bottle part no.: 883816.00010
in 5 litre canister part no.: 883816.0

For extreme operational conditions

- Ambient temperature –10 °F to 105 °F – oil temperature –10 °F to 230 °F
Lube oil type PG 150 DIN 51502
Viscosity at 105 °F 138 mm²/s (CSA)

Recommended sort: KAESER OMEGA FLUID - S 150 part no.: 892193.0
in 1 litre bottle part no.: 863289.00010
in 5 litre canister part no.: 863289.0

- If temperatures above 230 °F are expected
Lube oil type PG 220
Viscosity at 105 °F 214 mm²/s (CSA)

Recommended sort: KAESER OMEGA FLUID - S 220 part no.: 891356.0
in 1 litre bottle part no.: 883816.00030
in 5 litre canister part no.: 883816.00020

Other types of oil available on request

Note: Higher oil temperatures can occur if:

- the ambient temperature is above 105 °F
- the blower is within a sound enclosure
- the blower is pressure operated with pressure differentials above 8.7 psi.
- the blower is vacuum operated with pressure differentials above 4.35 psi.

1.7 Designation

The nameplate of the package is located on the frame.
(see chapter 10 for nameplate illustration)

1.8 Installation Requirements

Minimum ambient temperature 5 °F

Maximum ambient temperature 105 °F

Install in a machine space or similar surroundings

1.9 Dimensional Diagrams

(see following page)

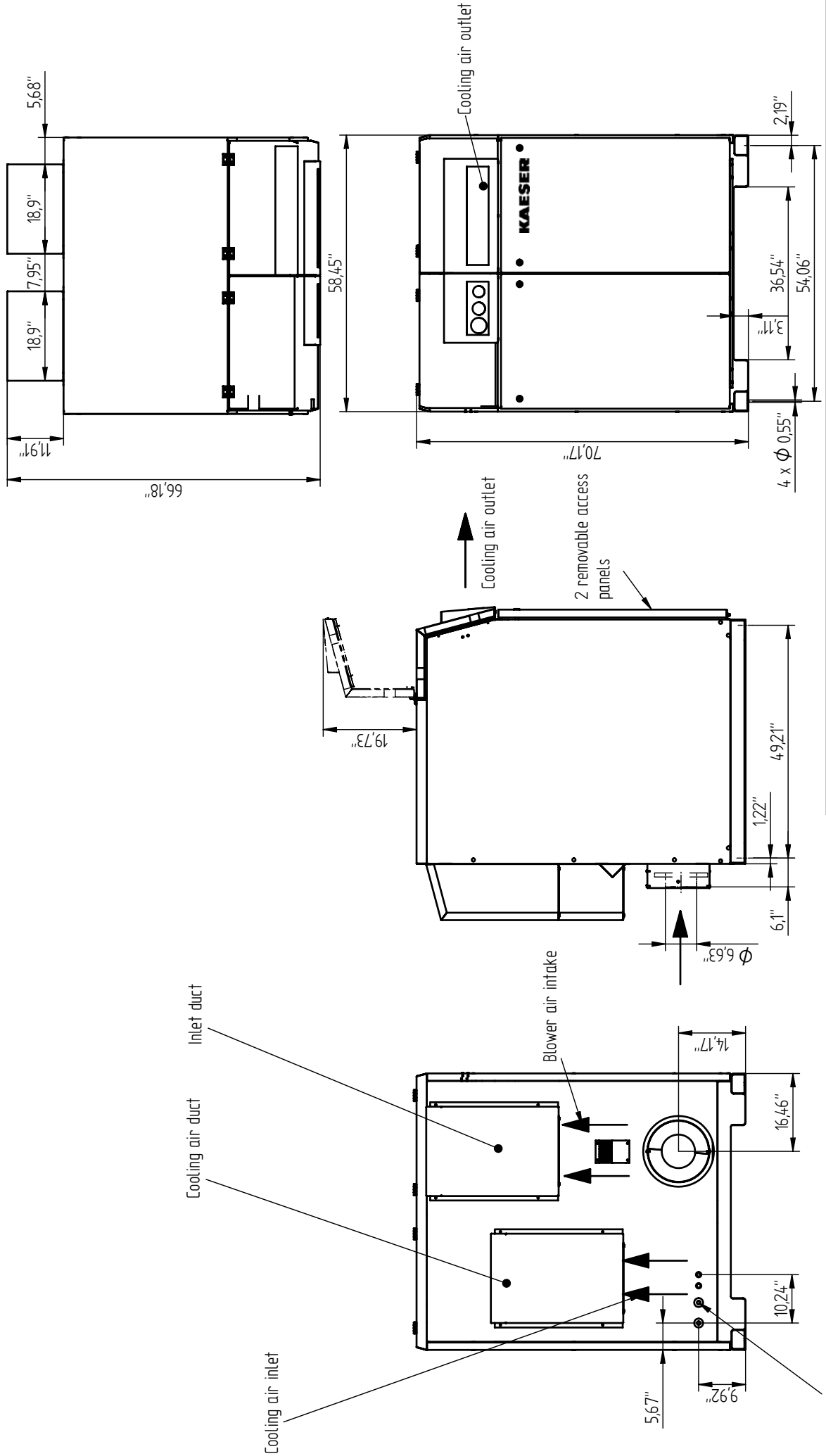

EB 290/420 C pr

Stand:	Datum:	Name:	CAD-Datei:
25.06.02	21.02.02	Lummer	MB001604.dft

1.10 Design Data (Diagrams)

Air delivery in pressure operation

Blower shaft power in pressure operation

Temperature increase in pressure operation

pressure performance
inlet: air at 14.7 psia and 68 °F

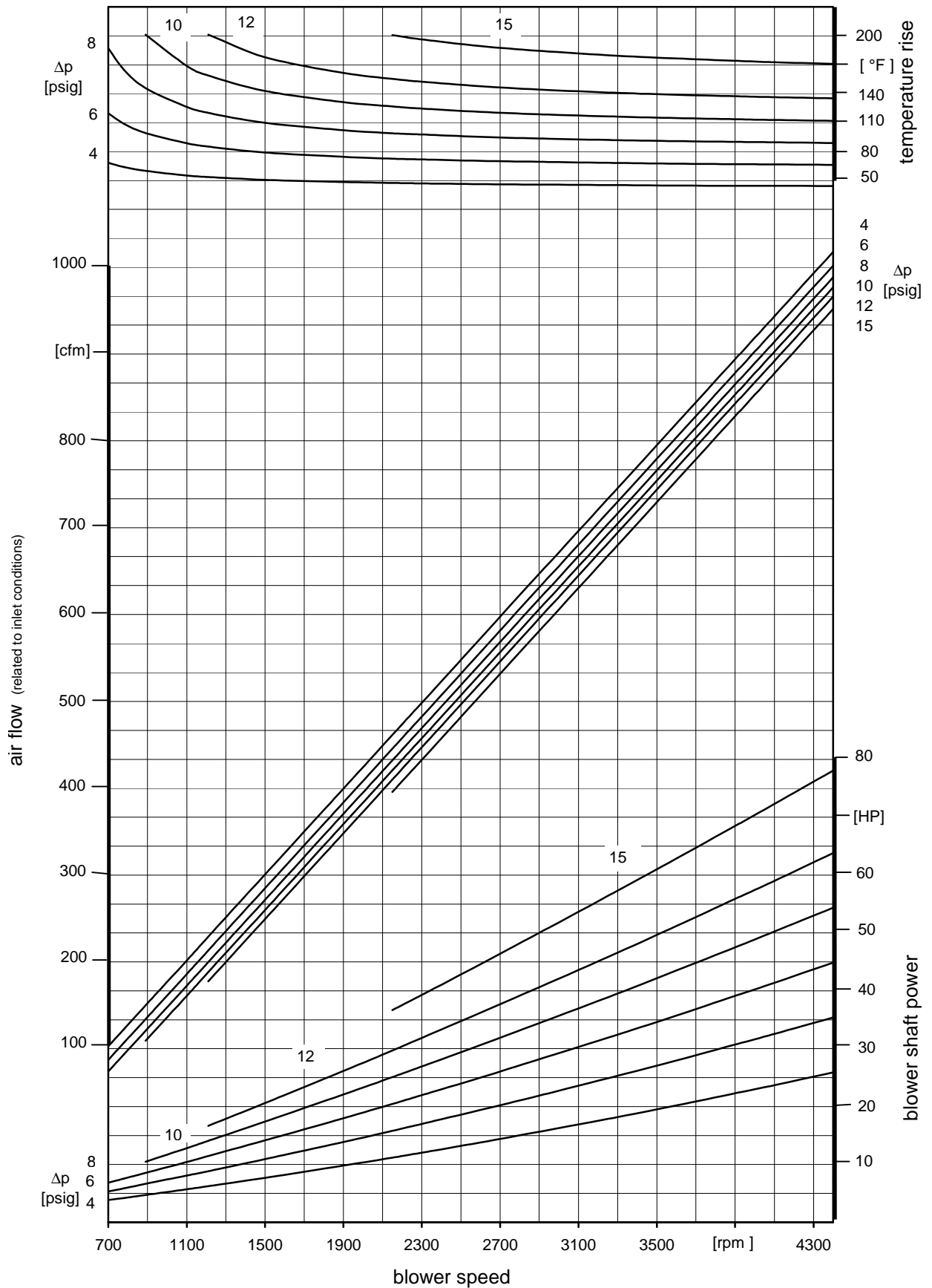

2 Safety Regulations

Read this Service Manual carefully and observe all cautionary references before putting the rotary blower package into operation and before carrying out any maintenance.

2.1 Explanation of Symbols and References



This symbol is placed before all references to safety where danger to life and limb can occur during work. It is especially important that these instructions are observed and that extreme care is taken. For their own protection inform all other users of these safety regulations. Observe general safety and accident prevention regulations as well as the safety instructions laid down in this manual.

Attention!

This symbol is placed at points where considerable attention should be paid to recommendations, instructions, references and correct sequences so that damage or destruction of the blower package and/or other equipment is prevented.



This symbol identifies environmental protection measures.



This symbol indicates operations to be carried out by the service technician or the operator.



This bullet indicates listings.

Explanation of the filter maintenance pictogram:

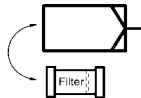

Note on the location of the inlet filter and the carrying out of filter maintenance.

Explanation of the warning notice on the rotary blower:



Warning:
Hot surface, do not touch.

Abbreviations:

VBG Association of Employers Liability Insurers (AELI)

UVV Accident Prevention Regulations (APR)

2.2 General Notes on Accident Prevention Regulations

The terms "UVV" and "VBG" are abbreviations and refer to specific accident prevention regulations of the Federal Republic of Germany.

Should any one of the regulations referred to in this service manual not conform to local accident prevention legislation then the stricter regulation applies.

Users of blower packages outside the Federal Republic of Germany are therefore obligated to check the valid accident prevention legislation concerning the blower package in the country of use. If legislation is precedent to German legislation, corresponding measures must be taken before the package is put into operation.

2.3 Accident Prevention Regulations

Accident prevention regulation 10.0 "Power Driven Work Units" (VBG 5)

Attention!

According to Accident Prevention Regulation VBG 5, Par. 12, the user of a rotary blower package is obligated to carry out the following measures (DIN VDE 0113 Part 1 and European Standards ES 60204-1 serve as appropriate instructions):

Rotary Blower Packages fitted with a drive motor of power exceeding 2.68 h.p. and drawing currents of more than 16 amps must be fitted with a lockable isolating switch (DIN VDE 0660, DIN VDE 0100) and fuses in the power supply to the blower package.

Details concerning the size of the isolating switch and the fuses are given in chapter 1.3.

Accident prevention regulation 13.4 "Compressors" (VBG 16)

Attention!

We refer especially to paragraph 12: General Installation and Condition of the Installation Space.

Accident prevention regulation 1.2 "Noise" (VBG 121)

Attention!

We refer especially to paragraph 10: Noise Protection for Personnel.

We also recommend observation of the following recommendations:

- No open flames and flying sparks at the place of installation.
- Ensure that sparks or high temperatures cannot cause fire or explosion during any necessary welding work on the package.
- Operating personnel must be instructed on the necessity of wearing ear muffs during operation of the package, especially during operation without the sound enclosure.
- Personnel should not linger for long periods in the direct vicinity of packages with damaging sound levels.
- Rotary blower packages may not be used for explosive, toxic, corrosive or damaging gases.
- Because of the high temperatures (up to 302 °F) do not touch the air pipes during blower package operation. Wait until the blower has cooled down and pressure has vented before attempting any repairs to the pipework.
- Use only the lubricants recommended by the manufacturer.

2.4 General References



Only trained or specialised personnel may work on power driven systems (see UVV 10.0).

Before work is carried out on electrical systems, carry out the following precautions in the sequence shown:

1. Switch off all phases
2. Ensure that the blower package is isolated and locked out
3. Check that no voltages are present

Vent or shut off the pipework if not otherwise stated in the service manual.

Attention!

The warranty is invalidated if any modifications are carried out without previous consultation and the consent of KAESER COMPRESSORS.

2.5 Spare Parts

Safe and reliable operation of the package is only guaranteed with the use of KAESER original spare parts.

3 General

Attention!

This Service Manual must always be available at the place of installation of package.

3.1 Correct Use

The package is intended solely for the transport of oil-free air under pressure and in conformity with the technical specification (see chapter 1.1).

Any other use is considered incorrect. The manufacturer cannot accept liability for any damage caused by incorrect use. The user alone is liable for any risks incurred. Correct use also means compliance with installation, removal, commissioning, operational and maintenance instructions laid down by the manufacturer.

3.2 Copyright

The copyright of this service manual is the property of KAESER Kompressoren GmbH: This service manual is intended for operating, maintenance and supervisory personnel use only. It contains instructions and technical diagrams that may not be copied, either completely or partly, distributed or evaluated by unauthorised persons for competitive purposes or divulged to any third party.

Transport

4 Transport

4.1 Transport Instructions

Attention!

To avoid damage to components of the package, we recommend the use of a fork lift truck, lift truck or a sling for transport.

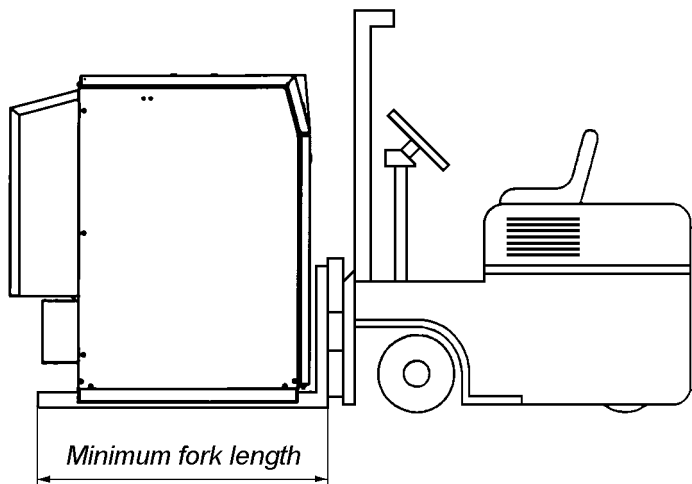

with sound enclosure

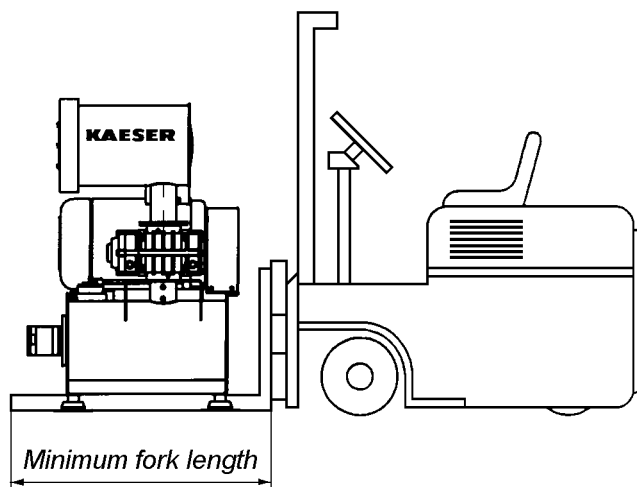

without sound enclosure

Attention!

When transporting using a crane hook, a suitable sisal or steel sling must be used (VBG 9a).

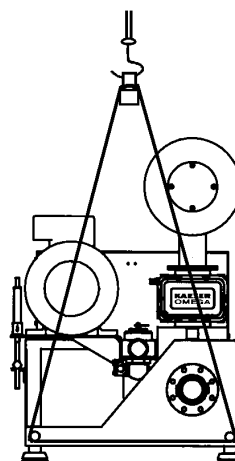
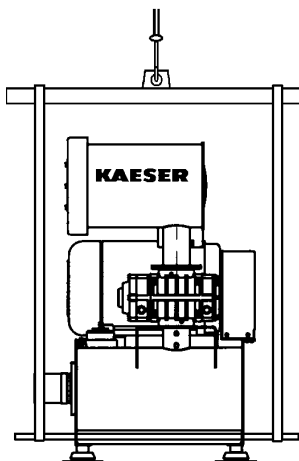
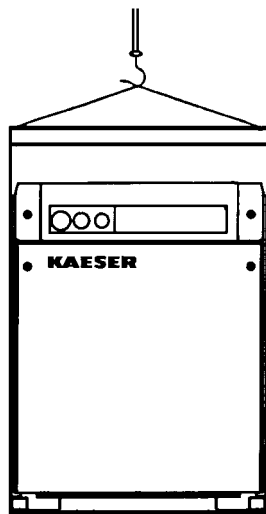

No side forces should act upon the package when transporting with a sling. Always use a spreader !

☞ To hang the rotary blower package, the sling bands must be fixed to the frame with a round bar of and padded, if necessary.

Avoid sudden, sharp vertical movements when lifting, lowering and transporting the rotary blower package.

4.2 Packaging

A decisive factor concerning the type of packaging is the transport route.

The packaging conforms to the packaging regulations laid down by the German Federal Association of Wood, Pallet and Export Packaging (HPE) and by the Association of German Mechanical Engineering Institutes (VDMA), if not otherwise contractually agreed.



Packaging should be recycled if possible or disposed of in an environmentally acceptable way.

4.3 Temporary Storage

Attention!

The package must be stored in a dry room at a constant temperature over 0°. Air inlet and air outlet openings should be closed off to prevent ingress of dirt.

When storage is to be longer than a year the block should be treated with a preserving oil.

- ☞ Spray preserving oil onto the flanged ports, drive shaft and air chamber to protect against corrosion.
- ☞ Carry out an oil change annually (see chapter 9.6).

Recommended preserving oil:

External:

ESSO RUST BAN 324
MOBIL OIL TECREX 39
SHELL V-Product 9703

Internal:

AVIA Avilub MK 2000
ESSO LUB MZ 20 W/20
MOBIL Mobilarma 523 or 524
SHELL Ensis Motor Oil 20

or similar makes.

Putting into operation after a long period of temporary storage:

- ☞ Remove the preserving material from the air chamber with a suitable solvent.
- ☞ Carry out the measures detailed for installation and putting into operation.
- ☞ Carry out an oil change (see chapter 9.6).

5 Construction and Principles

5.1 Compression

The package is fitted with a KAESER blower block with OMEGA profiled rotors. Two rotors, synchronised by a pair of timing gears, rotate in opposite directions in two cylindrical bores within a casing. A defined quantity of air entering the inlet port is trapped between the lobes of the rotors and the casing and carried round to the discharge port. Because there is no contact between the rotors and the housing there is no wear and no lubrication is required.

KAESER rotary blowers consume only as much power as is demanded by the back pressure existing at the discharge port.

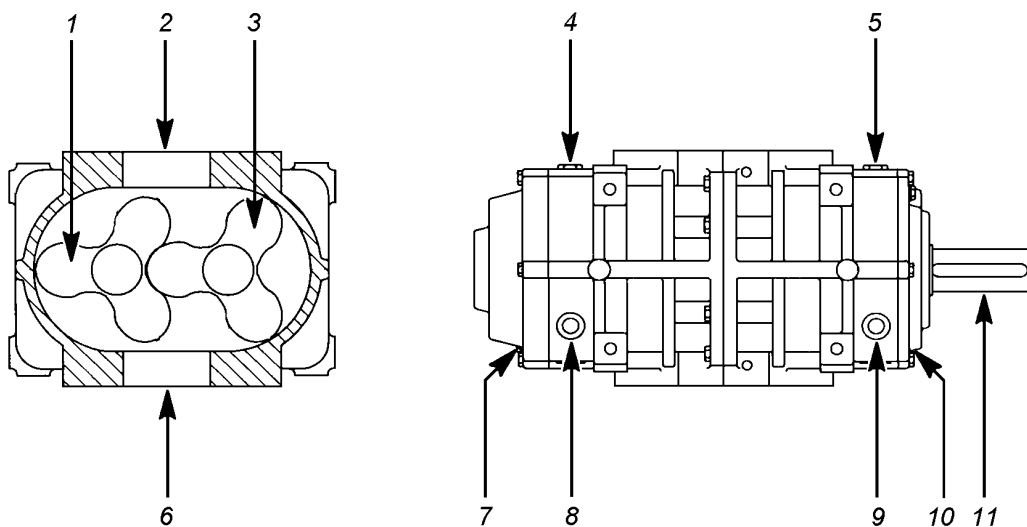

- 1 Male rotor
- 2 Inlet port
- 3 Female rotor
- 4 Oil filler plug, gear end
- 5 Oil filler plug, drive end
- 6 Discharge port

- 7 Oil drain, gear end
- 8 Oil level sight glass, gear end
- 9 Oil level sight glass, drive end
- 10 Oil drain, drive end
- 11 Drive shaft

5.2 Short Description

The rotary blower block is belt driven from an electric motor.

The electric motor and the blower are mounted on a common base frame.

The flow medium is drawn into the block via an inlet silencer in which an inlet filter is integrated.

The air flows in a vertical direction in the discharge silencer.

The compressed air is discharged at the connecting flange of the discharge silencer.

Ambient air inlet

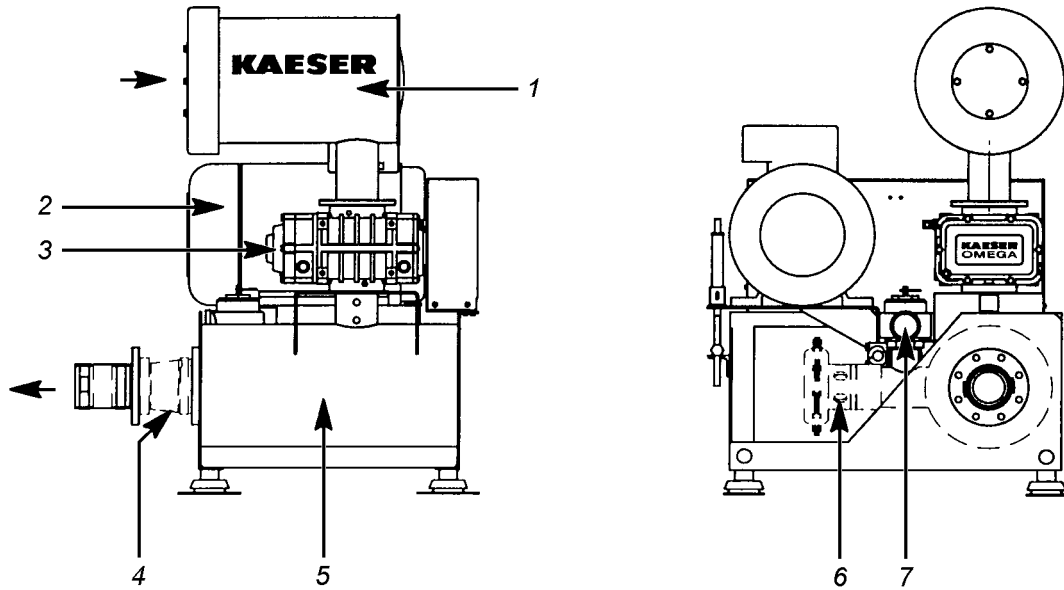

- 1 Inlet filter
- 2 Motor
- 3 Blower
- 4 Check plate (Option)

- 5 Discharge silencer
- 6 Unloaded-start valve (Option)
- 7 Safety valve

Piped inlet

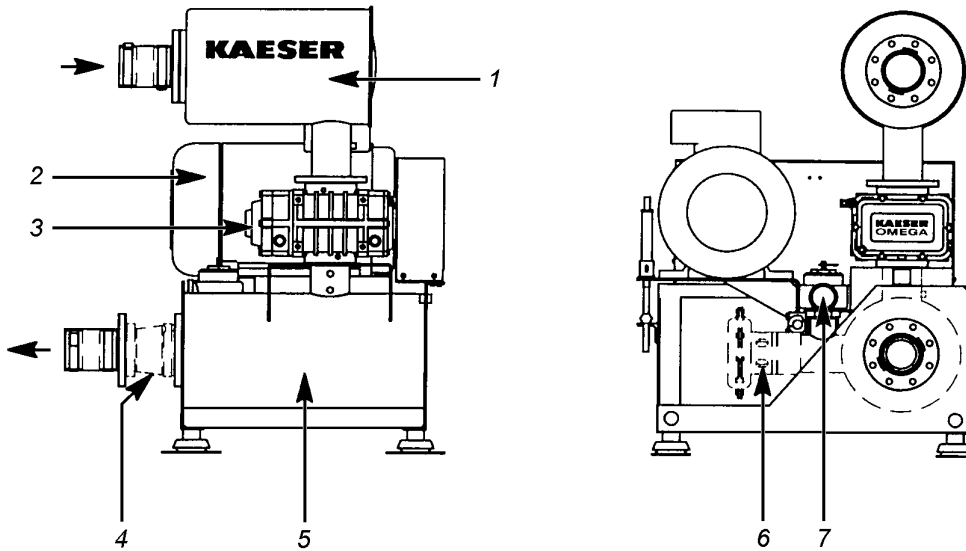

- 1 Inlet filter
- 2 Motor
- 3 Blower
- 4 Check plate (Option)

- 5 Discharge silencer
- 6 Unloaded-start valve (Option)
- 7 Safety valve

Installation

6 Installation

6.1 Installation Requirements

The package must be installed in a space of sufficient size allowing free access from all sides for maintenance and repair.

Sufficient air ventilation and exhaust conditions must be provided.

A special foundation or base is not required for installation.

Safe and reliable operation of the package is guaranteed only when the temperature limits laid down in chapter 1.8 are complied with.

6.2 Compressed Air Connection

The blower package is delivered ready for operation up to and including the compressed air discharge connection.

The discharge connection downstream to the pipework or user should be made via a flexible connecting sleeve, preferably a rubber sleeve.

Attention!

During installation of the package the regulations laid down in UVV 13.4 must be observed.

It is especially important that necessary safety devices, a check plate and operational measuring and control devices are provided.

If the air flows into a system which remains pressurised after switching off the blower package, an off-load starting valve or similar device must be fitted.

To ensure safe and reliable operation of the blower package it is recommended that at least the following parameters are monitored and interlocked with the drive:

- Discharge pressure or pressure difference Δp
- Discharge temperature
- Electrical current drawn

6.3 Electrical Connection



The main power supply connection and installed protective measures must be carried out by an authorised specialist according to DIN VDE regulations and the regulations of the electrical supply authority concerned.

Attention!

According to Accident Prevention Regulation VBG 5, Par. 12, the user of a rotary blower package is obligated to carry out the following precautionary measures (DIN VDE 0113 Part 1 and European Standards ES 60204-1 serve as appropriate instructions):

Rotary Blower Packages fitted with a drive motor of power exceeding 2.68 h.p. and drawing currents of more than 16 Amps must be fitted with a lockable isolating switch (DIN VDE 0660, DIN VDE 0100) and fuses in the power supply to the blower package.

Attention!

The size of the main isolating switch (to AC 23, category of use) is dependent on the maximum rated current I_N (see chapter 1.3).

Recommendations for the size of the cable core cross-sections and the fuses are detailed in chapter 1.3.

The cross-sections of the supply cable and the fuses are installed to DIN VDE 0100, Part 430 and 523 for an ambient temperature of 86 °F. Under other operational conditions, e.g. higher ambient temperatures or longer power supply cables (over 197") the supply cable cross-sections and fuses must be checked according to DIN VDE regulations and the regulations of the electrical supply authority concerned.

7 Putting into Operation

7.1 Points to be Observed

Every rotary blower package is given a test run in the factory and carefully checked before shipment. The test run confirms that the package conforms to the specification data and runs perfectly. However, it is recommended that it is inspected for damage that could have occurred during transport. The package should be carefully observed during the first hours of operation to determine any malfunction that could occur.

The user is responsible for the installation of the complete package.

- Before putting into operation check the correct sequence of the compulsory safety and monitoring devices and the necessary operational measuring and control devices for the processing technology used.
- Check the installation of check plate, valves and controls for correct direction.
- Remove the blanking caps fitted during installation.

7.2 Starting Precautions



ANY NON-OBSERVANCE OF THESE OR OTHER PRECAUTIONARY REFERENCES (WARNING, ATTENTION) COULD LEAD TO AN ACCIDENT CAUSING INJURY TO PERSONNEL OR DAMAGE TO EQUIPMENT.

- ☞ Remove all packaging materials, tools and transport safety devices.
- It is expected that the user employs safe working methods and complies with all valid local operating and safety regulations when operating the package.
- It is the responsibility of the user to ensure that the package is constantly kept in a state of operational safety.
- Do not operate the package in spaces in which high dust pollution, toxic or inflammable vapours and gases can form.
- Do not connect the package to a different power supply than that stated on the motor nameplate.
- Install the package in a frost-free space and where the ambient temperature conditions (see chapter 1.8) are met.
- ☞ Check the drive shaft for ease of rotation by turning with the hand.
- ☞ Check the tension of the belt drive (see chapter 9.3).
- ☞ Check the oil level and top up if necessary (see chapter 9.5).



Remove all electrical power from the blower package before carrying out this work.

Lock out the supplies to the blower package to prevent accidental switch-on.

7.3 Direction of Rotation Check



Danger from rotating parts

- The rotors **must** rotate in the correct direction.
- The correct direction of rotation is counter-clockwise when looking at the end of the shaft. An arrow indicating the direction of rotation is located on the belt guard and on the blower block.
- ☞ Remove the inlet filter inspection cover (also if the filter is integrated in the inlet silencer) or remove the check plate (non-return valve) complete. Open all shut-off devices.
- ☞ Check the direction by turning the control switch to "I" and then immediately back to "O" again and observing the direction of rotation.
- ☞ If the direction is incorrect, the phase sequence in the power supply must be changed.

Attention!

The rotation check must be made every time the machine or motor is disconnected and re-connected to the mains supply.

If the blower block rotates in the wrong direction a reversal of the direction of flow and an evacuation of the discharge pipework occurs.

Always check the direction of rotation with the discharge line disconnected because the blower block could be damaged or destroyed should if foreign bodies are sucked in or a high vacuum is generated.

8 Operation

8.1 Starting and Stopping the Blower Package



Observe the safety regulations when putting the package into operation.

The starting and stopping procedure depends largely on the application at hand together with the control devices fitted.

Always start with the blower stationary. If back pressure is apparent in the pipework system then suitable measures ensuring off-load starting must be taken.

If the blower package is operated via a two-speed motor the changeover from high to low speed must be delayed, i.e. the speed must have reduced to the lower speed or the blower must have stopped rotating before the motor is started again at the lower speed.

The motor can be switched directly to the higher speed.

Do not exceed the speed limits when operating the blower package with a frequency converter! At low rotational speeds and high pressure differentials the maximum permissible temperature could be exceeded. (see chapter 1.10).

Attention!

Do not switch the package on and off with the mains isolating switch. Always use the control switch.

8.2 Action to be taken during a Fault



The general safety regulations (see chapter 2) and the corresponding local safety regulations must be observed during fault-finding.

Re-starting after rectification of a fault:

See chapter 7 "Putting into Operation"

Explanation of the symbols used in the following fault diagnosis:

- ⊗1 - Have checked by a specialist.
- ⊗2 - Refer to KAESER customer service.

8.2.1 Abnormal running noises

Possible fault:

Backlash of the gears too large.

Bearing clearance is too large.

Rotors out of time.

Rectification:

Check the backlash. If it is > 0.004" replace the timing gears; ⊗1 or ⊗2.

Measure the clearance. Replace the bearing if necessary; ⊗1 or ⊗2.

Compare the conditions under use concerning pressure difference and speed with the conditions at delivery. Check the rotor chamber for contamination and clean if necessary.

8.2.2 Excessive blower temperature

Possible fault:

Operation with excessive pressure difference.

Contamination of the inlet filter causing degradation of volumetric efficiency.

Rotor clearance too large.

Rectification:

Check the pressure difference and correct if necessary.

Clean inlet filter.

Measure the clearance between the rotors and check with the manufacturer. Rotor replacement could be necessary, ⊗1 or ⊗2.

8.2.3 Oil leaking into the air chamber

Possible fault:

Oil level too high.

Rectification:

Drain the oil until the level is in the middle of the oil level sight glass. Clean out the air chamber with cleanser.

8.2.4 Low inlet volume flow

Possible fault:

Excessive rotor clearance caused by wear, especially by heavily contaminated flow medium.

Inlet flow resistance too high.

Rectification:

Measure the clearance between the rotors and check with the manufacturer. Rotor replacement could be necessary; ⊗1 or ⊗2.

Clean the inlet filter.

9 Maintenance

9.1 Precautions to be Observed during all Maintenance and Servicing



Work on power driven equipment may only be carried out by trained or specialised personnel, see UVV 10.0 (VBG 5).

Before carrying out any maintenance, switch off and lock out the mains isolating switch.

Ensure that no personnel are working on the package before restoring power.



Care must be taken to see that operating materials and used parts are disposed of in a manner conducive to environmental protection.

9.2 Regular Maintenance

Service interval	Work to be done	See chapter
24 hours after first putting into operation	Check drive belts tension and adjust if necessary	9.3
50 hours after first putting into operation	Check all electrical connections for tightness and tighten, if necessary	
500 hours after first putting into operation	Change the lubricating oil	9.6
500 hours or monthly	Check lubricating oil level	9.6
	Check drive belts tension and adjust if necessary	9.3
On series BB: 4000 hours or annually On series DB, EB, FB, HB: 6000 hours or annually	Change the lubricating oil *	9.6
Annually	Check all electrical connections for tightness and tighten if necessary	
	Check pressure relief valve	
	Check condition of drive belts	
10 000 hours or after 4 years.	Grease motor bearings or replace	9.9
12 000 hours or after 2 years	Change drive belts	9.4
See motor nameplate	Grease motor bearings	9.9

* The maintenance period can vary depending on the cut-in frequency and environmental conditions.

We urgently recommend that a record is kept of maintenance work done (see chapter 11.2)

9.3 Checking Drive Belt Tension

☞ Switch off the package (see chapter 8.1)



Switch off and lock out the mains isolating switch to prevent accidental or unauthorised switch-on.

Check the tension of the drive belts after the first 24 hours and then every 500 hours of operation.

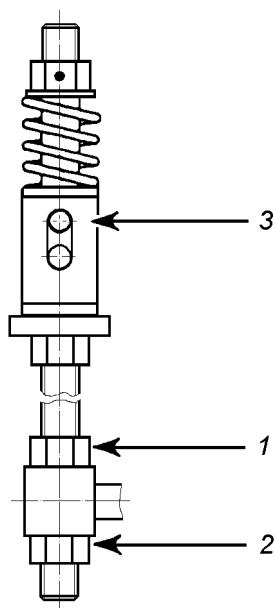

1 & 2 *Adjusting nuts*
3 *Indicator pin*

The tensioning device automatically adjusts the belt tension over a certain range with the aid of a compression spring.

If the drive belts have stretched to the extent that the indicator pin (3) is located at the top end of its slot, the belt tension must be re-adjusted.

Proceed as follows:

- ☞ Loosen nut (1).
- ☞ Tighten the belts with nut (2) until the indicator pin (3) is located at the lower end of the slot.
- ☞ Tighten nut (1) again.

9.4 Changing the Drive Belts

☞ Switch off the package (see chapter 8.1)



Switch off and lock out the mains isolating switch to prevent accidental or unauthorised switch-on.

- ☞ Release nut (2, see chapter 9.3) of the tensioning device.
- ☞ Turn the hexagon nut (1, in section 9.3) so that it moves downwards until belt tension is released.
- ☞ Remove the belts.
- ☞ Lay the new belts over the motor and block pulleys without straining them.
- ☞ Reset the belt tension (see chapter 9.3).
- ☞ Refit the belt guard.
- ☞ Check belt tension after two hours and then again after 24 hours of operation as experience shows that the belts stretch mostly during this period.

Attention!

V-belts must be of exactly the same length and so should be changed as a set, not individually. The use of KAESER original parts is highly recommended.

9.5 Lubricating Oil Level Check and Top-Up

Check the lubricating oil level monthly at the gear end and drive end with the package switched off. The oil level should never fall below the middle of the oil level sight glass. The oil level at the sight glass changes during operation because of the rotating parts. For this reason the check the oil level only when the package is stationary.

Attention!

If the oil level has fallen to 0.12" below the middle of the oil level sight glass, the blower must be topped up according to the instructions in the oil recommendations.

Never top up above the middle of the oil level sight glass otherwise oil could be forced into the air chamber.

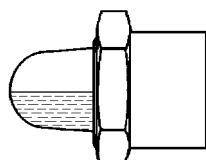

Lubricating oil level at middle of oil level sight glass

- ☞ Top up with lubricating oil via "red" oil filter plugs on the gear and drive ends of the block until the middle of the oil level sight glass is reached (see chapter 1.5).
- ☞ Top up only with oil of the same sort that is already in the machine (see label on the block)

Attention!

The oil chambers of the gear and drive ends are not connected to each other.

9.6 Lubricating Oil Change

Attention!

Carry out the first lubricating oil change after the first 500 hours of service. Carry out the oil change with the blower block at operational temperature.

See chapter 9.2. for further lubricating oil change intervals.

- ☞ Prepare an oil catchment container

- ☞ Remove the oil filler plugs to facilitate drainage (see chapter 5.1).
- ☞ Remove the caps (1 and 2) and open the drain taps (3 and 4) and drain the oil.

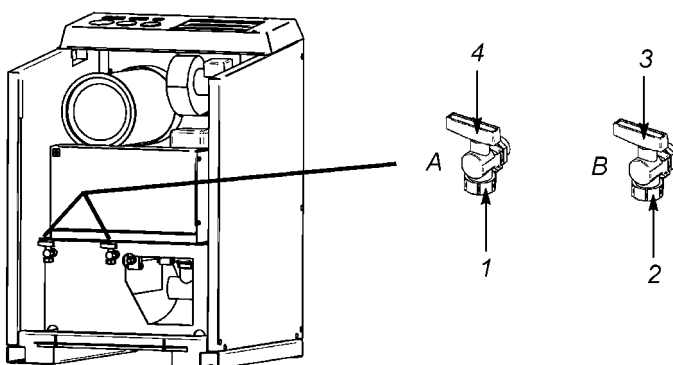

- 1 Cap
- 2 Cap
- 3 Oil drain tap
- 4 Oil drain tap

- A Drive-end
- B Gear-end



Collect the used oil in a suitable container and dispose of according to environmental regulations!

- ☞ Fill up with new lubricating oil to the middle of the oil level sight glass (see chapter 9.5). Use only the lubricating oil detailed in the oil recommendations (see chapter 1.6).
- ☞ Allow the drain taps to remain open until oil flow out (drain line vented).
- ☞ Check the oil level and top up as necessary.
- ☞ Close the drain taps and replace the caps.
- ☞ Replace the filler plugs.
- ☞ Check for leaks.

9.7 Cleaning the Blower Package

- ☞ Regularly clean the surfaces of the blower and drive motor and keep free of dirt and contamination.

Attention!

Layers of dirt inhibit heat dissipation and damage may occur through overheating.

9.8 Air filter changing

The air filter should be changed every 2500 operating hours or when indicated by the filter monitor.



Switch off and lock out the mains isolating switch to prevent accidental or unauthorised switch-on.

- ☞ Remove the inlet silencer cover
- ☞ Remove the Velcro securing band and take out the old air filter
- ☞ Place the new filter on the perforated inlet port and secure with Velcro band
- ☞ Replace and secure the inlet silencer cover.

9.9 Greasing the Electric Motor

The maximum maintenance-free period of permanently greased motors is at least 10 000 service hours but 4 years maximum.

On motors with a greasing device the amount of grease and the period are shown on name-plate on the motor.

10 Spare Parts and After Sales Service

Nameplate:

		KAESER KOMPRESSOREN GMBH Carl-Kaeser-Str. 26, D-96450 Coburg Germany, Tel.: (0 95 61) 640-0 Fax.: (0 95 61) 640-130	
		Model	Flow capacity m³/min
Serial No.	Inlet pressure kPa (abs.)	Part No.	Outlet pressure kPa (abs.)
Year	Max. pressure diff. kPa	Motor power kW	Blower speed min⁻¹

Important: Enter data from the package nameplate in the diagram above.

Please quote the following information for all queries and orders for spare parts:

1. Rotary blower package, Model:
2. Part No:
3. Serial No:
4. Description of the part:
5. Order number of the part:

Attention!

Use only KAESER original spare parts.

11 Appendix

11.1 Instructions on Electrical Connection

(see following page)

Connection diagram for motor (exact level / single speed)

Output 2,2kW / 3hp ... 30kW / 40hp

230V/60Hz (6 leads) = Y/ Δ -start or direct (d.o.l.) in Δ -connection
460V/60Hz (6 leads) = only direct (d.o.l.) in Y-connection

Output >= 37kW / 50hp

460V/60Hz (6 leads) = Y/ Δ -start or direct (d.o.l.) in Δ -connection

Star connection

Connecting together the W2, U2, V2 terminals (star point) and connecting to the mains the U1, V1, W1 terminals a star connection is obtained.

The phase current I_{ph} and the phase voltage U_{ph} are the following:

$$I_{ph} = I_n$$

$$U_{ph} = U_n / \sqrt{3}$$

where I_n the line current and U_n is the line voltage.

Delta connection

Connecting the end of each winding to the beginning of the next winding a delta connection is obtained.

The phase current I_{ph} and the phase voltage U_{ph} are the following:

$$I_{ph} = I_n / \sqrt{3}$$

$$U_{ph} = U_n$$

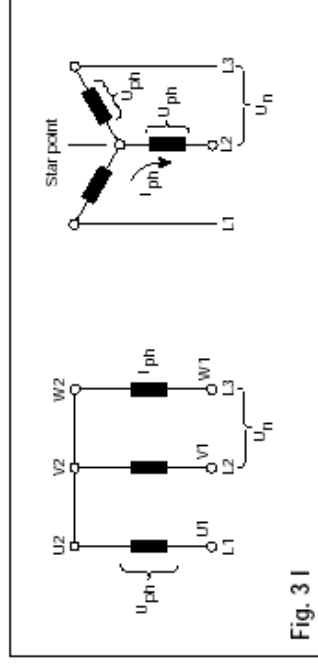

Fig. 3 I

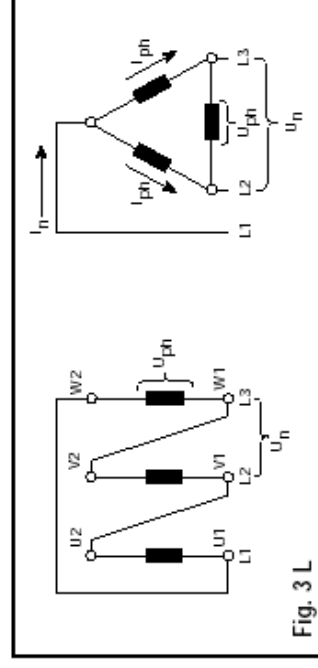
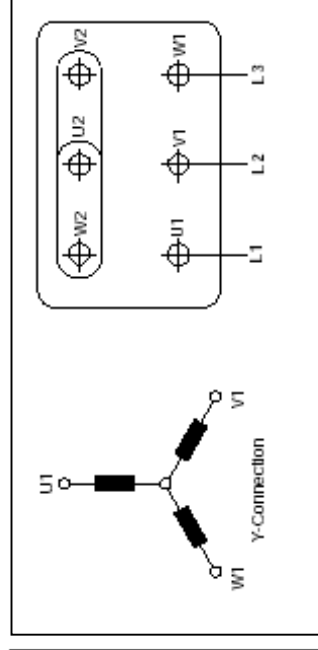
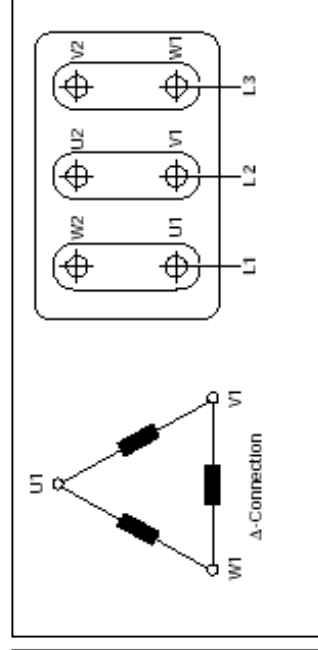

Fig. 3 L



Star-Delta starting:

The star-delta starting is an easy way to reduce the starting current and starting torque.

Motors can be started with star-delta starting method whenever the supply voltage correspond to the rated voltage of the motors in delta connections. Please connect the 3 thermistors (3x PTC) on lead T1 and T2 in the terminal box of the motor. (Attention: No voltage higher than 2,5V on T1 and T2 !)

11.3 Safety information concerning contamination of compressors, blowers, vacuum pumps and components

Application and purpose

Every company is responsible for the health and safety of its employees. This extends to personnel who carry out servicing work at the company's premises or at the site of the user.

The attached declaration is intended to inform the service contractor of any possible contamination to be found in compressors, blowers, vacuum pumps or components sent to him for servicing. Based on this information, the service contractor can instigate the necessary protective measures when carrying out the service work.

Preparation for shipment

Before shipping the item(s), the sender should fill out and sign the attached Declaration of Contamination form (one for each item) and attach a copy to the shipping documents and a copy on the outside of the packaging.

Please note the following shipping regulations:

- drain all operating fluids
- remove filter elements
- make all openings airtight
- pack correctly
- ship in suitable container
- fix a copy of the Declaration of Contamination to the **outside** of the packaging

Pressure relief valve

Part No.: 891515.01030

Issue: 06/04



Technical Specification

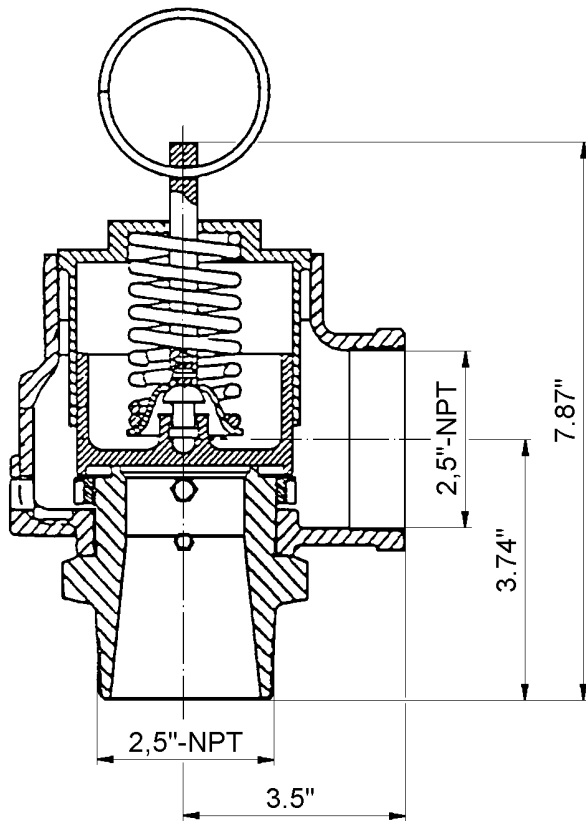

Pressure setting: 14.9 psig

Installation

Installation of the pressure relief valve is only possible in the standing position (see dimensional diagram)

Pressure pipe connection

General

The pressure relief valve serves to protect the rotary blower against excessive pressure. The medium is blown off into the open. The pressure relief valve must be positioned such that no danger can arise. When the pressure relief valve opens very high noise levels can occur.

Check the pressure relief valve at regular intervals for correct function by opening with the venting lever. The intervals should be set by the user but must be opened at least once annually.

Close the pressure relief valve immediately after the valve blows off.

If contamination causes the pressure relief valve to leak, the valve could be cleaned by blowing off several times.

Attention!

The pressure relief valve is set to the pressure quoted above and sealed. It is not permitted to change the pressure relief valve setting and any such change invalidates all liability whatever.

Pressure Gauge

Part No.: 884225.0

Issue: 1/96

Contents

- 1 Scope of Delivery/Spare Parts List
- 2 Installation Instructions
- 3 Diagram showing connection of Measuring Points on the Blower Package

1 Scope of Delivery/Spare Parts List

Item No.	No. off	Order No.	Description
1	1	890458.0	Male stud fitting $\frac{1}{4}$ taper
2	2	9.0675.0	Insert for Tecalan pipe
3	1	9.0616.0	Tecalan pipe, 78 $\frac{3}{4}$ " long
4	1	6.1704.0	Pressure gauge fitting
5	1	891485.1	Pressure gauge, 23.2 psi

2 Installation Instructions

Remove all power from the package before commencing work !

- 2.1 Remove the screw plug at measuring point "a" on the blower package.
- 2.2 Screw in the male stud fitting (item 1) and seal with liquid sealing material.
- 2.3 Push the Tecalan pipe insert (item 2) into one end of the Tecalan pipe (item 3) and fit into the fitting (item 1).
- 2.4 Fit the pressure gauge fitting (item 4) to the gauge (item 5).
Caution! lay in the sealing ring first.
- 2.5 If not already done, prepare the fitting point for the pressure gauge (item 5) by removing the cover and any foam that may be present.
- 2.6 After removing the clamp, push the pressure gauge (item 5) into the 2.52" hole provided and affix with the clamp.
- 2.7 Push the insert (item 2) into the free end of the Tecalan pipe (item 3) and connect the pipe to the pressure gauge fitting (item 4).

3 Diagram showing connection of Measuring Points on the Blower Package

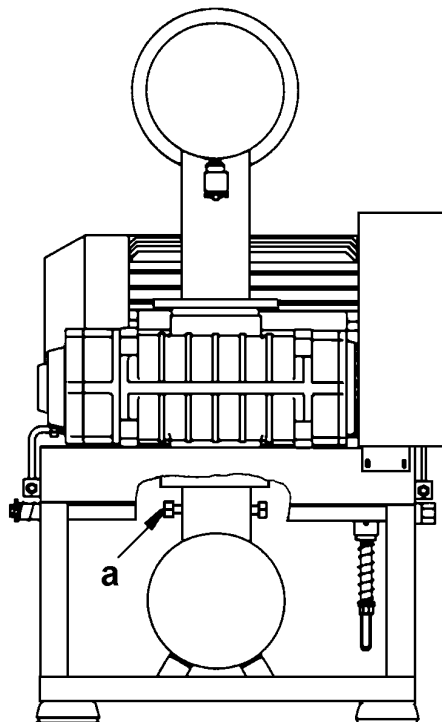

Temperature Gauge Switch



Part-No.: 891636.3

Issue: 01/05

Technical Specification

Display: 0 - 392 °F
Enclosure protection: front: IP 53
rear: IP 54 with extra code
Indication: linear, Class 2 to
DIN 16203
Measuring system: liquid-filled
Mounting position: any
Limiting temperatures: for transport and storage
- 4 to + 158 °F

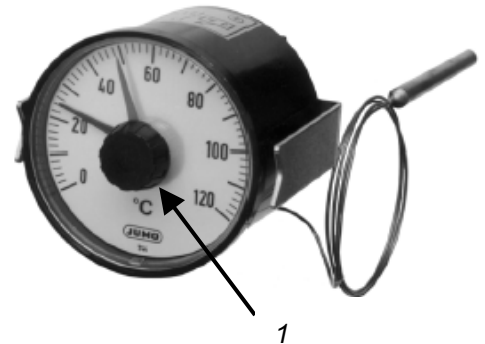

Electrical contacts:
- Contact rating AC 250 V, 5 (1,5) A, single-pole microswitch with changeover contact
- Switching differential < 3% of scale span
- Switching point accuracy ± 5 % of range span referred to switch-off point on rising temperature
- Connection: Faston connectors A 6,3 x 0,8 to DIN 46244
- Switching reliability: In order to ensure maximum switching reliability we recommend a minimum voltage of 24 V AC and a minimum current of 20 mA

Connection diagram
Switch output

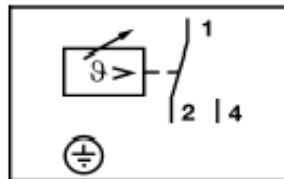

Dimensions

Width of fixing bracket

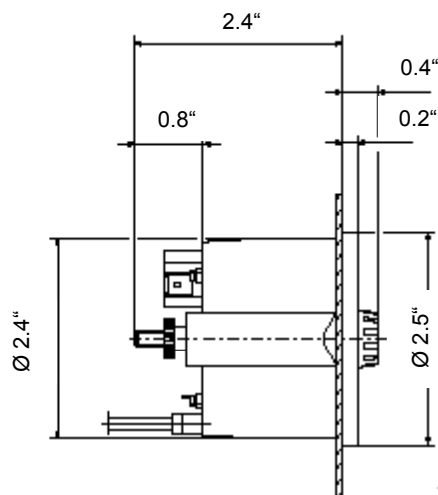
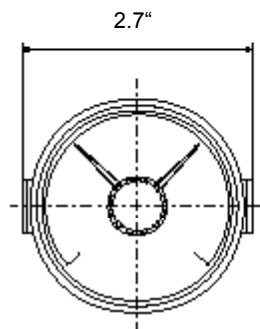

Setpoint adjustment

The switching point is set by a screw beneath the front plate (1) protective cover.

Maintenance Indicator

For front panel installation



Part No.: 885593.0

Issue: 12/97

- Contents:**
1. Scope of delivery/Spare parts list
 2. Fitting instructions
 3. Diagram of connection to blower package
 4. Function

1. Scope of delivery/Spare parts list

Item No.	No. off	Part No.	Description
1	1	6.0246.0	$\frac{1}{8}$ Male stud fitting tapered
2	2	9.0675.0	Insert for Tecalan pipe
3	1	9.0616.0	Tecalan pipe 79"
4	1	885594.0	Fitting for maintenance indicator
5	1	892224.0	Maintenance indicator

2. Fitting instructions

Attention! Carry out this work when the package is shut down only!

- 2.1 Remove the plug at test point "c" on the blower package
- 2.2 Screw in the male stud fitting (item 1) and seal with liquid sealing material
- 2.3 Push the insert (item 2) into one end of the Tecalan pipe (item 3) and fit into the male stud fitting (item 1)
- 2.4 Fit the fitting (item 4) to the maintenance indicator (item 5)
- 2.5 Prepare the connecting point of the maintenance indicator (item 5) to the blower package (if not already done) by removing the cover and any foam behind the cover
- 2.6 Pull off the snap ring from the maintenance indicator (item 5) and insert the ring from the front into the 2.16" diameter hole provided. Push the maintenance indicator into the snap ring from the rear
- 2.7 Push the second insert (item 2) into the free end of the Tecalan pipe (item 3) and connect the pipe to the fitting (item 4)

3. Diagram of connection to blower package

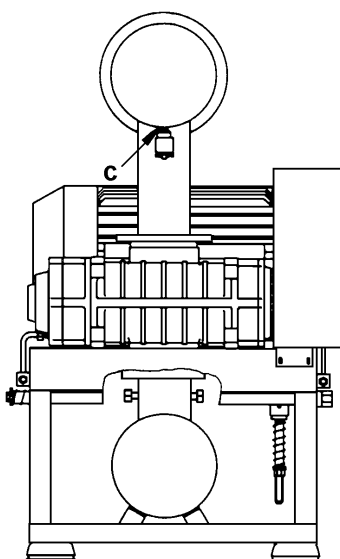

4. Function

If the maintenance indicator moves into the red area the air filter is clogged up and must be serviced. After servicing reset the indicator by pressing the knob.



Installation instructions

**Transportable
sound enclosure
for rotary blower packages**

**EB 290 C pr
EB 420 C pr**

Part no.: 882335.00310

Contents

- 1 Scope of Delivery
- 2 Technical Specification
- 3 Intended use
- 4 Design
- 5 Rotary Blower Package Maintenance
- 6 Assembly
- 7 Electrical Diagrams

1 Scope of Delivery

The sound enclosure is supplied already fitted to the blower.

2 Technical Specification

Dimensions: L x W x H 61.4" x 58.5" x 70.2"

Weight: ~ 750 lbs

Sound reduction: ~ 18 - 20 dB

Fan power supply: see 7

2.1 Dimensional drawing

(see following page)

Drawings remain our exclusive property. They are entrusted only for the agreed purpose. Copies or any other reproduction, including storage, treatment and dissemination by use of electronic systems must not be made for any other than the agreed purpose. Neither originals nor reproductions may be given to or made available to third parties.

Development changes may be made without notice. Drawings may only be changed via CAD.

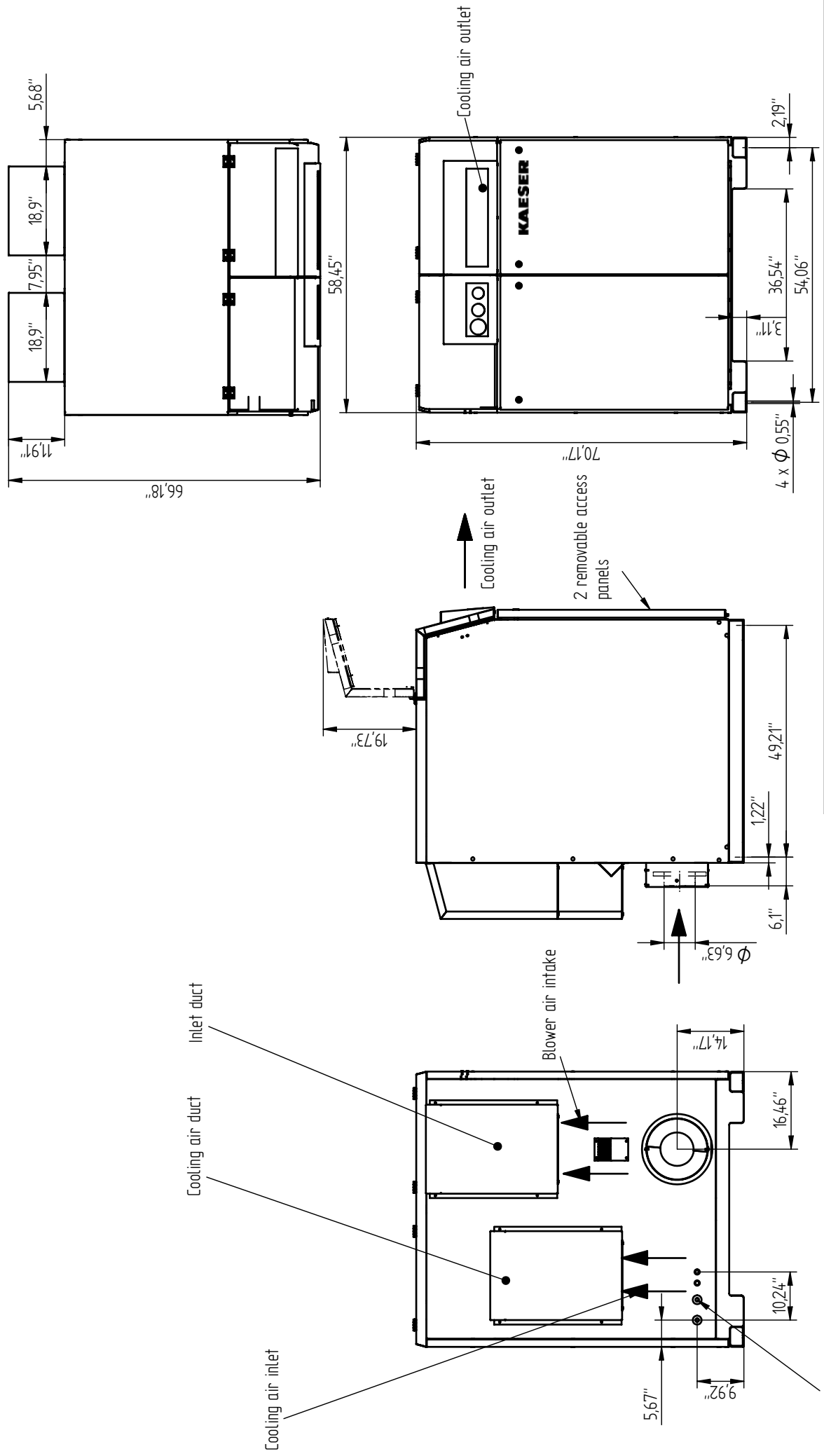

Cable leadthrough
 2x grommets Ø 1,41"
 2x grommets Ø 0,82"

EB 290/420 C pr

Stand:	Datum:	Name:	CAD-Datei:
25.06.02	21.02.02	Lummer	MB001604.dft

3 Intended use

The sound enclosure is intended to reduce the sound emission from a rotary blower package. When fitted, a compact unit is formed that can be transported by fork truck.

4 Design

The steel enclosure is mounted on an enclosed base frame. The enclosure consists of three side panels, two removable maintenance panels, a lift-up cover for maintenance access and a further lift-up cover to allow access only for electrical connection and repair work. All panels and covers are powder-coated and lined with 1.57" thick sound absorbing material.

4.1 Airflow

A fan on the motor draws air into the enclosure through the air inlet opening to provide cooling for the motor and as inlet air for the blower. A fan mounted in the discharge air deflector strengthens the airflow to improve cooling in the enclosure. Never block the apertures through improper installation or by objects. Process air is drawn in through a separate opening or duct and this air should be at ambient temperature. Reducing the size of the cooling air inlet and exhaust openings will lead to malfunctioning of the blower package and the sound enclosure.

5 Rotary Blower Package Maintenance

Access to filter element in the inlet air silencer is by lifting up the left side cover and removing the access panel. When the machine is opened in this way the belt tensioning can be optically checked and it can be adjusted if necessary. It is also possible to check the air filter condition indicator (if fitted) and to check the blower block oil level and change the oil when necessary. If an unloaded start valve is fitted it can be adjusted with the machine opened in this way.

Lifting up the right cover gives access to the main terminal box, the motor bearing greasing device and the discharge fan and its terminal box.

Attention!

Before beginning work, make sure the lift-up cover is secured in the upper position.

6 Assembly

The sound enclosure is supplied already fitted to the blower and when the combined package is placed in position, the following must be carried out:

- remove the two access panels
- unclip and lift the left cover, which is supported by a gas prop
- remove the three screws fixing the right cover, lift it up and

Attention!

Before beginning work, make sure the lift-up cover is secured in the upper position.

- connect the fan motor in accordance with local regulations and with reference to the electrical diagram. Ensure that there is no tension on the connecting cable, that it is of sufficient length and that fuses are connected.
- connect the pressure or vacuum pipelines
- attach the collar halves to the compensator hose at the end of the port and fix with counter-sunk screws.
- close the covers and replace the panels

- Apply sealant to the outside of the enclosure after installation. Check at least every 2 years and repair or replace as necessary.

Note!

A key is provided for assembling and dismantling the sound enclosure.

7 Electrical Diagrams

Fan CMP 616 2T (Part No. 893370.0)

3-phase fan motor

Voltage/frequency:	Delta (Δ): 266 V / 60 Hz Wye (Y): 460 V / 60 Hz
Power:	0.6 h.p. (60 Hz)
Current:	1.74 A (Δ) (60 Hz), 1.0 A (Y) (60 Hz)
Rated speed:	3340 rpm (60 Hz)
Enclosure protection:	IP55
Connection:	direct to the motor terminal box

Connection diagram

Wye
Y (460 V)

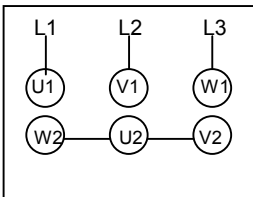

Delta
 Δ (266 V)

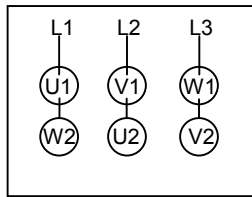

Max. delivery of fan: 842 cfm (60 Hz)

Connecting Instructions

- The fan motor should be so connected that it runs concurrent with the blower motor.
- Direction of airflow is out of the sound enclosure.
- Make sure that earth is connected. Make sure that cables connected in the terminal box are not under mechanical tension.
- If the fan stops while the rotary blower is in operation the temperature inside the enclosure can rise to an unacceptable level.
- In such a case, a supply of cooling air must be provided or the blower motor stopped to avoid damage.
- If the fan is arranged to continue running for about 15 minutes after the blower motor has stopped, this improves the thermal conditions in the sound enclosure.

Attention!

The connection to the power supply and protective measures taken must be carried out to the provisions of the local electricity supply authority by a qualified electrician.

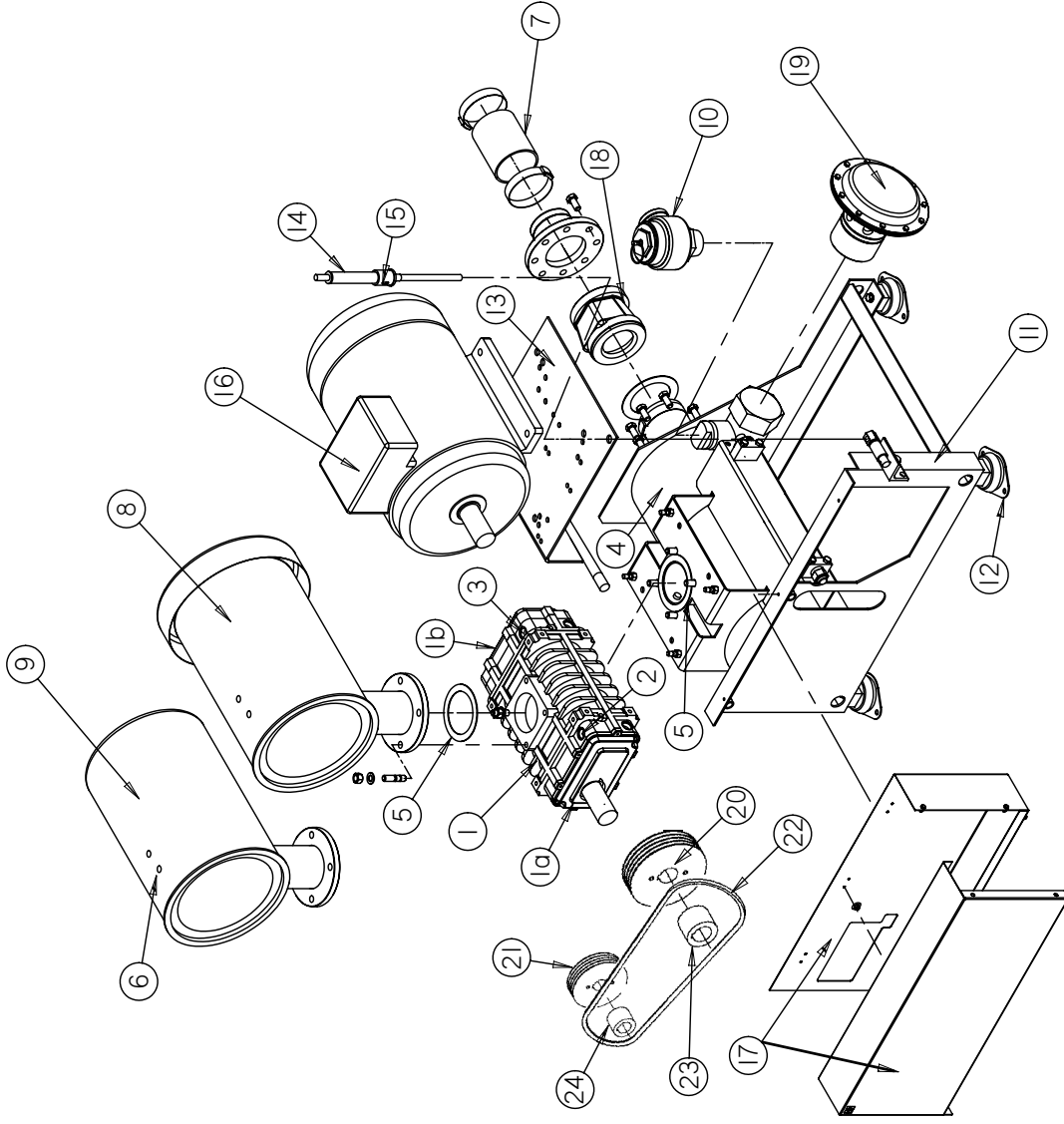

Main components

Item	Description
1	Blower block
1a	Drive-side
1b	Gear-side
2	Screw plug (drive-side oil filling)
3	Screw plug (gear-side oil filling)
4	Outlet silencer
5	Gasket
6	Connection - maintenance indicator G 1/8
7	Compensator
8	Inlet silencer (with filter)
9*	Inlet silencer (with pipe connection)
10	Pressure relief valve
11	Base frame
12	Machine mounting
13	Motor swing-frame
14	Motor swing-frame adjustment
15	Belt tension indicator
16	Drive motor
17	Belt guard (2-part)
18*	Check plate
19*	Unloaded start valve
20	V-belt pulley, motor
21	V-belt pulley, blower block
22	V-belt
23	Tensioning bush (motor)
24	Tensioning bush (block)

* optional, depending on application

Compact blower parts list

Stand:	Datum:	Name:	CAD-Datei:
24.02.99	19.05.04	Ploschmik	MB002027.dft