



KRD Series

Refrigerated Type Compressed Air Dryers
Models: 1000, 1300, 1500, 1750, 2000, 2500, 3000

INSTRUCTION MANUAL

Contents

GENERAL SAFETY INFORMATION	2	ELECTRICAL SCHEMATICS	10
RECEIVING, MOVING, UNPACKING	2	DIMENSIONS / WEIGHTS	12
1.0 INSTALLATION	3	ENGINEERING DATA	13
2.0 OPERATION	5	TROUBLESHOOTING	14
3.0 MAINTENANCE	8	PARTS LIST	15
SIZING	9	WARRANTY	16

GENERAL SAFETY INFORMATION

1. PRESSURIZED DEVICES:

This equipment is a pressure containing device.

- Do not exceed maximum operating pressure as shown on equipment serial number tag.
- Make sure equipment is depressurized before working on or disassembling it for service.

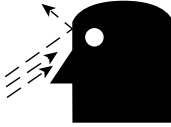

2. ELECTRICAL:

This equipment requires electricity to operate.

- Install equipment in compliance with all applicable electrical codes.
- Standard equipment is supplied with electrical enclosures not intended for installation in hazardous environments.
- Disconnect power supply to equipment when performing any electrical service work.

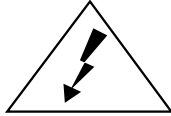

3. BREATHING AIR:

- Air treated by this equipment may not be suitable for breathing without further purification. Refer to applicable standards and specifications for the requirements for breathing quality air.

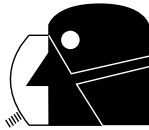

RECEIVING, MOVING, AND UNPACKING

A. RECEIVING

This shipment has been thoroughly checked, packed and inspected before leaving our plant. It was received in good condition by the carrier and was so acknowledged.

Check for Visible Loss or Damage. If this shipment shows evidence of loss or damage at time of delivery to you, insist that a notation of this loss or damage be made on the delivery receipt by the carrier's agent.

B. UNPACKING

Check for Concealed Loss or Damage. When a shipment has been delivered to you in apparent good order, but concealed damage is found upon unpacking, notify the carrier immediately and insist on his agent inspecting the shipment. Concealed damage claims are not our responsibility as our terms are F.O.B. point of shipment.

C. MOVING

In moving or transporting dryer, do not tip dryer onto its side.

D. STORAGE/SHUT DOWN

⚠ CAUTION Dryer should not be stored outside (either packed or unpacked) or exposed to the weather. Damage to electrical and control components may result.

IMPORTANT: WATER-COOLED UNITS - If unit is shut down below freezing temperatures, the water-cooled condenser may freeze and cause permanent damage. Condenser must be drained when the unit is shut down.

IMPORTANT: Do not store dryer in temperatures above 130°F, 54.4°C.

IMPORTANT: READ PRIOR TO STARTING THIS EQUIPMENT

1.0 INSTALLATION

1.1 Location

- A. For typical placement in a compressed air system, see drawing.
- B. Air compressor intake—Locate air compressor so that contaminants potentially harmful to the dryer (e.g. ammonia) are not drawn into the air system.
- C. Dryer should be installed in a moderately heated, well ventilated area. Avoid locations immediately adjacent to cold exterior windows or walls, or adjacent to high temperature ovens or boilers.
- D. Clearances: Free air flow

Models 1000 to 1500:

- Front 24 inches (610 mm)
- Back 36 inches (915 mm)
- Sides 24 inches (610 mm)
- Top 36 inches (915 mm)

Models 1750 to 3000

- Front 24 inches (610 mm)
- Back 36 inches (915 mm)
- Sides 24 inches (610 mm)
- Top 36 inches (915 mm)

Service - To facilitate maintenance leave 24 inches (610 mm) of clearance in front of dryer.

- E. Standard units are designed to operate in ambients:
Air-cooled: 45 to 110°F (7 to 43°C).
Water-cooled: 45 to 130°F (7 to 54°C).
- F. Dryer is designed to operate at all altitudes - no adjustment for altitude is required.

NOTE: Outdoor installation—Standard units are designed for indoor installation. Contact manufacturer if installing outdoors.

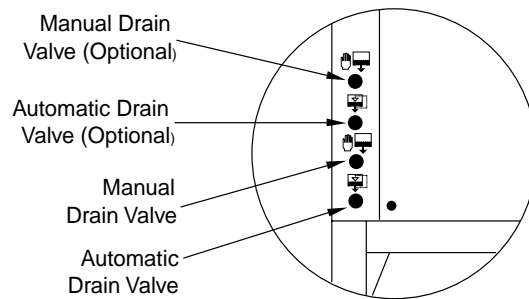
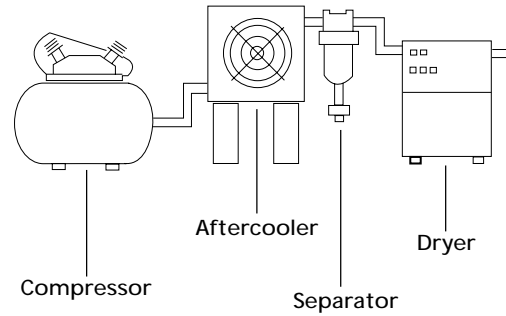

EXPLODED VIEW "A"
DRAIN VALVE CONNECTIONS

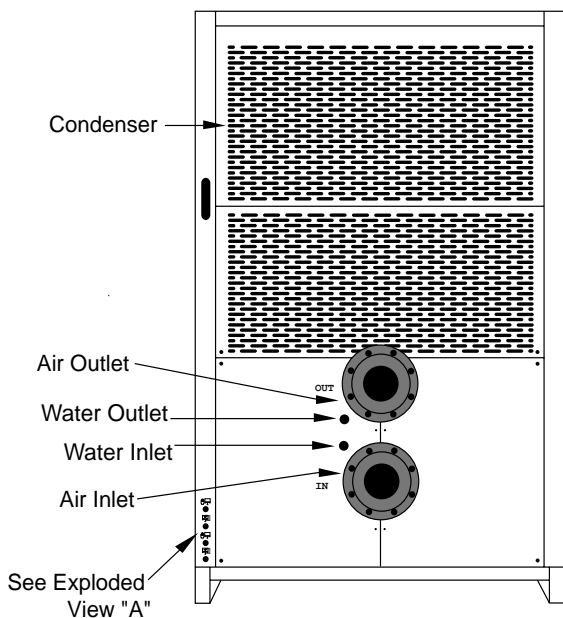

BACK VIEW

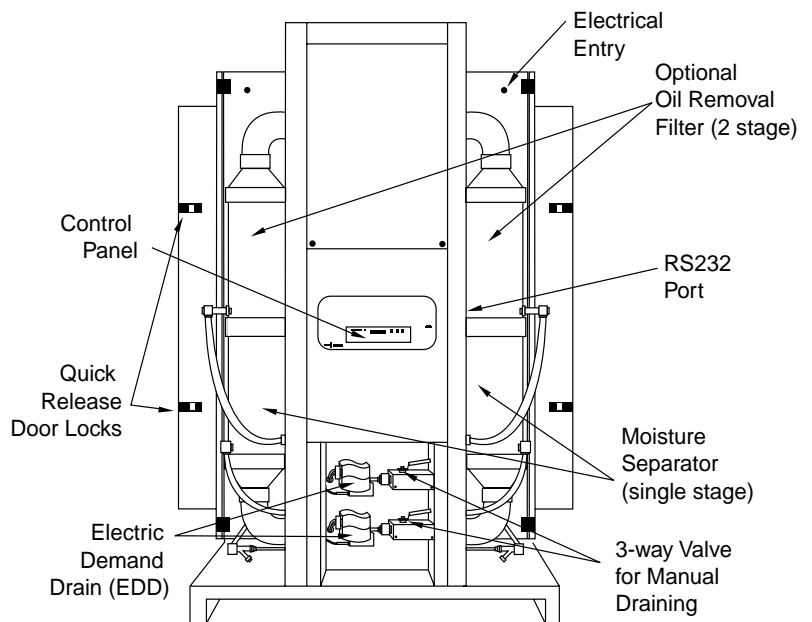

FRONT VIEW

1.2 Mounting

Mount the dryer on a level solid surface. Holes are provided in the dryer base to permanently mount the dryer to the floor.

1.3 Piping connections

- A. Air Inlet - Connect compressed air line from air source to air inlet. (See callout drawing on page 3 for air in/outlet connection locations)

⚠ WARNING Refer to Serial Number Tag for maximum working pressure. Do not exceed dryer's Maximum Working Pressure.

NOTE: Install dryer in air system at highest pressure possible (e.g. before pressure reducing valves).

NOTE: Install dryer at coolest compressed air temperature possible. Maximum inlet compressed air temperature: 120°F (49°C). If inlet air exceeds this temperature, precool the air with an aftercooler.

- B. Air Outlet - Connect air outlet to downstream air lines.
- C. By-pass piping - If servicing the dryer without interrupting the air supply is desired, piping should include inlet and outlet valves and an air by-pass valve.
- D. Water-cooled models - cooling water inlet and outlet
1. Connect cooling water supply to cooling water inlet.
 2. Connect cooling water return line to cooling water outlet connection.

NOTE: Strainer and water regulating valve are supplied on water-cooled models. Also, it is recommended to add water inlet/outlet temperature and pressure gauges to the water piping.

1.4 Electrical connections

IMPORTANT: Use copper supply wires only.

- A. Dryer is designed to operate on the voltage, phase, and frequency listed on the serial number tag.
- B. Electrical entry is through a hole in the cabinet, located in the separator compartment near the top, and in the electrical enclosure. Connect power source to the terminal strip in the electrical enclosure as shown on the electrical schematic included with the dryer. If optional disconnect is supplied, use entry hole in disconnect enclosure.

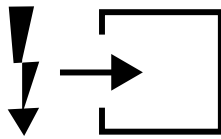

NOTE: Refrigeration condensing unit is designed to run continuously and should NOT be wired to cycle on/off with the air compressor.

1.5 Electronic Demand Drain

- A. An automatic electric demand drain (EDD) discharges condensate removed by the separator.
- B. All dryer models are supplied with one EDD. Models with the additional (optional) oil removal filter are supplied with a second EDD.

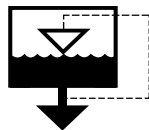

- C. At installation install the petcock on the bulkhead fitting for the manual drain. For manual draining, convenient dryer depressurization, and EDD service, a three-way valve at the bottom of the moisture separator and before the EDD is installed. For manual draining, turn the valve handle so it is in a horizontal position. Open the petcock on the side of the dryer base pan to discharge the condensate or to depressurize the dryer if it has been by-passed. The petcock can be left in a throttled (partially opened) position should there be a problem with EDD.

The drains are piped to fittings in the back leg of the unit. Condensate should be piped from this fitting to an open vented floor drain or sump.

NOTE: Discharge is at system pressure. Drain line should be anchored.

NOTE: Condensate may contain oil. Comply with applicable laws concerning proper disposal.

- D. Verify that isolation valves are open. If the drain fails to discharge after the valve is energized, the electronic control circuit will repeatedly energize the valve in an attempt to clear the discharge port. If, after 60 seconds, the drain still fails to discharge, the control circuit then switches to the alarm mode. In this mode the valve is de-energized and the red alarm light is activated on the drain and the dryer controller. The valve is then automatically energized every 4 minutes for 5 seconds. Check the drain operation. Push drain (push-to-test) button on the emm (Energy Management Monitor) control board to energize drain. A flow of condensate and/or air should be present at the drain outlet. The alarm mode automatically clears after the drain returns to normal operation.
- E. Condensate enters the reservoir (1) through the inlet port. When the condensate level in the reservoir covers the capacitance sensor, an electronic signal is sent to the solid state countdown processor. The processor delays the opening of the solenoid valve for a given period of time. Once the time has elapsed, the solid state processor transmits information to energize the coil in the solenoid valve (2). The magnetic force of the coil causes the solenoid core (3) to move, closing the pilot air supply line and opening the pilot air exhaust line. After the pilot air above the diaphragm (4) is vented, pressure in the reservoir opens the discharge port and forces the condensate through the discharge port and outlet piping.

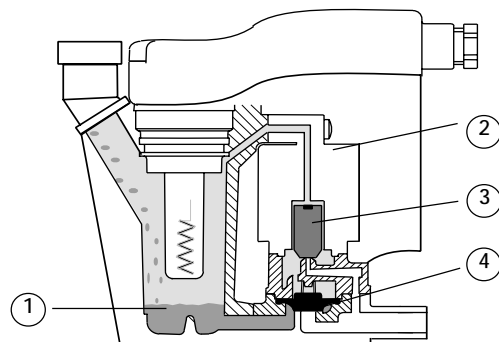

2.0 OPERATION

2.1 Minimum/Maximum operating conditions

- A. Maximum inlet air pressure: refer to dryer serial number tag
- B. Minimum inlet air pressure: 30 psig (2.1 kgf/cm²)
- C. Maximum inlet air temperature: 120°F (49°C)
- D. Maximum ambient temperature:
Air-cooled models: 110°F (43°C)
Water-cooled models: 130°F (54°C)
- E. Minimum ambient temperature: 45°F (7°C)

2.2 Start-up

- A. Energize dryer. Green power on light will illuminate.

IMPORTANT: Energize dryer disconnect switch (provided by others, sec NEC) 24 hours before refrigeration compressor is started! Never use the disconnect switch to shut-down the dryer for an extended period of time (except for repair). Failure to follow these instructions may result in a non-warrantable compressor failure.

- B. Program monitor

1. Language selection

- a. Push **Day of Week** and **Hour** buttons simultaneously until menu appears
- b. Scroll to select language (choice of 5 available: English, Spanish, French, Italian, and German) using the **Day of Week** Button
- c. Push **Set/Run** button to accept

2. Setting Functions (Clock, Schedule, and Service Reminder)

- a. Push **Set/Run** button and hold for 3 seconds to set clock
- b. Set current time using: **Day of Week**, **Hour**, and **Minute** buttons (24 hour clock)
- c. Push **Set/Run** button to set schedule
- d. Select day of week using **Day of Week** button
- e. Select on or off with **On/Off** button then set time using **Hour** and **Minute** buttons.

Repeat Steps b and c for the remaining days of the week

NOTE: Scheduler will ignore programmed commands for 10 minutes after exiting program mode

- f. Push **Set/Run** button to set service reminder
- g. Use **Hour** and **Minute** buttons to enter the number of operating hours (service interval) before service reminder is initiated. Maximum setting is 4090 hours. (Only hours that refrigeration compressor is operating are counted)

NOTE: On dryers with air-cooled condensers, regular condenser cleaning is recommended. Dirtiness of ambient air at installation site will determine frequency of service. Typically once a month is recommended. Dryers contain an integral 3 micron filter. As the filter element accumulates solid contaminants, differential pressure increases. Solid particulate load in the compressed air supply will determine frequency of service. Typically element changeout is recommended at least annually.

- h. Enable auto-restart mode if desired - toggle mode on and off by pushing the **Day of Week** Button. In the auto-restart mode, the dryer will automatically restart after a temporary loss of power. In the standard mode, the dryer will require a manual restart after a loss of power. The standard mode is recommended in most situations.

Table of Operation

After power down and restarted:

Loss of Power State	Power Up State
1 - manual mode, auto restart	manual mode, last state of compressor before loss of power
2 - manual mode, no auto restart	manual mode, compressor off
3 - schedule mode, auto restart	schedule mode, compressor on or off according to the schedule conditions
4 - schedule mode, no auto restart	manual mode, compressor off

- i. Push **Set/Run** button to exit program mode

NOTE: If Set Mode is not exited after 30 seconds, Alarm light will illuminate and TIME OUT will appear on the interface panel. Dryer will resume previous operating mode.

3. Manual Operation

- a. To manually turn the refrigeration system on or off use **On/Off** button; Push **Set/Run** button to return to schedule.

NOTE: After power interruption dryer will reenergize in Manual override, refrigeration system off. To restart Schedule: (1) if refrigeration system is scheduled to be off, Push **Set/Run** button (2) if refrigeration system is scheduled to be on, push **On/Off** button, then **Set/Run** button.

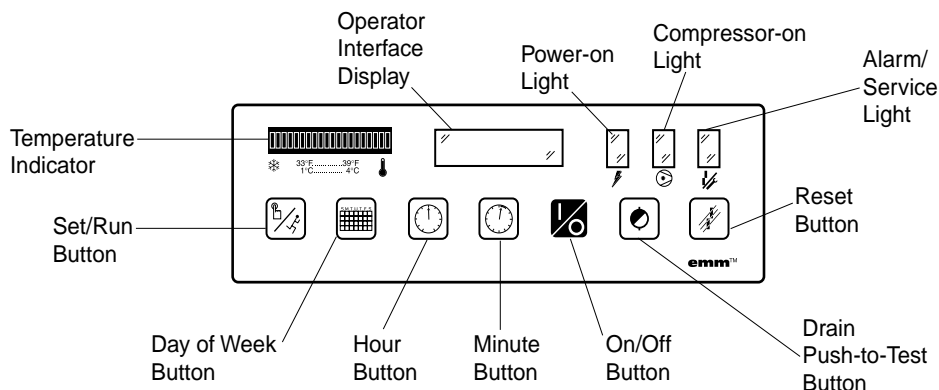

C. Starting dryer

IMPORTANT: Dryer must be energized 24 hours before starting refrigeration compressor.

NOTE: It is recommended that dryer be started 15 minutes before compressed air flow begins.

1. On water-cooled models: after 24 hours, begin cooling water flow.
2. Check for proper electrical voltage.
3. Slowly pressurize unit air side by opening inlet isolation valve. Check for leaks.
4. After 15 minutes, open outlet isolation valve slowly.
5. Close air by-pass valve.
6. Dryer may be operated in Manual or scheduled modes.

NOTE: Check for correct phasing of unit. On air-cooled models: check fan rotation (air must be pulled through the condenser.) Fans may not start immediately or may cycle on and off. If rotation is in the wrong direction follow the procedure below. On water-cooled models: After starting dryer if an unusual noise is heard and the discharge line does not get hot, stop the dryer, reverse two power leads, restart, and verify discharge line gets hot.

Manual mode - push **On/Off** button - refrigeration compressor will start and run, green Compressor-on light will illuminate. In this mode compressor will run continuously and will not be turned on and off by the monitor. MANUAL OVERRIDE will appear on interface panel.

Schedule mode - push **Set/Run** button. SCHEDULE RUNNING will appear on the interface panel. The refrigeration compressor will continue to be on or off (as selected in the Manual Override Mode) until the next scheduled event. The compressor will then turn on or off as programmed.

NOTE: Schedule may be returned to the manual mode at any time using the **On/Off** button. MANUAL OVERRIDE will appear on interface panel. To reinstitute Schedule, push the **Set/Run** button again.

NOTE: Restart after the power interruption. Unit will be in MANUAL OVERRIDE mode, refrigeration compressor, off when power is restored after power interruption.

7. To reinstitute SCHEDULE RUNNING: If compressor is scheduled to be off - push Set/Run button to restart schedule. If compressor is scheduled to be on - push **On/Off** button to manually start compressor, then push the **Set/Run** button to restart schedule.

IMPORTANT: Dryer must be energized 24 hours before refrigeration compressor is started

D. Operating check points

1. Check that green Power-on light is illuminated
2. Check that green Compressor-on light is illuminated if dryer is on in the manual mode or it is a scheduled on time

IMPORTANT: Refrigeration compressor must be restarted after power interruption.

3. Check interface panel

NOTE: Interface panel will switch between Current Time/ Operating Status screen and Hours to Service/Total Operating Hours (HRS TO SVC/TOTAL) screen. TOTAL is cumulative hours of refrigeration compressor operation.

- a. Verify that current time is correct
- b. Check HRS TO SVC: this indicates time remaining until service is required; allow time for required maintenance items to be ordered
- c. Check operating status:
MANUAL OVERRIDE - Dryer is either running continuously (not being controlled by the scheduled on/off times) or the refrigeration compressor has been shut off using the **On/Off** button.
SCHEDULE RUNNING - Refrigeration compressor is being turned on and off by the monitor per-programmed schedule (see B.2. to set schedule)
- d. Check Temperature indicator - indicator should read in the green area
- e. Check Alarm/Service light If illuminated, check Interface panel.

- 1) If SERVICE DRYER appears, scheduled maintenance time has elapsed (HRS TO SRV is 0). Perform needed service and reset service interval (see B.2.).

- 2) If ALARM appears, a dryer fault is indicated; see Troubleshooting Guide for possible remedies. After fault correction push **Reset** button to turn Fault alarm off.

Type of FAULTS:

LOW PRESSURE - the refrigeration compressor control circuit has opened because of low suction pressure. Compressor will restart automatically when fault is corrected.

HIGH PRESSURE - the refrigeration compressor control circuit has opened because of high head pressure. The high pressure switch must be reset manually once the fault is corrected. Red reset button is located on pressure switch inside unit.

LOW TEMPERATURE - compressed air temperature is below the set point

NOTE: If temperature probe is open, one light on left hand side of Temperature indicator will be illuminated.

HIGH TEMPERATURE - compressed air temperature is above the set point.

NOTE: If temperature probe is shorted, Temperature indicator will be completely illuminated.

DRAIN - electric drain contains a high water level alarm that activates if drain fails to discharge.

- f. Check drain operation - push **Drain** (push-to-test) button to energize electric drain. A flow of condensate and/or air should be present at the drain outlet.

E. Using the RS-232 port
 The RS-232 port is used to monitor dryer operation and provide remote start/stop capability from a host computer. A (1 to 1) DB-9 cable is required to connect dryer and computer. For PC connections, data is transmitted on pin 2, received on pin 3, ground is pin 5, pins 7 and 8 are jumpered at dryer.

Operation is at fixed baud rate of 2,400; asynchronous format is 8 bit, no parity, 1 stop bit ("8,N,1"). No check sum or error correction values are provided. If required, request status string two (or more) times and compare for agreement.

Request data by sending ASCII ? character (3FH). Response may take up to two seconds as certain processing functions may require completion before serial port is acknowledged.

Dryer responds with line feed (0AH), carriage return (0DH), and character string:

(1) (2) (3) (4) (5) (6) (7)
 XXX, X, XXX, X, XXXX, XXXX, X

- (1) Number of Temperature Indicator LEDs illuminated (1-20)
- (2) Compressor state, C=X (1 or 031H = ON, 0 or 030H= OFF)
- (3) Sum of alarm weights, A=XXX (0 - 255; e.g. high pressure and service alarms = 132 [4 + 128])

Bit	Weight	Alarm
2	4	High press. alarm (1 = alarm)
3	8	Low press. alarm (1 = alarm)
5	32	Drain alarm (1 = alarm)
7	128	Service (service required) alarm (1 = alarm)

For low and high temperature alarm, assign alarm to number of Temperature Indicator LEDs illuminated:
 3 = low, 20 = high

- (4) Day of week (1 = Sunday, 7 = Saturday)
- (5) Time (24 hour format, hour, minutes)
- (6) Hours to service (0-9999)
- (7) Operating mode, M=X (S = schedule running, M = manual override)

For remote start/stop operation - while powered up, operator is allowed to change to any of the following by sending the ASCII code below:

Operating State	ASCII Code
schedule mode, compressor off	"CTRL-Q"
schedule mode, compressor on	"CTRL-R"
manual mode, compressor off	"CTRL-S"
manual mode, compressor on	"CTRL-T"

F. Using the factory wired auxiliary contact (option)
 If ordered with this option the monitor is equipped with an auxiliary set of dry (volt-free) contacts (one set of normally open contacts, and one set of normally closed contacts) which can be used to operate an auxiliary device (e.g., an air line solenoid valve). Rating 5 amps @ 24VDC or 240VAC

1. These contacts can be activated in one of the following modes: (depending on options ordered)
 - a. Schedule Driven Mode - the contacts will be energized and de-energized according to the schedule inputted by the operator of the dryer. If the refrigeration compressor shuts down on a fault condition, the contacts will remain energized (or de-energized) according to the schedule. The contacts will operate independently of the refrigeration compressor in both the manual override and schedule running modes.

NOTE: The mode is factory set based on the option ordered.

- b. Dryer Driven Mode- the contacts will be energized and de-energized in parallel with the refrigeration compressor of the dryer. Therefore, if the refrigeration compressor is on, the contacts are energized; if the refrigeration compressor is off (manually or by a system fault condition), the contacts will be de-energized.

NOTE: It is the responsibility of the end-user to properly design the system control circuitry when using the auxiliary contact feature.

- c. To change the factory set Schedule Driven or Dryer Driven modes:
 1. De-energize unit and disconnect the power supply to the dryer.
 2. Remove the cabinet panels as necessary to provide access to the Monitor panel.
 3. On the rear of the circuit board, locate the jumper pins labeled JA and JB.
 4. Move the jumper to the appropriate setting:
 Schedule Driven: jumper position JA
 Dryer Driven: jumper position JB
 5. Wire the auxiliary device into the terminals 1 (Normally Open), 2 (Common) and/or 3 (Normally Closed) on the terminal block TB2. See wiring diagram for details.
 6. Reinstall the cabinet panels.
 7. Energize the unit.

3.0 MAINTENANCE

3.1 Condenser coil

- A. Air-cooled - clean off accumulated dust and dirt monthly. A factory mounted blow gun is provided for this purpose.
- B. Water-cooled - clean strainer monthly, more often if required. Shut off water, remove small plug to relieve pressure, then remove large plug to remove strainer. Clean strainer and replace.

3.2 Moisture separator/Oil filters

- A. When to replace the Separator/Filters

Replace filter element when pressure drop across dryer is excessive or annually.

Dryers have the option of one or two stages of filtration. The direction for servicing the top stage applies to both the top stage in a two-stage arrangement and the single stage in a single stage dryer.

When removing liquids at rated flow conditions, the pressure drop will be 5 psi (0.35 bar), or less, across the entire dryer. An increase in pressure drop will occur only as the separator/filter elements become loaded with solid particles. It is recommended, for maximum filtration efficiency, the separator/filter elements be replaced when the pressure drop across the dryer exceeds 10 psi (0.7 bar), or every 12 months, whichever occurs first.

- B. Description of the Separator/Filter Assembly

The separator/filter assembly consists of: the separator shell assembly (1), the upper shell cap (2), the upper shell coupling and gasket (3), the upper piping coupling and gasket (4), the element retainer plate (5), and the separator/filter elements (6).

- C. Replacement of the Separator/Filters

▲ CAUTION Depressurize the unit before servicing. Failure to do this may result in injury. The unit must be depressurized before the couplings are removed.

- a. For normal element replacement, the only assembly component that must be removed is the upper shell cap. Remove the insulation from the upper shell cap.

▲ CAUTION Check to be sure the unit is depressurized.

- b. Remove the two bolts on the upper shell coupling (3) and the upper piping coupling (4). Remove the couplings, exposing the gaskets.
- c. Slide the upper piping gasket up on to the upper piping. Slide the upper shell gasket down on to the separator shell (1). The upper shell cap (2) should now be free and removable.
- d. Remove the upper shell cap (2).
- e. Remove the element retainer plate (5).
- f. Remove the separator/filter elements (6) by simply lifting them off of the element sealing posts (1b). Discard the old elements.
- g. Inspect the inside surfaces of the separator shell (1), the element seal plate (1a), and the element sealing posts (1b).

NOTE: If the inside surfaces require additional cleaning or inspection, the entire shell assembly(1) can be removed by disassembling the lower shell coupling and gasket.

- h. Lubricate the new separator/filter element o-ring seals according to the element package instructions.
- i. Install the new elements by carefully pushing them on to the element sealing posts (1b).
- j. Reinstall the element retainer plate (5).
- k. Replace the upper shell cap (2).
- l. Inspect the upper shell cap gasket and the upper piping gasket and apply a thin coat of lubricant to the outside and to the sealing lips of these gaskets.
- m. Slide the gaskets into position, centering them between the coupling grooves.
- n. Replace the upper shell cap coupling (3) and the upper piping coupling (4). Tighten the bolts evenly and alternately.

▲ CAUTION Uneven tightening may cause the gaskets to pinch and not seal! Gasket damage may result!

- o. Reinstall the insulation.
- p. Slowly repressurize the dryer.
- q. Inspect the assembly for air leaks.

NOTE: Further disassembly is not required or recommended for maintenance.

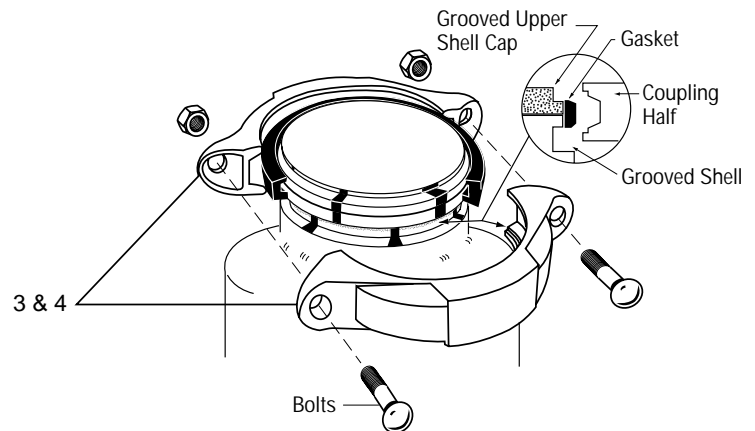

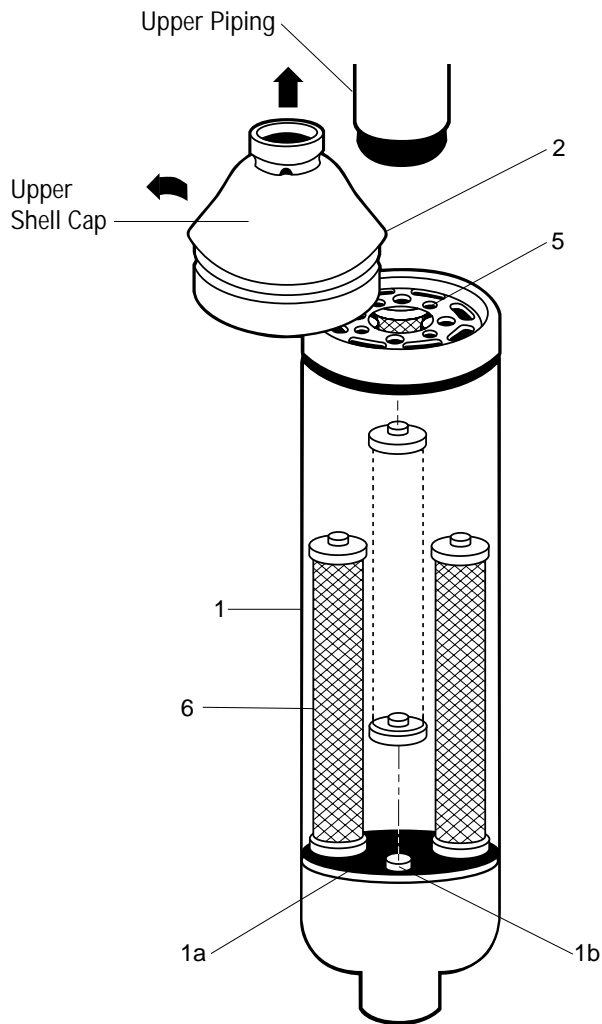

3.3 Check separator daily to be sure automatic drain is discharging.

NOTE: Units with two stage filtration have two sets of drains.

3.4 Blow down separator weekly by pushing test button on control panel.

3.5 Rebuild drain mechanism annually.

To facilitate service, maintenance kits are available.

SIZING

Determining dryer capacity at actual operating conditions

To determine the maximum inlet flow capacity of a dryer at various operating conditions, multiply the rated capacity from Table 1 by the multipliers shown in Table 2.

Example: How many scfm can an air-cooled model 1000 handle when compressed air to be dried is at 200 psig and 100°F; ambient air temperature is 80°F; and a 45°F dew point temperature is desired?

Answer: 1,000 x 1.22 x 1.12 x 1.2 = 1,640 scfm.

TABLE 1

Rated capacity (scfm) and pressure drop @ 100 psig inlet pressure, 100°F inlet temperature, and 100°F ambient temperature

MODEL		1000	1250	1500	1750	2000	2500	3000
Rated capacity of air-cooled models (scfm)	60 Hz	1000	1250	1500	1750	2000	2500	3000
	50 Hz	840	1050	1250	1460	1700	2100	2500

TABLE 2

Air capacity correction factors (Multipliers)

INLET PRESSURES		INLET COMPRESSED AIR CONDITIONS				
		INLET TEMPERATURES				
psig	kgf/cm ²	80°F 27°C	90°F 32°C	100°F 38°C	110°F 43°C	120°F 49°C
50	3.5	1.35	1.05	0.84	0.69	0.56
80	5.6	1.50	1.17	0.95	0.79	0.66
100	7.0	1.55	1.23	1.00	0.82	0.70
125	8.8	1.63	1.31	1.07	0.91	0.74
150	10.5	1.70	1.37	1.13	0.95	0.80
175	12.3	1.75	1.42	1.18	0.99	0.84
200	14.0	1.80	1.47	1.22	1.03	0.89

COOLING MEDIUM*		
AMBIENT TEMPERATURE		MULTIPLIER
°F	°C	
80	27	1.12
90	32	1.06
100	38	1.00
110	43	0.94

OUTLET DEWPOINT		
DEWPOINT TEMPERATURE		MULTIPLIER
°F	°C	
38	3	1.0
45	7	1.2
50	10	1.3

*Air-cooled models; water-cooled models use 1.15 multiplier if cooling water is below 35°C, 95°F.

ELECTRICAL SCHEMATICS

24V CONTROL CIRCUIT

LEGEND

- CON1-CONTACTOR 1, MTR1
- CON2-CONTACTOR 2, MTR2
(3000 ONLY)
- CON3-CONTACTOR 3, MTR3/5
- CON4-CONTACTOR 4, MTR4/6
- SUP -SUPPRESSOR
- HTR1/2 -HEATERS
- 1FU -FUSE, SECONDARY
- 2FU -FUSE, PRIMARY
- 3FU -FUSE, PRIMARY
- N.O.T.C -ON DELAY TIMER, MTR2
(3000 ONLY)
- FPS1-FAN PRESSURE SWITCH 1
- FPS2-FAN PRESSURE SWITCH 2
- TC1 -THERMISTOR, INSTRUMENT
PANEL
- TC2-THERMOCOUPLE, PID
- TR1 -TRANSFORMER, CONTROL
- TR2-TRANSFORMER, ISOLATION
- TR3-TRANSFORMER, ISOLATION
- TR4-TRANSFORMER, 575/460V
- SSMP-SOLID STATE MOTOR
PROTECTION
- TCB -TEMPERATURE CONTROL BOARD
- MTR1-COMPRESSOR
- MTR2-COMPRESSOR (3000 ONLY)
- MTR3-FAN1
- MTR4-FAN2
- MTR5-FAN3 (2500-3000 ONLY)
- MTR6-FAN4 (2500-3000 ONLY)
- PID -TEMPERATURE CONTROLLER
- MOL -MOTOR OVERLOAD RELAY
(EXTERNAL 2000-2500 ONLY)
- MWT -MOTOR WINDING THERMOSTAT
(INTERNAL, 2000-2500 ONLY)
- SOL -CONDENSATE DEMAND DRAIN

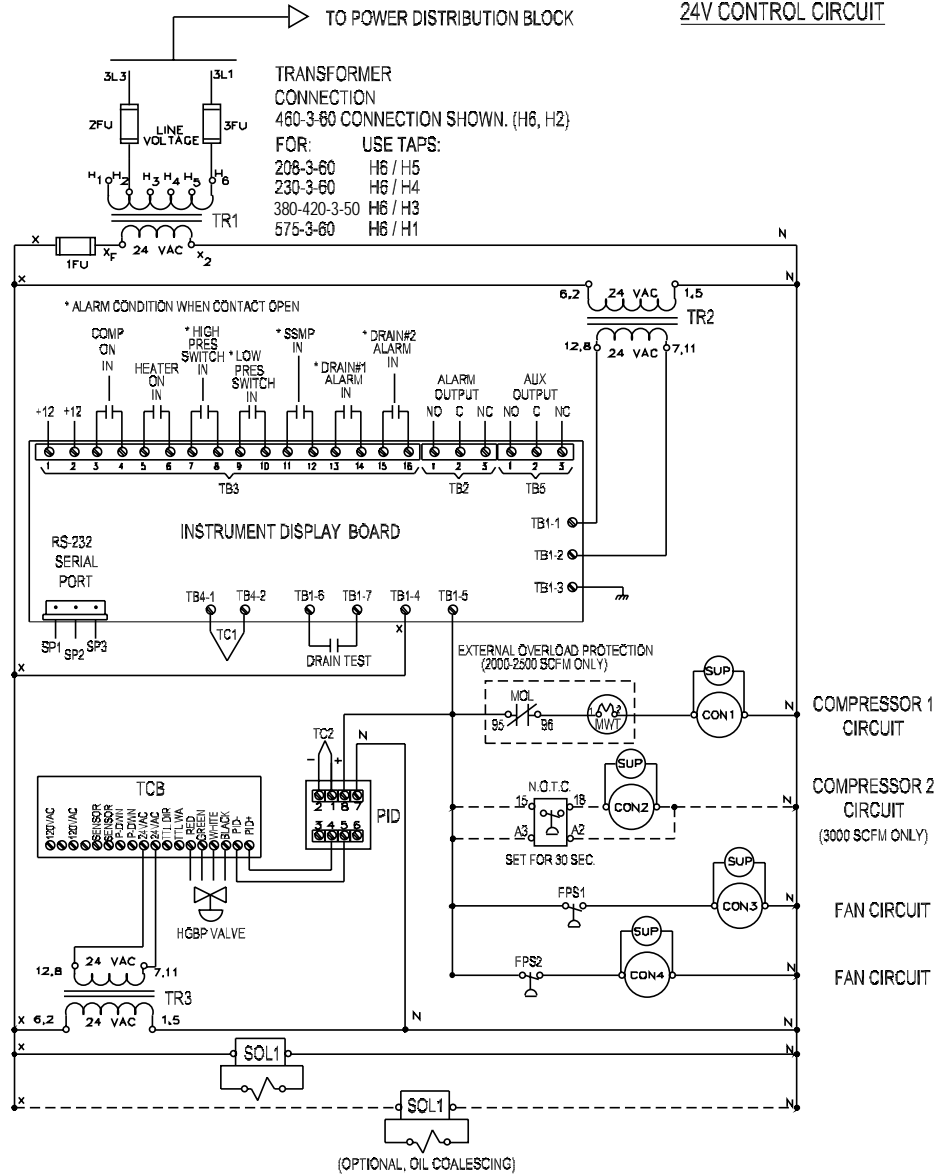

NOTES:

1. 575/3/60 APPLICATIONS: FAN MOTORS ARE 460/3/60 AND ARE SUPPLIED FROM EQUIPMENT MOUNTED TRANSFORMER.
2. FAN CONTACTORS, FAN MOTORS, FAN PRESSURE SWITCHES, AND FAN TRANSFORMERS (575V ONLY) ARE NOT USED ON WATER-COOLED UNITS.

208-230/3/60
 380-420/3/50
 460/3/60
POWER OPTION

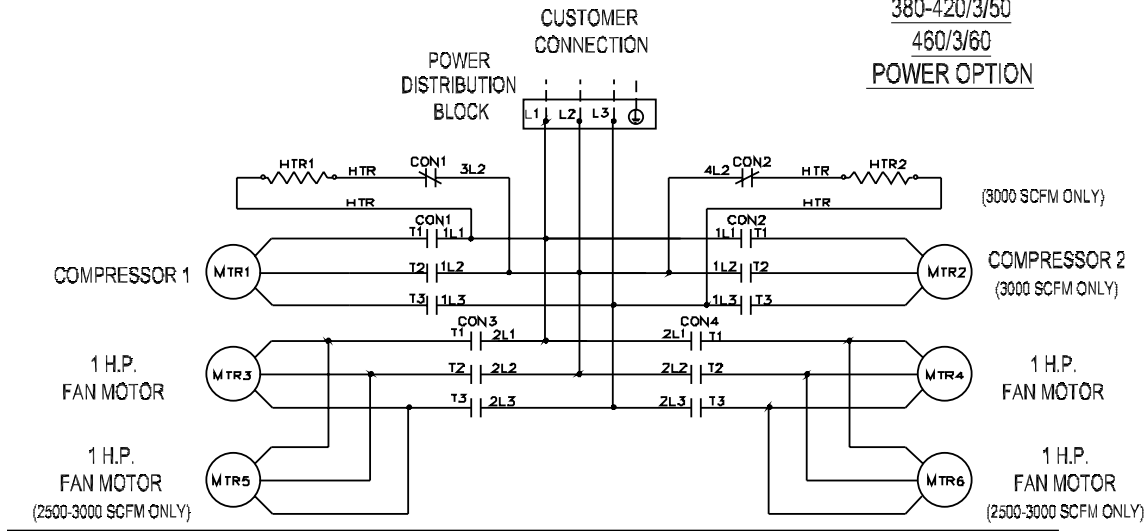

575/3/60
POWER OPTION
 (SEE NOTE 1)

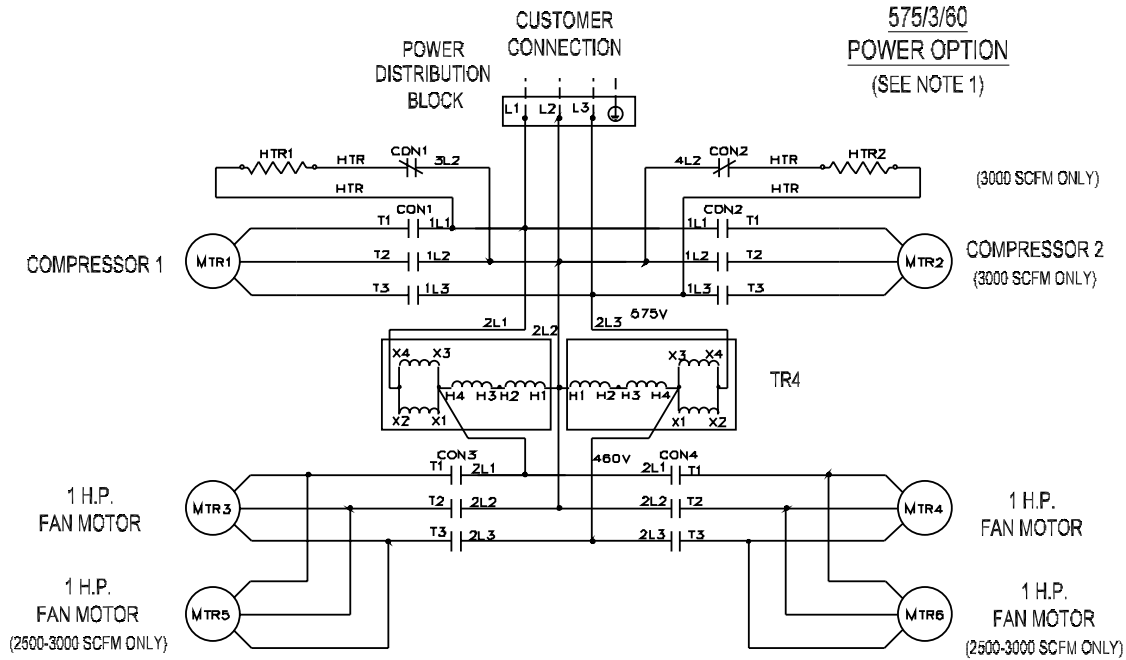

DIMENSIONS AND WEIGHTS

Model	Inlet / Outlet Connections	Dimensions in (mm)			Weight Lb. (kg)
		Height (A)	Width (B)	Depth (C)	
1000	4"	85 (2159)	48 (1207)	49 (1232)	1,720 (780)
1250	4"				1,740 (789)
1500	4"				1,850 (839)
1750	6"	85 (2159)	54 (1372)	56 (1422)	2,000 (907)
2000	6"				2,100 (953)
2500	6"				2,238 (1015)
3000	6"				2,263 (1027)

NOTE: Dimensions and weights are for reference only. Request certified drawings for construction purposes.

1000-1500 scfm

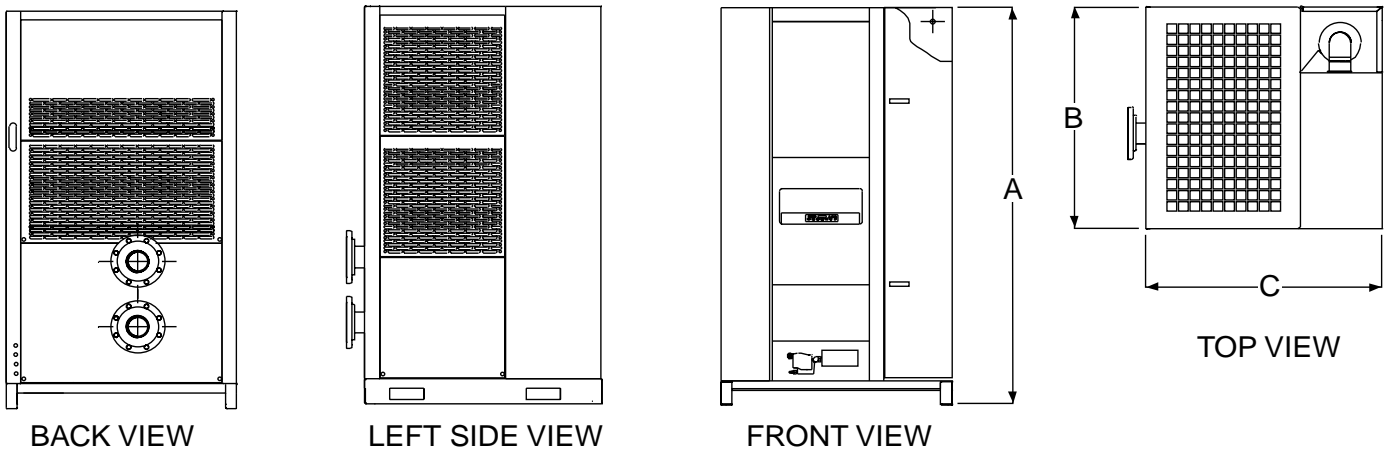

1750-3000 scfm

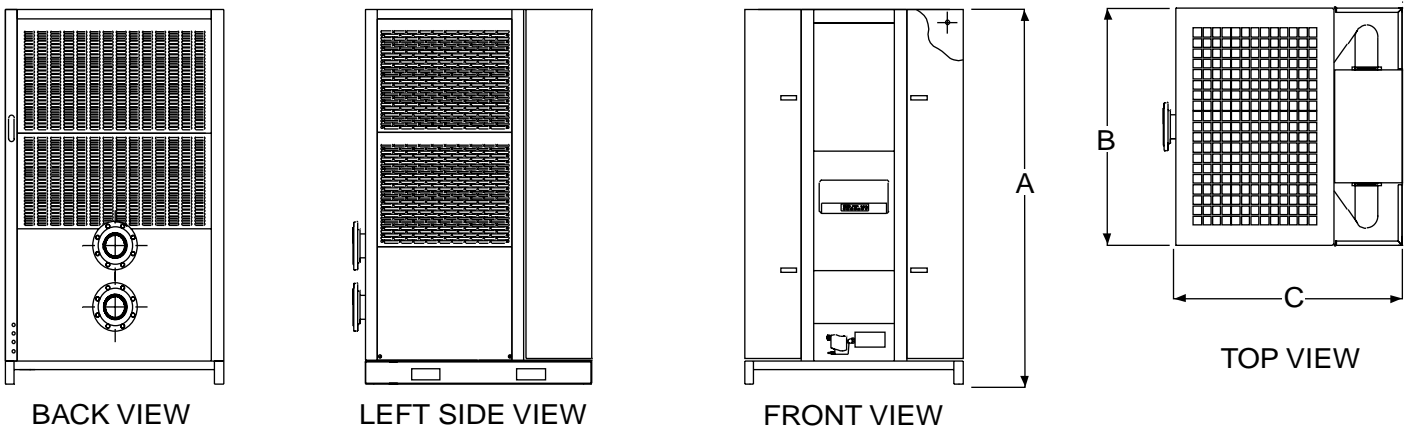

ENGINEERING DATA

	1000	1250	1500	1750	2000	2500	3000	
MINIMUM - MAXIMUM OPERATING CONDITIONS								
Min.-Max. Inlet Air Pressure (compressed air at inlet to dryer)	30-200 psig (2.1-14 kgf/cm ²)							
Max. Inlet Air Temperature (compressed air at inlet to dryer)	120°F (49°C)							
Min.-Max. Ambient Temperature	Air-cooled	45°F (7°C) - 110°F (43°C)						
	Water-cooled	45°F (7°C) - 130°F (54°C)						
REFRIGERATION SYSTEM DATA								
Compressor Type	Hermetic - Non-cycling							
Refrigeration Compressor Horsepower	6	7.5	9	10	12	15	17.5	
BTU/HR - Refrigeration Only @ 38°F PDP & 100°F Ambient	60 Hz	47,060	60,650	70,590	84,915	94,120	121,300	141,180
	50 Hz	39,217	50,542	58,825	70,763	78,433	101,083	117,650
Outlet Air Temperature (nominal at rated conditions)	85°F (29°C)							
Refrigerant Type	R-404A							
Refrigerant Charge	See dryer serial number tag							
Suction Pressure Setting	(electric hot gas by-pass valve requires no adjustment)							
Compressor Control Ranges (psig) (out-in)	High	450-348						
	Low	47-64						
Condenser Fan Switch Setting (in-out)(psig)	Fan 1	300-230						
(air-cooled models)	Fan 2	325-255						
Air Flow Across Condenser (cfm) (air-cooled models)	60/50 Hz	2800/2330	4700/3920	4700/3920	4700/3920	5600/4670	9400/7835	11,200/9335
Condenser Cooling Water Requirements (water-cooled models)								
Recommended Water Pressure (psig)	40 min. - 120 Max*							
Gallons Per Minute of Flow Required with 85°F Cooling Water	60/50 Hz	15.1/12.6	18.7/15.6	24.4/20.3	25.5/21.2	32.2/26.4	40.7/33.9	44.2/36.8
Inlet Water Connections	3/4"	1"				1-1/4"		
ELECTRICAL								
Nominal Voltage†	208-230/3/60							
Max. - Min. voltage	253-187							
Rated Load Amps**	23.9	26	31.7	33.6	52.9	62.2	59.6	
Locked Rotor Amps**	156	172	253	253	350	376	425	
Minimum Circuit Ampacity	37.9	40.5	47.6	50	74.1	92.5	89.7	
Branch Circuit Fuse Size (amps)	60	60	70	80	125	150	125	
Watts @ 35°F Evaporator & 100°F Ambient	8,480	9,860	12,140	12,780	18,960	22,100	25,640	
Resistance (ohms)	Three phase (Total) (+/- 7%)	0.501	0.412	0.31	0.27	0.22	0.158-0.18	0.412 & 0.27
Nominal Voltage	460/3/60							
Max. - Min. Voltage	506-414							
Rated Load Amps**	9.3	11	13.8	14.9	25	27.6	25.9	
Locked Rotor Amps**	70	90	118	118	158	178	208	
Minimum Circuit Ampacity	15.6	17.7	21.2	22.6	35.4	42.5	40.2	
Branch Circuit Fuse Size (amps)	20	25	35	35	60	70	60	
Watts @ 35°F Evaporator & 100°F Ambient	8,480	9,860	12,140	12,780	18,960	22,100	25,640	
Resistance (ohms)	Three phase (Total) (+/- 7%)	2.27	1.69	1.13-1.36	1.13-1.29	0.83	0.686-0.798	1.69&1.13-1.29
Nominal Voltage	575/3/60							
Max. - Min. Voltage	632-518							
Rated Load Amps**	7.9	9	10.9	12.2	20	22.1	21.2	
Locked Rotor Amps**	54	62.3	96.5	96.5	125	143	158.8	
Minimum Circuit Ampacity	13.8	15.3	17.5	19.2	29.3	35.2	34	
Branch Circuit Fuse Size (amps)	20	20	25	30	45	50	50	
Watts @ 35°F Evaporator & 100°F Ambient	8,480	9,860	12,140	12,780	18,960	22,100	25,640	
Resistance (ohms)	Three phase (Total) (+/- 7%)	3.56	2.54-2.87	1.76-2.02	1.76-2.02	1.28	1.07-1.30	2.54-2.87 & 1.76-2.02
Nominal Voltage†	380-420/3/50							
Max. - Min. Voltage	462-342							
Rated Load Amps**	9.3	11	13.8	14.9	25	27.1	25.9	
Locked Rotor Amps**	70	90	118	118	151	174	208	
Minimum Circuit Ampacity	16.1	18.1	21.6	22.9	35.7	42.2	40.8	
Branch Circuit Fuse Size (amps)	25	25	35	35	60	60	60	
Watts @ 35°F Evaporator & 100°F Ambient	6,220	7,210	8,820	9,280	10,800	14,600	16,490	
Resistance (ohms)	Three phase (Total) (+/- 7%)	2.27	1.69	1.13-1.36	1.13-1.29	0.83	0.686-0.798	1.69&1.13-1.29

* Allows continued operation with some restriction in the water strainer

** Compressor(s) only, air-cooled only

† For 208-230 ratings are for 230V input, for 380-420 ratings are for 400V input

TROUBLESHOOTING GUIDE

SYMPTOM	POSSIBLE CAUSE(S)	CORRECTIVE ACTION
A) Water downstream of dryer	<ol style="list-style-type: none"> 1. Residual free moisture remaining in downstream pipelines 2. Air bypass system is open 3. Inlet and Outlet connections are reversed 4. Air lines downstream of dryer are exposed to temperatures below the dew point. 5. Excessive free moisture (bulk liquid) at dryer inlet 6. Condensate not being drained 7. Dryer overloaded resulting in elevated dew point. 8. Refrigeration system not functioning 	<p>Blow out system with dry air</p> <p>Check valve positions Check for correct connection</p> <p>Insulate or heat trace air lines exposed to low ambients or dry air to lower dew point Install separator ahead of dryer</p> <p>See C below See C below</p> <p>See C below</p>
B) High pressure drop across dryer	<ol style="list-style-type: none"> 1. Excessive air flow 2. Freezing of moisture in evaporator because of refrigeration system fault 3. Filter loaded with solid particulates 	<p>Check flow rate</p> <p>See C below Replace filter element</p>
C) Checkpoint faults <ol style="list-style-type: none"> 1. Power on/off light 2. Compressor on light off <ol style="list-style-type: none"> 3. Alarm/Service alert light on - check Display for active conditions SERVICE DRYER <p>LOW PRESSURE</p> <p>HIGH PRESSURE NOTE: If high refrigerant pressure occurs, switch must be manually reset</p> <p>LOW TEMPERATURE (also observed as low reading on temperature indicator)</p> <p>HIGH TEMPERATURE (also observed as high reading on temperature indicator)</p> <p>DRAIN</p> <p>TIME OUT</p>	<ol style="list-style-type: none"> a. Power failure; open circuit <ol style="list-style-type: none"> a. Compressor commanded off by manual switch or programmed schedule b. Open circuit c. Control circuit open on high or low pressure cutout <p>Service interval specified has elapsed</p> <ol style="list-style-type: none"> a. Hot gas by-pass valve requires adjustment b. Low on refrigerant <ol style="list-style-type: none"> a. Lack of condenser cooling Air-cooled - Ambient temperature too high, clogged condenser fins, obstructed flow across condenser, faulty fan motor or fan control switch. Water-cooled - Cooling temperature too high, flow too low, clogged strainer, faulty water regulating valve <ol style="list-style-type: none"> a. Hot gas by-pass valve requires adjustment <ol style="list-style-type: none"> a. Dryer overloaded b. Refrigeration system off or not cooling sufficiently <ol style="list-style-type: none"> a. Drain line restricted or frozen b. Drain mechanism faulty <p>Dryer left in the Set Mode for longer than 30 seconds</p>	<p>Check for power to dryer</p> <p>Check current command status</p> <p>Check power to compressor Check display for fault</p> <p>Perform scheduled service</p> <p>Contact qualified technician or manufacturer's service department</p> <p>Check air temperature 6" in front of condenser Clean condenser and check for free air flow Check fan and switch operation Check cooling medium temperature and flow, clean strainer, check valve operation</p> <p>Contact qualified technician or manufacturer's service department</p> <p>Check compressed air flow, temperature, and pressure</p> <p>Check power to unit, power to compressor, Low or High pressure faults Have qualified technician evaluate system</p> <p>Open drain line Turn 3-way valve handle so it points out from the front of the unit. Open and adjust the manual petcock in rear leg for manual draining. Rebuild drain mechanism. Finish programing and press Set/Run button</p>

PARTS LIST

PARTS DESCRIPTION	208-230/3/60						
	1000	1250	1500	1750	2000	2500	3000
Compressor	4130.106.80	4130.107.21	4130.106.77	4130.107.23	4130.106.81	4130.107.27	4130.107.25
Fan motor	6150.238.54	6150.238.54	6150.238.54	6105.238.54	6105.238.54	6105.238.54	6105.238.54
Fan blade	4140.227.30	4140.227.30	4140.227.30	4140.227.30	4140.227.31	4140.227.30	4140.227.31
Crankcase heater	5920.330.18	5920.330.24	5920.330.24	5920.330.24	5920.330.20	5920.329.17	5920.330.24
Condenser (air-cooled)	4130.112.35	4130.112.34	4130.112.34	4130.112.30	4130.112.30	4130.112.31	4130.112.33
Low refrigerant Pressure switch	4130.138.31	4130.138.31	4130.138.31	4130.138.31	4130.138.31	4130.138.31	4130.138.31
High refrigerant Pressure switch	4130.138.28	4130.138.28	4130.138.28	4130.138.28	4130.138.28	4130.138.28	4130.138.28
Fan cutout switch 1	4130.138.26	4130.138.26	4130.138.26	4130.138.26	4130.138.26	4130.138.26	4130.138.26
Fan cutout switch 2	4130.138.27	4130.138.27	4130.138.27	4130.138.27	4130.138.27	4130.138.27	4130.138.27
*Maintenance Kits-Single Stage	KRDKT10.5	KRDKT10.5	KRDKT10.5	KRDKT11.5	KRDKT11.5	KRDKT11.5	KRDKT11.5
*Maintenance Kits-2 stage	KRDKT12	KRDKT12	KRDKT12	KRDKT13	KRDKT13	KRDKT13	KRDKT13

PARTS DESCRIPTION	380-420/3/50, and 460/3/60						
	1000	1250	1500	1750	2000	2500	3000
Compressor	4130.106.83	4130.107.19	4130.106.76	4130.107.20	4130.106.53	4130.107.18	4130.107.17
Fan motor	6150.238.54	6150.238.54	6150.238.54	6105.238.54	6105.238.54	6105.238.54	6105.238.54
Fan blade	4140.227.30	4140.227.30	4140.227.30	4140.227.30	4140.227.31	4140.227.30	4140.227.31
Crankcase heater	5920.330.16	5920.329.16	5920.329.16	5920.329.16	5920.330.17	5920.329.15	5920.329.16
Condenser (air-cooled)	4130.112.35	4130.112.34	4130.112.34	4130.112.30	4130.112.30	4130.112.31	4130.112.33
Low refrigerant Pressure switch	4130.138.31	4130.138.31	4130.138.31	4130.138.31	4130.138.31	4130.138.31	4130.138.31
High refrigerant Pressure switch	4130.138.28	4130.138.28	4130.138.28	4130.138.28	4130.138.28	4130.138.28	4130.138.28
Fan cutout switch 1	4130.138.26	4130.138.26	4130.138.26	4130.138.26	4130.138.26	4130.138.26	4130.138.26
Fan cutout switch 2	4130.138.27	4130.138.27	4130.138.27	4130.138.27	4130.138.27	4130.138.27	4130.138.27
*Maintenance Kits-Single Stage	KRDKT10.5	KRDKT10.5	KRDKT10.5	KRDKT11.5	KRDKT11.5	KRDKT11.5	KRDKT11.5
*Maintenance Kits-2 stage	KRDKT12	KRDKT12	KRDKT12	KRDKT13	KRDKT13	KRDKT13	KRDKT13

PARTS DESCRIPTION	575/3/60						
	1000	1250	1500	1750	2000	2500	3000
Compressor	4130.106.79	4130.107.22	4130.106.78	4130.107.24	4130.106.82	4130.107.28	4130.107.26
Fan motor	6150.238.54	6150.238.54	6150.238.54	6105.238.54	6105.238.54	6105.238.54	6105.238.54
Fan blade	4140.227.30	4140.227.30	4140.227.30	4140.227.30	4140.227.31	4140.227.30	4140.227.31
Crankcase heater	5920.330.19	5920.330.25	5920.330.25	5920.329.25	5920.330.21	5920.329.18	5920.330.25
Condenser (air-cooled)	4130.112.35	4130.112.34	4130.112.34	4130.112.30	4130.112.30	4130.112.31	4130.112.33
Low refrigerant Pressure switch	4130.138.31	4130.138.31	4130.138.31	4130.138.31	4130.138.31	4130.138.31	4130.138.31
High refrigerant Pressure switch	4130.138.28	4130.138.28	4130.138.28	4130.138.28	4130.138.28	4130.138.28	4130.138.28
Fan cutout switch 1	4130.138.26	4130.138.26	4130.138.26	4130.138.26	4130.138.26	4130.138.26	4130.138.26
Fan cutout switch 2	4130.138.27	4130.138.27	4130.138.27	4130.138.27	4130.138.27	4130.138.27	4130.138.27
*Maintenance Kits-Single Stage	KRDKT10.5	KRDKT10.5	KRDKT10.5	KRDKT11.5	KRDKT11.5	KRDKT11.5	KRDKT11.5
*Maintenance Kits-2 stage	KRDKT12	KRDKT12	KRDKT12	KRDKT13	KRDKT13	KRDKT13	KRDKT13

* Single stage is the moisture separator, 2 stage includes the optional oil removal filter.

The maintenance kits 10.5 and 11.5 are for units equipped with 34" tall separators that use two elements per shell, the other kits are for 21" tall separators that use four elements per shell.

WARRANTY

The manufacturer warrants the product manufactured by it, when properly installed, operated, applied, and maintained in accordance with procedures and recommendations outlined in manufacturer's instruction manuals, to be free from defects in material or workmanship for a period as specified below, provided such defect is discovered and brought to the manufacturer's attention within the aforesaid warranty period.

The manufacturer will repair or replace any product or part determined to be defective by the manufacturer within the warranty period, provided such defect occurred in normal service and not as a result of misuse, abuse, neglect or accident. Normal maintenance items requiring routine replacement are not warranted. The warranty covers parts and labor for the warranty period unless otherwise specified. Repair or replacement shall be made at the factory or the installation site, at the sole option of the manufacturer. Any service performed on the product by anyone other than the manufacturer must first be authorized by the manufacturer.

Unauthorized service voids the warranty and any resulting charge or subsequent claim will not be paid. Products repaired or replaced under warranty shall be warranted for the unexpired portion of the warranty applying to the original product.

The foregoing is the exclusive remedy of any buyer of the manufacturer's product. The maximum damages liability of the manufacturer is the original purchase price of the product or part.

THE FOREGOING WARRANTY IS EXCLUSIVE AND IN LIEU OF ALL OTHER WARRANTIES, WHETHER WRITTEN, ORAL, OR STATUTORY, AND IS EXPRESSLY IN LIEU OF THE IMPLIED WARRANTY OF MERCHANTABILITY AND THE IMPLIED WARRANTY OF FITNESS FOR A PARTICULAR PURPOSE. THE MANUFACTURER SHALL NOT BE LIABLE FOR LOSS OR DAMAGE BY REASON OF STRICT LIABILITY IN TORT OR ITS NEGLIGENCE IN WHATEVER MANNER INCLUDING DESIGN, MANUFACTURE OR INSPECTION OF THE EQUIPMENT OR ITS FAILURE TO DISCOVER, REPORT, REPAIR, OR MODIFY LATENT DEFECTS INHERENT THEREIN.

THE MANUFACTURER, HIS REPRESENTATIVE OR DISTRIBUTOR SHALL NOT BE LIABLE FOR LOSS OF USE OF THE PRODUCT OR OTHER INCIDENTAL OR CONSEQUENTIAL COSTS, EXPENSES, OR DAMAGES INCURRED BY THE BUYER, WHETHER ARISING FROM BREACH OF WARRANTY, NEGLIGENCE OR STRICT LIABILITY IN TORT.

The manufacturer does not warrant any product, part, material, component, or accessory manufactured by others and sold or supplied in connection with the sale of manufacturer's products.

Warranty Period

Parts and labor for two (2) years from the date of shipment from the factory; heat exchangers are covered (parts only) for an additional three (3) years (total of five [5]). On units that manufacturer requests be returned to the factory, a one time removal/reinstallation labor allowance as noted in the Service Warranty Policies and Procedures Handbook will apply. Freight to the factory from the installation site and to the installation site from the factory will be paid by the manufacturer; means of transportation to be specified by manufacturer.

AUTHORIZATION FROM THE SERVICE DEPARTMENT IS NECESSARY BEFORE MATERIAL IS RETURNED TO THE FACTORY OR IN-WARRANTY REPAIRS ARE MADE.



SERVICE DEPARTMENT: (724) 745-3038

3760 Rue La Verendrye • Boisbriand (Quebec) J7H 1R5
Tel: 450-971-1414 • Fax: 450-971-1415