

# SERVICE MANUAL

USE

## Refrigerated Dryer

**Model: TE 91**

GL-Nr.: 1\_8037\_10010 01

Serial No.: .....



# Table of Contents

Chapter – Page

<b>1</b>	<b>Technical Specification</b>	<b>1 – 1</b>
1.1	Refrigerated Dryer	1 – 1
1.2	Compressed Air System	1 – 1
1.3	Refrigerant System	1 – 1
1.4	Installation Requirements	1 – 1
1.5	Connections	1 – 1
1.6	Electrical Connection	1 – 2
1.7	Settings	1 – 2
1.8	Designation	1 – 2
1.9	Dimensional Diagram	1 – 2
1.10	Bypass 2 NPT	1 – 4
<b>2</b>	<b>Safety Regulations</b>	<b>2 – 5</b>
2.1	Explanation of Symbols and References	2 – 5
2.2	General Safety Instructions	2 – 5
2.3	Refrigerant	2 – 6
2.4	First Aid after Contact with Refrigerant	2 – 7
2.5	Spare Parts	2 – 7
2.6	Environmental Protection	2 – 7
<b>3</b>	<b>General</b>	<b>3 – 8</b>
3.1	Proper use	3 – 8
3.2	Improper use	3 – 8
3.3	Copyright	3 – 8
<b>4</b>	<b>Transport</b>	<b>4 – 9</b>
4.1	Transport Instructions	4 – 9
4.2	Packaging	4 – 9
4.3	Temporary Storage	4 – 10
<b>5</b>	<b>Construction and Operation</b>	<b>5 – 11</b>
5.1	Construction	5 – 11
5.2	Functional Description	5 – 11
5.3	Refrigerant Circulation	5 – 12
5.4	Component Identification	5 – 13
5.5	Pipe and Instrument Flow Chart (P & I Flow Chart)	5 – 13
<b>6</b>	<b>Installation</b>	<b>6 – 16</b>
6.1	Installation Requirements	6 – 16
6.2	Compressed Air Connection	6 – 17
6.3	Condensate Drain Connection	6 – 17
6.4	Electrical Connection	6 – 18
6.5	Voltless Contacts	6 – 18

# Table of Contents



Chapter – Page

<b>7</b>	<b>Preparation For Initial Start Up</b>	<b>7 – 19</b>
7.1	Points to be Observed before Start Up	7 – 19
7.2	Points to be Observed before Switching On:	7 – 19
7.3	Ready for Operation	7 – 20
<b>8</b>	<b>Operation</b>	<b>8 – 21</b>
8.1	Instrument Panel	8 – 21
8.2	Starting the Refrigerated Dryer	8 – 22
8.3	Stopping the Refrigerated Dryer	8 – 23
8.4	Trouble shooting	8 – 24
8.4.1	Water in the compressed air system	8 – 24
8.4.2	High pressure losses via the refrigerated dryer	8 – 24
8.4.3	Pressure dew point too high	8 – 24
8.4.4	High compressed air losses	8 – 25
8.4.5	Red LED on the ECO–DRAIN housing flashes	8 – 25
8.4.6	The safety pressure switch shuts down the refrigerated dryer	8 – 25
<b>9</b>	<b>Maintenance</b>	<b>9 – 26</b>
9.1	Maintenance Instructions:	9 – 26
9.2	Regular Maintenance	9 – 26
9.2.1	General checks	9 – 27
9.2.2	Cleaning the condenser	9 – 27
9.2.3	Check the condensate outlet daily as follows:	9 – 27
9.2.4	Functional check of the ECO–DRAIN	9 – 27
9.2.5	Cleaning the ECO–DRAIN	9 – 27
<b>10</b>	<b>Spare Parts and After Sales Service</b>	<b>10 – 29</b>
<b>11</b>	<b>Appendix</b>	<b>11 – 30</b>
11.1	Wiring Diagram	11 – 30
11.2	Maintenance Schedule	11 – 41
11.3	Installation and Service Manual for ECO–DRAIN	11 – 42

## 1 Technical Specification

### 1.1 Refrigerated Dryer

Model .....	TE 91
Condensate volume under nominal conditions* .....	112 oz/h
Weight .....	1256 lbs
Cooling air volume .....	2118 cfm
Noise level to CAGI–Pneurop .....	< 70 dB(A)
at 1 m distance (free sound field measurement)	

\* See chapter 1.2 for nominal conditions.

#### Drawings:

P & I flow chart .....	FKTTE91ST–00020.00
(Pipework and instrument flow chart)	
Electrical diagram .....	STE–U0909.00
Dimensional drawing .....	T 9156.2
By-pass piping .....	203990.0

### 1.2 Compressed Air System

Flow volume .....	360 scfm
Pressure drop .....	1.45 psid
Pressure dewpoint .....	35 °F
at 100 °F air inlet, 100 psig and 100 °F ambient temperature.	
Maximum gauge working pressure .....	190 psig

### 1.3 Refrigerant System

Refrigerant .....	R 134a
Maximum quantity .....	4.77 lbs
Permissible gauge working pressure .....	260 psig

### 1.4 Installation Requirements

Max. elevation above sea level of installation .....	3000 ft.
(for all elevations above please contact authorized KAESER distributor)	
Min. ambient temperature .....	40 °F
Max. ambient temperature .....	110 °F
Maximum compressed air inlet temperature .....	130 °F

### 1.5 Connections

Compressed air outlet .....	2 NPT
Condensate drain connection (hose connection) .....	3/8
Service connection (Schrader valve) .....	7/16 UNF

**1.6 Electrical Connection**

Main voltage .....	460 V ± 10 % 3-phase
Full load current, FLA .....	2.5 A
Frequency .....	60 Hz
Recommended main disconnect fuses (Dual element or time-delay) .....	5 A
Recommended power supply cable (Cu multi-stranded ) cross-section .....	14 AWG

**Attention!**

**Maximum dual element time-delay fuses are selected according to 1996 N.E.C. Article 240-6, 430-52 and Tables 430-148 & 150.**

**Select multi-strand copper core wire at 40°C ambient temperature according to 1996 N.E.C. 110-14(c), 220-3, 310-15, Table 310-16, 430-6, 430-22 and Tables 430-148 & 150.**

**1.7 Settings****Safety pressure switch (refrigerant)**

switching point (fixed)

P<sub>OFF</sub> ..... 265 psi**Thermostat**

regulates pressure dewpoint to ..... ca. 35 °F

**1.8 Designation**

The nameplate of the refrigerated dryer is located on the front left below the cooling air inlet (see chapter 10 for an illustration of the nameplate).

**1.9 Dimensional Diagram**

(see next page)

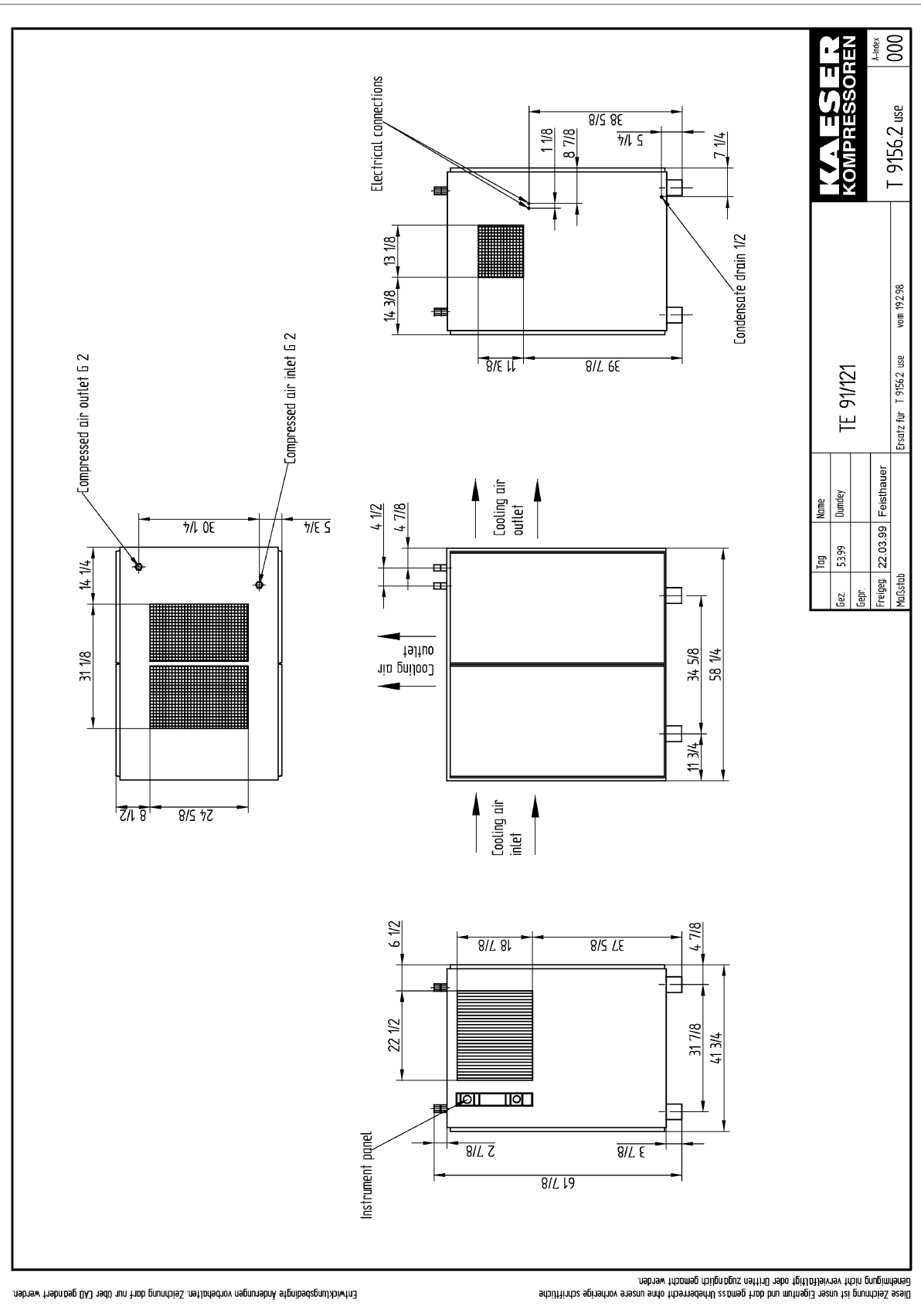

<b>KAESER</b> KOMPRESSOREN		TE 911/21		A-Index: 000	
Titel	Name	Ersatz für T 9156.2 use vom 19.2.98			
Erz.	Dumrey				
Gepr.	Feisthauer				
Freigeig.	22.03.99				
Maßstab					

This drawing is our property and may be used only for the purpose for which it was made. Any reproduction or use without our written permission is prohibited. We accept no liability for errors or omissions. The drawing may be modified without notice.

1.10 Bypass 2 NPT

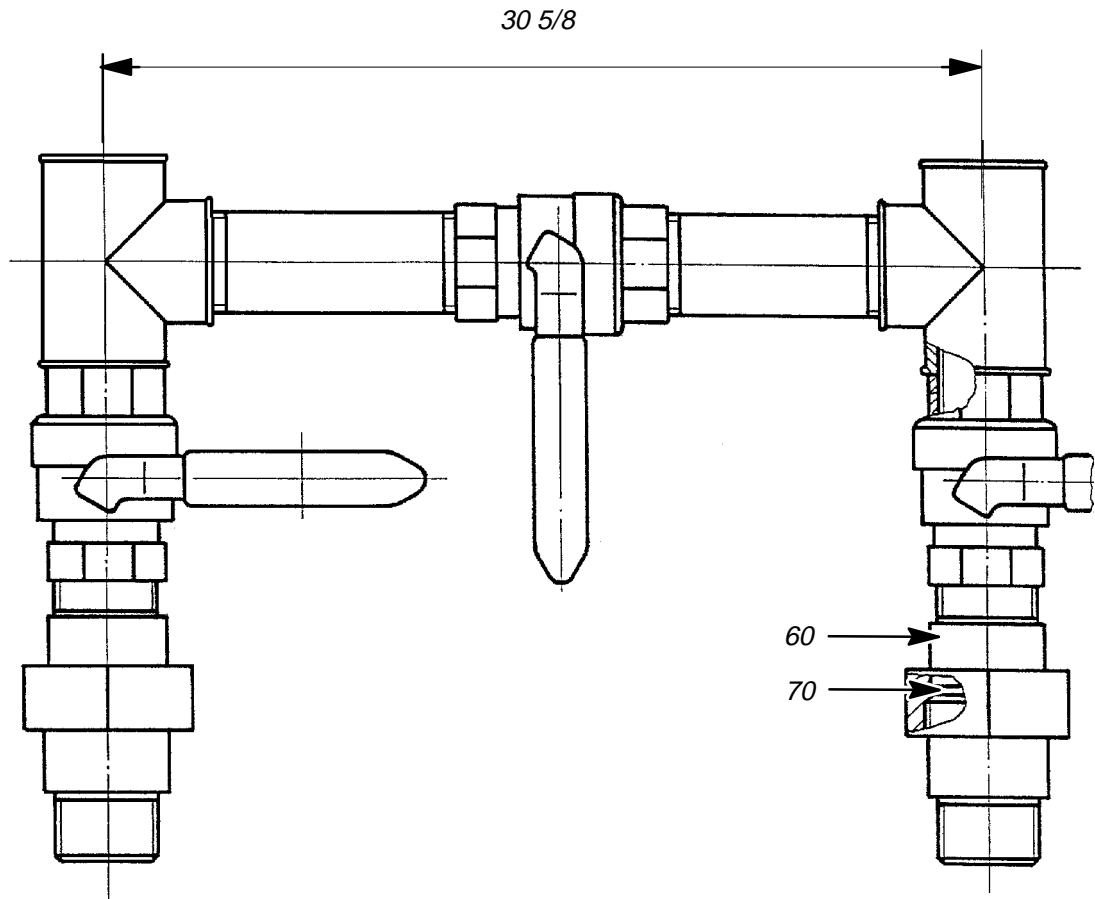



## 2 Safety Regulations

Read this service manual very carefully and observe all cautionary references before the initial start of this refrigerated dryer and before carrying out any maintenance on the unit.

### 2.1 Explanation of Symbols and References



This symbol is placed before all safety references where there is danger to life and limb. It is especially important that any associated instructions are followed explicitly and that extreme care is taken when performing the indicated task(s). For their own protection, inform all other users of these safety rules. Observe general safety and accident prevention regulations as well as the safety rules laid down in this service manual.

**Attention!**

This symbol is placed by text where considerable attention must be paid to recommendations, regulations, references and correct sequence so that damage and/or destruction of the compressor and/or other equipment is prevented.



This symbol identifies environmental care measures.



This symbol indicates operations to be carried out by the operator or service technician.

- This bullet identifies listings.

### 2.2 General Safety Instructions



Work on power driven systems may only be carried out by trained or instructed personnel or by specialized personnel.

Work on the electrical equipment of the refrigerated dryer may only be carried out by a qualified electrician or trained personnel under the supervision of a qualified electrician according to the NEC and any applicable local codes.

Work on the refrigeration system may only be carried out by a certified refrigeration technician (according to 40CFR Part 82).

**Further points to be observed:**

- No open flame or sparks at the point of installation.
- The maximum ambient temperature may not be exceeded (see chapter 1.4), otherwise special measures must be agreed between the manufacturer and the user.
- This unit is not explosion-protected and may not be operated in hazardous areas.

**Attention!**

The refrigerated dryer contains live electrical components.



Prior to working on electrical systems of the compressor always perform the following steps in the sequence shown.

1. Lock the main disconnect in the "off" position in accordance with applicable lock out/ tag out procedures (example: OSHA CFR 29 § 1910.147) to ensure the compressor does not restart.
2. Ensure the package cannot be switched on again
3. Check that no voltage is present
4. Lock the isolation shut-off valve in the "closed" position and vent all compressed air trapped between the compressor and the isolation shut-off valve in accordance with applicable lock out/ tag out procedures (example: OSHA CFR 29 § 1910.147).



The refrigerated dryer contains systems subject to high pressures. Before any maintenance work is carried out, vent and shut off all pipe-work under pressure.



Do not weld or braze on any pressurized components (e.g., pipes, tanks, fittings) or make any modifications that require heat treatment.

**Attention!**

Safety devices may not be modified or deactivated.

Signs and labels of reference may not be removed or rendered unreadable.

**Attention!**

Any alterations or reconstruction carried out without consultation with and the previous consent of KAESER COMPRESSORS will invalidate the warranty.

## 2.3 Refrigerant



Initial startup of and maintenance work on the refrigerant circuit may only be carried out by persons who have been trained in the safety concepts of refrigeration engineering.



Escaping compressed air and/or refrigerant can cause injury, frostbite, burns and lead to damage to the unit. Safety data sheets explaining how to deal with refrigerant are available from KAESER COMPRESSORS Inc.



The refrigerant contained in the refrigerating system may not be vented to the open air. Always use a refrigerant recovery system when working on the refrigerant circulation. Dispose of unusable refrigerant according to environmental regulations!

## 2.4 First Aid after Contact with Refrigerant

General: Remove damp clothing.

### Inhalation:

- ☞ Remove victim to the fresh air.  
Obtain medical attention in the case of breathing difficulties or nervous symptoms.

### Skin:

- ☞ Rinse area with plenty of warm water.  
Treat frostbite the same as burns. Obtain medical attention if pain persists or skin reddens.

### Eyes:

- ☞ Open eyelids wide to allow product to evaporate.  
Rinse immediately with open eyelids and plenty of running water for at least 10 minutes and seek medical advice if pain persists.

## 2.5 Spare Parts

The use of KAESER original parts guarantees safe and reliable operation of the refrigerated dryer.

## 2.6 Environmental Protection

### Condensate drainage



The condensate accumulated during the drying of compressed air must be removed via a suitable drainage system, collected in special canisters and disposed of according to federal and local environmental regulations.

### Maintenance materials/wear items/replacement parts



Ensure that all wear items, maintenance and replacement parts accumulated during operation of the refrigerated dryer are disposed of according to environmental regulations.

### 3 General



**The service manual must always be available for use at the location of the refrigerated dryer.**

#### 3.1 Proper use

The refrigerated dryer is intended solely for drying compressed air.

Any other use outside of this purpose is considered improper. The manufacturer cannot accept liability for any damage caused by improper use; the user alone is liable for any risks incurred.

Proper use of the dryer includes compliance with the installation, removal, servicing, operation and maintenance instructions as specified by the manufacturer.

#### 3.2 Improper use



**Never direct compressed air toward persons. Compressed air is a concentrated form of energy and as such is dangerous to life.**

#### 3.3 Copyright

© KAESER COMPRESSORS, INC.

All rights reserved. No part of this manual may be reproduced in any form without permission of KAESER COMPRESSORS, INC.

## 4 Transport

### 4.1 Transport Instructions

**Attention!**

Under no circumstances lift the refrigerated dryer with the compressed air inlet and outlet connections or lay the refrigerated dryer on its side. Serious damage can result from such treatment of the refrigerated dryer.

To prevent damage to the panelling of the refrigerated dryer always use a jack lift or a forklift truck for transport.

- Always mount the refrigerated dryer on a suitable transporting medium (pallet or wooden base) during transport.

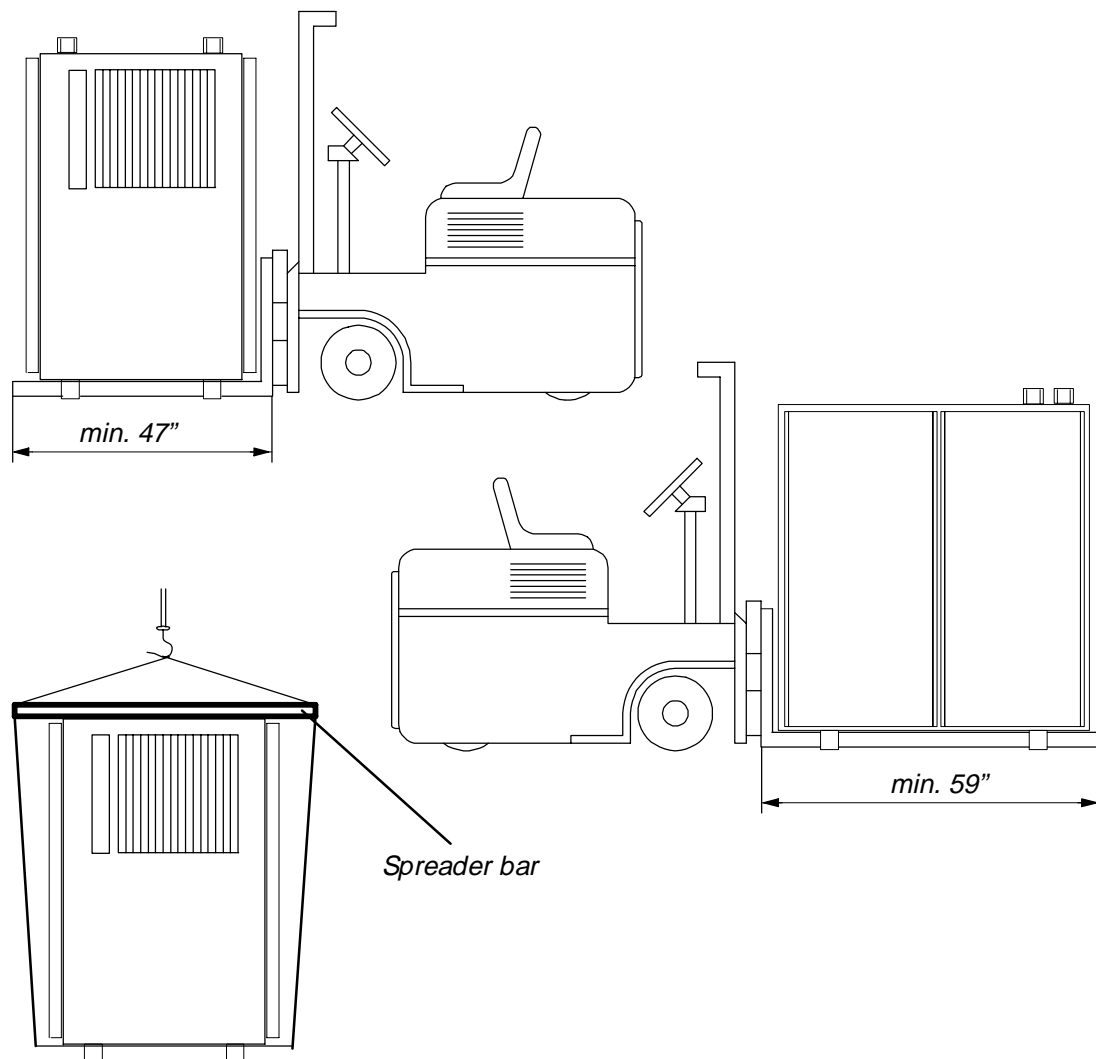
**Attention!**

Do not exert any side forces on the refrigerated dryer with lifting equipment.

### 4.2 Packaging

The packaging provided with this compressor as delivered is intended to safeguard the package against normal road transport damage. Please dispose of in an environmentally friendly way and arrange for it to be recycled if possible.

### 4.3 Temporary Storage

Store the refrigerated dryer in an enclosed space, regardless of whether it is packaged or not.

The storage temperature should not fall below  $-13^{\circ}\text{F}$  and not rise above  $140^{\circ}\text{F}$ .

**Attention!**

**Before initial start, wait until the temperature of the refrigerated dryer has adapted to the ambient temperature.**

## **5 Construction and Operation**

Items referred to in ( ) correspond with the items in the Pipe and Instrument Flow Diagram (see chapter 5.5).

### **5.1 Construction**

The main component of the refrigerated dryer comprises a combined heat exchanger (heat transmitter). It consists of the two following main groups:

1st. stage: air to air heat exchanger (1)

2nd. stage: air to refrigerant heat exchanger (2)

A condensate separating system (3) is fitted in series with the heat exchanger.

A safety pressure switch (9) is fitted in the refrigerant circulation system as a protection against excessive pressure.

A thermal overload switch protects the refrigerant compressor (11) against current overloads and high temperatures.

The refrigerant circulation is automatically regulated with a thermostat (13).

### **5.2 Functional Description**

The dried compressed air is then rewarmed by flowing through the air to air heat exchanger (1) before leaving the refrigerated dryer.

The warm compressed air of high humidity entering the unit is initially cooled in the air to air heat exchanger (1) through heat exchange with the cooled compressed air leaving the unit.

The moisture precipitated in the air to air heat exchanger is drained via an automatic condensate drain (5).

Further cooling occurs in the air to refrigerant heat exchanger (2), connected in series with the air to air heat exchanger through the action of expanding, gassing refrigerant. This action causes the humid components of the compressed air to condense out when the pressure dewpoint is undercut.

The condensate separator, (3) connected in series, separates the condensed water and oil droplets, together with coarse dirt particles, from the compressed air. This condensate is removed from the system by an automatic condensate drain (5).

The cooling action of the refrigerated dryer causes the condensation and subsequent separation of the humid content of the compressed air.

The refrigerant compressor (11) is switched off by a thermostat if the refrigeration demand sinks and switched on again when the demand rises. Considerable savings in energy are possible with this principle of operation.

### **5.3 Refrigerant Circulation**

The dryer is able to cool the compressed air by using a refrigeration system not unlike a typical home refrigerator. Cooling is achieved by transferring heat from the compressed air to the refrigerant by vaporizing (boiling) the refrigerant, thereby turning the refrigerant into a gas. A more complete description of this process is given below:

The refrigerant enters the hermetically sealed compressor (11) as a low pressure gas. The gas is compressed to a suitable pressure to ensure that the gas is nearly saturated. The high pressure refrigerant gas flows to the condenser (10) where heat is removed from the refrigerant. As the high pressure refrigerant gas is cooled, the refrigerant becomes a liquid.

The high pressure liquid is then forced through a capillary tube (7). By forcing the refrigerant through this restriction, the refrigerant becomes a low pressure liquid. The low pressure, liquid refrigerant enters the evaporator (2) where heat from the compressed air is transferred to the refrigerant. The added heat causes the refrigerant to boil and results in the refrigerant becoming a low pressure gas. This becomes an endless cycle which allows the refrigerant to simply remove heat from the compressed air and expel it to the ambient air.



**5.4 Component Identification**

Numbers in ( ) correspond to those in the Pipe and Instrument Flow Chart.  
(P & I Flow Chart).

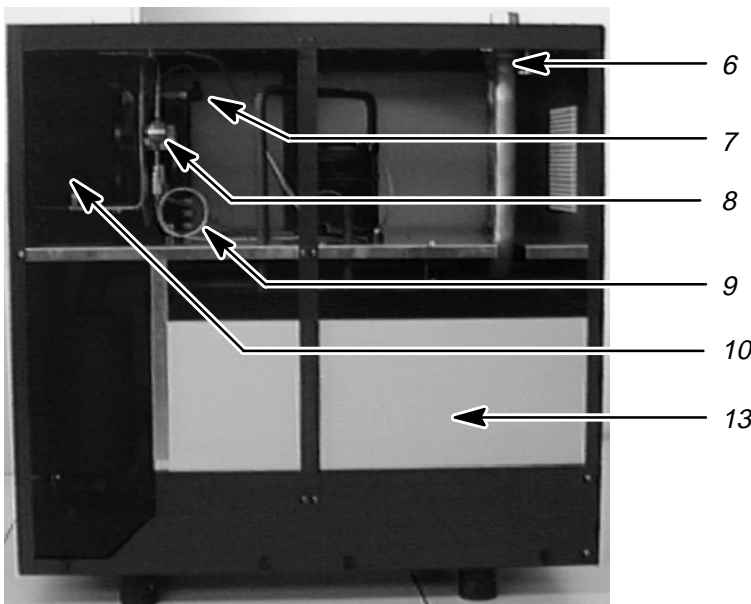
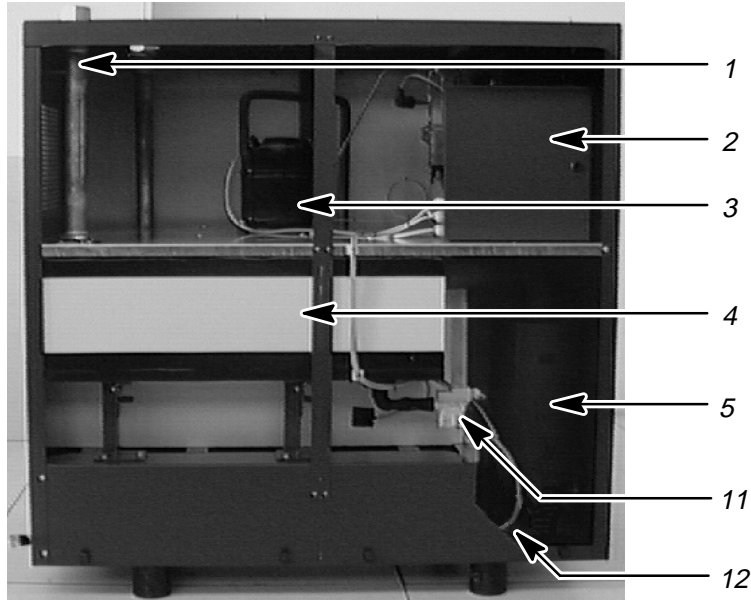

- |                                 |  |
|---------------------------------|--|
| 1 Compressed air outlet         | 8 Filter dryer (8)                       |
| 2 Control cubicle               | 9 Capillary tube (7)                     |
| 3 Refrigerant compressor (11)   | 10 Refrigerant liquefier (10)            |
| 4 Air to air heat exchanger (1) | 11 Condensate ECO-DRAIN (5)              |
| 5 Condensate separator (3)      | 12 Drain hose                            |
| 6 Compressed air inlet          | 13 Air to refrigerant heat exchanger (2) |
| 7 Safety pressure switch (9)    |  |

**5.5 Pipe and Instrument Flow Chart (P & I Flow Chart)**

(see following pages)

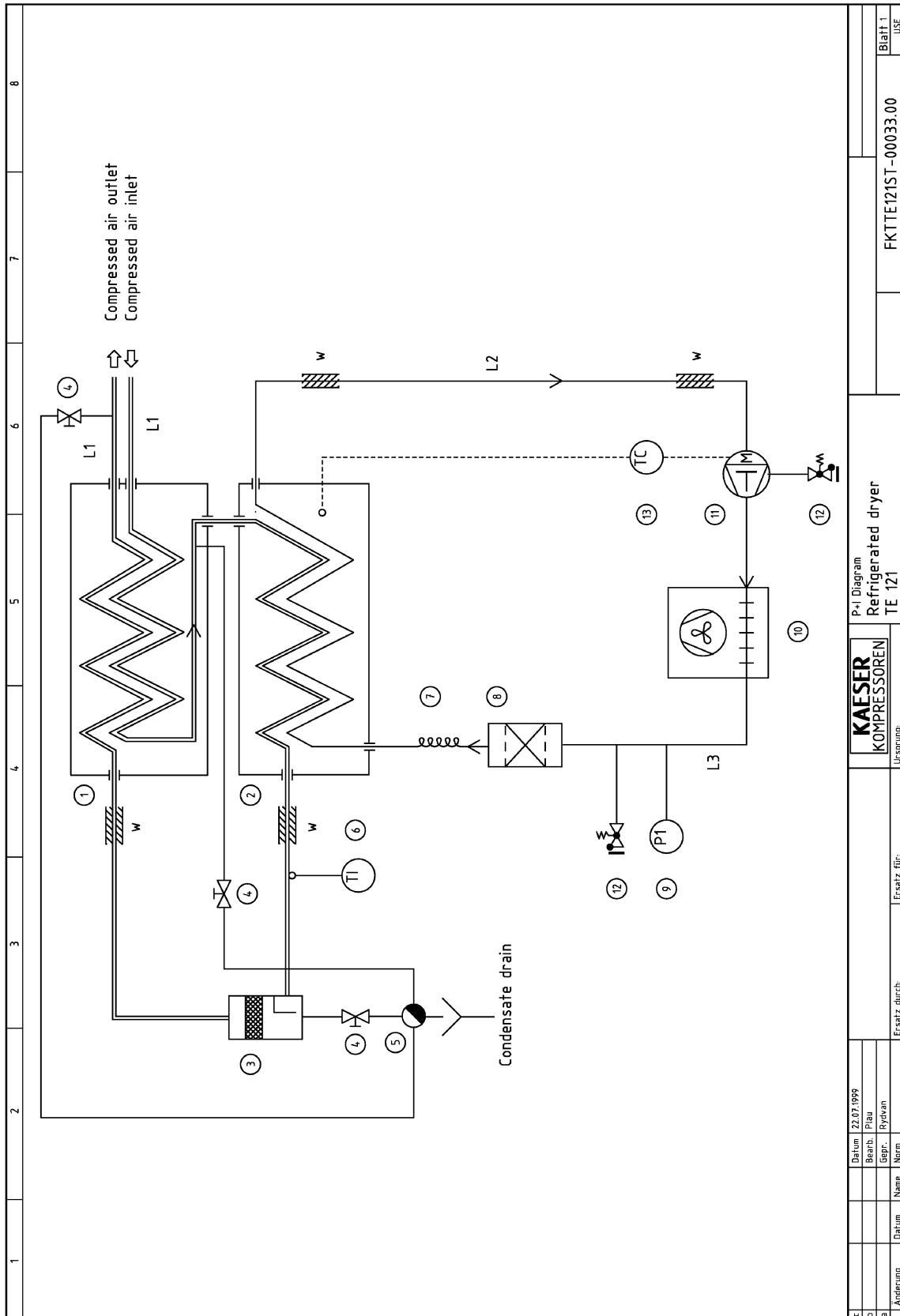

c	Datum	22.07.1999	P-I Diagram		FKTTE121ST-00033.00		Blatt 1
b	Bearb.	Flau	Refrigerated dryer				USE
a	GBPr.	Rytkov	TE 121				
Aenderung	Datum	Name	Ersatz für:		Ersatz durch:		Ursprung:
			KAESER		KAESER		
			KOMPRESSOREN		KOMPRESSOREN		

1	2	3	4	5	6	7	8																																				
1	Air/air heat exchanger				} heat insulated																																						
2	Air to refrigerant heat exchanger (Evaporator)																																										
3	Condensate separator																																										
4	Shut-off valve																																										
5	Condensate drain																																										
6	Pressure dew point indicator TI																																										
7	Capillary tube (Refrigerant injection)																																										
8	Filter dryer																																										
9	Safety pressure switch																																										
10	Refrigerant condenser (air cooled condenser)																																										
11	Refrigerant compressor (hermetic)																																										
12	Service connection (Schrader valve)																																										
13	Thermostat																																										
<b>Piping:</b>																																											
L1	CU-Pipe 54 x 2,0 DIN 1708																																										
L2	CU-Pipe 12 x 1,0 DIN 1708																																										
L3	CU-Pipe 8 x 1,0 DIN 1708																																										
w	heat insulated																																										
<table border="1"> <tr> <td>Änderung</td> <td>Datum</td> <td>Name</td> <td>Norm</td> </tr> <tr> <td>c</td> <td></td> <td></td> <td></td> </tr> <tr> <td>b</td> <td></td> <td></td> <td></td> </tr> <tr> <td>a</td> <td></td> <td></td> <td></td> </tr> </table>		Änderung	Datum	Name	Norm	c				b				a				<table border="1"> <tr> <td>Datum</td> <td>22.07.1999</td> </tr> <tr> <td>Bearb.</td> <td>Flau</td> </tr> <tr> <td>Gepr.</td> <td>Rydwan</td> </tr> </table>		Datum	22.07.1999	Bearb.	Flau	Gepr.	Rydwan	<table border="1"> <tr> <td>Ersatz durch:</td> <td>Ersatz für:</td> </tr> <tr> <td></td> <td>Ursprung:</td> </tr> </table>		Ersatz durch:	Ersatz für:		Ursprung:	<table border="1"> <tr> <td colspan="2"> <b>KAESER</b> KOMPRESSOREN         </td> </tr> <tr> <td colspan="2">           P-I Diagram legend            Refrigerated dryer            TE 121         </td> </tr> </table>		<b>KAESER</b> KOMPRESSOREN		P-I Diagram legend Refrigerated dryer TE 121		<table border="1"> <tr> <td colspan="2">FKTTE121ST-00033.00</td> </tr> <tr> <td>Blatt 2</td> <td>USE</td> </tr> </table>		FKTTE121ST-00033.00		Blatt 2	USE
Änderung	Datum	Name	Norm																																								
c																																											
b																																											
a																																											
Datum	22.07.1999																																										
Bearb.	Flau																																										
Gepr.	Rydwan																																										
Ersatz durch:	Ersatz für:																																										
	Ursprung:																																										
<b>KAESER</b> KOMPRESSOREN																																											
P-I Diagram legend Refrigerated dryer TE 121																																											
FKTTE121ST-00033.00																																											
Blatt 2	USE																																										

## 6 Installation

### 6.1 Installation Requirements

The refrigerated dryer must be installed in a dry and dust free space. To ensure adequate room for the maintenance of the refrigerated dryer, the minimum distances must be complied with (see following sketch).

Install the dryer on an even flat surface. Special foundations for the installation of the refrigerated dryer are not necessary.

See chapter 1.4 for the the ambient temperature and maximum height of the place of installation.

**Attention!**

To ensure adequate ventilation and air circulation, be sure to allow for the indicated minimum clearances at the cooling air inlet and exhaust.

The refrigerated dryer must not be installed in the air inlet and/or cooling air outlet area of a compressor package.

The compressed air to be dried and the ambient air in the compressor space may not contain any acid-forming or other aggressive materials.

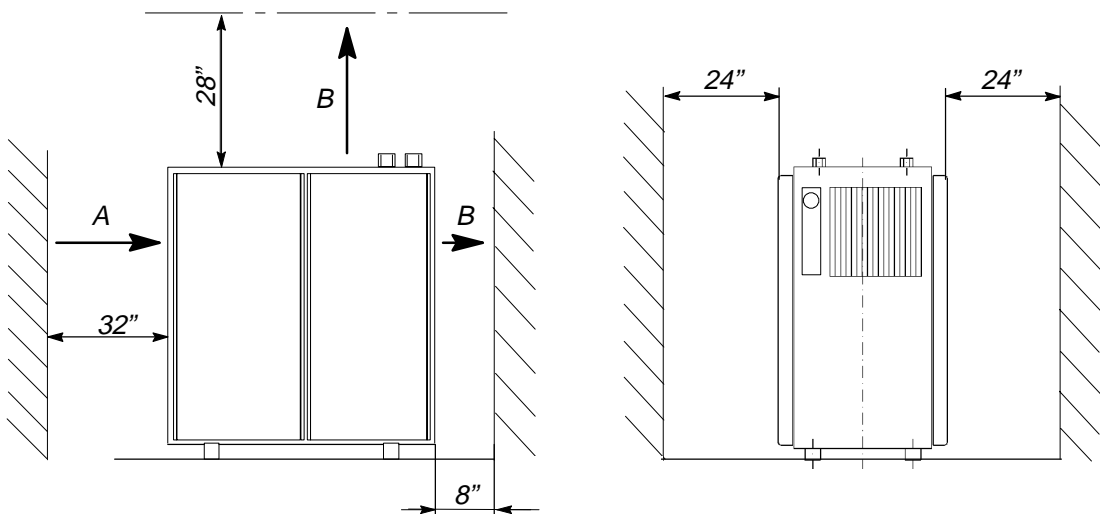

*Measurements shown are minimum recommendations*

*A Cooling air inlet*

*B Cooling air outlet*

**Attention!**

Installing of inlet and/or exhaust air ducting without prior written approval from of KAESER COMPRESSORS Inc. is not permitted.

## 6.2 Compressed Air Connection

**Attention!**

Use flexible connecting pipes at the compressed air inlet and discharge to ensure vibration isolation, prevent strain on piping connections and allow easy installation.  
To avoid damage, do not overtighten the compressed air connections.

The refrigeration dryer is piped ready for operation.

**Shut-off valves:**

All power driven systems must be equipped with a main stop system for all forms of energy feed, the operation of which determines the start and stop of the energy supply to the system.

The compressed air inlet and outlet pipework must be provided with shut off arrangements (e.g. ball valves).

**Bypass:**

The compressed air inlet and outlet should be fitted with a bypass.

See diagram in chapter 1.10 for details of the bypass.

**Installation notes:**

Identification numbers in ( ) correspond to the diagram of the bypass in chapter 1.10.

- ☞ Screw the threaded part of the union fitting (60) (with sealing tape) into the corresponding connection for the compressed air inlet or outlet.
- ☞ Insert the flat gasket (70) and fit the bypass by screwing down and tightening the union nut of the fitting (60).
- ☞ Check the fittings for leakages.

See chapter 1.5 for the dimensions of the connector fittings.

## 6.3 Condensate Drain Connection

A hose connection is provided for drainage of the condensate. See chapter 1.5 for the dimensions.

**Attention!**

Use caution when attaching the condensation drain line to ensure that the condensate flow is not obstructed.



The condensate must be drained and collected in a suitable container. It must be disposed of in accordance with federal and local environmental codes.

## 6.4 Electrical Connection



The main power supply and overcurrent protection must be installed by a qualified electrician in accordance with NEC, OSHA and any applicable local codes.

For fuse and wire recommendations, see chapter 1.6.

The refrigerated dryer is delivered completely wired, ready for connection to the power supply. This connection must be made as detailed in the electrical diagram (see chapter 11.1). See the dimensional diagram (see chapter 1.9) for the position and size of the cable entry into the refrigerated dryer.

**Attention!**

Maximum dual element time–delay fuses are selected according to 1996 N.E.C. Article 240–6, 430–52 and Tables 430–148 & 150.

Select multi–strand copper core wire at 40 °C ambient temperature according to 1996 N.E.C. 110–14(c), 220–3, 310–15, Table 310–16, 430–6, 430–22 and Tables 430–148 & 150.

Wire temperature rating:

1.25 x FLA (see chapter 1.6)	wire temperature rating	correction factor for 40 °C
≤ 100A	60 °C	0.82
> 100A	75 °C	0.88

## 6.5 Voltless Contacts

The refrigerated dryer is provided with the following volt–free alarm contacts for connection to an external alarm reporting system:

- Message: "Control voltage ON"
- Message: "High pressure dewpoint "
- Message: "Malfunction condensate drain"

## 7 Preparation For Initial Start Up

### 7.1 Points to be Observed before Start Up

Every refrigerated dryer is tested in the factory and carefully checked before shipment. The test run confirms that the refrigerated dryer conforms to the manufacturer's specifications and operates as designed. However, independent of the checks made at the factory, the refrigerated dryer could be damaged during transport. For this reason, we recommend that the refrigerated dryer be examined for any damage. Inspect the refrigerated dryer carefully during the first hours of operation for any possible malfunction.

**Attention!**

**The internal components of the refrigerated dryer are factory adjusted for correct operation. Adjustments may not be made to these components without prior written consultation with KAESER Compressors Inc.**

### 7.2 Points to be Observed before Switching On:



**NON-OBSERVANCE OF THESE OR OTHER REFERENCES (WARNING; ATTENTION) CAN LEAD TO ACCIDENTS CAUSING INJURY TO PERSONNEL OR DAMAGE TO EQUIPMENT.**

**It is forbidden to operate the refrigeration dryer with the panelling removed because of the danger of injury to personnel.**

- ☞ Remove all packaging materials, tools and transport securing devices on and in the refrigerated dryer.
- It is expected that the user employs safe working techniques when operating the refrigeration dryer and that all valid operating and safety provisions are followed.
- The operator of this refrigerated dryer unit is responsible for its safe working condition.
- The air in the compressor space and the compressed air to be dried may not contain any acid-forming or other aggressive matter.
- Do not connect the refrigerated dryer to a supply voltage different to that shown on the nameplate.
- Install the refrigerated dryer in a space that is not subject to freezing conditions. See chapter 1.4 for the minimum ambient temperature.
- Wait for the refrigerated dryer to warm up to the ambient temperature before putting into operation.



**Carry out the following work only when the power supply is removed from the refrigerated dryer:**

**Check all screws on the electrical connections for tightness and tighten if necessary (carry out this check again after 50 operating hours).**

### 7.3 Ready for Operation

**Attention!** Do not start the refrigerated dryer until completing the following:

- The refrigerated dryer is installed according to the conditions stated in chapter 6.
- All electrical connections, air piping and condensate lines are correctly connected and properly tightened.
- The shut-off valves in the compressed air inlet and outlet lines are closed.
- The condensate drainage line is free of obstructions.
- The refrigerated dryer is supplied with the correct voltage supply.
- The by-pass in the compressed air line between input and output lines is closed.

**Attention!** Start the refrigerated dryer for approximately 15 minutes before opening the shut-off valves in the compressed air inlet and outlet lines.



## 8 Operation

During operation of the refrigerated dryer, condensate is separated from the compressed air.



**The condensate must be drained and collected in a suitable container. It must be disposed of according to Federal and local environmental codes.**

☞ Collect the accumulated condensate in a container and dispose of properly.

### 8.1 Instrument Panel

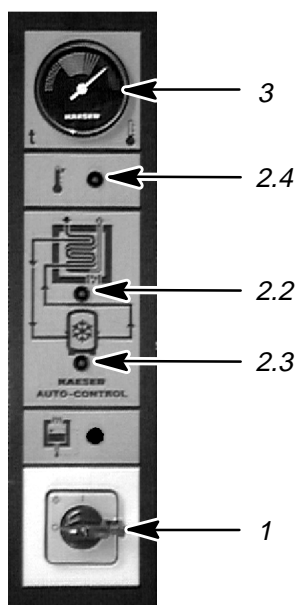

- 1 Main switch
- 2 KAESER-AUTO-CONTROL:
  - 2.2 "Control Voltage ON" and thermal mass effective
  - 2.3 "Refrigerant Compressor ON" indication
  - 2.4 "High Dewpoint" alarm
- 3 Pressure dewpoint gauge

Explanation of the colored segment scale of the pressure dew point indication:  
(suction pressure gauge)

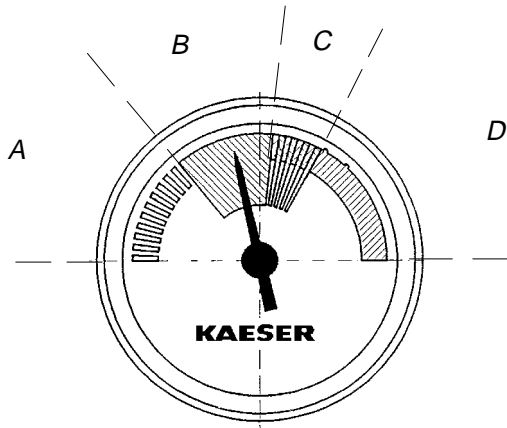

- **A**

**Blue–white range (low suction pressure) results in too low a pressure dewpoint due to:**

- Evaporator temperature too low (evaporator freeze–up)
- Dryer too large or very low air demand. Refer to chapter 1.4

- **B**

**Green range (normal suction pressure) results in a normal pressure dew point.**

- **C**

**Green–red range (elevated suction pressure) results in increased pressure dew point to:**

- High ambient temperature

- **D**

**Red range (high suction pressure) results in too high a pressure dew point due to:**

- Fault, see chapter 8.4.3 for help

## 8.2 Starting the Refrigerated Dryer

**Attention!**

Switch on the refrigerated dryer only if the conditions in chapter 7.3 “Ready for Operation” are fulfilled.

- ☞ Check the refrigerated dryer according to chapter 7.3.
- ☞ Remove the padlock provided for protection against “inadvertent switch–on” of switch (1).
- ☞ Rotate the switch (1) to “I” (ON).

The refrigeration dryer is now in operation, the control lamp (3) illuminates indicating power on.

Depending on the temperature in the air to refrigerant heat exchanger, the refrigerant compressor switches on after the refrigeration dryer is switched on. Simultaneously the control lamp (2) “Refrigerant Compressor ON” illuminates.



If the control lamp (2) does not extinguish after approximately 15 minutes then a fault is apparent (see chapter 8.4.3).

**Attention!**

Do not open the compressed air shut-off devices (inlet/outlet) until the control lamp (2) is extinguished.

- ☞ Open the shut-off valve of the compressed air inlet slowly (admission of the compressed air).
- ☞ Open the shut-off valve of the compressed air outlet slowly.

The compressed air system is now connected to the refrigerated dryer.

**Attention!**

Press RESET if the safety pressure switch has shut down the refrigerated dryer.

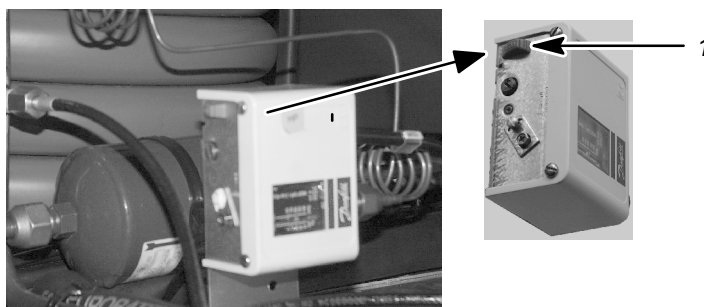
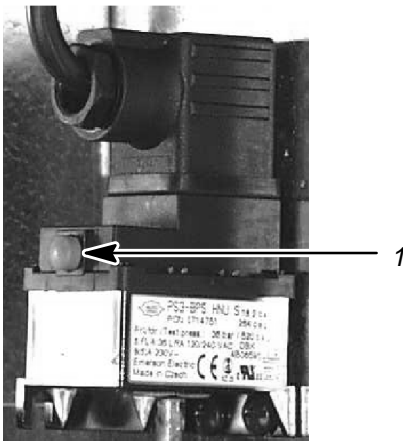

1 RESET

### 8.3 Stopping the Refrigerated Dryer

- ☞ Close the compressed air shut-off valves (inlet and outlet).

**Attention!**

The main switch (1) can be secured in the "0" position against inadvertent switch-on by a small padlock.

- ☞ Turn switch (1) to "0" (OFF).

The refrigerated dryer is switched off and the control lamp is off.

## 8.4 Trouble shooting



**The local safety regulations (see chapter 2) and the regulations detailed in the "Safety" chapter must be complied with during trouble-shooting.**

See chapter 7.3 and chapter 8.2. when starting the refrigerated dryer after the malfunction has been corrected.

### 8.4.1 Water in the compressed air system

#### Possible cause:

Moisture deposits in the compressed air pipe work that were formed before the dryer was started.

Bypass opened.

Compressed air inlet and outlet swapped.

The condensate is not drained out of the system.

#### Remedy:

Blow out the compressed air pipe work with dry air until no more moisture condenses.

Close the bypass.

Check the compressed air connections using the dimensional diagram.

Check the ECO-DRAIN (see chapter 9.2.4); Contact the authorized KAESER distributor.

### 8.4.2 High pressure losses via the refrigerated dryer

#### Possible cause:

Refrigerated dryer iced up on the air side.

#### Remedy:

Switch off the dryer until the air system has thawed. If the system ices up again after starting again, refer to authorized KAESER distributor.

### 8.4.3 Pressure dew point too high

#### Possible fault:

Ambient temperature too high.

Compressed air inlet temperature is too high.

Flow volume too high.

Low refrigerant.

Defective refrigerant compressor.

Defective condenser fan motor.

High contamination component in the compressed air causing scale in the compressed air system.

Condenser surface (refrigerant liquefier) contaminated.

#### Remedy:

Check the technical data, see chapter 1.2.

Check the technical data, see chapter 1.2.

Check the technical data, see chapter 1.2.

Refer to authorized KAESER distributor.

Refer to authorized KAESER distributor.

Refer to authorized KAESER distributor.

Clean the compressed air system.

See maintenance instructions chapter 9.2.2.

**8.4.4 High compressed air losses****Possible fault:**

Constant loss of pressure via the condensate drain.

**Remedy:**

Clean the ECO–DRAIN (see chapter 9.2.5).

**8.4.5 Red LED on the ECO–DRAIN housing flashes****Possible cause:**

Condensate not draining.

**Remedy:**

Check the ECO–DRAIN (see chapter 9.2.4); contact authorized KAESER distributor.

**8.4.6 The safety pressure switch shuts down the refrigerated dryer****Possible fault:**

Ambient temperature too high.

**Remedy:**

Check the technical data, see chapter 1.2.

Condenser surface (refrigerant liquefier) contaminated.

See maintenance instructions chapter 9.2.2.

Defective condenser fan motor.

Refer to authorized KAESER distributor.

## 9 Maintenance

### 9.1 Maintenance Instructions:



Before starting work, follow the procedure below to ensure the unit is not started or energized while maintenance work is being performed:

Work on the electrical equipment of the refrigerated dryer may only be carried out by a qualified electrician or trained personnel under the supervision of a qualified electrician according to local codes.

Lock the main disconnect in the "off" position in accordance with applicable lock out/tag out procedures (example: OSHA CFR 29 § 1910.147) to ensure the dryer does not restart.

Before starting work, carry out the following procedure to prevent inadvertent application of power to the refrigerated dryer:

- ☞ turn switch (1) to " 0 ".
- ☞ lock out the switch (1) using a suitable padlock.

Before restarting the refrigerated dryer, ensure that:

- no maintenance personnel are working on the refrigerated dryer.
- all tools are removed from the refrigerated dryer.
- all guard and cover panels are properly installed and secured.

See chapter 7.3 and 8.2 for starting the refrigeration.

### 9.2 Regular Maintenance

Period	Work to be done	see chapter
Daily	Check the condensate outlet	9.2.3
50 hours after initial start	Clean the ECO-DRAIN	9.2.5
Every month	Check ECO-DRAIN for proper operation	9.2.4
	Clean the surface of the condenser	9.2.2
If necessary	Clean the ECO-DRAIN diaphragm valve	9.2.5
Every three month	General checks	9.2.1
Every year	Clean the ECO-DRAIN	9.2.5

The maintenance periods are recommended periods and may need to be adjusted based on installation and service conditions.

### 9.2.1 General checks

- ☞ Inspect the electrical components of the refrigerated dryer every two to three months. Correct any malfunctioning or worn components, such as loose connections or overheated cable immediately!



**Escaping compressed air and/or refrigerant can cause injury to personnel and lead to damage to the dryer.**

- ☞ Check all pipework, hoses and screwed fittings for leakage every two to three months and carry out a visual check for any external damage. Correct any faults immediately!



**The refrigerant contained in the refrigerating system may not be vented to the open air. Always use a refrigerant recovery system when working on the refrigerant circulation. Dispose of unusable refrigerant according to environmental regulations!**

### 9.2.2 Cleaning the condenser

Clean the condenser every month.

- ☞ Stop the refrigerated dryer by turning the switch (1) to the “off” position.
- ☞ Lock the switch (1) with a suitable padlock to prevent unauthorized switch-on.
- ☞ Clean the cooling fins of the refrigerant liquefier by blowing compressed air from the outside to the inside.

See chapter 8.2 to start the refrigerated dryer.

### 9.2.3 Check the condensate outlet daily as follows:

**Attention!**

**If neither condensate nor compressed air exits, clean the ECO-DRAIN. (See chapter 9.2.5)**

- ☞ Verify that condensate exits from the hose of the condensate drain outlet when the drain opens (the LED extinguishes for a short period).

### 9.2.4 Functional check of the ECO-DRAIN

Check monthly that the ECO-DRAIN functions correctly by pressing the TEST button on the cover. Observe the instructions in chapter 11.3 of the installation and operating manual for the ECO-DRAIN.

For possible malfunction cause, remedy and indication of operation status see service manual for ECO-DRAIN in chapter 11.3.

### 9.2.5 Cleaning the ECO-DRAIN

Clean the condensate drain monthly, or more frequently depending on the degree of contamination of the compressed air.

It is recommended that the ECO-DRAIN is cleaned after the first 50 hours of service.

Maintenance work on the ECO-DRAIN is only possible with the ECO-DRAIN removed.

#### **Initial work:**

- ☞ Stop the refrigerated dryer by turning the switch (1) to the “off” position.
- ☞ Lock the switch (1) with a suitable padlock to prevent unauthorized switch-on.

- ☞ Unscrew the two screws holding the left-hand side cover and remove the cover.



**Before removing up the ECO-DRAIN it must be shut off from the compressed air.**

- ☞ Close the shut-off valve in the air line to the ECO-DRAIN.

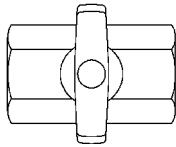

*Shut-off valve  
closed*

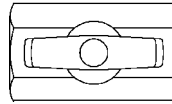

*Shut-off valve  
opened*

#### **Removing the ECO-DRAIN:**

- ☞ Depressurize the ECO-DRAIN by pressing the TEST pushbutton.
- ☞ Carefully remove the insulation on the ECO-DRAIN. Do not damage, the insulation will be needed again!).
- ☞ Unscrew all fittings for the feed lines on the ECO-DRAIN.
- ☞ Unscrew the venting line and condensate drain hose.
- ☞ Unscrew the fixing screws holding the ECO-DRAIN to the angle bracket.
- ☞ Take out the ECO-DRAIN.

**Attention!**

**The ECO-DRAIN is still connected to the power supply cable.**



## 10 Spare Parts and After Sales Service

Provide the following details for all queries and spare parts orders:  
(see also the name plate)

Refrigerated dryer, model: .....

Serial number: .....

Part name: .....

Part order number: .....

Always provide the date of initial start up when making claims under warranty!

### Name plate:

	Typ./Model./Type/Tipo/ Modelo/Type
	Artikel-Nr./Part-No./ Référéncja/Codice/ Artículo-N.º / Artikel-Nr.
	Baujahr/Year/Année de fabrication/Anno/Año de construcción/Bouwjaar
	Serien-Nr./Serial No./ No. de série/N. di Matricola/ Nº de Matricula/Serienr.
Kältesystem/Refrigerant system/Système frigorifique/ Circuito refrigerante/Circuito frigorífico/Koelstelsysteem	Kältemittel/Refrigerant/Système frigori- lique/Agente refrigerante/ Agente frigorífico/Koelmiddel
	Füllgewicht/Charge/Charge/ Carga/Peso de relleno/ Vulgewicht <i>lb.</i>
	Betriebsdruck HD/Working pressure HP/ Pression de fonctionnement HP/Pressione AP/ Presión de trabajo AP/Bedrijfsdruk HD <i>psig</i>
Luftsysteem/Air system/ Système d'air/Circuito aria/ Circuito de aire/Luftsysteem	Betriebsdruck/Working pressure/Pression de fonctionnement/Pressione di esercizio/ Presión de trabajo/Bedrijfsdruk <i>psig</i>
E-Anschluss/Electrical supply/ Alimentation électrique/ Alimentazione elettrica/ Alimentación eléctrica/ Elektrische aansluiting	Nennspannung/Rated voltage/Tension nominale/tensione nominale/ Tensión nominal/Nominale spanning <i>v</i> <input type="checkbox"/> 1ph <input type="checkbox"/> 3ph
	Frequenz/Frequency/ Fréquence/Frequenza/ Frecuencia/Frequentie <i>Hz</i>
	Nennstrom/Rated current/Courant nominal/Corrente nominale/Corriente nominal/Nominale stroom <i>A</i>
Umgebungstemperatur/Ambient temperature/ Température ambiante/temperatura ambiente/tem- peratura ambiente/Omgevingstemperatuur <i>min. 40 °F / max. 110 °F</i>	
Dichtheit geprüft/Leakproof/Etanchéité testée/Ermetico/Hermético/Dichtheid getest <input type="checkbox"/>	

**11 Appendix**

**11.1 Wiring Diagram**

1	2	3	4	5	6	7	8	
<p>Wiring Diagram</p> <p>air dryer TE 91/121/141</p> <p>460V 3Ø 60CY</p>								
<p>manufacturer: KAESER COMPRESSORS</p> <p>96450 COBURG</p> <p>GERMANY</p>								
c		Datum	02.07.2001	USE	cover page			=
b		Bearb.	Sittler		air dryer TE 91/121/141			+
a		Gepr.	Gegner		DTE-U0909.00			
A   Änderung		Datum	Name	Norm	Ursprung: UTEU0908			Blatt 1
					Ersatz durch:			Bl.
					Ersatz für:			

Lfd. Nr. No.	Benennung Name	Zeichnungsnummer (Kunde) Drawing No. (customer)	Zeichnungsnummer (Hersteller) Drawing No. (manufacturer)	Blatt Page	Anlagenkennzeichen Unit designation
1	cover page		DTE-U0909.00	1	
2	list of contents		ZTE-U0909.00	1	
3	wiring diagram power unit/power supply		STE-U0909.00	1	
4	wiring diagram control unit		STE-U0909.00	2	
5	wiring diagram control unit		STE-U0909.00	3	
6	wiring diagram Volt-free contacts		STE-U0909.00	4	
7	component legend		STE-U0909.00	5	
8	electrical component parts list controller		GTE-U0909.00	1	
9	terminal connection terminal strip -X1		KTE-U0909.00	1	
10	lay-out control panel		ATE-U0909.00	1	

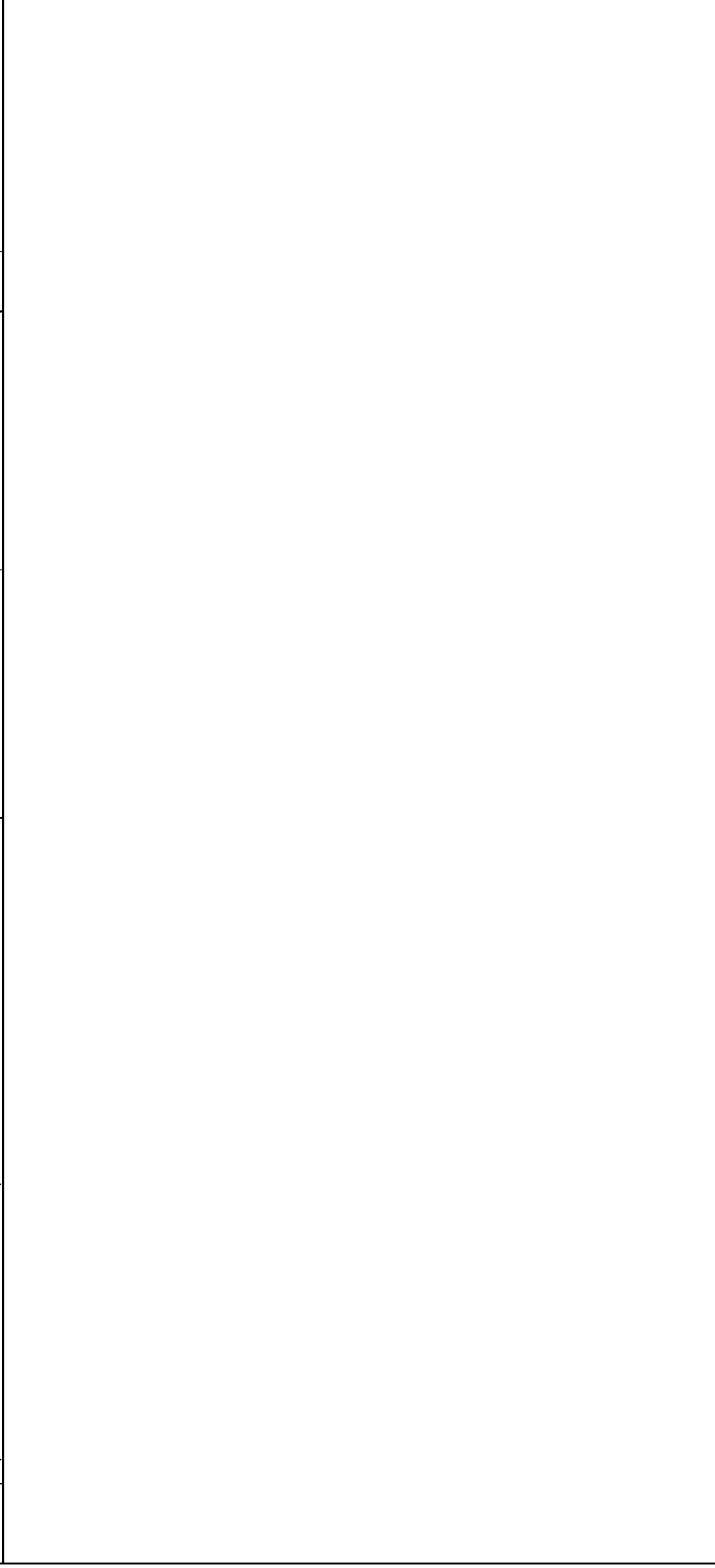

Änderung		Datum	Name	Norm	Ersatz durch:	Ersatz für:	Ursprung:	
c			Datum 02.07.2001					
b			Bearb. Sittler					
a			Gepr. Egner					
list of contents air dryer TE 91/121/141							ZTE-U0909.00	
KAESE KOMPRESSOREN								
=								
+								
Blatt 1								
Bl.								

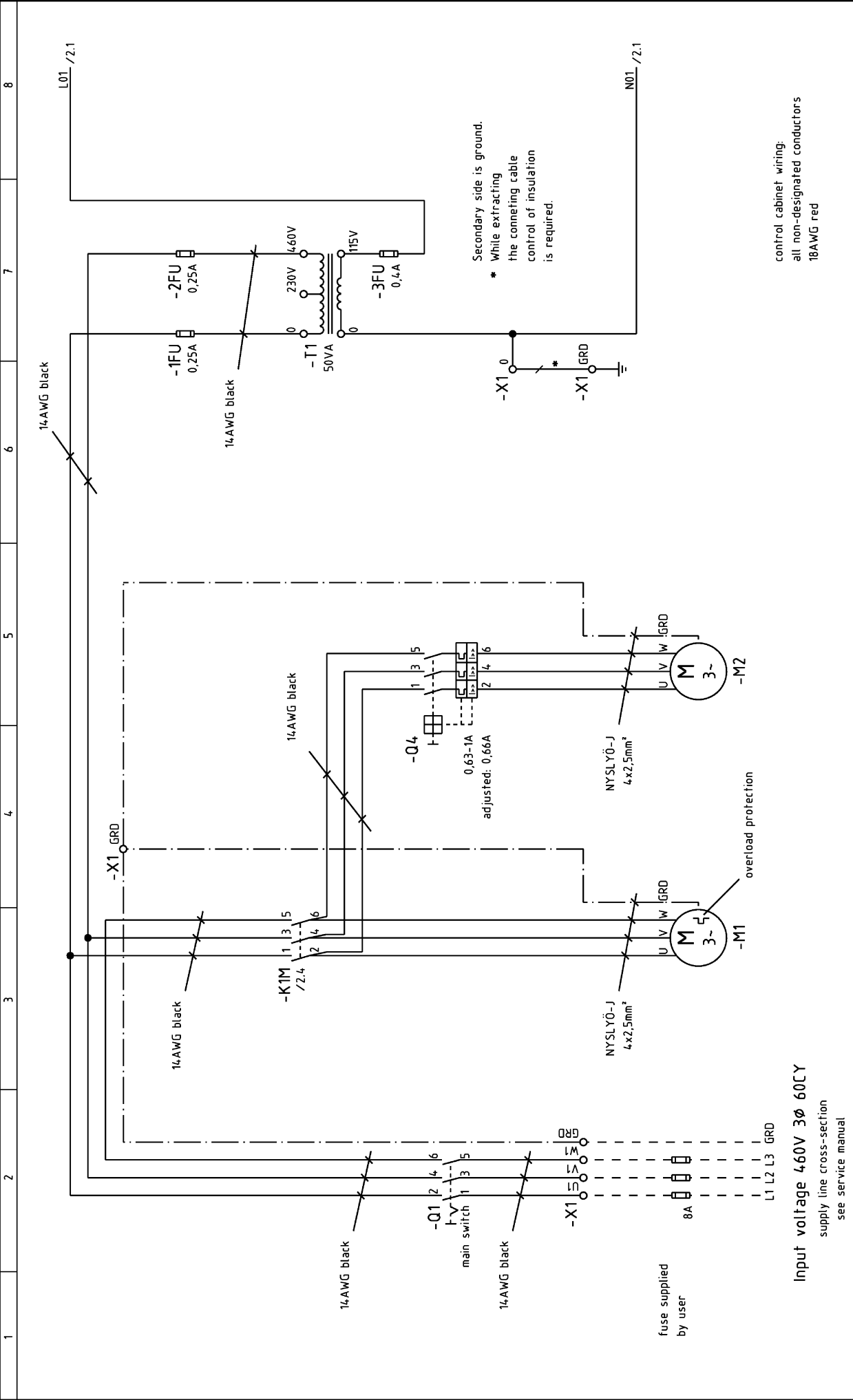

Input voltage 460V 3Ø 60CY  
supply line cross-section  
see service manual

Function:		compressor motor with overload protection		vent motor		115V/1-/60CY	
Group of function:		power unit		control voltage tapping			
c	Datum	02.07.2001					
b	Bearb.	Sitter					
a	Gepr.	Egner					
D	Änderung	Datum	Name	Ersatz durch:	Ursprung: UTEU0908	wiring diagram air dryer TE 91/121/141 power unit/power supply	=
						STE-U0909.00	
						Blatt 1	
						Bl.	

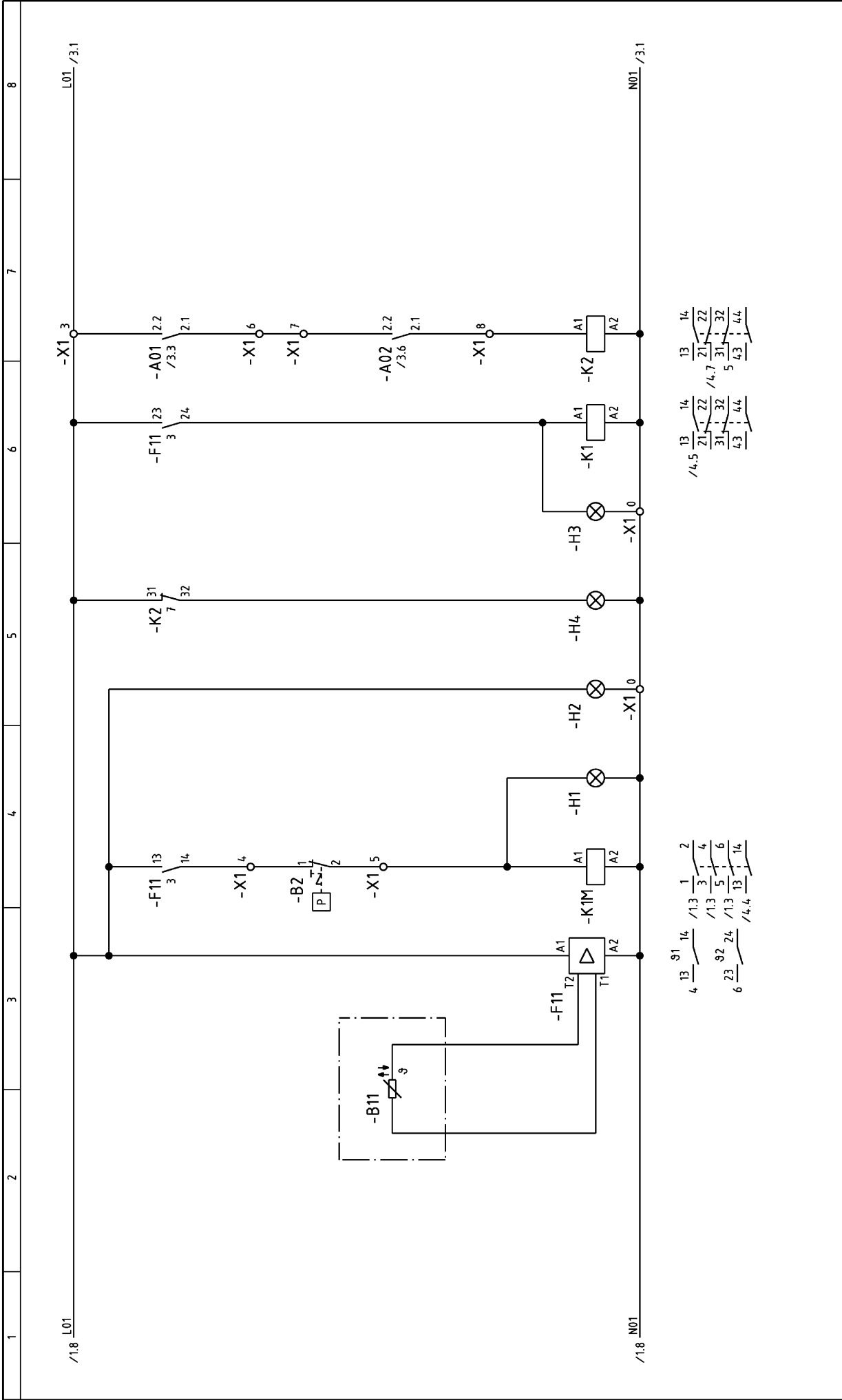

Function:		control voltage ON		FAILURE - temperature	
Function:		motor running		FAILURE - condensate drain	
Group of function:		NTC-temperature control		control unit	
c	Datum	02.07.2001		=	
b	Bearb.	Sittler		+	
a	Gepr.	Egner			
D	Änderung	Datum	Name	Ersatz durch:	
				KAESER	
				KOMPRESSOREN	
				wiring diagram	
				air dryer TE 91/121/141	
				control unit	
				STE-U0909.00	
				Blatt 2	
				Bl.	

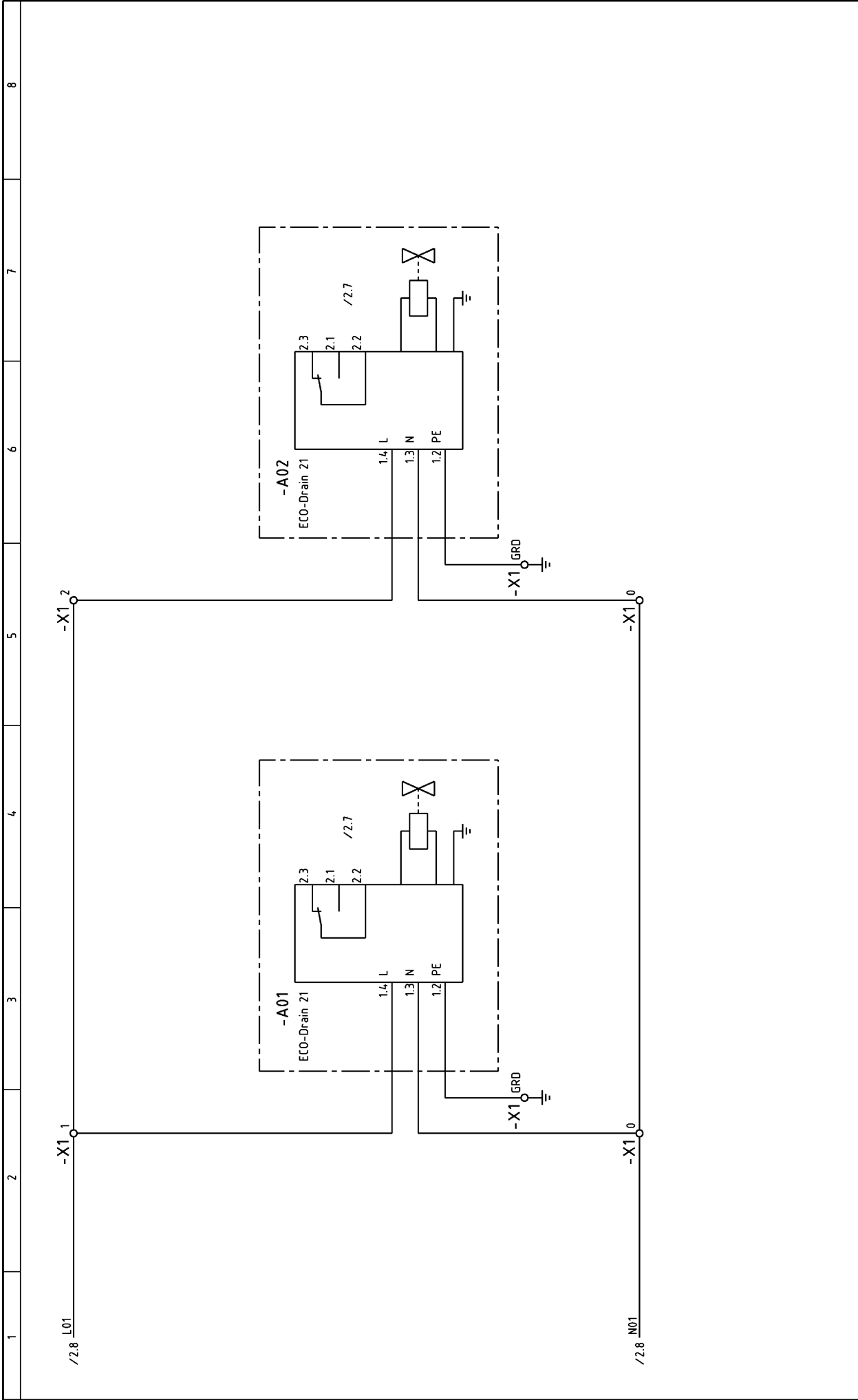

Function:		automatic condensate drain	
Group of function:		wiring diagram	
c	Datum	02.07.2001	=
b	Bearb.	Sittler	*
a	Gepr.	Gegner	
D	Änderung	Datum	Name
Ersatz durch:		Ersatz für:	
KAESEKOMPRESSOREN		KAESER	
TE 91/121/141		air dryer	
STE-U0909.00		control unit	
Blatt 3		Bl.	

### User's connection

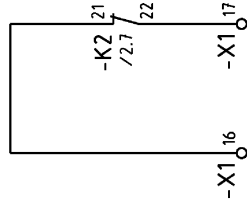
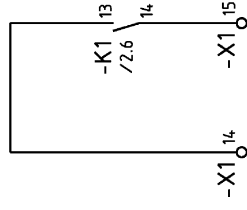
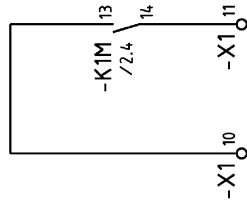

all non-designated conductors,  
16AWG yellow

Function:		high dew point		FAILURE condensate drain	
Group of function:		Volt-free contacts		motor running	
		Volt-free contacts			
		wiring diagram			
		air dryer TE 91/121/141			
		Volt-free contacts		STE-U0909.00	
		KAESE			
		KOMPRESSOREN			
		Ursprung: UTEU0908			
		Ersatz durch:			
		Name			
		Datum			
		Norm			
		Gepr.			
		Sitzer			
		Datum			
		02.07.2001			
		Bearb.			
		Egner			
		Blatt 4			
		Bl.			



1	2	3	4	5	6	7	8	
<p>-A01,-A02 automatic condensate drain</p> <p>-B2 safety air pressure switch</p> <p>-B11 NTC-temperature probe</p> <p>-1FU,-2FU primary control fuse</p> <p>-3FU secondary control fuse</p> <p>-Q4 circuit breaker</p> <p>-F11 NTC-thermostat</p> <p>-H1,-H2,-H3,-H4 LED indicator</p> <p>-K1,-K2 control relay</p> <p>-K1M motor starter</p> <p>-M1 compressor motor with overload protection</p> <p>-M2 vent motor</p> <p>-Q1 main switch</p> <p>-T1 control transformer</p> <p>-X1 terminal strip</p>								
c	Datum	02.07.2001						component legend
b	Bearb.	Sittler						air dryer TE 91/121/141
a	Gepr.	Gegner						STE-U0909.00
E	Änderung	Datum	Name	Ersatz durch:		Ursprung: UTEU0908		
							=	
							+	
							Blatt 5	
							Bl.	





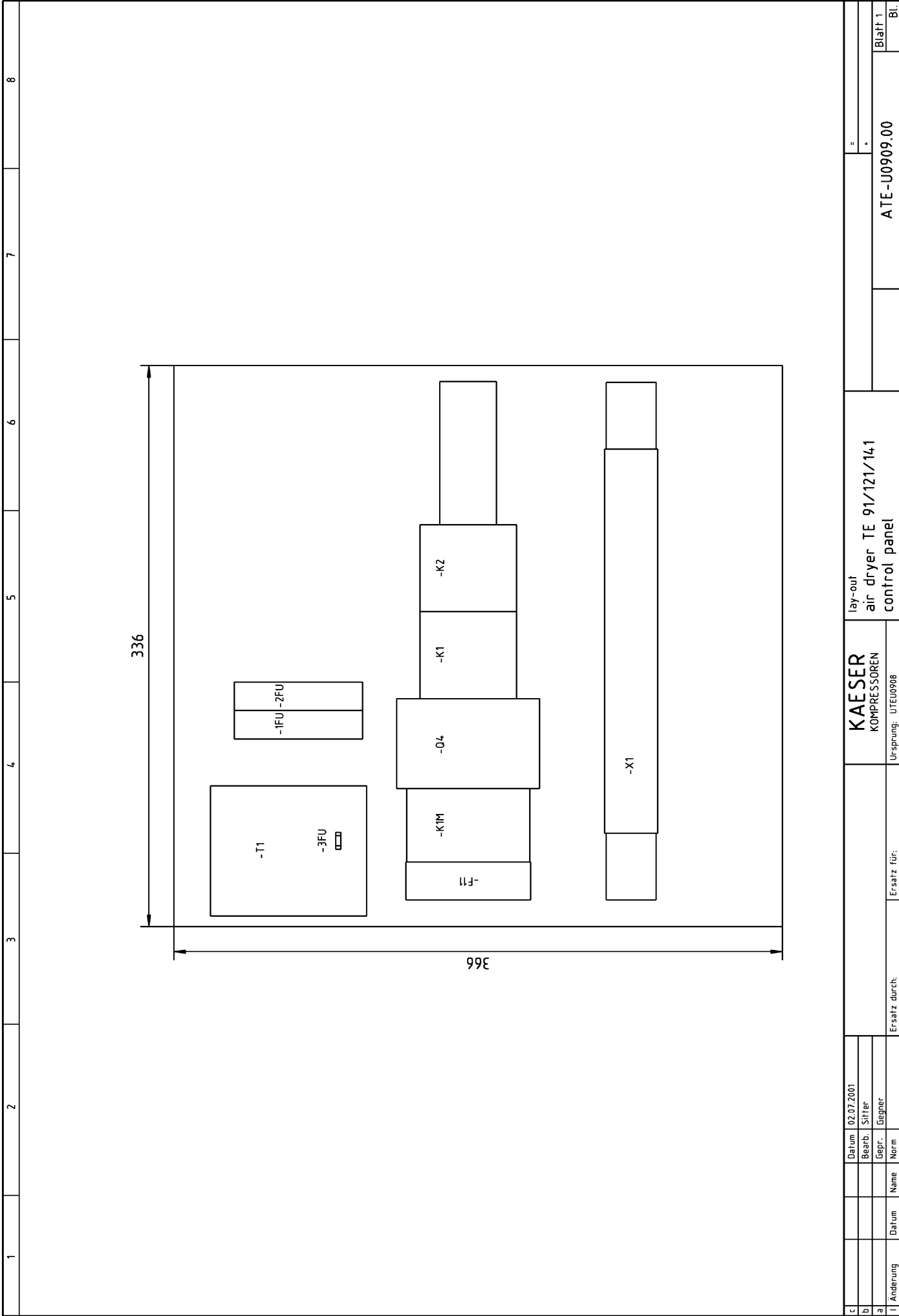

c	Datum	02.07.2001	Ersatz durch:	Ersatz für:	KAESE KOMPRESSOREN	lay-out air dryer TE 91/121/141 control panel	ATE-U0909.00	=
	Bearb.	Sittler						
a	Gepr.	Gegner	Blatt 1					
l	Änderung	Name	Norm	Bl.				

**11.2 Maintenance Schedule**

<b>Refrigerated dryer, model:</b>			
<b>Serial number:</b>			
Date	Description of work	Operating hours	Signature

11.3 Installation and Service Manual for ECO–DRAIN

# Eco-Drain



## Instruction manual



**Data/Notes • Características/Indicaciones  
Characteristiques/Avis • Dados/Indicações**



**IP 65**

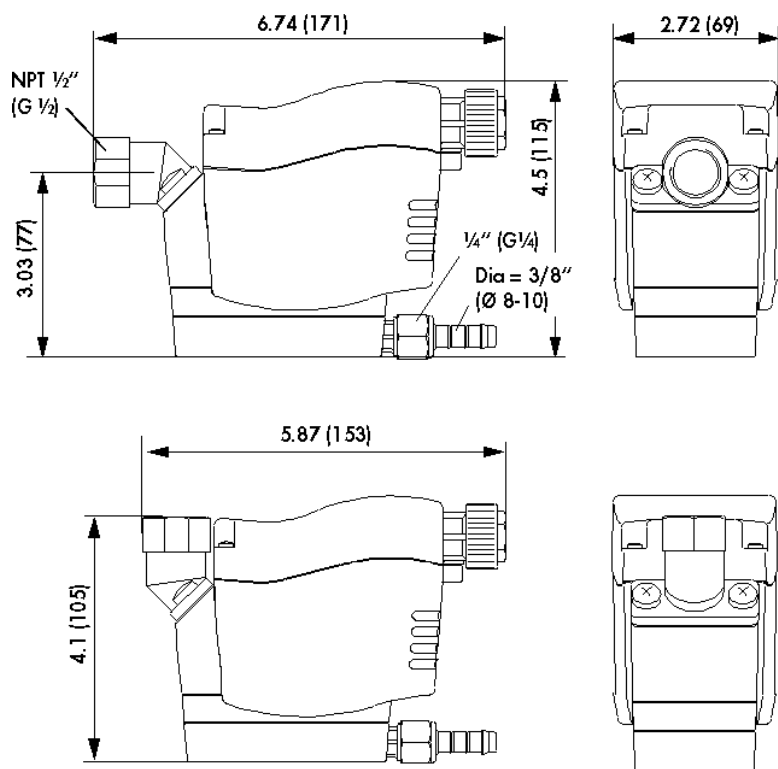

min/max temperature Temperatura mín./máx. Température min/max Temperatura mín./máx.	+34 ... +140 °F (+1 ... +60 °C)
Condensate feed Entrada condensado Entrée du condensat Entrada de condensado	1/2" NPT (G1/2)
Condensate discharge Salida condensado Sortie du condensat Saída de condensado	1/4" dia = 3/8" (1/4", Ø 8-10 mm)

peak compressor performance Caudal del compresor máx. Capacité maximale du compresseur Capacidade máxima do compressor	180 scfm (5 m <sup>3</sup> /min)
peak refrigeration dryer performance (only with pre-separation) Caudal del secador frigorífico máx. Capacité maximale du sécheur frigo (seules avec pré-separation) Capacidade máxima do secador frigorífico	360 scfm (10 m <sup>3</sup> /min)
peak filter performance (behind dryer) Caudal del filtro máx. (derriere sécheur) Capacité maximale filtre Capacidade máxima do filtro	1800 scfm (50 m <sup>3</sup> /min)
operating pressure, min/max Presión de servicio mín./máx. Pression de service min/max Pressão de serviço mín./máx.	12 ... 230 psig (0,8 ... 16 bar)
weight (empty) Peso (vacío) Poids (à vide) Peso (vazio)	1.5 lbs (0,7 kg)
condensate Condensado Condensat Condensado	oil-contaminated + oil-free oleoso + exento de aceite huileux Aluminio superficialmente com óleo + isento de óleo
housing Carcasa Boîtier Caixa	plastic, glass fiber Plástico con fibra de vidrio Matière plastique renforcée par fibres de verre Material plástico, reforçado por fibra de vidro



english	español	français	português
<p><b>SAFETY RULES</b></p> <p><b>1. Do not exceed max. operating pressure (see type plate)!</b> <b>NOTE:</b> Maintenance work must only be carried out when the device is not under pressure!</p> <p><b>2. Only use pressure-proof installation material!</b> The feed line (½") must be firmly fixed. Discharge line: short pressure hose to pressure-proof pipe. Please ensure that condensate cannot squirt onto persons or objects.</p> <p><b>3. If conical connectors are used on the inlet side, avoid excessive tightening of the connectors.</b></p> <p><b>4. For locking or holding in position during installation, use wrench area at inflow point!</b></p> <p><b>5. The electrical installation must be carried out in compliance with the valid regulations!</b> <b>NOTE:</b> Maintenance work is only allowed when the device is in a de-energized condition! Electrical work must always be performed by a qualified electrician.</p> <p><b>6. Do not operate the device when there is a danger of frost.</b></p> <p><b>7. The ECO-DRAIN condensate drain will only function when voltage is being applied to the device.</b></p> <p><b>8. Do not use the test button for continuous draining.</b></p> <p><b>9. Do not use the ECO-DRAIN device in hazardous areas (with potentially explosive atmospheres).</b></p> <p><b>10. Only employ original spare parts, otherwise the guarantee will no longer be valid.</b></p>	<p><b>INDICACIONES DE SEGURIDAD</b></p> <p><b>1. No sobrepase la presión máxima. (ver etiqueta de identificación)</b> <b>¡Atención!</b> Realice los trabajos de mantenimiento sólo si el aparato se encuentra sin presión.</p> <p><b>2. Utilice solamente los accesorios y la tubería flexible autorizados para la presión conectada.</b> La tubería de la entrada de los condensados (½") tiene que estar bien fijada. Salida de condensado: Un tubo flexible resistente a la presión unido a un tubo fijo resistente a la presión. Evite que personas o objetos pueden ser alcanzadas por el condensado.</p> <p><b>3. No utilice racores cónicos para la conexión con la entrada.</b></p> <p><b>4. Para el aguante o el giro durante la instalación utilice el área de la entrada de los condensados preparada para acoger una llave (SW No. 27).</b></p> <p><b>5. Ejecute la instalación eléctrica según las normas vigentes.</b> <b>¡Atención!</b> Realice los trabajos de mantenimiento con el aparato desconectado. Los trabajos eléctricos sólo deben ser realizados por personal especializado.</p> <p><b>6. En zonas con peligro de heladas monte la calefacción regulada por termostato.</b></p> <p><b>7. El ECO-DRAIN sólo funciona si esta conectado a la corriente eléctrica.</b></p> <p><b>8. No utilice el interruptor de TEST para la purga continua.</b></p> <p><b>9. No utilice el ECO-DRAIN en áreas con peligro de explosiones.</b></p> <p><b>10. Solamente utilice recambios originales.</b> En caso contrario se cancela la garantía.</p>	<p><b>SAFETY RULES</b></p> <p><b>1. Do not exceed max. operating pressure (see type plate)!</b> <b>NOTE:</b> Maintenance work must only be carried out when the device is not under pressure!</p> <p><b>2. Only use pressure-proof installation material!</b> The feed line (½") must be firmly fixed. Discharge line: short pressure hose to pressure-proof pipe. Please ensure that condensate cannot squirt onto persons or objects.</p> <p><b>3. If conical connectors are used on the inlet side, avoid excessive tightening of the connectors.</b></p> <p><b>4. For locking or holding in position during installation, use spanner area at inflow point (spanner size 27)!</b></p> <p><b>5. The electrical installation must be carried out in compliance with the valid regulations!</b> <b>NOTE:</b> Maintenance work is only allowed when the device is in a de-energized condition! Electrical work must always be performed by a qualified electrician.</p> <p><b>6. Do not operate the device when there is a danger of frost.</b></p> <p><b>7. The ECO-DRAIN condensate drain will only function when voltage is being applied to the device.</b></p> <p><b>8. Do not use the test button for continuous draining.</b></p> <p><b>9. Do not use the ECO-DRAIN device in hazardous areas (with potentially explosive atmospheres).</b></p> <p><b>10. Only employ original spare parts, otherwise the guarantee will no longer be valid.</b></p>	<p><b>INSTRUÇÕES DE SEGURANÇA</b></p> <p><b>1. Não exceder a pressão de serviço máxima (ver placa indicadora das características)!</b> <b>ATENÇÃO!</b> Só efectuar trabalhos de manutenção com o aparelho isento de pressão!</p> <p><b>2. Só utilizar material de instalação resistente à pressão!</b> A tubagem de entrada dos condensados (½") tem que estar bem fixa. Um tubo flexível resistente à pressão, unido a um tubo rígido também resistente à pressão. Evite que pessoas ou objectos possam atingidos pela descarga do condensado.</p> <p><b>3. Não utilizar racords cónicos na ligação de entrada.</b></p> <p><b>4. Para mudar ou girar o purgador durante a instalação, utilizar uma chave de caixa (SW27) no ponto de entrada dos condensados.</b></p> <p><b>5. Executar a instalação eléctrica em concordância com todas as normas vigentes (VDE 0100)!</b> <b>ATENÇÃO!</b> Só efectuar trabalhos de manutenção com o aparelho isento de pressão! Todos os trabalhos eléctricos só poderão ser executados por pessoal técnico autorizado.</p> <p><b>6. Em áreas ameaçadas por geada, equipar o aparelho com um aquecimento regulado termostaticamente (acessórios).</b></p> <p><b>7. O ECO-DRAIN só funcionará se estiver ligado á corrente eléctrica.</b></p> <p><b>8. Não utilizar o botão de teste para escoamento permanente!</b></p> <p><b>9. Não utilizar o ECO-DRAIN em áreas potencialmente explosivas.</b></p> <p><b>10. Só utilizar peças sobressalentes originais.</b> Caso contrário, extinguirá a garantia.</p>

**Function • Funcionamiento**  
**Functionnement • Funcionamento**

**english**

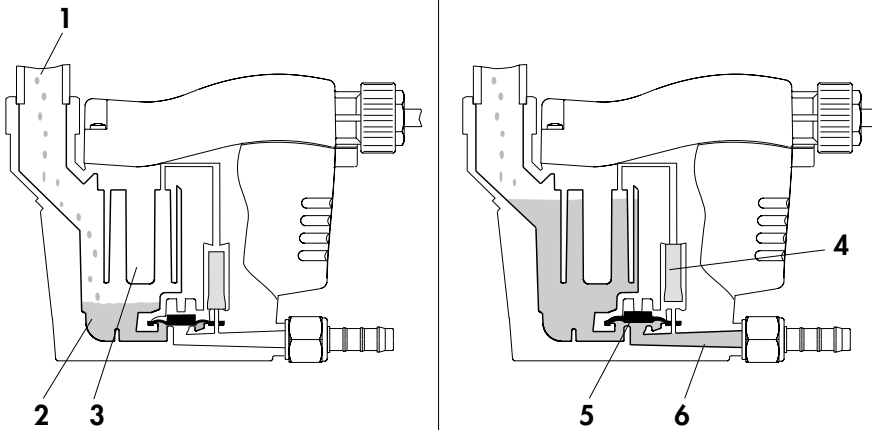

The condensate flows through the feed line (1) into the ECO-DRAIN unit and accumulates in the container (2). A capacitive sensor (3) continuously registers the liquid level and passes a signal to the electronic control as soon as the container is filled. The pilot valve (4) is then activated and the diaphragm (5) opens the outlet line (6) for discharging the condensate. When the ECO-DRAIN unit has been emptied, the outlet line is closed again quickly and tightly without wasting compressed air.

**ECO-DRAIN 21**

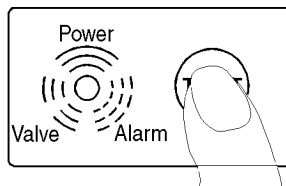
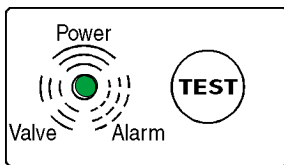

The operating states of the ECO-DRAIN 21 are indicated by one LED with different flashing frequencies.

- 1 Ready for operation  
Power on
- 2 Discharge procedure  
Outlet line open

**ECO-DRAIN 21 PLUS**

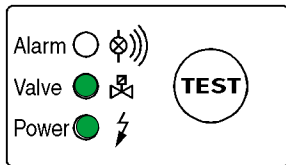
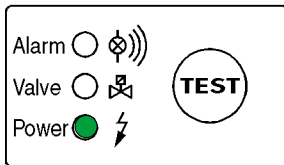

If the condensate discharge is not functioning properly, the valve will keep opening (about every 3 seconds) so as to clear the fault automatically, if possible.

- 3 Malfunction / Alarm
- 4 Test of valve function and manual drainage: briefly press button.

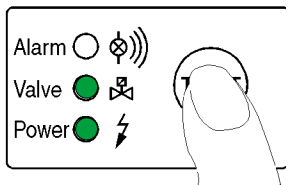
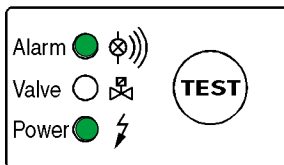

Additional feature of the ECO-DRAIN 21 PLUS: press button for > 1 minute to test the alarm function (s. below).

Switching sequence of valve in alarm mode  
 Secuencia de actuación de la válvula en el modo de alarma  
 Séquence d'activation de la vanne en mode Alarme  
 Sequência de ligação da válvula no modo de alarme

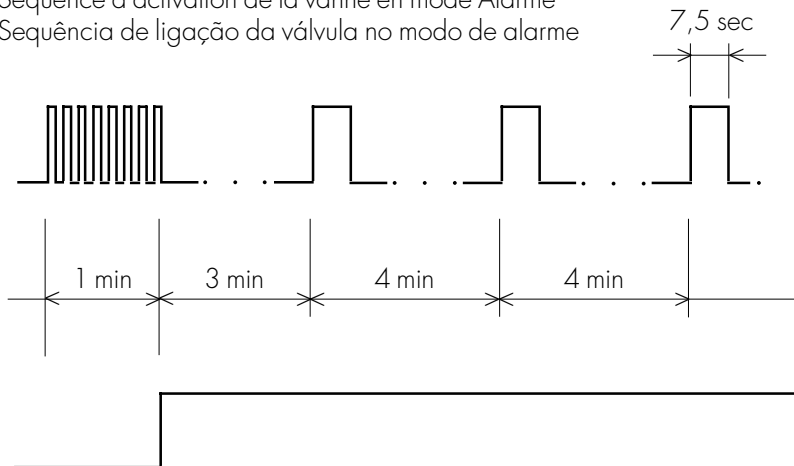

Alarm signal via potential-free contact (only ECO-DRAIN 21 PLUS)  
 Mensaje de alarma a través de contacto sin potencial  
 Signal d'alarme délivré sur le contact sans potentiel (uniqu. ECO-DRAIN 21 PLUS)  
 Sinal de alarme via contacto isento de potência (só ECO-DRAIN 21 PLUS)

**The ECO-DRAIN 21 PLUS also has an alarm-mode function:**

If normal conditions have not been restored after 1 minute, a fault signal will be triggered:

- Alarm LED flashes.
- Alarm signal switches over (can be transmitted via potential-free contact).
- Valve opens every 4 minutes for a period of 7.5 seconds.

Once the fault is cleared, the ECO-DRAIN 21 PLUS will automatically switch back to the normal mode of operation.

**Malfunctioning could be caused by, e.g.:**

- Mistakes during installation
- Dropping below the necessary minimum pressure
- Excessive condensate quantities (overloading)
- Blocked/shut off outlet line
- Extreme amount of dirt particles
- Frozen piping

<b>español</b>	<b>français</b>	<b>português</b>
<p>El condensado fluye a través de la tubería de entrada (1) al ECO-DRAIN y se acumula en el depósito (2). El sensor capacitivo de nivel (3) controla permanentemente el nivel de llenado. Si el depósito está lleno, el sensor emite una señal a la unidad de pilotaje electrónico. Inmediatamente se acciona la válvula de pilotaje (4) y la membrana (5) abre la salida (6) para purgar el condensado. En el momento en el que el ECO-DRAIN esta vacío se cierra la salida herméticamente antes de que se produzca un escape de aire comprimido.</p>	<p>Amené dans le ECO-DRAIN par la conduite d'arrivée (1), le condensat est collecté dans le réservoir (2). Une sonde capacitive (3) surveille en permanence le niveau de remplissage et envoie un signal à la commande électronique dès que le réservoir est rempli. L'électrovanne pilote (4) est activée et la membrane (5) ouvre la conduite d'évacuation (6) pour l'éclusage du condensat. Dès que le ECO-DRAIN est vide, la conduite d'évacuation est à nouveau refermée avec une parfaite étanchéité, avant même que l'air comprimé ne puisse s'échapper.</p>	<p>O condensado flui através do tubo de entrada (1) para o interior do ECO-DRAIN e acumula-se no depósito (2). Um sensor que trabalha capacitivamente (3) vai registando continuamente o nível, transmitindo um sinal á unidade de comando electrónico logo que o depósito estaja cheio de condensado. No momento em que o depósito fica vazio, o orifício de descarga é fechado hermeticamente a fim de se evitar uma perda desnecessária de ar comprimido.</p>
<p>Un diodo indica los estados de funcionamiento del ECO-DRAIN 21 mediante diferentes secuencias de parpadeo.</p> <ol style="list-style-type: none"> <li>1 En funcionamiento. El aparato está bajo tensión</li> <li>2 Proceso de purga. La salida está abierta</li> </ol> <p>Si la salida del condensado está perturbada la válvula se abre en secuencias (aprox. cada 3 segundos), para eliminar la perturbación</p> <ol style="list-style-type: none"> <li>3 Perturbación. El modo de alarma está activado.</li> <li>4 Test. Control funcional de la válvula. Purga manual Active el pulsador durante 2 segundos.</li> </ol> <p>ECO-DRAIN 21 PLUS Adicionalmente posee TEST de la alarma. Active el pulsador durante 1 minuto.</p>	<p>Sur le ECO-DRAIN 21, les états de fonctionnement sont affichés par <b>une</b> LED avec diverses fréq. de clignotement.</p> <ol style="list-style-type: none"> <li>1 Prêt à fonctionner. Tension d'alimentation présente</li> <li>2 Phase de purge. Conduite d'évacuation ouverte</li> </ol> <p>Si l'écoulement du condensat est perturbé, la vanne s'ouvre par intermittences (toutes les 3 s), afin de remédier automatiquement au défaut :</p> <ol style="list-style-type: none"> <li>3 Dysfonctionnement / alarme</li> <li>4 Test du fonctionnement de l'électrovanne et purge manuel le: actionner brièvement la touche.</li> </ol> <p>De plus, sur ECO-DRAIN 21 PLUS: pour tester la fonction alarme (voir ci-dessous) actionner la touche &gt; 1 minute</p>	<p>No ECO-DRAIN 21 há um LED que indica cada um dos estados de funcionamento, através de diferentes sequências de luz intermitente.</p> <ol style="list-style-type: none"> <li>1 Estado pronto a funcionar. Tensão aplicada</li> <li>2 Fase de descarga. Tubo de descarga está aberto</li> </ol> <p>Se o escoamento do condensado estiver obstruído, a válvula abre com sequências de 3 segundos para solucionar automaticamente esta anomalia.</p> <ol style="list-style-type: none"> <li>3 Anomalia/Alarme</li> <li>4 Teste de funcionamento da válvula (drenagem manual): pressionar a tecla durante 2 segundos.</li> </ol> <p>Além disso, no ECO-DRAIN 21 PLUS, para testar a função de alarme (ver em baixo) pressionar a tecla pelo menos 1 minuto.</p>
<p><b>El ECO-DRAIN 21 PLUS tiene adicionalmente una función en modo de alarma:</b> Si después de 1 minuto la perturbación no está eliminada se emite una señal de alarma:</p> <ul style="list-style-type: none"> <li>• El diodo de alarma parpadea</li> <li>• El rele de alarma está activada (la señal esta disponible en el contacto libre de potencial).</li> <li>• La válvula abre cada 4 minutos durante 7,5 segundos.</li> </ul> <p>Quando la perturbación está eliminada el ECO-DRAIN 21 PLUS vuelve automáticamente a su modo normal.</p> <p><b>Posibles causas son p.ej.:</b></p> <ul style="list-style-type: none"> <li>• Fallos en el montaje.</li> <li>• La presión mínima esta por debajo de la indicada.</li> <li>• La cantidad de condensado es demasiado alta.</li> <li>• La tubería de salida está cerrada o taponada.</li> <li>• Cantidad extrema de partículas de suciedad. Tuberia</li> </ul>	<p><b>Le ECO-DRAIN 21 PLUS dispose en plus d'une fonction mode d'alarme :</b> Si un défaut n'est pas résolu au bout d'une minute, un signal de dysfonctionnement est émis:</p> <ul style="list-style-type: none"> <li>• La LED alarme clignote</li> <li>• Le relai d'alarme commute (le signal est délivré sur un contact sans potentiel)</li> <li>• La vanne s'ouvre toutes les 4 minutes, pendant 7,5 secondes</li> </ul> <p>Dès que le défaut est résolu, le ECO-DRAIN 21 PLUS revient automatiquement en mode normal.</p> <p><b>Causes de dysfonctionnement possibles:</b></p> <ul style="list-style-type: none"> <li>• Défaut au niveau de l'installation</li> <li>• Pression minimale non atteinte</li> <li>• Trop de condensat (surcharge)</li> <li>• Ecoulement bouché ou obturé</li> <li>• Importantes quantités d'impuretés</li> <li>• Conduites gelées</li> </ul>	<p><b>O BEKOMAT 21 PRO dispõe adicionalmente de uma função de modo de alarme:</b> Se uma anomalia não se resolver ao fim de 1 minuto, é emitido um sinal de alarme:</p> <ul style="list-style-type: none"> <li>• O LED de alarme começa a piscar</li> <li>• O relé de alarme comuta (o sinal pode ser transmitido via um contacto livre de potência)</li> <li>• A válvula abre durante 7,5 segundos, de 4 em 4 minutos</li> </ul> <p>Quando a anomalia for eliminada, o ECO-DRAIN 21 PLUS retorna automaticamente ao seu funcionamento normal. As possíveis causas de anomalia são, p.ex.:</p> <ul style="list-style-type: none"> <li>• defeitos na instalação</li> <li>• a pressão mínima não foi atingida</li> <li>• quantidades excessivas de condensado (sobrecarga)</li> <li>• tubo de descarga obstruído/bloqueado</li> <li>• grande quantidade de impurezas</li> <li>• tubos congelados</li> </ul>

**Installation • Instalación  
Installation • Instalação**

**english**

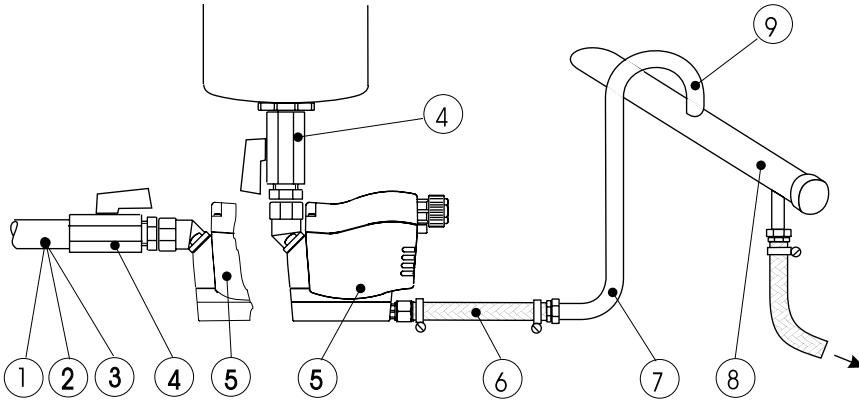

1. Feed pipe at least ½"!
2. No filters in feed line
3. Slope in feed line > 1%!
4. Only use ball valves!
5. Operating pressure: min. 12 psi  
max. 235 psi
6. Short pressure hose!
7. For each metre of rising slope in the outlet line, the required minimum pressure will increase by 0.1 bar. The rise of the outlet line must not exceed 17 feet!
8. Lay collecting line (min. ½" ) with 1% of slope.
9. Lead discharge pipe from the top into collecting line.

**wrong • no correcto  
incorrect • incorrecto**

**correct • correcto  
correct • correcto**

**Note: Pressure differences!**

Each condensate source must be drained separately!

**Note: Venting!**

If the feed line cannot be laid with sufficient slope, it will be necessary to install a venting line!

**Note: Deflector area!**

If drainage is to take place directly from a line, it is advisable to arrange the piping so that the air flow is diverted.

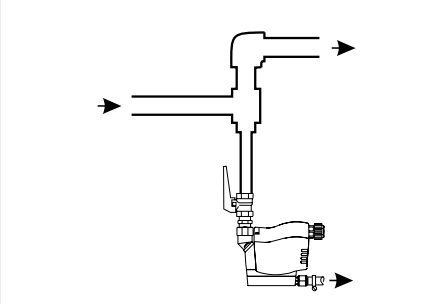
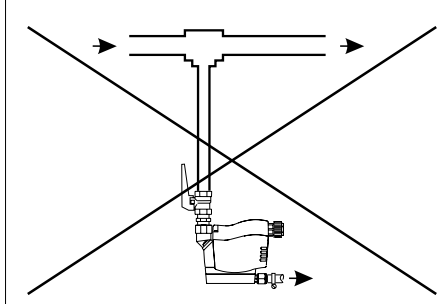
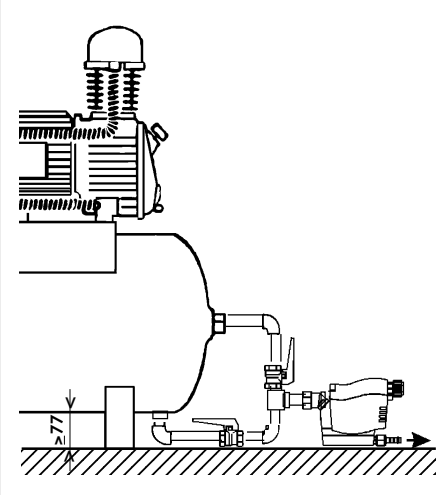
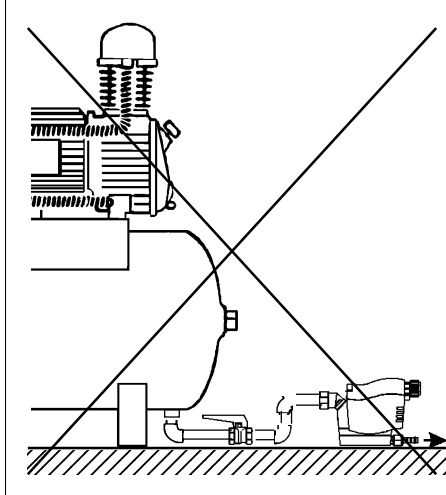
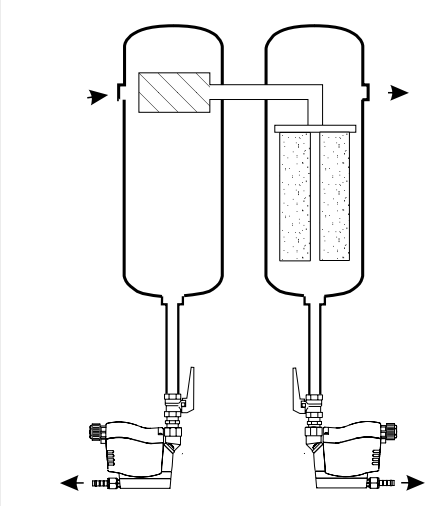
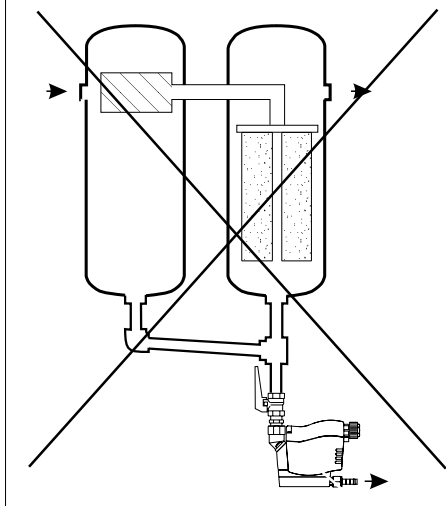

<b>español</b>	<b>français</b>	<b>português</b>
<ol style="list-style-type: none"> <li>1. Tubería de entrada mínimo G<math>\frac{1}{2}</math></li> <li>2. No ponga ningún filtro en la tubería de entrada</li> <li>3. La tubería de entrada tiene que tener una pendiente descendente constante &gt;1%</li> <li>4. Utilice solamente llaves de paso esféricas.</li> <li>5. Presión de trabajo: mínimo 0,8 bar máximo 16 bar</li> <li>6. Tubo a presión corto.</li> <li>7. Por cada metro que asciende la tubería de salida, se incrementa la presión mínima de funcionamiento en 0,1 bar. Subida máxima de la tubería de salida: 5 m</li> <li>8. Tubería colectora de los condensados: mínimo <math>\frac{1}{2}</math>" con pendiente descendente constante de 1%.</li> <li>9. La salida de los condensados entra por arriba con un cuello de cisne en la tubería colectora.</li> </ol>	<ol style="list-style-type: none"> <li>1. Tube d'amenée, au moins G<math>\frac{1}{2}</math> !</li> <li>2. Pas de filtre sur l'amenée !</li> <li>3. Pente de l'amenée &gt;1% !</li> <li>4. Utiliser uniquement des vannes à boisseau sphérique !</li> <li>5. Pression de service: min. 0,8 bar max. 16 bar (relever la pression sur la plaque)</li> <li>6. Flexible pression de faible longueur!</li> <li>7. Evacuation : longueur max. de la partie montante : 5 m !</li> <li>8. Conduite collectrice : au minimum <math>\frac{1}{2}</math>" avec 1% de pente!</li> <li>9. La conduite d'écoulement doit être raccordée par un col de cygne sur la conduite collectrice</li> </ol>	<ol style="list-style-type: none"> <li>1. Diâmetro mínimo do tubo adutor G<math>\frac{1}{2}</math>!</li> <li>2. Não montar filtros no tubo adutor!</li> <li>3. Declive de afluência &gt;1%!</li> <li>4. Só utilizar válvulas esféricas!</li> <li>5. Pressão de trabalho: mín. 0,8 bar max. 16 bar</li> <li>6. Tubo flexível curto!</li> <li>7. Por cada metro de subida no tubo de descarga, a pressão mínima necessária vai aumentando em 0,1 bar! O tubo de descarga não deve exceder 5 m de subida!</li> <li>8. Instalar tubagem colectora com diâmetro mínimo de 5 m e 1% de pente!</li> <li>9. A tubagem de saída dos condensados liga, por cima, á tubagem colectora fazendo o chamado "pescoco de cavalo".</li> </ol>
<p><b>Observe: diferencial de presión</b></p> <p>Se tiene que purgar por separado cada punto de purga.</p>	<p><b>Important: différences de pression !</b></p> <p>Chaque point de soutirage de condensat doit être purgé individuellement !</p>	<p><b>Importante: diferenças de pressão.</b></p> <p>Cada fonte de condensado terá que ser drenada separadamente.</p>
<p><b>Observe: compensación</b></p> <p>Si no hay suficiente pendiente descendente constante en la tubería de la entrada se tiene que montar una tubería de compensación.</p>	<p><b>Important : équilibrage d'air !</b></p> <p>Si la pente de l'amenée n'est pas suffisante, il faut poser une conduite d'équilibrage d'air !</p>	<p><b>Importante: tubo de equilíbrio.</b></p> <p>Se o declive da afluência não for suficiente, deve montar-se um tubo de equilíbrio.</p>
<p><b>Observe: separación de los condensados</b></p> <p>Si se quiere purgar una tubería, es mejor, si se realiza una desviación de la corriente de aire comprimido.</p>	<p><b>Important : chicane !</b></p> <p>Si la purge doit s'effectuer directement sur la tuyauterie, il faut prévoir une chicane pour que le condensat ne soit pas entraîné par le débit d'air comprimé !</p>	<p><b>Importante: desvio instalação na tubagem.</b></p> <p>Quando se pretende purgar uma tubagem, é preferível instalar o purgador conforme desenho.</p>

**Installation • Instalación  
Installation • Instalação**

**english**

**wrong • no correcto  
incorrect • incorrecto**

**correct • correcto  
correct • correcto**

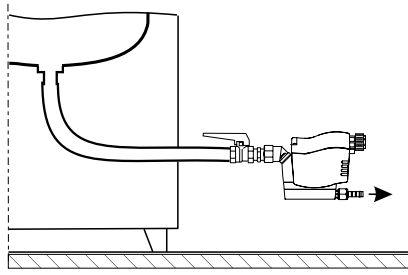
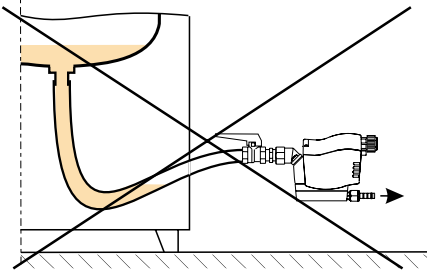

**Note: Continuous slope**

It is important to avoid water pockets when using a pressure hose as a feed line!

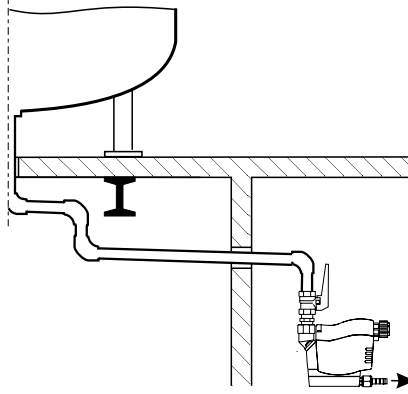
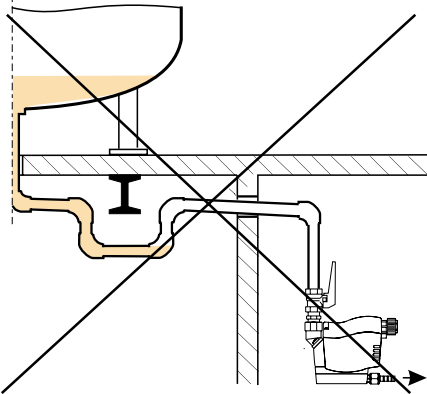

**Note: Continuous slope!**

Water pockets must also be avoided when laying a feed pipe.

**Electrical installation • Instalación eléctrica  
Installation électrique • Instalação elétrica**

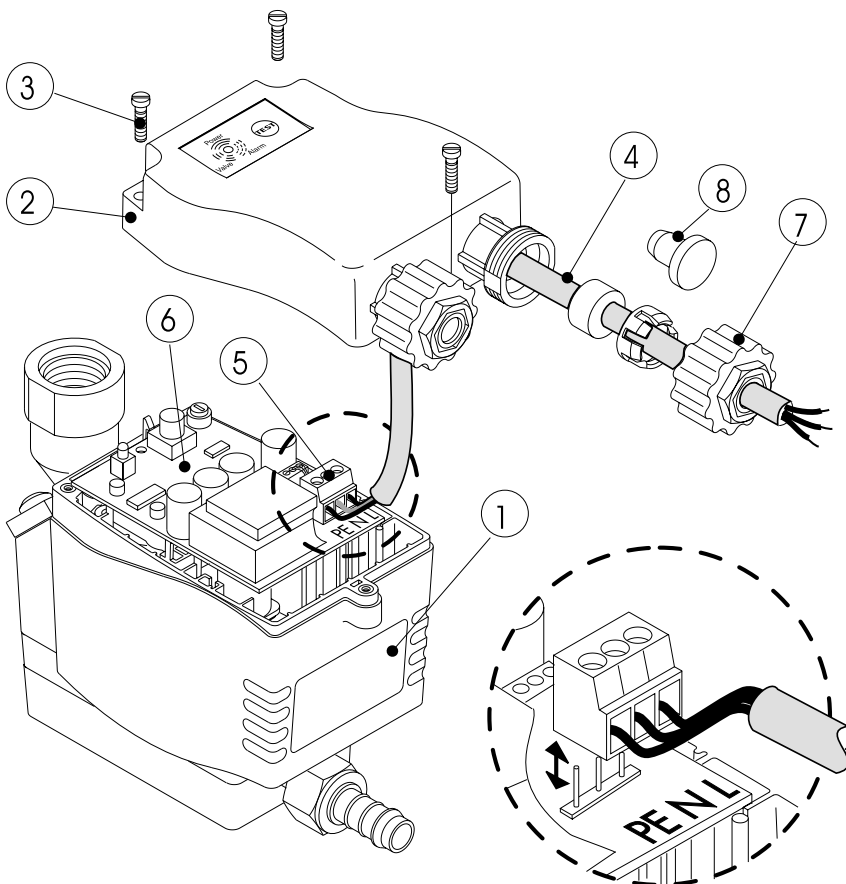

**ECO-DRAIN 21**

**Note before wiring:**

- Check type plate (1) for permissible mains voltage and ensure conformity!
- Please ensure that the installation is carried out according to the valid regulations.
- Please assign terminals as indicated!

- Remove screws (3) and lift off housing top (2)
- Unscrew cable fitting (7), remove blanking disk (8) and guide 3-core cable for power supply (4) through cable fitting.
- Join cable to terminal connector (5) (The terminal connector can be pulled off.)

**Terminal assignment**

L = phase conductor (black)  
N = neutral conductor (white)  
PE = ground (green)

- Plug terminal connector (5) to control PCB (6)
- Pull cable (4) tight and screw down cable fitting (7)
- Put back housing top and tighten screws (3)

<b>español</b>	<b>français</b>	<b>português</b>
<p><b>Observe: pendiente descendente constante</b></p> <p>Si se emplea como entrada un tubo flexible, se tiene que evitar que se forme un sifón.</p>	<p><b>Important: pente continue !</b></p> <p>Si l'amenée est réalisée au moyen d'un flexible, il faut éviter toute "retenue d'eau" !</p>	<p><b>Importante: declive contínuo.</b></p> <p>Quando se utiliza um tubo flexível para a entrada do condensado, tem que se evitar a formação de um sifão.</p>
<p><b>Observe: pendiente descendente constante</b></p> <p>Si se emplea como entrada un tubo rígido, se tiene que evitar que se forme un sifón.</p>	<p><b>Important: pente continue !</b></p> <p>Si l'amenée est réalisée au moyen d'une tuyauterie rigide, il faut aussi éviter toute "retenue d'eau" !</p>	<p><b>Importante: declive contínuo.</b></p> <p>Quando se utiliza um tubo rígido para a entrada do condensado, tem que se evitar a formação de um sifão.</p>
<p><b>ECO-DRAIN 21</b></p> <p><b>Antes de la instalación eléctrica:</b></p> <ul style="list-style-type: none"> <li>• Verifique y respete imperativamente la tensión admisible en la placa (1).</li> <li>• Ejecute los trabajos de instalación según las normas UNE vigentes.</li> <li>• Observe la asignación de los bornes.</li> </ul> <ul style="list-style-type: none"> <li>• Afloje los tornillos (3) y desmonte la tapa superior (2)</li> <li>• Suelte la rosca para cables (7), quite el tapón (8) y guíe un cable de alimentación (5) de tres conductores a través de la tuercas</li> <li>• Conecte el cable en el conector extraíble (5).</li> </ul> <p><b>Asignación de los bornes</b></p> <p>L = fase (negro) N = neutro (azul) PE = tierra (verde/amarillo)</p> <ul style="list-style-type: none"> <li>• Conecte el conector (5) con la platina (6)</li> <li>• Ajuste el cable (4) y monte la rosca para cables (7)</li> <li>• Fije la tapa superior con los tornillos (3)</li> </ul>	<p><b>ECO-DRAIN 21</b></p> <p><b>A noter avant l'installation électrique:</b></p> <ul style="list-style-type: none"> <li>• Respecter impérativement la tension secteur admissible mentionnée sur la plaque signalétique (1) !</li> <li>• Réaliser les travaux d'installation conformément à VDE 0100.</li> <li>• Respecter l'affectation des bornes !</li> </ul> <ul style="list-style-type: none"> <li>• Desserrer les vis (3) et retirer le capot du boîtier (2)</li> <li>• Desserrer le presse-étoupe (7), retirer l'obturateur (8) et enfiler le câble à 3 conducteurs (4) assurant l'alimentation électrique</li> <li>• Raccorder le câble au bornier enfichable (5)</li> </ul> <p><b>Affectation des bornes</b></p> <p>L = phase (noir) N = neutre (bleu) PE = terre (vert/jaune)</p> <ul style="list-style-type: none"> <li>• Tendre le câble (4) et serrer le presse-étoupe (7)</li> <li>• Enficher le bornier (5) sur la carte électronique (6).</li> <li>• Fixer le capot du boîtier à l'aide des vis (3)</li> </ul>	<p><b>ECO-DRAIN 21</b></p> <p><b>Antes de proceder à instalação eléctrica, observar o seguinte:</b></p> <ul style="list-style-type: none"> <li>• Consultar na placa indicadora das características (1) a tensão de rede admissível e respeitá-la rigorosamente.</li> <li>• Realizar os trabalhos de instalação seguindo a norma VDE 0100.</li> <li>• Respeitar a ocupação dos bornes.</li> </ul> <ul style="list-style-type: none"> <li>• Desapertar os parafusos (3) e retirar a tampa da caixa (2)</li> <li>• Desapertar a união roscada do cabo (7), retirar o bujão de vedação (8) e enfiar o cabo de 3 condutores (4) para o abastecimento de energia</li> <li>• Ligar o cabo à caixa de bornes (5) (o conector dos bornes é removível)</li> </ul> <p><b>Ocupação dos bornes</b></p> <p>L = condutor externo (preto) N = condutor neutro (azul) PE = condutor protector (verde/amarelo)</p> <ul style="list-style-type: none"> <li>• Encaixar o conector dos bornes (5) na placa (6).</li> <li>• Esticar o cabo (4) e apertar bem a união roscada do cabo (7)</li> <li>• Fixar a tampa da caixa com os parafusos (3)</li> </ul>

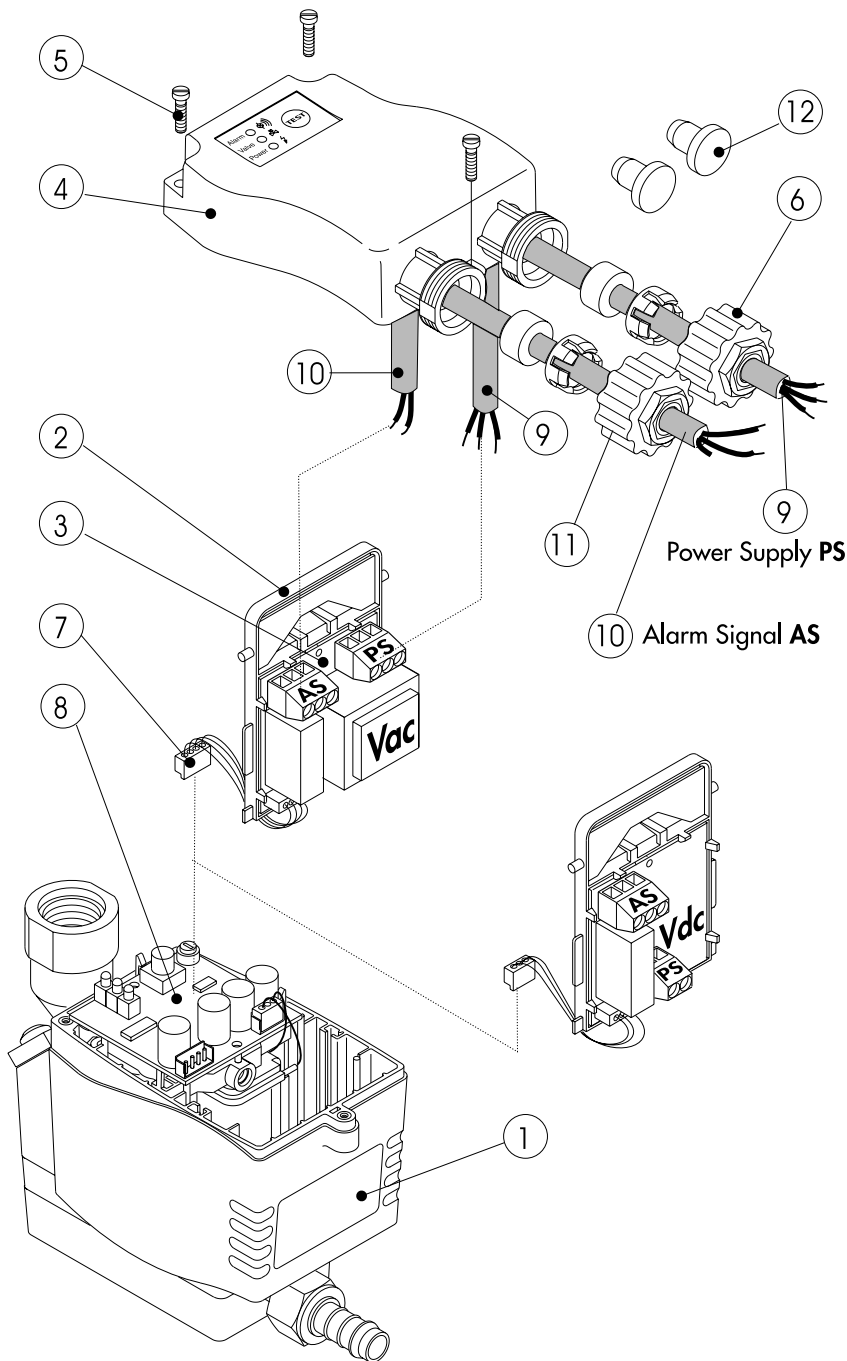

**Vac - voltages**

phase	neutral	earth/ground	normally closed	common	normally open
L	N	PE			

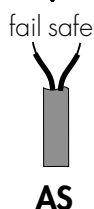
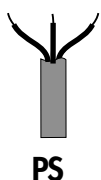

**Vdc - voltage**

			+24 Vdc (OV)	OV (+24 Vdc)	normally closed	common	normally open
			±24V	±24V			

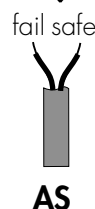
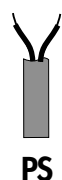

**ECO-DRAIN 21 PLUS**

**Note before wiring:**

- The mains voltage must correspond to the permissible voltage on the type plate (1)!
- Please ensure that the installation is carried out according to the valid regulations.
- Please assign terminals as indicated!

- Remove screws (5) and lift off housing top (4) paying attention to the cable.
- Unplug connector (7) from terminal on control PCB (8).
- Fit board holder (2) with power supply board into the housing top (4).

**Connect power supply**

- Unscrew union nut (6) and remove blanking disk (12)
- Guide a 3-core cable (9) for power supply through screwed cable fitting and connect to board terminal PS.

**Terminal assignment in the case of Vac devices:**

- L = phase conductor (black)
- N = neutral conductor (white)
- PE = ground (green)

**In the case of Vdc devices (direct current) the poling can be chosen as desired: ± 24 Vdc**

**Potential-free alarm contact**

- Guide 3-core cable (10) through cable fitting (11) and connect to board terminal AS (changeover contact).

**N.C.-COM:**

Contact closed during malfunction or power failure (fail-safe principle).

**N.O.-COM:**

Contact closed during normal operation.

**External test button (optional)**

Use separate connecting lead!

**Assembly**

- Pull cables (9+10) tight and screw down cable fittings (6+11)
- Move board holder (2) with power supply board upwards (must click into place).
- Plug connector (7) to terminal on control PCB (8).
- Slide housing top (4) with board holder (2) into the guiding grooves.
- Tighten the screws (5).



español	français	português
<p><b>ECO-DRAIN 21 PLUS</b></p> <p><b>Antes de la instalación eléctrica:</b></p> <ul style="list-style-type: none"> <li>• Verifique y respete imperativamente la tensión admisible en la placa (1).</li> <li>• Ejecute los trabajos de instalación según las normas UNE vigentes.</li> <li>• Observe la asignación de los bornes.</li> </ul> <ul style="list-style-type: none"> <li>• Afloje los tornillos (5) y desmonte la tapa superior (4) (Atención al cable)</li> <li>• Quite el conector de alimentación (7) de la platina de alimentación (8)</li> <li>• Monte el soporte (2) de la platina de alimentación en la tapa superior (4)</li> </ul> <p><b>Conecte la tensión eléctrica.</b></p> <ul style="list-style-type: none"> <li>• Suelte la rosca para cables (6), quite el tapón (12)</li> <li>• Guíe un cable de alimentación (9) de tres conductores a través de las tuercas y conéctelo en el borne con la denominación <b>PS</b>.</li> </ul> <p><b>Asignación de los bornes en aparatos de corriente alterna.</b> L = fase (negro) N = neutro (azul) PE = tierra (verde/amarillo)</p> <p><b>En aparatos de 24 Vcc (corriente continua) la polarización no tiene importancia: ± 24Vdc</b></p> <p><b>Contacto sin potencial para la transmisión de la señal de alarma.</b></p> <ul style="list-style-type: none"> <li>• Guíe un cable (10) de tres conductores a través de las tuercas (11) y conéctelo en el borne con la denominación <b>AS</b> (contacto abierto/cerrado).</li> </ul> <p><b>N.C.-COM:</b> El contacto está cerrado si ocurre una perturbación o una caída de tensión (seguridad positiva)</p> <p><b>N.O.-COM:</b> El contacto está cerrado con funcionamiento normal</p> <p><b>Pulsador adicional de test</b> (opcional) Observe el manual de instalación adicional.</p> <p><b>Montaje</b></p> <ul style="list-style-type: none"> <li>• Ajuste los cables (9+10) y monte la rosca para cables (6+11)</li> <li>• Doble el soporte de la platina de alimentación (2) hacia arriba (debe escucharse un "click")</li> <li>• Conecte el conector de alimentación (7) con la platina de alimentación (8).</li> <li>• Coloque la tapa superior (4) en las ranuras de guía.</li> <li>• Fije la tapa superior con los tornillos (5)</li> </ul>	<p><b>ECO-DRAIN 21 PLUS</b></p> <p><b>A noter avant l'installation électrique:</b></p> <ul style="list-style-type: none"> <li>• Seule la tension secteur mentionnée sur la plaque signalétique (1) est admissible!</li> <li>• Réaliser les travaux d'installation conformément à VDE 0100.</li> <li>• Respecter l'affectation des bornes ! • Desserrer les vis (5) et retirer le capot du boîtier (4) (attention au câble)</li> <li>• Débrancher le connecteur d'alimentation (7) sur la carte de commande (8).</li> <li>• Pour accéder aux borniers, faire pivoter sur le capot (4) la carte d'alimentation secteur (2).</li> </ul> <p><b>Brancher l'alimentation secteur</b></p> <ul style="list-style-type: none"> <li>• Desserrer l'écrou (6) du presse-étoupe et retirer l'obturateur (12)</li> <li>• Enfiler le câble à 3 conducteurs (9) assurant l'alimentation électrique, à travers le presse-étoupe, et le raccorder au bornier <b>PS</b> de la carte.</li> </ul> <p><b>Affectation des bornes sur les appareils Vac (alimentés en alternatif)</b> L = phase (noir) N = neutre (bleu) PE = terre (vert/jaune)</p> <p><b>Sur les appareils 24 Vdc (alimentés en continu) la polarité n'a pas d'importance: ± 24Vdc</b></p> <p><b>Contact d'alarme, sans potentiel</b></p> <ul style="list-style-type: none"> <li>• Enfiler un câble à 3 fils (10), (à 5 fils en cas d'utilisation d'un „bouton TEST externe“), à travers le presse-étoupe (11) et le raccorder au bornier <b>AS</b> de la carte (<b>inverseur</b>)</li> </ul> <p><b>N.C.-COMMON:</b> Contact fermé en cas de dysfonctionnement ou de coupure de courant (sécurité positive)</p> <p><b>N.O.-COMMON:</b> Contact fermé en fonctionnement normal</p> <p><b>Bouton Test externe</b> (en option) Suivre les instructions de branchement séparées !</p> <p><b>Montage</b></p> <ul style="list-style-type: none"> <li>• Tendre les câbles (9+10) et serrer les presse-étoupes (6+11)</li> <li>• Pivoter la carte d'alimentation (2) (jusqu'à l'encliquetage)</li> <li>• Enfiler le connecteur d'alimentation (7) sur la carte de commande (8).</li> <li>• Monter le capot du boîtier (4) en engageant la carte (2) dans les rails de guidage.</li> <li>• Serrer les vis (5)</li> </ul>	<p><b>ECO-DRAIN 21 PLUS</b></p> <p><b>Antes de proceder à instalação eléctrica, observar o seguinte:</b></p> <ul style="list-style-type: none"> <li>• Consultar na placa indicadora das características (1) a tensão de rede admissível e respeitá-la rigorosamente.</li> <li>• Realizar os trabalhos de instalação seguindo a norma VDE 0100.</li> <li>• Respeitar a ocupação dos bornes.</li> <li>• Desapertar os parafusos e retirar a tampa da caixa (4) (ter atenção ao cabo)</li> <li>• Retirar da placa de comando (8) o conector de alimentação (7).</li> <li>• Montar o suporte (2) com a placa de alimentação na tampa superior.</li> </ul> <p><b>Ligação da tensão eléctrica</b></p> <ul style="list-style-type: none"> <li>• Desapertar a porca de capa (6) e retirar o bujão de vedação (12)</li> <li>• Passar o cabo de 3 condutores (9) destinado à alimentação eléctrica através da união roscada do cabo e conectá-lo ao borne da placa <b>PS</b></li> </ul> <p><b>Ocupação dos bornes com aparelhos de corrente alterna:</b> L = condutor externo (preto) N = condutor neutro (azul) PE = condutor protector (verde/amarelo)</p> <p><b>Com aparelhos 24 Vdc (tensão de corrente contínua) a polaridade é variável: ± 24Vdc</b></p> <p><b>Contacto de alarme livre de tensão</b></p> <ul style="list-style-type: none"> <li>• Enfiar um cabo de 3 condutores (10) através da união roscada do cabo (11) e ligá-lo ao borne da placa <b>AS</b> (<b>contacto aberto/fechado</b>)</li> </ul> <p><b>N.C.-COM:</b> Contacto fechado no caso de anomalia ou falha de tensão (princípio de segurança positiva)</p> <p><b>N.O.-COM:</b> contacto fechado com funcionamento normal</p> <p><b>Tecla de teste externo</b> (opcional) Seguir as instruções de ligação fornecidas em separado!</p> <p><b>Montagem</b></p> <ul style="list-style-type: none"> <li>• Esticar os cabos (9+10) e apertar bem as uniões roscadas dos cabos (6+11)</li> <li>• Virar para cima o receptáculo da placa (2) com a placa de alimentação (tem de engatar)</li> <li>• Encaixar o conector de alimentação (7) na placa de comando (8).</li> <li>• Empurrar a tampa da caixa (4) com o receptáculo da placa (2) para dentro das ranhuras de guia.</li> <li>• Apertar os parafusos (5).</li> </ul>

<b>Electrical data • Características eléctricas</b> <b>Caractéristiques électrique • Características eléctricas</b>			<b>english</b>
	<b>230/110/24/... Vac</b>	<b>24 Vdc</b>	<p><b>ECO-DRAIN 21 PLUS</b> <b>POTENTIAL-FREE CONTACT</b> The alarm signal can be relayed via a potential-free contact. The changeover contact can be operated, e.g., in the fail-safe mode.</p> <p>When operating voltage is being applied and the ECO-DRAIN device is functioning correctly, the alarm relay is energized. The contact element (N.O.-COM).</p> <p>When there is no operating voltage or in the case of a fault signal, the alarm relay drops out. The contact element is open (alarm).</p> <p><b>EXTERNAL TEST BUTTON (optional)</b> Here, the normal test button function has been extended for additional use outside the ECO-DRAIN unit. This makes it possible to discharge any condensate in the unit by remote control, if required. When the external contact closes, the valve will open.</p>
Max. power input and fuse protection Potencia máx. absorbida y fusible recomendado Consommation maximale et fusibles Potência máx. absorvida e fusível recomendado	$P < 2,0 \text{ VA}$ $0,5 \text{ A}^*)$	$P < 2,0 \text{ W}$ $100 \text{ mA}^*)$	
Supply voltage (see type plate) Tensión de entrada (ver etiqueta identificativa) Alimentation électrique (voir plaque sign.) Tensão de rede (ver placa indicadora)	$U_{ac} = \dots \pm 10\%$ $50 - 60 \text{ Hz}$	$U_0 = 24 \text{ Vdc}$ $-10/+25\%$	
Cable cross-section and fuse protection Sección de cable y fusible Section des fils et fusibles Secção do cabo e fusível recomendado	max. diameter 3/8" 2 amp fuse		
Contact loading relay or OUT1 Carga del contacto relé o salida 1 (OUT1) Pouvoir de coupure Relais ou OUT1 Carga de contato Relé ou OUT1	$< 250 \text{ Vac} / < 1,0 \text{ A}$ $> 5 \text{ Vdc} / > 10 \text{ mA}$		
*) mittelträge/...../...../de ação média lenta			
<b>Maintenance • Mantenimiento • Entretien • Manutenção</b>			
			<p><b>Before maintenance work always ensure that the device is:</b></p> <ul style="list-style-type: none"> <li>• pressureless and</li> <li>• de-energized.</li> </ul> <p><b>Maintenance recommendation:</b></p> <ul style="list-style-type: none"> <li>• Remove 2 pan head screws (1) and lift off ECO-DRAIN. The elbow adaptor stays in place.</li> <li>• Disconnect discharge hose (2).</li> <li>• Turn the 6 pan head screws (3) until heads are level with the outer edge and take off diaphragm seat (4).</li> <li>• Replace wearing parts (x)</li> <li>• Reassemble ECO-DRAIN unit in reverse order.</li> </ul> <p>Set of wearing parts (x) Order reference AN825200</p>
<b>ECO-DRAIN 21</b>		<b>ECO-DRAIN 21 PLUS</b>	
<p><b>Functional test of ECO-DRAIN device:</b></p> <ul style="list-style-type: none"> <li>• Briefly press test button. → Valve opens for condensate discharge.</li> </ul> <p><b>ECO-DRAIN 21 PLUS:</b> <b>Checking of alarm signal:</b></p> <ul style="list-style-type: none"> <li>• Shut off condensate inflow.</li> <li>• Press test button for at least 1 minute. → Red LED flashes → Alarm signal is being relayed</li> </ul>			

<b>español</b>	<b>français</b>	<b>português</b>
<p><b>ECO-DRAIN 21 PLUS</b></p> <p><b>CONTACTO LIBRE DE POTENCIAL</b> A través del contacto libre de potencial se puede transmitir la señal de alarma (por ejemplo a una sala de control). El contacto puede trabajar p.ej. en el modo "fail-safe":</p> <p>Bajo tensión eléctrica el ECO-DRAIN trabaja sin perturbación, el relé de alarma está cerrado. El contacto de trabajo (N.O.-COM) está cerrado.</p> <p>Desconectando la tensión eléctrica o produciéndose la señal de alarma, el relé se abre. El contacto de trabajo está abierto (alarma).</p> <p><b>Pulsador de "TEST" externo (opcional).</b> Posibilidad de purgar condensado por control remoto. Hay contactos de la función de "TEST". La purga es realizada cuando se cierra el contacto externo.</p>	<p><b>ECO-DRAIN 21 PLUS</b></p> <p><b>CONTACT SANS POTENTIEL</b> Un contact sans potentiel permet le report de l'alarme. Le contact inverseur peut être exploité par exemple en mode fail-safe :</p> <p>Si la tension de service est présente et si le ECO-DRAIN fonctionne normalement, le relais d'alarme est excité. Le contact de travail (N.O.-COM) est fermé.</p> <p>Si la tension d'alimentation n'est pas présente ou si un signal d'alarme est émis, le relais d'alarme est désexcité. Le contact de travail est ouvert (Alarme).</p> <p><b>BOUTON TEST EXTERNE (en option)</b> Celui-ci permet d'effectuer une commande à distance de la purge. La fonction normale de la touche Test est ainsi reportée sur un contact externe. Lorsque ce contact est fermé, la vanne s'ouvre.</p>	<p><b>ECO-DRAIN 21 PLUS</b></p> <p><b>CONTActo livre de tensão</b> O sinal de alarme pode ser transmitido através de um conctato livre de tensão (p. ex. para uma estação de monitorização). O contacto de comutação pode ser operado, p. ex., no <b>modo à prova de fail-safe:</b> Quando há tensão de serviço e quando ECO-DRAIN trabalha sem perturbações, o relé de alarme está fechado. O contacto de trabalho (N.O.-COM) está fechado. Quando não há tensão de serviço ou quando o aparelho dá sinal de falha, o relé de alarme é desoperado. O contacto de trabalho está aberto (alarme)</p> <p><b>TECLA DE TESTE EXTERNO (opção)</b> Esta tecla permite efectuar um comando à distância da purga. A função normal da tecla de teste foi ampliada para uso adicional fora do ECO-DRAIN. Quando o contato externo é fechado, a válvula abre-se.</p>
<p><b>Antes de cada trabajo de mantenimiento:</b></p> <ul style="list-style-type: none"> <li>• Despresurice el ECO-DRAIN</li> <li>• Desconecte la corriente eléctrica</li> </ul> <p><b>Recomendaciones para el mantenimiento:</b></p> <ul style="list-style-type: none"> <li>• Desenroscar los 2 tornillos cilíndricos (1) y quitar el ECO-DRAIN. El adaptador queda montado.</li> <li>• Desmontar el tubo flexible (2) de la salida.</li> <li>• Desenroscar los 6 tornillos cilíndricos (3), quitar el asiento de la membrana</li> <li>• Cambiar las piezas de desgaste (x)</li> <li>• Montar el ECO-DRAIN correctamente.</li> </ul> <p>Juego de piezas de desgaste: (x) Referencia AN825200</p>	<p><b>Avant chaque entretien:</b></p> <ul style="list-style-type: none"> <li>• Dépressuriser le ECO-DRAIN !</li> <li>• Débrancher l'alimentation électrique du ECO-DRAIN !</li> </ul> <p><b>Recommandations pour l'entretien :</b></p> <ul style="list-style-type: none"> <li>• Desserrer les 2 vis à tête cylindrique (1) et retirer le ECO-DRAIN; l'adaptateur orientable reste sur la tuyauterie.</li> <li>• Retirer le flexible d'écoulement (2)</li> <li>• Desserrer les 6 vis à tête cylindrique (3) (jusqu'à ce que la tête affleure l'arête extérieure) et retirer le siège de la membrane (4)</li> <li>• Remplacer les pièces d'usure (x)</li> <li>• Remonter correctement le ECO-DRAIN</li> </ul> <p><b>Kit de pièces d'usure correspondant: (x)</b> N°de commande AN825200</p>	<p><b>Antes de cada intervenção de manutenção</b></p> <ul style="list-style-type: none"> <li>• Depressurizar o ECO-DRAIN</li> <li>• Desligar o ECO-DRAIN da corrente eléctrica!</li> </ul> <p><b>Recomendações para a manutenção:</b></p> <ul style="list-style-type: none"> <li>• Desapertar os 2 parafusos de cabeça cilíndrica (1) e retirar o ECO-DRAIN; O adaptador orientável fica no sistema</li> <li>• Retirar o tubo de descarga (2)</li> <li>• Desapertar os 6 parafusos de cabeça cilíndrica (3) (até a cabeça ficar nivelada para com o bordo exterior), retirar o assento do diafragma</li> <li>• Substituir as peças de desgaste (x)</li> <li>• Montar o ECO-DRAIN seguindo as instruções</li> </ul> <p>Kit de peças de desgaste: (x) N.ºde encomenda AN825200</p>
<p><b>Control del funcionamiento ECO-DRAIN:</b></p> <ul style="list-style-type: none"> <li>• Accione el pulsador "TEST" durante 2 segundos. → è la válvula abre para la evacuación del condensado.</li> </ul> <p><b>ECO-DRAIN 21 PLUS:</b></p> <p><b>Control del funcionamiento de la alarma:</b></p> <ul style="list-style-type: none"> <li>• Cierre la entrada de los condensados</li> <li>• Accione el pulsador "TEST" durante mínimo 1 minuto → è El diodo rojo está iluminado → è La señal de alarma se está transmitiendo</li> </ul>	<p><b>Test de fonctionnement du ECO-DRAIN:</b></p> <ul style="list-style-type: none"> <li>• Presser la touche Test pendant 2 s → la soupape s'ouvre pour la purge</li> </ul> <p><b>ECO-DRAIN 21 PLUS:</b></p> <p><b>Vérification du signal d'alarme :</b></p> <ul style="list-style-type: none"> <li>• Obturer l'arrivée de condensat</li> <li>• Presser la touche Test pendant 1 minute au moins → la LED rouge clignote → le signal d'alarme est activé</li> </ul>	<p><b>Testar o funcionamento do BEKOMAT:</b></p> <ul style="list-style-type: none"> <li>• Pressionar a tecla de teste por durante 2 segundos → A válvula abre-se para escoamento do condensado.</li> </ul> <p><b>Controlar o sinal de alarme:</b></p> <ul style="list-style-type: none"> <li>• Bloquear a entrada de condensado</li> <li>• Pressionar a tecla de teste pelo menos 1 minuto → O LED vermelho pisca → O sinal de alarme é activado</li> </ul>

**Trouble shooting • Busqueda de fallos  
Recherche de panne • Localização de avarias**

**english**

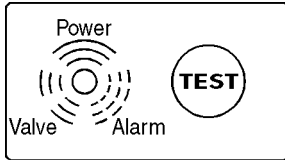

**No LED lighting up  
ningún LED está iluminado  
Aucune LED n'est allumée**

**Possible causes:**

- Power supply faulty
- Power supply board defective
- Control PCB defective

- Check voltage on type plate.
- Check wiring (external and internal)
- Check plug connections
- Check printed circuit boards for possible damage

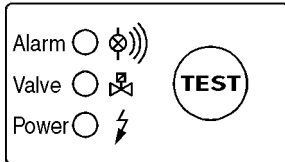

**Todos os LEDs apagados**

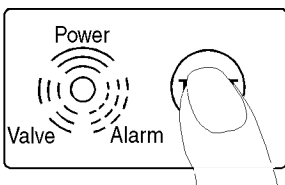

**Pressing of test button, but no condensate discharge  
El interruptor de „TEST“ está pulsado, pero el condensado no se evacua**

**Possible causes:**

- Feed and/or outlet line shut off or blocked
- Worn parts (seals, valve core, diaphragm)
- Control PCB defective
- Solenoid valve defective
- Dropping below necessary minimum pressure

- Check feed line and outlet line
- Replace worn parts
- Check if valve opens audibly (press test button several times)
- Check printed circuit boards for possible damage
- Check operating pressure; where necessary, install pressure or vacuum drains.

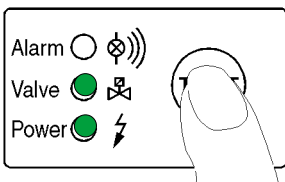

**La touche Test est actionnée, mais sans purge du condensat**

**Botão de teste premido, mas não há descarga de condensado**

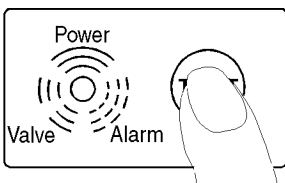

**Condensate discharge only when test button is being pressed**

**Evacuación del condensado sólo si está pulsado el interruptor de „TEST“**

**Possible causes:**

- Feed line with insufficient slope; cross-section too small.
- Excessive condensate quantities
- Sensor tube extremely dirty

- Lay feed line with adequate slope
- Install venting line
- Clean sensor tube

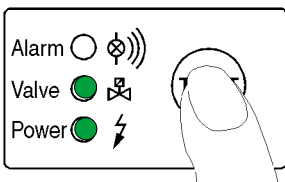

**Purge du condensat uniquement si la touche Test est actionnée**

**Descarga de condensado sólo con o botón de teste premido**

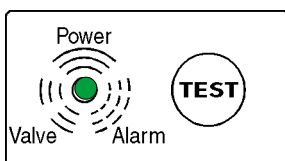

**Device keeps blowing off air**

**El aparato está abierto constantemente**

**Possible causes:**

- Control air line blocked
- Worn parts (seals, valve core, diaphragm)

- Clean entire valve unit
- Replace worn parts
- Clean sensor tube

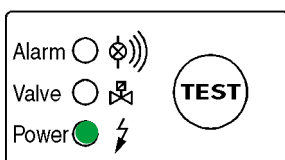

**L'appareil refoule de l'air en permanence**

**O purgador perde ar continuamente**

<b>español</b>	<b>français</b>	<b>português</b>
<p><b>Posibles causas:</b></p> <ul style="list-style-type: none"> <li>tensión de la entrada no correcta</li> <li>fuelle de alimentación defectuosa</li> <li>circuito de pilotaje defectuoso</li> </ul> <p>→ Verifique la tensión de la etiqueta identificativa</p> <p>→ Compruebe el cableado</p> <p>→ Compruebe los conectores</p> <p>→ Compruebe las platinas</p>	<p><b>Origines possibles :</b></p> <ul style="list-style-type: none"> <li>Défaut d'alimentation électrique</li> <li>Carte d'alimentation défectueuse</li> <li>Carte de commande défectueuse</li> </ul> <p>→ Vérifier la tension sur la plaque</p> <p>→ Vérifier le câblage interne et externe</p> <p>→ Vérifier les connexions enfichables</p> <p>→ Vérifier si les cartes ne présentent pas d'endommagements</p>	<p><b>Causas possíveis:</b></p> <ul style="list-style-type: none"> <li>erro na alimentação de tensão</li> <li>fonte de alimentação defeituosa</li> <li>placa de comando defeituosa</li> </ul> <p>→ ver na placa indicadora a tensão correcta</p> <p>→ verificar cablagem externa e interna</p> <p>→ verificar conexão da ficha/cabo em fita</p> <p>→ verificar se as placas apresentam quaisquer danos</p>
<p><b>Posibles causas:</b></p> <ul style="list-style-type: none"> <li>la tubería de la entrada y/o la tubería de la salida están obstruidas</li> <li>desgaste</li> <li>la platina de pilotaje está defectuosa</li> <li>la válvula de pilotaje está defectuosa</li> <li>la red no tiene la presión mínima</li> </ul> <p>→ Controle la tuberías</p> <p>→ Cambie las piezas de desgaste</p> <p>→ Compruebe si puede oír la válvula actuando (pulse el interruptor „TEST“ varias veces)</p> <p>→ Compruebe las platinas</p> <p>→ Compruebe la presión de trabajo, si es necesario utilizar los ECO-DRAIN especiales para baja presión o para vacío.</p>	<p><b>Origines possibles :</b></p> <ul style="list-style-type: none"> <li>Conduites d'arrivée et/ou d'évacuation obturées ou bouchées</li> <li>Usure (joints, noyau de l'électrovanne, membrane)</li> <li>Carte de commande défectueuse</li> <li>Electrovanne défectueuse</li> <li>Pression minimale non atteinte</li> <li>Pression maximale dépassée</li> </ul> <p>→ Contrôler l'arrivée et l'évacuation</p> <p>→ Remplacer les pièces d'usure</p> <p>→ Vérifier si l'ouverture de la soupape est perceptible (Presser plusieurs fois la touche Test)</p> <p>→ Vérifier si la carte ne présente pas d'endommagements</p> <p>→ Vérifier la pression de service. Au besoin, installer un purgeur "basse-pression", "systèmes sous vide" ou "haute-pression"</p>	<p><b>Causas possíveis:</b></p> <ul style="list-style-type: none"> <li>tubo de afluência e/ou descarga fechado ou entupido</li> <li>desgaste</li> <li>placa de comando defeituosa</li> <li>válvula magnética defeituosa</li> <li>pressão inferior à pressão mínima necessária</li> </ul> <p>→ controlar tubos de afluência e descarga</p> <p>→ substituir peças de desgaste</p> <p>→ verificar audivelmente de a válvula se abre (premir repetidamente o botão de teste)</p> <p>→ verificar se as placas apresentam quaisquer danos</p> <p>→ assegurar pressão mínima ou instalar um BEKOMAT de baixa pressão ou de vácuo.</p>
<p><b>Posibles causas:</b></p> <ul style="list-style-type: none"> <li>la tubería de la entrada no tiene pendiente descendente constante</li> <li>hay demasiada cantidad de condensado</li> <li>el sensor está muy sucio</li> <li>la red no tiene la presión mínima</li> </ul> <p>→ instale la tubería con pendiente descendente constante</p> <p>→ instale una tubería de compensación</p> <p>→ limpie el tubo del sensor</p>	<p><b>Origines possibles :</b></p> <ul style="list-style-type: none"> <li>Conduite d'arrivée avec pente insuffisante, section insuffisante</li> <li>Trop de condensat produit</li> <li>Tube de sonde fortement encrassé</li> </ul> <p>→ Réaliser l'arrivée avec une pente</p> <p>→ Installer une conduite d'équilibrage d'air</p> <p>→ Nettoyer le tube de sonde</p>	<p><b>Causas possíveis:</b></p> <ul style="list-style-type: none"> <li>tubo adutor sem declive suficiente</li> <li>quantidade excessiva de condensado</li> <li>sensor extremamente sujo</li> </ul> <p>→ instalar tubo com declive adequado</p> <p>→ instalar um tubo de equilíbrio</p> <p>→ limpar o sensor</p>
<p><b>Posibles causas:</b></p> <ul style="list-style-type: none"> <li>los conductos de pilotaje estan obstruidos</li> <li>desgaste</li> </ul> <p>→ limpie todo el módulo de la válvula</p> <p>→ cambie las piezas de desgaste</p> <p>→ limpie el tubo sensor</p>	<p><b>Origines possibles :</b></p> <ul style="list-style-type: none"> <li>Conduite d'équilibrage d'air bouchée</li> <li>Usure (joints, noyau de l'électrovanne, membrane)</li> </ul> <p>→ Effectuer un nettoyage complet de l'ensemble électrovanne</p> <p>→ Remplacer les pièces d'usure</p> <p>→ Nettoyer le tube sonde</p>	<p><b>Causas possíveis:</b></p> <ul style="list-style-type: none"> <li>tubo de controle de ar entupido</li> <li>desgaste</li> </ul> <p>→ limpar a unidade completa da válvula</p> <p>→ substituir peças de desgaste</p> <p>→ limpar sensor</p>

**ECO-DRAIN 21**

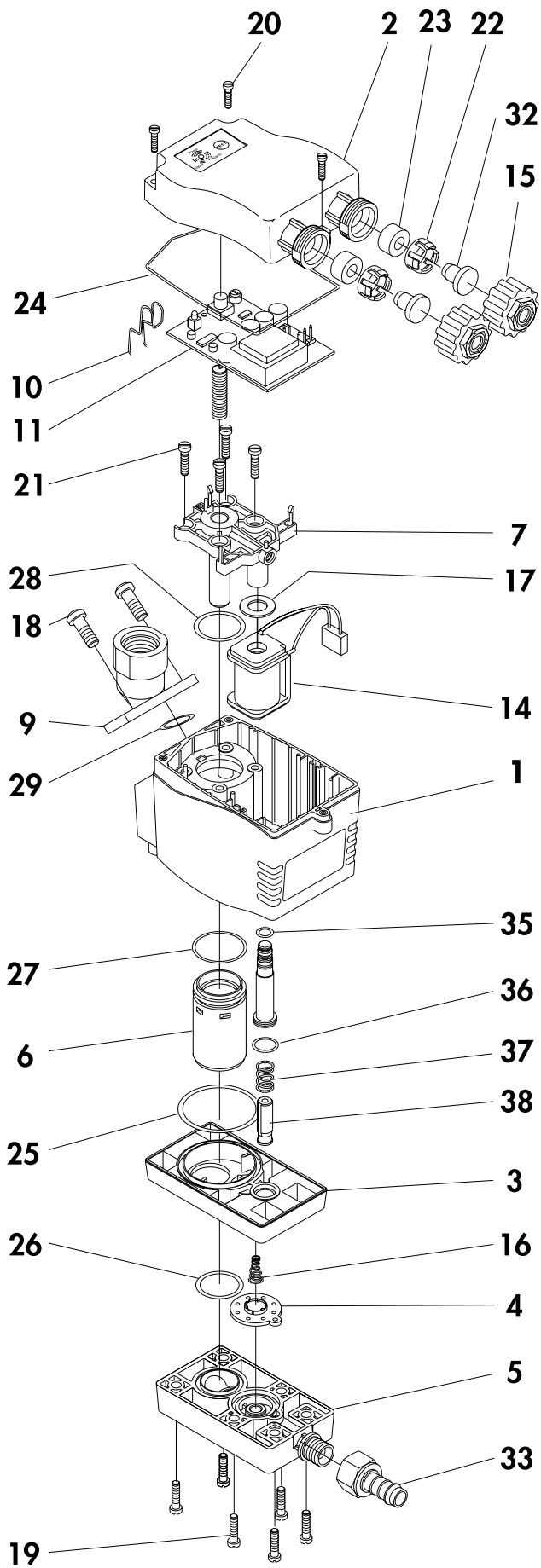

**ECO-DRAIN 21 PLUS**

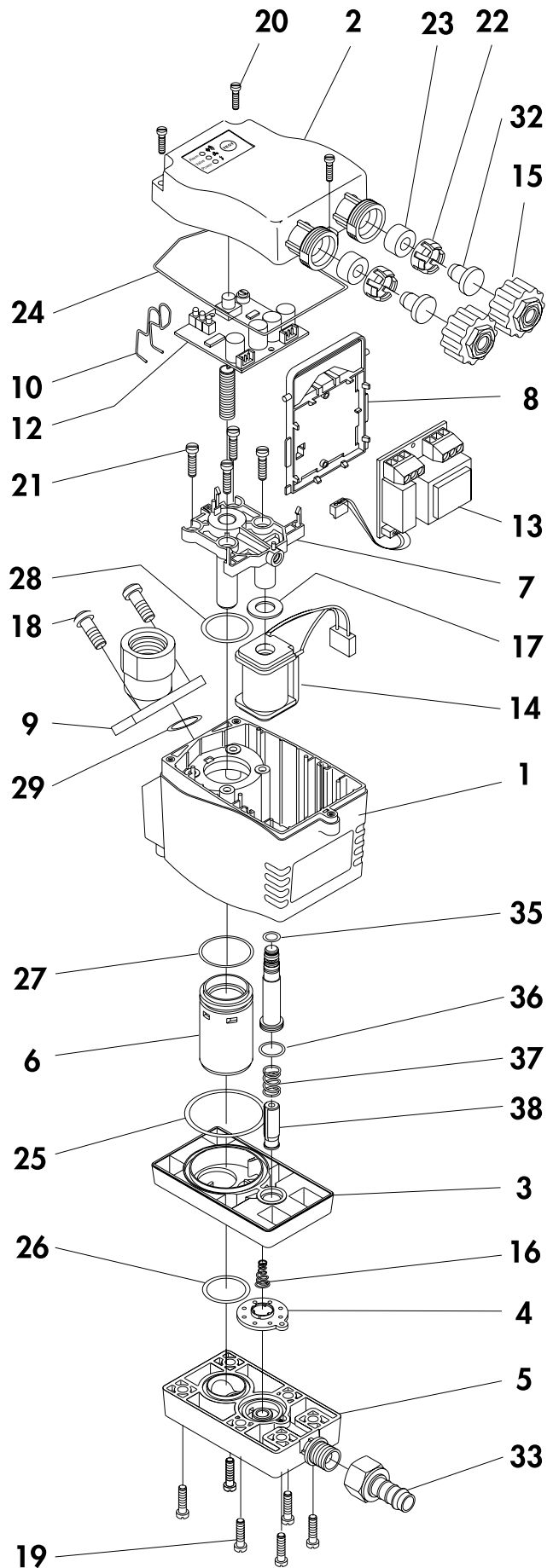

<b>english</b>	<b>español</b>	<b>français</b>	<b>português</b>
1 Housing	1 Carcasa	1 Boîtier	1 Caixa
2 Housing top	2 Tapa superior	2 Partie sup. boîtier	2 Tampa da caixa
3 Diaphragm cap	3 Tapa de membrana	3 Couvercle de membrane	3 Tampa do diafragma
4 Diaphragm	4 Membrana	4 Membrane	4 Diafragma
5 Diaphragm seat	5 Asiento de membrana	5 Siège membrane	5 Assento do diafragma
6 Earthing tube	6 Tubo toma tierra	6 Tupe de masse	6 Tubo de ligação à terra
7 Sensor tube	7 Tubo sensor	7 Tube de sonde	7 Sensor
8 Board holder	8 Soporte para platina	8 Support de carte	8 Receptáculo da placa
9 Elbow adaptor	9 Adaptador angular	9 Adaptateur orientable	9 Adaptador orientável
10 Contact spring	10 Muelle contactor	10 Ressort de contact	10 Contacto
11 Electronic PCB	11 Platina	11 Carte électronique	11 Placa electrónica
12 Control PCB	12 Platina de pilotaje	12 Carte de commande	12 Placa de comando
13 Power supply board	13 Platina fuente de alimentación	13 Carte d'alimentation	13 Placa de alimentação
14 Solenoid valve	14 Electroválvula	14 Electrovanne	14 Válvula magnética
15 Union nut	15 Tuerca loca	15 Ecrou presse-étoupe	15 Porca de capa
16 Spring for diaphragm	16 Muelle para la membrana	16 Ecrou presse-étoupe	16 Mola de pressão para diafragma
17 Washer	17 Disco	17 Rondelle	17 Argola ondulada
18 Pan head srew M6 x 16	18 Tornillo M6 x 16	18 Vis à tête cyl. M6x16	18 Parafuso M6x16
19 Pan head srew M5 x 16	19 Tornillo M5 x 16	19 Vis à tête cyl. M5x16	19 Parafuso M5x16
20 Pan head srew M3 x 10	20 Tornillo M3 x 16	20 Vis à tête cyl. M3x10	20 Parafuso M3x16
21 Self-tappingscrew Ø 4 x 16	21 Tornillo autobloqueante diá. Ø 4 x 16	21 Vis autotaraudeuse Ø 4 x 16	21 Parafuso autobloqueante Ø 4 x 16
22 Clamping fixture for PG11	22 Brida para PG11	22 Cage serre-câble PG11	22 Capa de aperto para PG11
23 Sealing ring for PG11 di = 7,5	23 Junta para PG11 di = 7,5	23 Bague d'étanchéité PG11 di = 7,5	23 Anel de vedação PG11 di = 7,5
24 Sealing of cover	24 Junta para tapa superior	24 Joint deboîtier	24 Vedação da tampa
25 O-ring 38 x 2	25 Junta tórica 38 x 2	25 Joint torique 38 x 2	25 Anel em „o“ 38 x 2
26 O-ring 20,35 x 1,78	26 Junta tórica 20,35 x 1,78	26 Joint torique 20,35 x 1,78	26 Anel em „o“ 20,35x1,78
27 O-ring 25,12 x 1,78	27 Junta tórica 25,12 x 1,78	27 Joint torique 25,12 x 1,78	27 Anel em „o“ 25,12x1,78
28 O-ring 19 x 2	28 Junta tórica 19 x 2	28 Joint torique 19 x 2	28 Anel em „o“ 19 x 2
29 O-ring 14 x 1,78	29 Junta tórica 14 x 1,78	29 Joint torique 14 x 1,78	29 Anel em „o“ 14 x 1,78
32 Vent plug for PG16	32 Tapón para PG16	32 Bague d'étanchéité PG16	32 Bujão de vedação para PG 16
33 Hose connector complete Ø 8 x 23	33 Machón completo para tubo diá.. Ø 8 x 23	33 Embout flexible complet Ø 8 x 23	33 Conector de tubo de borracha, completo Ø 8 x 23
35 O-ring 4,5 x 1,5	35 Junta tórica 4,5 x 1,5	35 Joint torique 10 x 1	35 Anel em „o“ 4,5 x 1,5
36 O-ring 10 x 1	36 Junta tóricas 10 x 1	36 Joint torique	36 Anel em „o“ 10 x 1
37 Pressure spring for valve core	37 Muella para el núcleo de la electroválvula	37 Ressort noyau de vanne	37 Mola de pressão para núcleo de válvula
38 Valve core	38 Núcleo para la electroválvula	38 Noyau de vanne	38 Núcleo de válvula

<b>Spare part kits • Recambios Kits de pièces de rechange • Kits de peças sobressalentes</b>		<b>english</b>
<b>ECO-DRAIN 21</b>		
<b>order ref. • Referencia Nº de com. • N.º de encom.</b>	<b>content • Contenido • contenu • conteúdo</b>	<b>Available sets of spare parts</b>
AN825200	4, 16, 25, 26, 29, 36, 37, 38	Set of wearing parts
AN825210	24, 25, 26, 27, 28, 29, 35, 36	Set of seals
AN825220	3, 4, 5, 16, 19, 25, 26, 33	Diaphragm seat
AN825230	10, 11	Electronic PCB (230 Vac)
AN825240	10, 11	Electronic PCB (110 Vac)
<b>ECO-DRAIN 21 PLUS</b>		
<b>order ref. • Referencia Nº de com. • N.º de encom.</b>	<b>content • Contenido • contenu • conteúdo</b>	<b>Available sets of spare parts</b>
AN825200	4, 16, 25, 26, 29, 36, 37, 38	Set of wearing parts
AN825210	24, 25, 26, 27, 28, 29, 35, 36	Set of seals
AN825220	3, 4, 5, 16, 19, 25, 26, 33	Diaphragm seats
AN825250	10, 12	PCB „control“
AN825260	8, 13	PCB „power supply“ (230 Vac)
AN825270	8, 13	PCB „power supply“ (110 Vac)
XE KA21 206	8, 13	PCB „power supply“ (24 Vac)
XE KA21 207	8, 13	PCB „power supply“ (24 Vdc)
XE KA21 214	8, 13	PCB „power supply“ (230 Vac) incl. external test connection
XE KA21 215	8, 13	PCB „power supply“ (110 Vac) incl. external test connection
XE KA21 216	8, 13	PCB „power supply“ (24 Vac) incl. external test connection
XE KA21 217	8, 13	PCB „power supply“ (24 Vdc) incl. external test connection



<b>español</b>	<b>français</b>	<b>português</b>
<b>Recambios disponibles</b>	<b>Kits de pièces de rechange disponibles</b>	<b>Kits disponíveis de peças sobressalentes</b>
<p>Juego de piezas de desgaste</p> <p>Juego de juntas</p> <p>Asiento de la membrana completo</p> <p>Platina (230 Vca)</p> <p>Platina (110 Vca)</p>	<p>Kit de pièces d'usure</p> <p>Jeu de joints d'étanchéité</p> <p>Siège de la membrane</p> <p>Carte électronique (230 Vac)</p> <p>Carte électronique (110 Vac)</p>	<p>Kit de peças de desgaste</p> <p>Kit de vedantes</p> <p>Assento do diafragma completo</p> <p>Placa eletrônica (230 Vac)</p> <p>Placa eletrônica (110 Vac)</p>
<b>Recambios disponibles</b>	<b>Kits de pièces de rechange disponibles</b>	<b>Kits disponíveis de peças sobressalentes</b>
<p>Juego de piezas de desgaste</p> <p>Juego de juntas</p> <p>Asiento de la membrana completo</p> <p>Platina de pilotaje</p> <p>Platina de alimentación (230 Vac)</p> <p>Platina de alimentación (110 Vac)</p> <p>Platina de alimentación (24 Vac)</p> <p>Platina de alimentación (24 Vdc)</p> <p>Platina de alimentación (230 Vac) con conexión externa</p> <p>Platina de alimentación (110 Vac) con conexión externa</p> <p>Platina de alimentación (24 Vac) con conexión externa</p> <p>Platina de alimentación (24 Vdc) con conexión externa</p>	<p>Kit de pièces d'usure</p> <p>Jeu de joints d'étanchéité</p> <p>Siège de la membrane</p> <p>Carte "Commande"</p> <p>Carte "Alim." (230 Vac)</p> <p>Carte "Alim." (110 Vac)</p> <p>Carte "Alim." (24 Vac)</p> <p>Carte "Alim." (24 Vdc)</p> <p>Carte "Alim." (230 Vac) avec raccord bouton test externe</p> <p>Carte "Alim." (110 Vac) avec raccord bouton test externe</p> <p>Carte "Alim." (24 Vac) avec raccord bouton test externe</p> <p>Carte "Alim." (24 Vdc) avec raccord bouton test externe</p>	<p>Kit de peças de desgaste</p> <p>Kit de vedantes</p> <p>Assento do diafragma, completo</p> <p>Placa "comando"</p> <p>Placa "alimentação" (230 Vac)</p> <p>Placa "alimentação" (110 vac)</p> <p>Placa "alimentação" (24 Vac)</p> <p>Placa "alimentação"(24 Vdc)</p> <p>Placa "alimentação" (230 Vac) com conexão externa de teste</p> <p>Placa "alimentação" (110 Vac) com conexão externa de teste</p> <p>Placa "alimentação" (24 Vac) com conexão externa de teste</p> <p>Placa "alimentação" (24 Vdc) com conexão externa de teste</p>

## **ARGENTINA**

Kaeser Compresores de Argentina, S.R.L.  
Av.Crisólogo Larralde 1197 (Ruta 197)  
B1648GJA - Tigre, Rep. Argentina  
Tel: (11) 5681-8097 • Fax: (11) 5681-8037  
E-mail: kaeserar@kaeser.com.ar

## **BRASIL**

Kaeser Compresores do Brasil, Ltda.  
Rua Marcilio Dias 148  
CEP 04764-080, Sao Paulo, SP  
Tel: (011) 4731-0707 • Fax: (011) 4731-0909  
E-mail: kaeserbr@kaeser.com.br

## **CANADA**

Kaeser Compressors, Inc.  
3517 Grande Alee Blvd.  
Boisbriand, Quebec J7H 1H5  
Tel: (450) 971-1414 • Fax: (450) 971-1415  
E-mail: info.canada@kaeser.com

## **CHILE**

Kaeser Compresores de Chile, Ltda.  
Cerro Portezuelo 9817-A  
Quilicura - Santiago  
Tel: (2) 747-1446 • Fax: (2) 747-1425  
E-mail: kaeserch@kaeser.ltda.cl

## **COLOMBIA**

Kaeser Compresores de Colombia, S.A.  
Carrera 63 No. 16-48  
Santafé de Bogotá, D.C.  
Tel: (1) 417-6970 • Fax: (1) 417-6980  
E-mail: kaeser@col1telecom.com.co

## **MEXICO**

Kaeser Compresores S.A. de C.V.  
Calle 2 No. 111 E y F  
Parque Industrial Jurica  
76100 Querétaro, Qro  
Tel: (4) 218-6448 • Fax: (4) 218-6449  
E-mail: kaesermex@acnet.net

## **USA**

Kaeser Compressors, Inc.  
P.O. Box 946  
Fredericksburg, VA 22404  
Tel: (540) 898-5500 • Fax: (540) 898-5520  
E-mail: kaeser2@kaeser.com  
www.kaeser.com