

SERVICE MANUAL

USE

Refrigerated Dryer

Model: TD 61

GL-Nr.: 1_8035_10010-00 01

Serial No.:

Table of Contents

1	Technical Specification	1 – 1
1.1	Refrigerated Dryer	1 – 1
1.2	Compressed Air System	1 – 1
1.3	Refrigerant System	1 – 1
1.4	Installation Requirements	1 – 1
1.5	Connections	1 – 1
1.6	Electrical Connection	1 – 2
1.7	Settings	1 – 2
1.8	Designation	1 – 2
1.9	Dimensional Diagram	1 – 2
2	Safety Regulations	2 – 4
2.1	Explanation of Symbols and References	2 – 4
2.2	General Safety Instructions	2 – 4
2.3	Refrigerant	2 – 5
2.4	First Aid after Contact with Refrigerant	2 – 6
2.5	Spare Parts	2 – 6
2.6	Environmental Protection	2 – 6
3	General	3 – 7
3.1	Proper use	3 – 7
3.2	Improper use	3 – 7
3.3	Copyright	3 – 7
4	Transport	4 – 8
4.1	Transport Instructions	4 – 8
4.2	Packaging	4 – 8
4.3	Temporary Storage	4 – 8
5	Construction and Operation	5 – 9
5.1	Construction	5 – 9
5.2	Functional Description	5 – 9
5.3	Refrigerant Circulation	5 – 9
5.4	ECO–DRAIN	5 – 10
5.4.1	Condensate drainage	5 – 10
5.4.2	Function	5 – 10
5.4.3	Operational Status Indicator	5 – 10
5.4.4	Functional check	5 – 11
5.5	Component Identification	5 – 11
5.6	Pipe and Instrument Flow Chart (P & I Flow Chart)	5 – 11
6	Installation	6 – 14
6.1	Installation Requirements	6 – 14
6.2	Compressed Air Connection	6 – 15
6.3	Condensate Drain Connection	6 – 15
6.4	Electrical Connection	6 – 16
6.5	Voltless Contacts	6 – 16

Table of Contents

7	Preparation For Initial Start Up	7 – 17
7.1	Points to be Observed before Start Up	7 – 17
7.2	Points to be Observed before Switching On:	7 – 17
7.3	Ready for Operation	7 – 18
8	Operation	8 – 19
8.1	Instrument Panel	8 – 19
8.2	Starting the Refrigerated Dryer	8 – 20
8.3	Stopping the Refrigerated Dryer	8 – 21
8.4	Trouble shooting	8 – 21
8.4.1	Water in the compressed air system	8 – 22
8.4.2	High pressure losses via the refrigerated dryer	8 – 22
8.4.3	Pressure dew point too high	8 – 22
8.4.4	High compressed air losses	8 – 22
8.4.5	Red LED on the ECO–DRAIN housing flashes	8 – 23
8.4.6	The safety pressure switch shuts down the refrigerated dryer	8 – 23
9	Maintenance	9 – 24
9.1	Maintenance Instructions:	9 – 24
9.2	Regular Maintenance	9 – 24
9.2.1	General checks	9 – 25
9.2.2	Cleaning the condenser	9 – 25
9.2.3	Check the condensate outlet daily as follows:	9 – 25
9.2.4	Check ECO–DRAIN for proper operation monthly, as follows:	9 – 25
9.2.5	Cleaning the ECO–DRAIN	9 – 26
10	Spare Parts and After Sales Service	10 – 29
11	Appendix	11 – 30
11.1	Wiring Diagram	11 – 30
11.2	Maintenance Schedule	11 – 40

1 Technical Specification

1.1 Refrigerated Dryer

Model	TD 61
Condensate volume under nominal conditions*	71 oz/h
Weight	632 lbs
Cooling air volume	1880 cfm

Drawings:

P & I flow chart FKTTD51-00016.00
(Pipework and instrument flow chart)

Electrical diagram STD-U0915.00

Dimensional drawing T 9007.2

By-pass piping 896383.0

* See chapter 1.2 for nominal conditions.

Max. rise (condensate drain discharge) 16.4 ft

Noise level to CAGI-Pneurop < 70 dB(A)
at 1 m distance (free sound field measurement)

1.2 Compressed Air System

Flow volume	240 scfm
Pressure drop	1.45 psid
Pressure dewpoint	35 °F
at 100 °F air inlet, 100 psig and 100 °F ambient temperature.	
Maximum gauge working pressure	230 psig

1.3 Refrigerant System

Refrigerant	R 134a
Maximum quantity	3.57 lbs
Permissible gauge working pressure	260 psig

1.4 Installation Requirements

Max. elevation above sea level of installation	3000 ft.
(for all elevations above please contact authorized KAESER distributor)	
Min. ambient temperature	40 °F
Max. ambient temperature	110 °F
Maximum compressed air inlet temperature	130 °F

1.5 Connections

Compressed air outlet	1 1/2 NPT
Condensate drain connection (hose connection)	3/8
Service connection (Schrader valve)	7/16 UNF

Technical Specification

1.6 Electrical Connection

Main voltage	460 V ± 10 % 3-phase
Full load current, FLA	3 A
Frequency	60 Hz
Recommended main disconnect fuses (Dual element or time-delay)	6 A
Recommended power supply cable (Cu multi-stranded) cross-section	14 AWG

Attention!

Maximum dual element time-delay fuses are selected according to 1996 N.E.C. Article 240-6, 430-52 and Tables 430-148 & 150.

Select multi-strand copper core wire at 40° C ambient temperature according to 1996 N.E.C. 110-14(c), 220-3, 310-15, Table 310-16, 430-6, 430-22 and Tables 430-148 & 150.

* See chapter 1.2 for nominal conditions.

1.7 Settings

Safety pressure switch (refrigerant)

switching point (fixed)

P_{OFF} 265 psi

Thermostat

regulates pressure dewpoint to approx. 35 °F

1.8 Designation

The nameplate of the refrigerated dryer is located on the front left below the cooling air inlet (see chapter 10 for an illustration of the nameplate).

1.9 Dimensional Diagram

(see next page)

Technical Specification

KAESER
COMPRESSORS

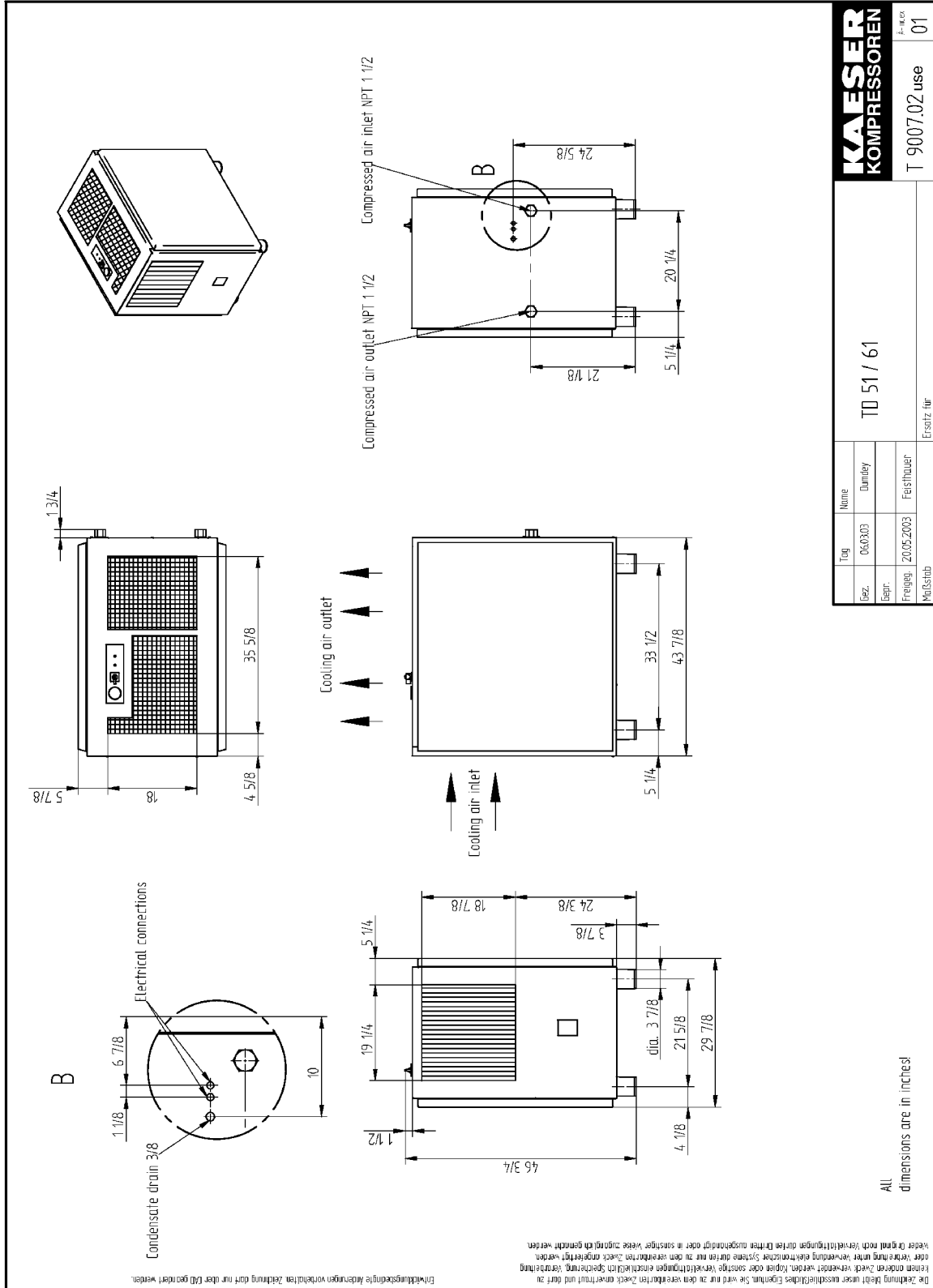

KAESER		KOMPRESSOREN		Ersatz für		01	
TD 51 / 61		T 9007.02 use					
Tag	Name	Gez.	Dummy	Freigeig.	20.05.2003	Feisthauer	
06.03.03		Bepr.				Mitsub.	

All dimensions are in inches!

Entwicklungsänderungen vorbehalten. Zeichnung darf nur über CAD geändert werden.
 Die Zeichnung bleibt unser geistiges Eigentum. Sie wird nur zu dem vereinbarten Zweck erstellt und darf zu keinem anderen Zweck verwendet werden. Kopien oder sonstige Vervielfältigungen einzellicher Speicher, Verordnungen oder Verträge sind nur zu dem vereinbarten Zweck angefertigt zu werden.
 Weder Original noch Vervielfältigungen dürfen Dritten ausgenommen oder in sonstiger Weise zugänglich gemacht werden.

2 Safety Regulations

Read this service manual very carefully and observe all cautionary references before the initial start of this refrigerated dryer and before carrying out any maintenance on the unit.

2.1 Explanation of Symbols and References



This symbol is placed before all safety references where there is danger to life and limb. It is especially important that any associated instructions are followed explicitly and that extreme care is taken when performing the indicated task(s). For their own protection, inform all other users of these safety rules. Observe general safety and accident prevention regulations as well as the safety rules laid down in this service manual.

Attention!

This symbol is placed by text where considerable attention must be paid to recommendations, regulations, references and correct sequence so that damage and/or destruction of the compressor and/or other equipment is prevented.



This symbol identifies environmental care measures.



This symbol indicates operations to be carried out by the operator or service technician.

- This bullet identifies listings.

2.2 General Safety Instructions



Work on power driven systems may only be carried out by trained or instructed personnel or by specialized personnel.

Work on the electrical equipment of the refrigerated dryer may only be carried out by a qualified electrician or trained personnel under the supervision of a qualified electrician according to the NEC and any applicable local codes.

Work on the refrigeration system may only be carried out by a certified refrigeration technician (according to 40CFR Part 82).

Further points to be observed:

- No open flame or sparks at the point of installation.
- The maximum ambient temperature may not be exceeded (see chapter 1.4), otherwise special measures must be agreed between the manufacturer and the user.
- This machine is not explosion-proof.
It may not be operated in areas in which specific requirements with regard to explosion protection are applied.

Attention!

The refrigerated dryer contains live electrical components.



Prior to working on electrical systems of the compressor always perform the following steps in the sequence shown.

1. Lock the main disconnect in the "off" position in accordance with applicable lock out/ tag out procedures (example: OSHA CFR 29 § 1910.147) to ensure the compressor does not restart.
2. Ensure the package cannot be switched on again
3. Check that no voltage is present
4. Lock the isolation shut-off valve in the "closed" position and vent all compressed air trapped between the compressor and the isolation shut-off valve in accordance with applicable lock out/ tag out procedures (example: OSHA CFR 29 § 1910.147).



The refrigerated dryer contains systems subject to high pressures. Before any maintenance work is carried out, vent and shut off all pipe-work under pressure.



Do not weld or braze on any pressurized components (e.g., pipes, tanks, fittings) or make any modifications that require heat treatment.

Attention!

Safety devices may not be modified or deactivated.

Signs and labels of reference may not be removed or rendered unreadable.

Attention!

Any alterations or reconstruction carried out without the prior written authorization of KAESER COMPRESSORS Inc. will invalidate the warranty.

2.3 Refrigerant



Initial startup of and maintenance work on the refrigerant circuit may only be carried out by persons who have been trained in the safety concepts of refrigeration engineering.



Escaping compressed air and/or refrigerant can cause injury, frostbite, burns and lead to damage to the unit. Safety data sheets explaining how to deal with refrigerant are available from KAESER COMPRESSORS Inc.



The refrigerant contained in the refrigerating system may not be vented to the open air. Always use a refrigerant recovery system when working on the refrigerant circulation. Dispose of unusable refrigerant according to environmental regulations!

Attention!

Any alterations or reconstruction carried out without the prior written authorization of KAESER COMPRESSORS Inc. will invalidate the warranty.

2.4 First Aid after Contact with Refrigerant

General: Remove damp clothing.

Inhalation:

- ☞ Remove victim to the fresh air.
Obtain medical attention in the case of breathing difficulties or nervous symptoms.

Skin:

- ☞ Rinse area with plenty of warm water.
Treat frostbite the same as burns. Obtain medical attention if pain persists or skin reddens.

Eyes:

- ☞ Open eyelids wide to allow product to evaporate.
Rinse immediately with open eyelids and plenty of running water for at least 10 minutes and seek medical advice if pain persists.

2.5 Spare Parts

The use of KAESER original parts guarantees safe and reliable operation of the refrigerated dryer.

2.6 Environmental Protection

Condensate drainage



The condensate accumulated during the drying of compressed air must be removed via a suitable drainage system, collected in special canisters and disposed of according to federal and local environmental regulations.

Maintenance materials/wear items/replacement parts



Ensure that all wear items, maintenance and replacement parts accumulated during operation of the refrigerated dryer are disposed of according to environmental regulations.

3 General



The service manual must always be available for use at the location of the refrigerated dryer.

3.1 Proper use

The refrigerated dryer is intended solely for drying compressed air.

Any other use outside of this purpose is considered improper. The manufacturer cannot accept liability for any damage caused by improper use; the user alone is liable for any risks incurred.

Proper use of the dryer includes compliance with the installation, removal, servicing, operation and maintenance instructions as specified by the manufacturer.

3.2 Improper use



Never direct compressed air toward persons. Compressed air is a concentrated form of energy and as such is dangerous to life.

3.3 Copyright

© KAESER COMPRESSORS, INC.

All rights reserved. No part of this manual may be reproduced in any form without permission of KAESER COMPRESSORS, INC.

4 Transport

4.1 Transport Instructions

Attention!

Under no circumstances lift the refrigerated dryer with the compressed air inlet and outlet connections or lay the refrigerated dryer on its side. Serious damage can result from such treatment of the refrigerated dryer.

To prevent damage to the panelling of the refrigerated dryer always use a jack lift or a forklift truck for transport.

- ☞ Always mount the refrigerated dryer on a suitable transporting medium (pallet or wooden base) during transport.

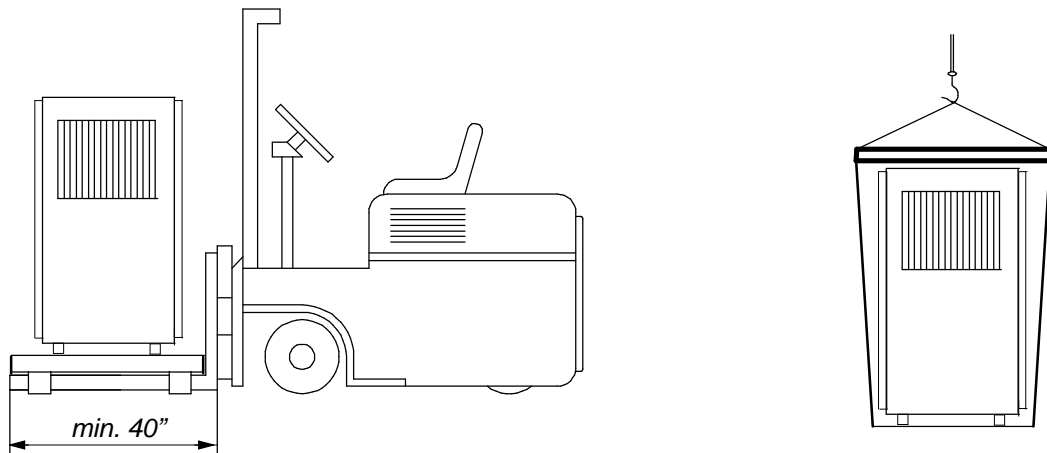
**Attention!**

Do not exert any side forces on the refrigerated dryer with lifting equipment.

4.2 Packaging

The transport route decides the type of packaging.



Dispose of the packaging according to environmental regulations and recycle where possible.

Overland

The machine should be protected from mechanical damage by a sturdy crate and plastic sheeting used to keep moisture out.

If the machine is to remain packed for a lengthy period, then the instructions in chapter "should be followed.

By sea or air

Special packing instructions can be obtained from KAESER Service.

4.3 Temporary Storage

Store the refrigerated dryer in an enclosed space, regardless of whether it is packaged or not.

The storage temperature should not fall below -13°F and not rise above 140°F .

Attention!

Before initial start, wait until the temperature of the refrigerated dryer has adapted to the ambient temperature.

5 Construction and Operation

Items referred to in () correspond with the items in the Pipe and Instrument Flow Diagram (see chapter 5.6).

5.1 Construction

The main component of the refrigerated dryer comprises a combined heat exchanger (heat transmitter). It consists of the two following main groups:

1st. stage: air to air heat exchanger (1)

2nd. stage: air to refrigerant heat exchanger (2)

A condensate separating system (3) is fitted in series with the heat exchanger.

A safety pressure switch (9) is fitted in the refrigerant circulation system as a protection against excessive pressure.

A thermal overload switch protects the refrigerant compressor (11) against current overloads and high temperatures.

The refrigerant circulation is automatically regulated with a thermostat (13).

5.2 Functional Description

The dried compressed air is then rewarmed by flowing through the air to air heat exchanger (1) before leaving the refrigerated dryer.

The warm compressed air of high humidity entering the unit is initially cooled in the air to air heat exchanger (1) through heat exchange with the cooled compressed air leaving the unit.

The moisture precipitated in the air to air heat exchanger is drained via an automatic condensate drain (5).

Further cooling occurs in the air to refrigerant heat exchanger (2), connected in series with the air to air heat exchanger through the action of expanding, gassing refrigerant. This action causes the humid components of the compressed air to condense out when the pressure dewpoint is undercut.

The condensate separator, (3) connected in series, separates the condensed water and oil droplets, together with coarse dirt particles, from the compressed air. This condensate is removed from the system by an automatic condensate drain (5).

The cooling action of the refrigerated dryer causes the condensation and subsequent separation of the humid content of the compressed air.

The refrigerant compressor (11) is switched off by a thermostat if the refrigeration demand sinks and switched on again when the demand rises. Considerable savings in energy are possible with this principle of operation.

5.3 Refrigerant Circulation

The dryer is able to cool the compressed air by using a refrigeration system not unlike a typical home refrigerator. Cooling is achieved by transferring heat from the compressed air to the refrigerant by vaporizing (boiling) the refrigerant, thereby turning the refrigerant into a gas. A more complete description of this process is given below:

The refrigerant enters the hermetically sealed compressor (11) as a low pressure gas. The gas is compressed to a suitable pressure to ensure that the gas is nearly saturated. The high pressure refrigerant gas flows to the condenser (10) where heat is removed from the refrigerant. As the high pressure refrigerant gas is cooled, the refrigerant becomes a liquid.

The high pressure liquid is then forced through a capillary tube (7). By forcing the refrigerant through this restriction, the refrigerant becomes a low pressure liquid. The low pressure, liquid refrigerant enters the evaporator (2) where heat from the compressed air is transferred to the refrigerant. The added heat causes the refrigerant to boil and results in the refrigerant becoming a low pressure gas. This becomes an endless cycle which allows the refrigerant to simply remove heat from the compressed air and expel it to the ambient air.

5.4 ECO-DRAIN

5.4.1 Condensate drainage

Once the moisture has been condensed and collected, the liquid must be drained from the dryer. The ECO-DRAIN provides a reliable means to remove the liquid without wasting compressed air.

5.4.2 Function

Any moisture that is condensed flows to a low point where it enters the drain trap at the inlet opening (1). The moisture is collected in the drain trap chamber (2). Once the chamber is full, the electronic sensor (3) energizes the electronic controller (7). The controller opens a small pilot port which allows the diaphragm valve (4) to open. As the liquid level drops, the electronic sensor closes the valve again before any compressed air can escape.

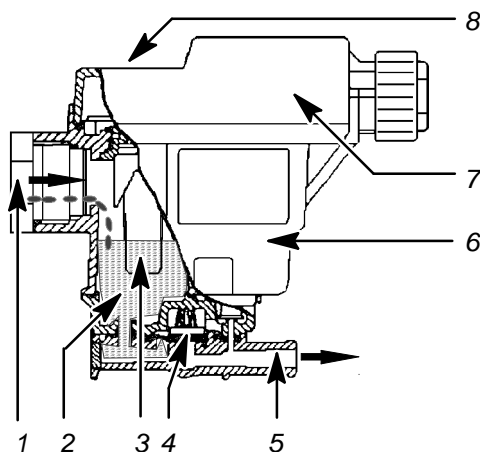

- 1 Inlet opening
- 2 Collector
- 3 Level detector
- 4 Diaphragm valve

- 5 Outlet line
- 6 Housing
- 7 Electronic control
- 8 Light-emitting diode

- If a fault occurs (e.g. overload), the valve cycles on and off continuously to clear the fault. The light-emitting diode flashes.

5.4.3 Operational Status Indicator

The operational status of the condensate drain is indicated by a red LED (8) on the housing of the ECO-DRAIN. The LED will indicate one of the following conditions:

- 1 LED on permanently:
the drain is operational
- 2 LED extinguishes for a short period:
the drain is discharging moisture
- 3 LED flashing continuously:
a fault exists

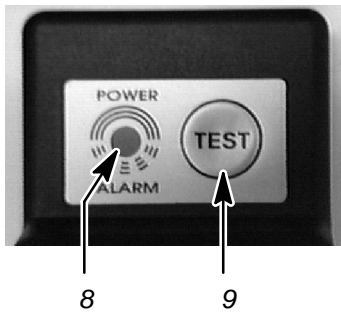

- 8 Operational status – light emitting diode
9 TEST pushbutton (condensate drain)

5.4.4 Functional check

Check the function of the ECO–DRAIN by pressing the TEST pushbutton (9). The ECO–DRAIN will switch to the discharge mode every 2 to 3 seconds as long as the button is depressed. The LED (8) flashes at the same interval.

5.5 Component Identification

Numbers in () correspond to those in the Pipe and Instrument Flow Chart. (P & I Flow Chart).

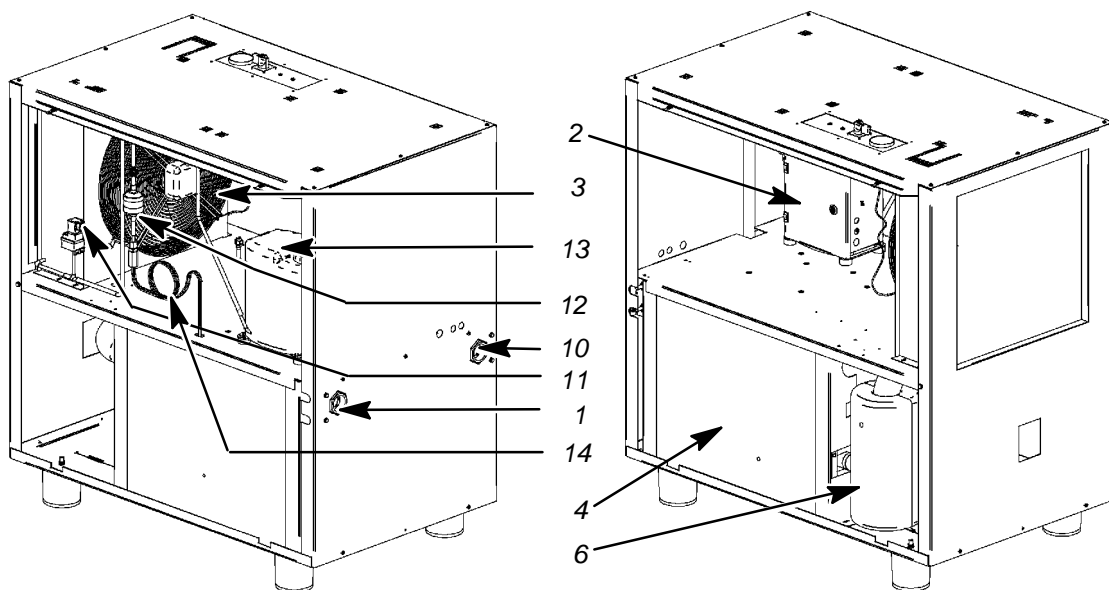

- | | |
|------------------------------|--------------------------------|
| 1 Compressed air outlet | 10 Compressed air inlet |
| 2 Control cubicle | 11 Safety pressure switch (9) |
| 3 Refrigerant liquefier (10) | 12 Filter dryer (8) |
| 4 Heat exchanger | 13 Refrigerant compressor (11) |
| 6 Condensate separator (3) | 14 Capillary tube (7) |

5.6 Pipe and Instrument Flow Chart (P & I Flow Chart)

(see following pages)

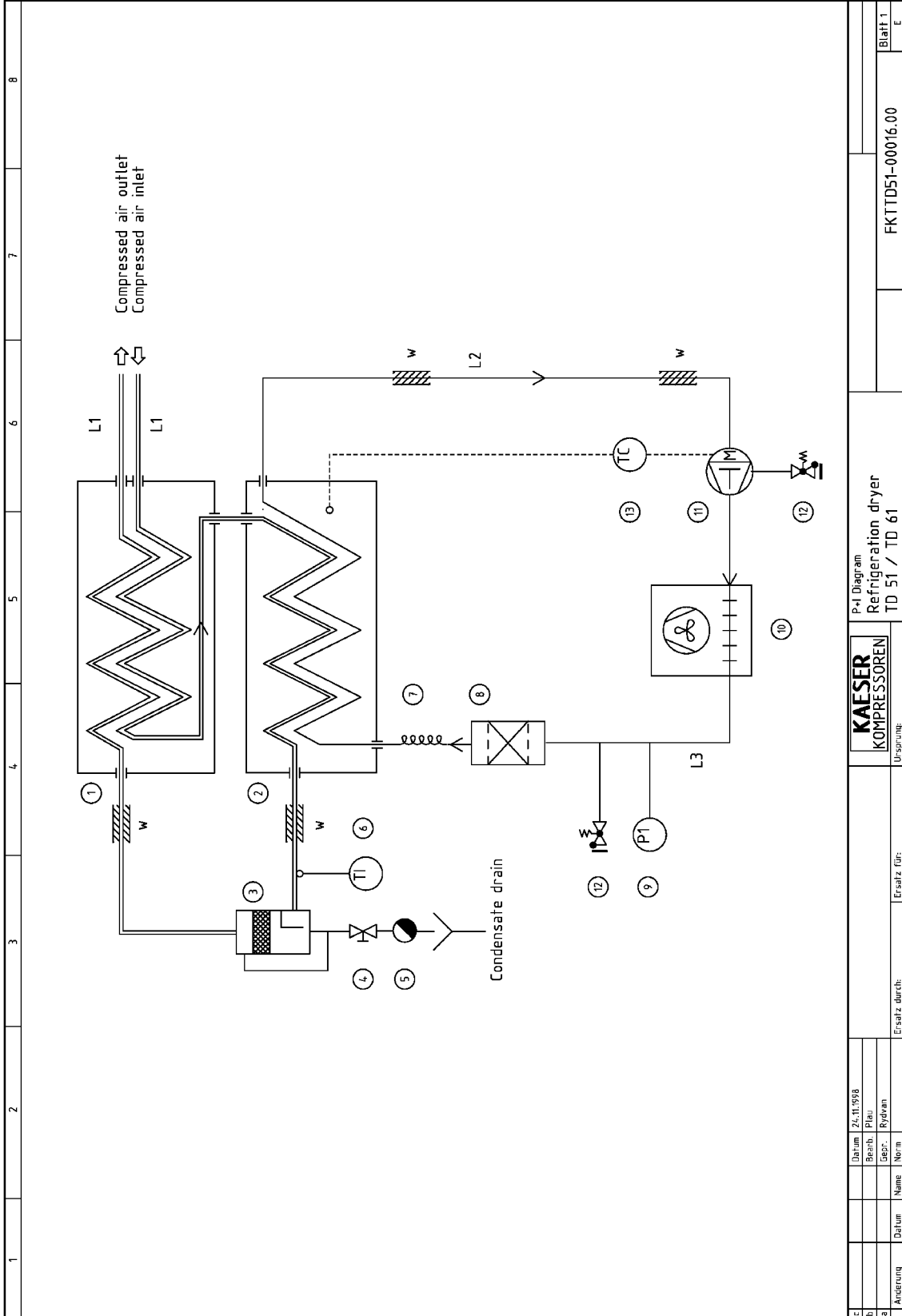

1	2	3	4	5	6	7	8																							
1	Air to air heat exchanger				} heat insulated																									
2	Air to refrigerant heat exchanger (Evaporator)																													
3	Condensate separator																													
4	Shut-off valve																													
5	Condensate drain																													
6	Pressure dew point indicator TI																													
7	Capillary tube (Refrigerant injection)																													
8	Filter dryer																													
9	Safety pressure switch																													
10	Refrigerant liquefier (air cooled condenser)																													
11	Refrigerant compressor (hermetic)																													
12	Service connection (Schrader valve)																													
13	Thermostat																													
Piping:																														
L1	CU-Pipe 54 x 2,0 DIN 1708																													
L2	CU-Pipe 12 x 1,0 DIN 1708																													
L3	CU-Pipe 8 x 1,0 DIN 1708																													
w	heat insulated																													
<table border="1"> <tr> <td>Änderung</td> <td>Datum</td> <td>Name</td> </tr> <tr> <td> </td> <td> </td> <td> </td> </tr> </table>		Änderung	Datum	Name				<table border="1"> <tr> <td>Erstellt durch:</td> <td>Erstellt für:</td> </tr> <tr> <td> </td> <td> </td> </tr> </table>		Erstellt durch:	Erstellt für:			<table border="1"> <tr> <td>Datum</td> <td>Zu: 11.09.08</td> </tr> <tr> <td>Beinh.</td> <td>Plan</td> </tr> <tr> <td>Erst.</td> <td>Reihen</td> </tr> </table>		Datum	Zu: 11.09.08	Beinh.	Plan	Erst.	Reihen	<table border="1"> <tr> <td colspan="2">P-I Diagram legend</td> </tr> <tr> <td colspan="2">Refrigeration dryer</td> </tr> <tr> <td colspan="2">TD 51 / TD 61</td> </tr> </table>		P-I Diagram legend		Refrigeration dryer		TD 51 / TD 61		FKTTD51-00016.00
Änderung	Datum	Name																												
Erstellt durch:	Erstellt für:																													
Datum	Zu: 11.09.08																													
Beinh.	Plan																													
Erst.	Reihen																													
P-I Diagram legend																														
Refrigeration dryer																														
TD 51 / TD 61																														
							Blatt z																							
							E																							

6 Installation

6.1 Installation Requirements

The refrigerated dryer must be installed in a dry and dust free space. To ensure adequate room for the maintenance of the refrigerated dryer, the minimum distances must be complied with (see following sketch).

Install the dryer on an even flat surface. Special foundations for the installation of the refrigerated dryer are not necessary.

See chapter 1.4 for the the ambient temperature and maximum height of the place of installation.

Attention!

To ensure adequate ventilation and air circulation, be sure to allow for the indicated minimum clearances at the cooling air inlet and exhaust.

The refrigerated dryer must not be installed in the air inlet and/or cooling air outlet area of a compressor package.
The compressed air to be dried and the ambient air in the compressor space may not contain any acid-forming or other aggressive materials.

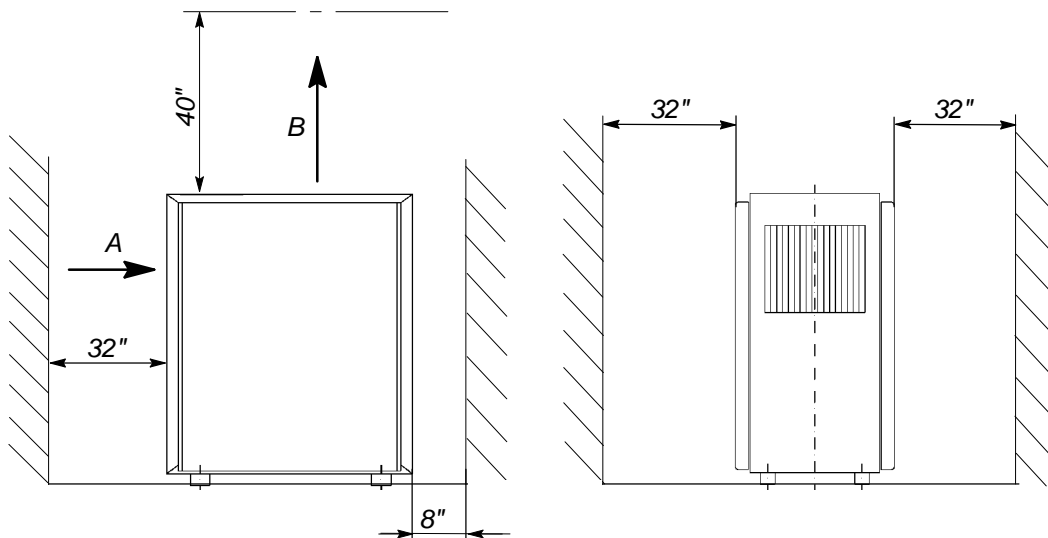

Measurements shown are minimum recommendations

A Cooling air inlet

B Cooling air outlet

Attention!

Installing of inlet and/or exhaust air ducting without prior written approval from of KAESER COMPRESSORS Inc. is not permitted.

6.2 Compressed Air Connection

Attention!

Use flexible connecting pipes at the compressed air inlet and discharge to ensure vibration isolation, prevent strain on piping connections and allow easy installation.
To avoid damage, do not overtighten the compressed air connections.

The refrigerated dryer is piped ready for operation.

Shut-off valves:

All power driven systems must be equipped with a main stop system for all forms of energy feed, the operation of which determines the start and stop of the energy supply to the system.

The compressed air inlet and outlet pipework must be provided with shut off arrangements (e.g. ball valves).

Bypass:

The compressed air inlet and outlet should be fitted with a bypass.

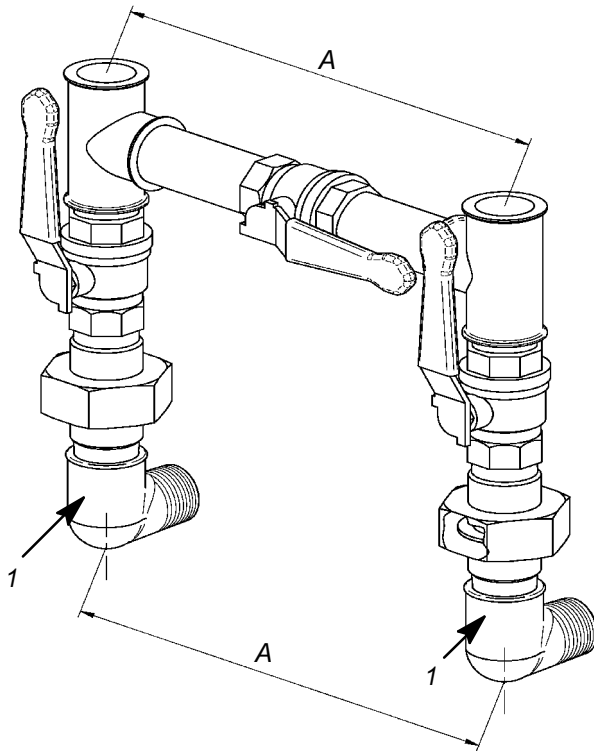
**Installation Instructions:**

- Seal the threads of the bypass fittings with sealing tape and assemble according to dimension (A); use optional elbow fittings (1), if necessary.

6.3 Condensate Drain Connection

A hose connection is provided for drainage of the condensate. See chapter 1.5 for the dimensions.

Use larger cross-sections for condensate lines longer than 16ft.

Attention!

Take care when fitting the condensate drainage hose that the condensate separated by the refrigeration dryer can flow without hindrance.

Attention!

If more than one ECO Drain is used, they must all be connected directly to the main condensate drainage line.



Direct the condensate separated by drying the compressed air via a hose into a suitable container and dispose of according to environmental care regulations.

6.4 Electrical Connection



The main power supply and overcurrent protection must be installed by a qualified electrician in accordance with NEC, OSHA and any applicable local codes.

For fuse and wire recommendations, see chapter 1.6.

The refrigerated dryer is delivered completely wired, ready for connection to the power supply. This connection must be made as detailed in the electrical diagram (see chapter 11.1). See the dimensional diagram (see chapter 1.9) for the position and size of the cable entry into the refrigerated dryer.

Attention!

Maximum dual element time–delay fuses are selected according to 1996 N.E.C. Article 240–6, 430–52 and Tables 430–148 & 150.

Select multi–strand copper core wire at 40° C ambient temperature according to 1996 N.E.C. 110–14(c), 220–3, 310–15, Table 310–16, 430–6, 430–22 and Tables 430–148 & 150.

Wire temperature rating:

1.25 x FLA (see chapter 1.6)	wire temperature rating	correction factor for 40° C
≤ 100A	60° C	0.82
> 100A	75° C	0.88

6.5 Voltless Contacts

The refrigerated dryer is provided with the following volt–free alarm contacts for connection to an external alarm reporting system:

- Message: "Refrigerant compressor ON"
- Message: "High pressure dewpoint "

7 Preparation For Initial Start Up

7.1 Points to be Observed before Start Up

Every refrigerated dryer is tested in the factory and carefully checked before shipment. The test run confirms that the refrigerated dryer conforms to the manufacturer's specifications and operates as designed.

However, independent of the checks made at the factory, the refrigerated dryer could be damaged during transport.

Therefore, the refrigerated dryer should be inspected for visible and hidden transport damage.

If damage is found, inform the carrier and the manufacturer immediately in writing.

Inspect the refrigerated dryer carefully during the first hours of operation for any possible malfunction.

Attention!

The internal components of the refrigerated dryer are factory adjusted for correct operation. Adjustments may not be made to these components without prior written consultation with KAESER Compressors Inc.

7.2 Points to be Observed before Switching On:



NON-OBSERVANCE OF THESE OR OTHER REFERENCES (WARNING; ATTENTION) CAN LEAD TO ACCIDENTS CAUSING INJURY TO PERSONNEL OR DAMAGE TO EQUIPMENT.

It is forbidden to operate the refrigeration dryer with the panelling removed because of the danger of injury to personnel.

- ☞ Remove all packaging materials, tools and transport securing devices on and in the refrigerated dryer.
- It is expected that the user employs safe working techniques when operating the refrigeration dryer and that all valid operating and safety provisions are followed.
- The operator of this refrigerated dryer unit is responsible for its safe working condition.
- The air in the compressor space and the compressed air to be dried may not contain any acid-forming or other aggressive matter.
- Do not connect the refrigerated dryer to a supply voltage different to that shown on the nameplate.
- Install the refrigerated dryer in a space that is not subject to freezing conditions. See chapter 1.4 for the minimum ambient temperature.
- Wait for the refrigerated dryer to warm up to the ambient temperature before putting into operation.



Carry out the following work only when the power supply is removed from the refrigerated dryer:

Check all screws on the electrical connections for tightness and tighten if necessary (carry out this check again after 50 operating hours).

7.3 Ready for Operation

Attention!

Do not start the refrigerated dryer until completing the following:

- The refrigerated dryer is installed according to the conditions stated in chapter 6.
- All electrical connections, air piping and condensate lines are correctly connected and properly tightened.
- The shut-off valves in the compressed air inlet and outlet lines are closed.
- The condensate drainage line is free of obstructions.
- The refrigerated dryer is supplied with the correct voltage supply.
- The by-pass in the compressed air line between input and output lines is closed.

Attention!

Start the refrigerated dryer for approximately 15 minutes before opening the shut-off valves in the compressed air inlet and outlet lines.

8 Operation

During operation of the refrigerated dryer, condensate is separated from the compressed air.



The condensate must be drained and collected in a suitable container. It must be disposed of according to Federal and local environmental codes.

☞ Collect the accumulated condensate in a container and dispose of properly.

8.1 Instrument Panel

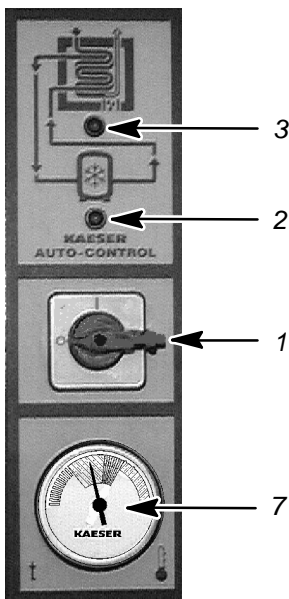

- 1 Main switch
- 2 Indicator – refrigerant compressor ON
- 3 Indicator – control voltage ON and thermal mass effective
- 7 Indicator – dew point

Operation

Explanation of the colored segment scale of the pressure dew point indication:
(suction pressure gauge)

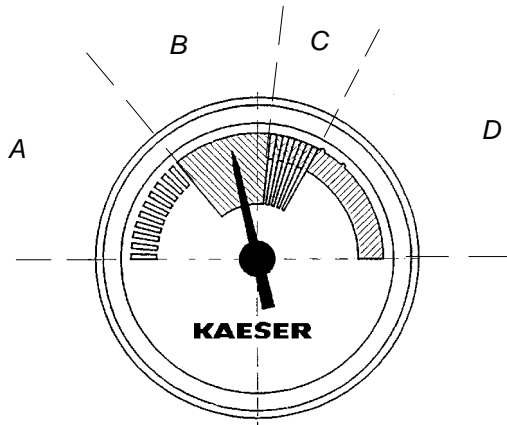

- **A**

Blue–white range (low suction pressure) results in too low a pressure dewpoint due to:

- Evaporator temperature too low (evaporator freeze–up)
- Dryer too large or very low air demand. Refer to chapter 1.4

- **B**

Green range (normal suction pressure) results in a normal pressure dew point.

- **C**

Green–red range (elevated suction pressure) results in increased pressure dew point to:

- High ambient temperature

- **D**

Red range (high suction pressure) results in too high a pressure dew point due to:

- Fault, see chapter 8.4.3 for help

8.2 Starting the Refrigerated Dryer

Attention!

Switch on the refrigerated dryer only if the conditions in chapter 7.3 “Ready for Operation” are fulfilled.

- ☞ Check the refrigerated dryer according to chapter 7.3.
- ☞ Remove the padlock provided for protection against “inadvertent switch–on” of switch (1).
- ☞ Rotate the switch (1) to “I” (ON).

The refrigeration dryer is now in operation, the control lamp (3) illuminates indicating power on.

Depending on the temperature in the air to refrigerant heat exchanger, the refrigerant compressor switches on after the refrigeration dryer is switched on. Simultaneously the control lamp (2) “Refrigerant Compressor ON” illuminates.

Operation



If the control lamp (2) does not extinguish after approximately 15 minutes then a fault is apparent (see chapter 8.4.3).

Attention!

Do not open the compressed air shut-off devices (inlet/outlet) until the control lamp (2) is extinguished.

- ☞ Open the shut-off valve of the compressed air inlet slowly (admission of the compressed air).
- ☞ Open the shut-off valve of the compressed air outlet slowly.

The compressed air system is now connected to the refrigerated dryer.

Attention!

Press RESET (8) if the safety pressure switch has shut down the refrigerated dryer.

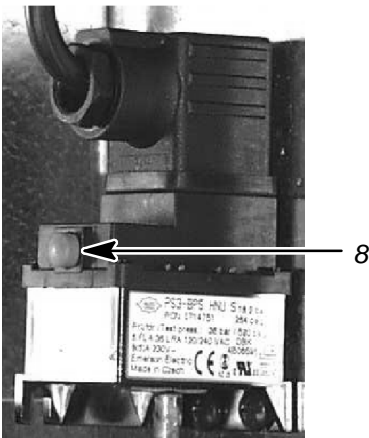

1 RESET

8.3 Stopping the Refrigerated Dryer

- ☞ Close the compressed air shut-off valves (inlet and outlet).

Attention!

The main switch (1) can be secured in the "0" position against inadvertent switch-on by a small padlock.

- ☞ Turn switch (1) to "0" (OFF).

The refrigerated dryer is switched off and the control lamp is off.

8.4 Trouble shooting



The local safety regulations (see chapter 2) and the regulations detailed in the "Safety" chapter must be complied with during trouble-shooting.

See chapter 7.3 and chapter 8.2. when starting the refrigerated dryer after the malfunction has been corrected.

8.4.1 Water in the compressed air system

Possible cause:

Moisture deposits in the compressed air pipe work that were formed before the dryer was started.

Bypass opened.

Compressed air inlet and outlet swapped.

The condensate is not drained out of the system.

Remedy:

Blow out the compressed air pipe work with dry air until no more moisture condenses.

Close the bypass.

Check the compressed air connections using the dimensional diagram.

Check the ECO-DRAIN (see chapter 9.2.4); Contact the authorized KAESER distributor.

8.4.2 High pressure losses via the refrigerated dryer

Possible cause:

Refrigerated dryer iced up on the air side.

Remedy:

Switch off the dryer until the air system has thawed. If the system ices up again after starting again, refer to authorized KAESER distributor.

8.4.3 Pressure dew point too high

Possible fault:

Ambient temperature too high.

Compressed air inlet temperature is too high.

Flow volume too high.

Low refrigerant.

Defective refrigerant compressor.

Defective condenser fan motor.

High contamination component in the compressed air causing scale in the compressed air system.

Condenser surface (refrigerant liquefier) contaminated.

Remedy:

Check the technical data, see chapter 1.2.

Check the technical data, see chapter 1.2.

Check the technical data, see chapter 1.2.

Refer to authorized KAESER distributor.

Refer to authorized KAESER distributor.

Refer to authorized KAESER distributor.

Clean the compressed air system.

See maintenance instructions chapter 9.2.2.

8.4.4 High compressed air losses

Possible fault:

Constant loss of pressure via the condensate drain.

Remedy:

Clean the ECO-DRAIN (see chapter 9.2.5).

8.4.5 Red LED on the ECO–DRAIN housing flashes

Possible cause:

Condensate not draining.

Remedy:

Check the ECO–DRAIN (see chapter 9.2.4); contact authorized KAESER distributor.

8.4.6 The safety pressure switch shuts down the refrigerated dryer

Possible fault:

Ambient temperature too high.

Condenser surface (refrigerant liquefier) contaminated.

Defective condenser fan motor.

Remedy:

Check the technical data, see chapter 1.2.

See maintenance instructions chapter 9.2.2.

Refer to authorized KAESER distributor.

9 Maintenance

9.1 Maintenance Instructions:



Before starting work, follow the procedure below to ensure the unit is not started or energized while maintenance work is being performed:

Work on the electrical equipment of the refrigerated dryer may only be carried out by a qualified electrician or trained personnel under the supervision of a qualified electrician according to local codes.

Lock the main disconnect in the "off" position in accordance with applicable lock out/tag out procedures (example: OSHA CFR 29 § 1910.147) to ensure the dryer does not restart.

Before starting work, carry out the following procedure to prevent inadvertent application of power to the refrigerated dryer:

- ☞ turn switch (1) to "0".
- ☞ lock out the switch (1) using a suitable padlock.

Before restarting the refrigerated dryer, ensure that:

- no maintenance personnel are working on the refrigerated dryer.
- all tools are removed from the refrigerated dryer.
- all guard and cover panels are properly installed and secured.

See chapter 7.3 and 8.2 for starting the refrigeration.

9.2 Regular Maintenance

Period	Work to be done	see chapter
Daily	Check the condensate outlet	9.2.3
50 hours after initial start	Clean the ECO-DRAIN	9.2.5
Every month	Check ECO-DRAIN for proper operation	9.2.4
	Clean the surface of the condenser	9.2.2
If necessary	Clean the ECO-DRAIN diaphragm valve	9.2.5
Every three month	General checks	9.2.1
Every year	Clean the ECO-DRAIN	9.2.5

The maintenance periods are recommended periods and may need to be adjusted based on installation and service conditions.

9.2.1 General checks

- ☞ Inspect the electrical components of the refrigerated dryer every two to three months. Correct any malfunctioning or worn components, such as loose connections or overheated cable immediately!



Escaping compressed air and/or refrigerant can cause injury to personnel and lead to damage to the dryer.

- ☞ Check all pipework, hoses and screwed fittings for leakage every two to three months and carry out a visual check for any external damage. Correct any faults immediately!



The refrigerant contained in the refrigerating system may not be vented to the open air. Always use a refrigerant recovery system when working on the refrigerant circulation. Dispose of unusable refrigerant according to environmental regulations!

9.2.2 Cleaning the condenser

Clean the condenser every month.

- ☞ Stop the refrigerated dryer by turning the switch (1) to the "off" position.
- ☞ Lock the switch (1) with a suitable padlock to prevent unauthorized switch-on.
- ☞ Clean the cooling fins of the refrigerant liquefier by blowing compressed air from the outside to the inside.

See chapter 8.2 to start the refrigerated dryer.

9.2.3 Check the condensate outlet daily as follows:

Attention!

If neither condensate nor compressed air exits, clean the ECO-DRAIN. (See chapter 9.2.5)

- ☞ Verify that condensate exits from the hose of the condensate drain outlet when the drain opens (the LED extinguishes for a short period).

9.2.4 Check ECO-DRAIN for proper operation monthly, as follows:

Check the function of the condensate drain by pressing the TEST pushbutton on the upper housing of the ECO-DRAIN. The solenoid valve of the ECO-DRAIN opens when the TEST pushbutton is pressed.

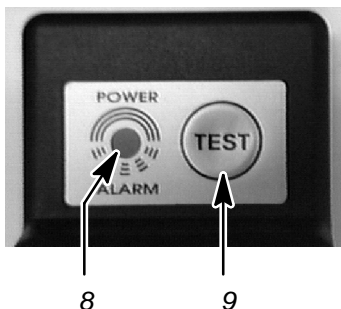

- 8 Operational status – light emitting diode
- 9 TEST pushbutton (condensate drain)

- ✎ Unscrew the two screws holding the left-hand side cover and remove the cover.
- ✎ Press the TEST pushbutton on the ECO-DRAIN housing.

Press the test pushbutton for at least 1 second. The valve will open every 2 to 3 seconds. The LED will flash to indicate the valve's opening and closing. Note that all accumulated condensate should drain.

Condensate does not drain:

- Outlet hose of the ECO-DRAIN is blocked.
If necessary, clean or replace the outlet drain hose.
 - Diaphragm valve is clogged.
See chapter 9.2.5.
 - Solenoid coil is defective.
Contact authorized KAESER distributor.
- ✎ Screw on the left-hand side panel.

9.2.5 Cleaning the ECO-DRAIN

Clean the condensate drain monthly, or more frequently depending on the degree of contamination of the compressed air.

It is recommended that the ECO-DRAIN is cleaned after the first 50 hours of service.

Maintenance work on the ECO-DRAIN is only possible with the ECO-DRAIN removed.

Initial work:

- ✎ Stop the refrigerated dryer by turning the switch (1) to the "off" position.
- ✎ Lock the switch (1) with a suitable padlock to prevent unauthorized switch-on.
- ✎ Unscrew the two screws holding the left-hand side cover and remove the cover.



Before removing up the ECO-DRAIN it must be shut off from the compressed air.

- ✎ Close the shut-off valve in the air line to the ECO-DRAIN.

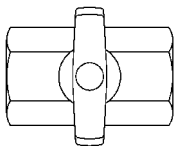

*Shut-off valve
closed*

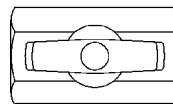

*Shut-off valve
opened*

Removing the ECO-DRAIN:

- ✎ Depressurize the ECO-DRAIN by pressing the TEST pushbutton.
- ✎ Unscrew the screw fittings between the shut-off valve and the ECO-DRAIN.
- ✎ Take out the ECO-DRAIN.

Attention!

The ECO-DRAIN is still connected to the power supply cable.

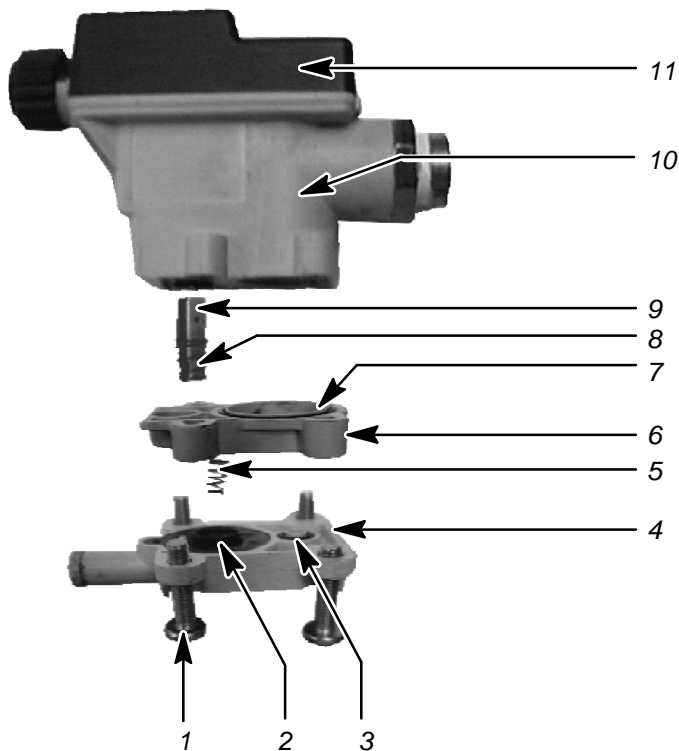

- | | |
|-------------------------------|----------------------------------|
| 1 Cross-head screws, M5 x 2.5 | 7 O Ring, 28 x 1.5 |
| 2 Diaphragm | 8 Thrust spring for valve piston |
| 3 O Ring, 6 x 1.5 | 9 Valve piston |
| 4 Diaphragm seat | 10 Housing |
| 5 Thrust spring for diaphragm | 11 Top cover |
| 6 Diaphragm cover | |

Items in () refer to items detailed in the previous figures.

Removal of the ECO-DRAIN:

Attention!

**Watch for loose parts fitted into each other that could easily be lost when disassembling the ECO-DRAIN.
Note the final positions of the individual parts.**

- ☞ Unscrew the four cross-head screws (1) on the diaphragm seat (4) and remove carefully with the diaphragm cover (6) from the housing (10). Watch for loose parts, such as the pressure springs (5) and (8), diaphragm (2) and the O rings (3) and (7)!

Cleaning:

- ☞ Remove the thrust spring (5), diaphragm (2) and valve piston (9) with its thrust spring (8) and clean them.



**Do not direct compressed air toward any person at any time.
Compressed air is contained energy and as such, is dangerous to life.**

Wear protective goggles when blowing out components.

- ☞ Blow out the diaphragm seat (4), diaphragm cover (6), and the housing inside with compressed air.

Reassembly of the ECO–DRAIN:**Attention!**

It is recommended that parts subject to wear, such as the diaphragm, valve piston and O rings be replaced annually for reasons of safety and reliability.

- ☞ Check the diaphragm (2), the existence and correct seating of the O rings (3) and (7) on the diaphragm seat (4) and diaphragm cover (6). Renew defective parts.
- ☞ Check the valve piston (9) for signs of wear and renew, if necessary.
- ☞ Check the existence and correct seating of the thrust spring (8) for the valve piston (9).
- ☞ Insert the valve piston (9) into the guide hole in the housing.
- ☞ Place the thrust spring (5) over the nipple on the diaphragm cover (6). Check that the thrust spring (5) sits correctly.
- ☞ Fit and position the diaphragm cover (6) over the valve piston (9) in the housing.
- ☞ Fit the diaphragm (2) into the opening in the diaphragm seat (4).
- ☞ Fit the diaphragm seat (4) to the diaphragm cover (6). Check that the thrust spring (5) is positioned in the recess provided in the diaphragm (2). Insert the four cross–head screws (1) through the holes provided in the vertically assembled diaphragm seat (4), diaphragm cover (6) and housing (10) and screw the components together tightly.

Final work:

- ☞ Fit the ECO–DRAIN with the screw fittings.
- ☞ Open the shut–off valve (in the compressed air line to the ECO–DRAIN).
- ☞ Carry out a functional check of the ECO–DRAIN (see chapter 9.2.4).
- ☞ Screw on the left–hand side panel.

See chapter 8.2 to start the refrigerated dryer.

10 Spare Parts and After Sales Service

Provide the following details for all queries and spare parts orders:
(see also the name plate)

Refrigerated dryer, model:

Serial number:

Part name:

Part order number:

Always provide the date of initial start up when making claims under warranty!

Name plate:

KAESER COMPRESSORS
Model
Part No.
Serial No.
Year of production
Refrigerant
Charge of refrigerant lb.
Max. work. press. (Refrig. sys.) psig
Tested leak-free
Max. work. press. (Air system) psig
Rated voltage
Rated current A
Ambient temperature °F / °F

11 Appendix

11.1 Wiring Diagram

Wiring Diagram
air dryer TD 51/61/76
460V 3Φ 60CY

manufacturer: KAESER COMPRESSORS
96450 COBURG
GERMANY

The drawings remain our exclusive property. They are entrusted only for the agreed purpose. Copies or any other reproductions, including storage, treatment and dissemination by use of electronic systems must not be made for any other than the agreed purpose. Neither originals nor reproductions must be forwarded or otherwise made accessible to third parties.

c		Datum	27.03.2003	USE		cover page	=
b		Bearb.	Zeeh			air dryer TD51/61/76	*
a		Gepr.	Zeeh				
A	Anderung	Datum	Name	Norm	Ersatz durch:	Ersatz für:	
						Ursprung: UTDU0911	
						DTD-U0915.00	
						Blatt 1	
						Bl.	

Lfd. Nr. No.	Benennung Name	Zeichnungsnummer (Kunde) Drawing No. (customer)	Zeichnungsnummer (Hersteller) Drawing No. (manufacturer)	Blatt Page	Anlagenkennzeichen Unit designation
1	cover page		DTD-U0915.00	1	=
2	list of contents		ZTD-U0915.00	1	
3	wiring diagram power unit/power supply		STD-U0915.00	1	
4	wiring diagram control unit		STD-U0915.00	2	
5	wiring diagram Volt-free contacts		STD-U0915.00	3	
6	component legend		STD-U0915.00	4	
7	electrical component parts list Control cabinet		GTD-U0915.00	1	
8	terminal connection terminal strip -X1		KTD-U0915.00	1	
9	lay-out control panel		ATD-U0915.00	1	

c	Datum		list of contents	=				
b	Bearb.							
a	Gepr.							
B	Änderung	Datum	Name	Ersatz durch:	Ersatz für:	Ursprung:	ZTD-U0915.00	*

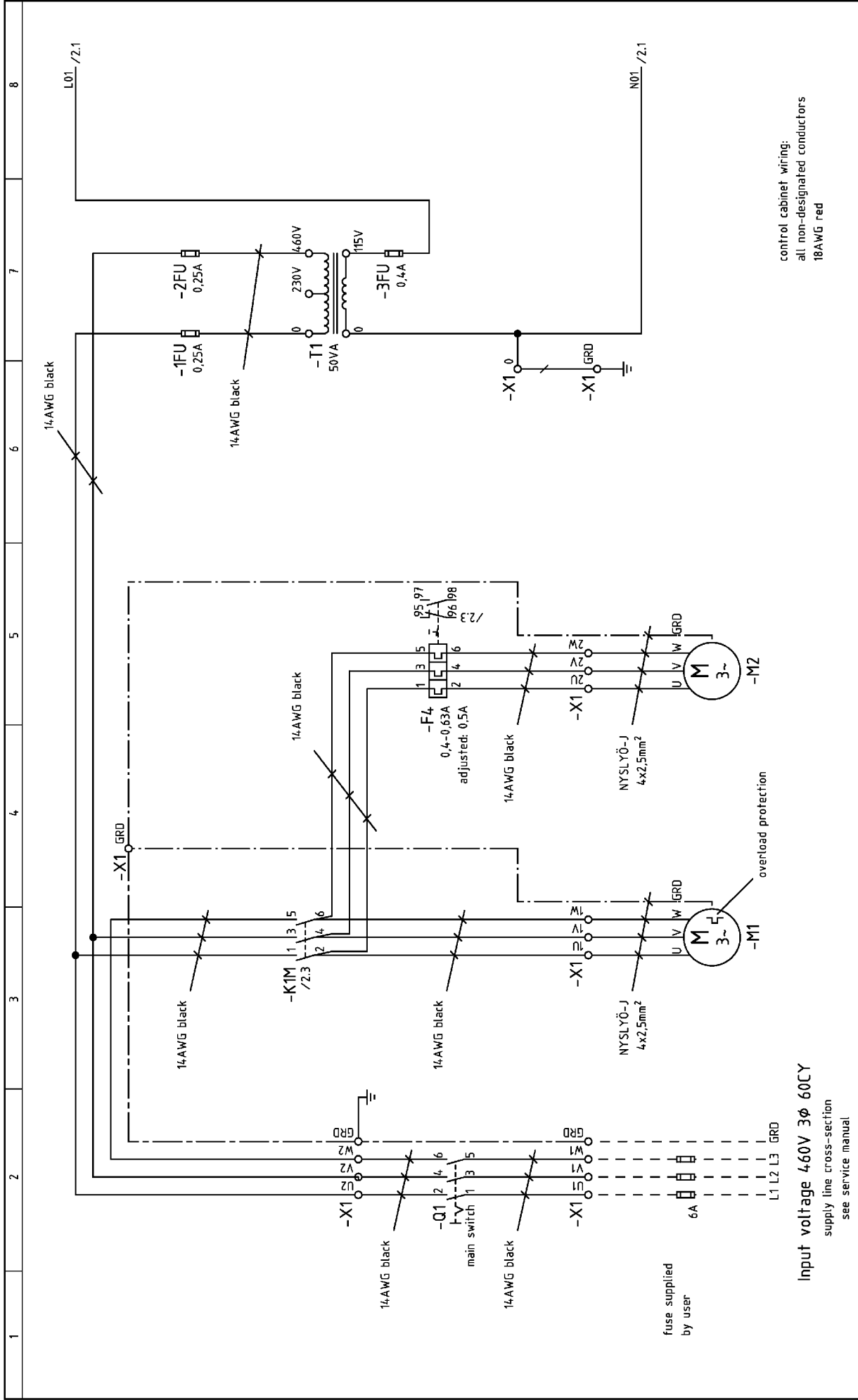

control cabinet wiring:
all non-designated conductors
18AWG red

Input voltage 460V 3φ 60CY
supply line cross-section
see service manual

Function:		compressor motor with overload protection		vent motor		115V/1-60CY	
Group of function:		power unit		control voltage tapping			
c	Datum	27.03.2003	wiring diagram				=
b	Bearb.	Zeeh	air dryer TD51/61/76				+
a	Gepr.	Zeeh	power unit/power supply				
D	Änderung	Datum	Name	Norm	Ersatz durch:		Blatt 1
					STD-U0915.00		Bl.

Lfd. Nr. No.	Benennung Name	Zeichnungsnummer (Kunde) Drawing No. (customer)	Zeichnungsnummer (Hersteller) Drawing No. (manufacturer)	Blatt Page	Anlagenkennzeichen Unit designation
1	cover page		DTD-U0915.00	1	=
2	list of contents		ZTD-U0915.00	1	
3	wiring diagram power unit/power supply		STD-U0915.00	1	
4	wiring diagram control unit		STD-U0915.00	2	
5	wiring diagram Volt-free contacts		STD-U0915.00	3	
6	component legend		STD-U0915.00	4	
7	electrical component parts list Control cabinet		GTD-U0915.00	1	
8	terminal connection terminal strip -X1		KTD-U0915.00	1	
9	lay-out control panel		ATD-U0915.00	1	

c	Datum	Benarb.	Datum	list of contents	=
b		Gepr.		KAESER KOMPRESSOREN	*
a		Norm			ZTD-U0915.00
B	Änderung Datum Name		Ersatz durch:		Blatt 1
			Ersatz für:		Bl.

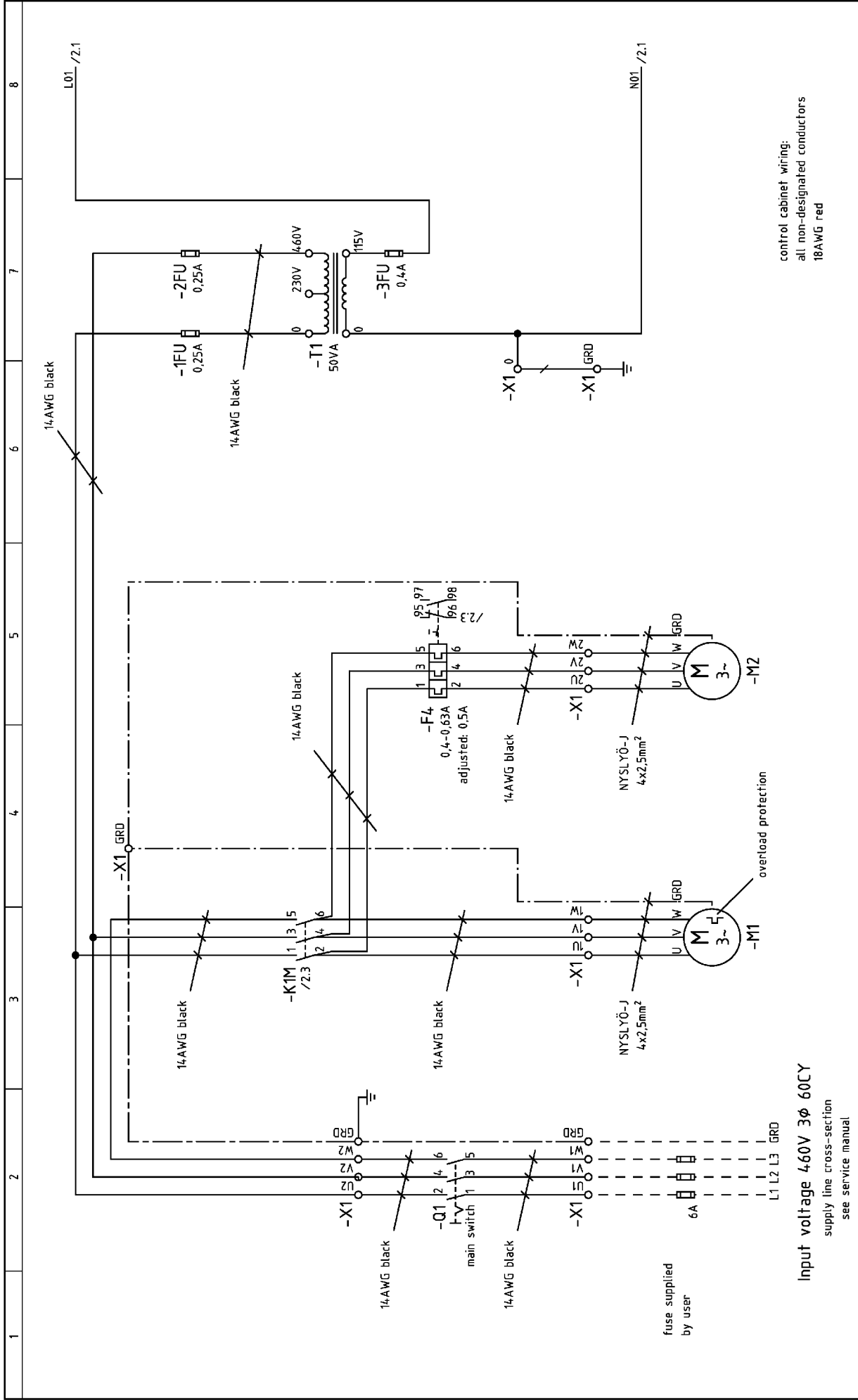

control cabinet wiring:
all non-designated conductors
18AWG red

Input voltage 460V 3φ 60CY
supply line cross-section
see service manual

Function:		compressor motor with overload protection		vent motor		115V/1-60CY	
Group of function:		power unit		control voltage tapping			
c	Datum	27.03.2003	wiring diagram				=
b	Bearb.	Zeeh	air dryer TD51/61/76				+
a	Gepr.	Zeeh	power unit/power supply				
D	Änderung	Datum	Name	Norm	Ersatz durch:		Blatt 1
					STD-U0915.00		Bl.

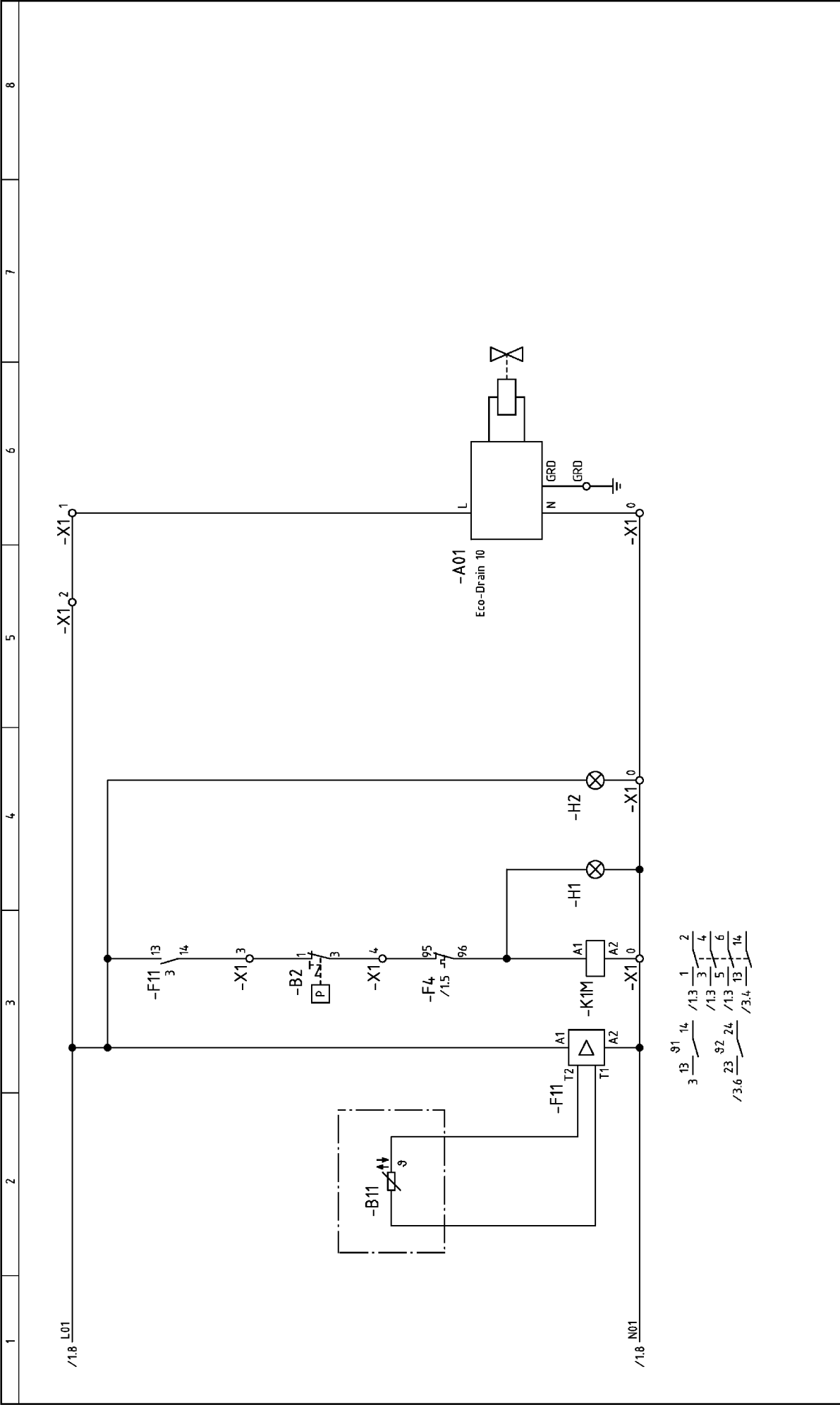

Function:		NTC-temperature control		control voltage ON		automatic condensate drain	
Group of functions:		NTC-temperature control		motor running		wiring diagram	
Date:		27.03.2003		air dryer TD51/61/76		=	
Drawn by:		Zeesh		control unit		*	
Checked by:		Zeesh		STD-U0915.00		Blatt 2	
Date:		Norm		Ersatz durch:		Bl.	
Date:		Norm		Ersatz für:		Bl.	

User's connection

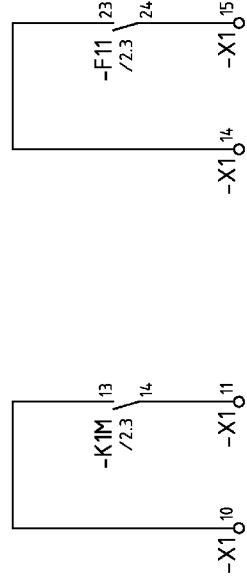

all non-designated conductors,
16AWG yellow

Function:		motor running		high dew point	
Group of functions:		Volt-free contacts		Volt-free contacts	
c	Datum	27.03.2003			
b	Bearb.	Zeesh			
a	Gepr.	Zeesh			
D) Änderung	Datum	Name	Ersatz durch:		Ersatz für:
			KAESER		KOMPRESSOREN
			wiring diagram		air dryer TD51/61/76
			=		*
			STD-U0915.00		Blatt 3
					Bl.

1	2	3	4	5	6	7	8
- A01 automatic condensate drain - B2 safety air pressure switch - B11 NTC-temperature probe - 1FU, -2FU primary control fuse - 3FU secondary control fuse - F4 overload relay, vent motor - F11 NTC-thermostat - H1, -H2 LED indicator - K1M motor starter - M1 compressor motor with overload protection - M2 vent motor - Q1 main switch - T0 auto-transformer - T1 control transformer - X1 terminal strip							

c	Datum	27.03.2003	component legend	=
b	Bearb.	Zeeh	air dryer TD51/61/76	*
a	Gepr.	Zeeh		
E	Änderung	Datum	Name	Norm
		Ersatz durch:		Ursprung: UTD0911
			KAESER KOMPRESSOREN	
			air dryer TD51/61/76	
			STD-U0915.00	
			Blatt 4	Bl.

1	2	3	4	5	6	7	8				
A Stückzahl Qty.	B Benennung und Verwendung Description and function	C Fabrikatbezeichnung Type, nomenclature, techn. data (e.g. Steuerspannung, Frequenz, Einstellbereich); Bestell-Nr.; Hersteller Identification data Type, basic technical data (e.g. control voltage, frequency, adjustable range); order No.; manufacturer	D Lfd. Nr. Item	E Betriebsmittel-Kennz. nach DIN 40719, Teil 2 Identifying symbol of device	F Stromlaufplan Planabschnitt Circuit diagram sheet No.; section No.	G Einbaort Location					
						H Schabl. Nr.	I BZ- Pos.	J VA Kz. →	K Eingangs- vermerk		
1	Control cabinet	7.4697.30010 CKC									
1	control panel	235x340x2,5 CKC									
1	motor starter - TD51/61/76 - 460V/60Hz	A9-30-10-89 115V	ABB	-K1M							
1	overload relay	TA25 DU0,63 0,4-0,63A	ABB	-F4							
1	adapter	DB25/25A	ABB	-F4							
1	control transformer	50VA 230-460/115V	Block	-T1/-3FU							
1	secondary control fuse	5x20 0,4A	89B336.0	-3FU							
1	fuse socket	USM 2 2-pole	7.3320.00020	-1FU,-2FU							
2	primary control fuse, 230V	ATQ 0,25 0,25A	7.3161.00150	-1FU,-2FU							
1	NTC-thermostat	TRN 122K-2-8 115V	7.4690.20040	-F11							
1	terminal strip	7.3165.10080	Wago	-X1							
	operating panel:										
1	Emergency Stop/main switch	KG20A 3-pole	890939.0	Solenoid					-Q1		
2	LED indicator	19511331 green	7.5720.0	EBT					-H1,-H2		

↳ Versandschritt - Kennzeichen

When reordering the equipment, all data enclosed by the heavy lines of columns B and C should be stated. In addition, the data in columns D to G should be given together, with the No. of this list of equipment, insofar as they are helpful in answering technical enquiries. When ordering spare parts, also quote the serial No. of the product if stated on the rating plate.

The German version applies in cases of doubt.

Bei Nachbestellung von Geräten und Maschinen sind alle in den stark umrandeten Spalten B und C angegebenen Daten aufzuführen. Die Daten in den Spalten D bis G sind zusätzlich unter Nennung dieser Geräte- und Maschinen-Nummer anzugeben, soweit sie die Beantwortung technischer Rückfragen erleichtern. Für Ersatzteilbestellung ist zusätzlich die Angabe der Seriennummer erforderlich, falls diese auf dem Typenschild des Erzeugnisses genannt ist.

In Zweifelsfällen gilt die deutsche Fassung.

c	Datum	27.03.2003	Erstellt durch:	electrical component parts list		Elektronik
b	Bearb.	Zeeh	Ersatz für:	air dryer TD51/61/76		Blatt 1
a	Gepr.	Zeeh	Ursprung:	Control cabinet		Bl. 1
F	Änderung	Datum	Name	GTD-U0915.00		

cable-no.	destination	terminal strip	location	name of device	connection	terminal strip: -X1 Total 26 terminals	[Grid]																									
							[Grid]																									
cable-no.	destination	terminal strip	location	name of device	connection	terminal strip: -X1 Total 26 terminals	[Grid]																									
							[Grid]																									
cable-no.	destination	terminal strip	location	name of device	connection	terminal strip: -X1 Total 26 terminals	[Grid]																									
							[Grid]																									

Volt-free contacts, User's connection
 1) motor running
 2) high dew point

c	Datum	27.03.2003		Ersatz durch:	Ersatz für:	Ursprung: UTD00911	KAESER KOMPRESSOREN	terminal connection air dryer TD51/61/76 terminal strip -X1	=	+	KTD-U0915.00	Blatt 1	Bl
		Bearb.	Zeeh										
b	Datum												
a	Datum												

s.b.c. = supplied by customer

s.b.c. 4x14AWG
 W2 NYSLY0 2x1 mm²
 W34 NYSLY0-J 3x1 mm²
 NYSLY0-J 4x2,5 mm²
 NYSLY0-J 4x2,5 mm²

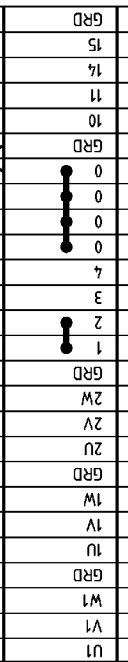

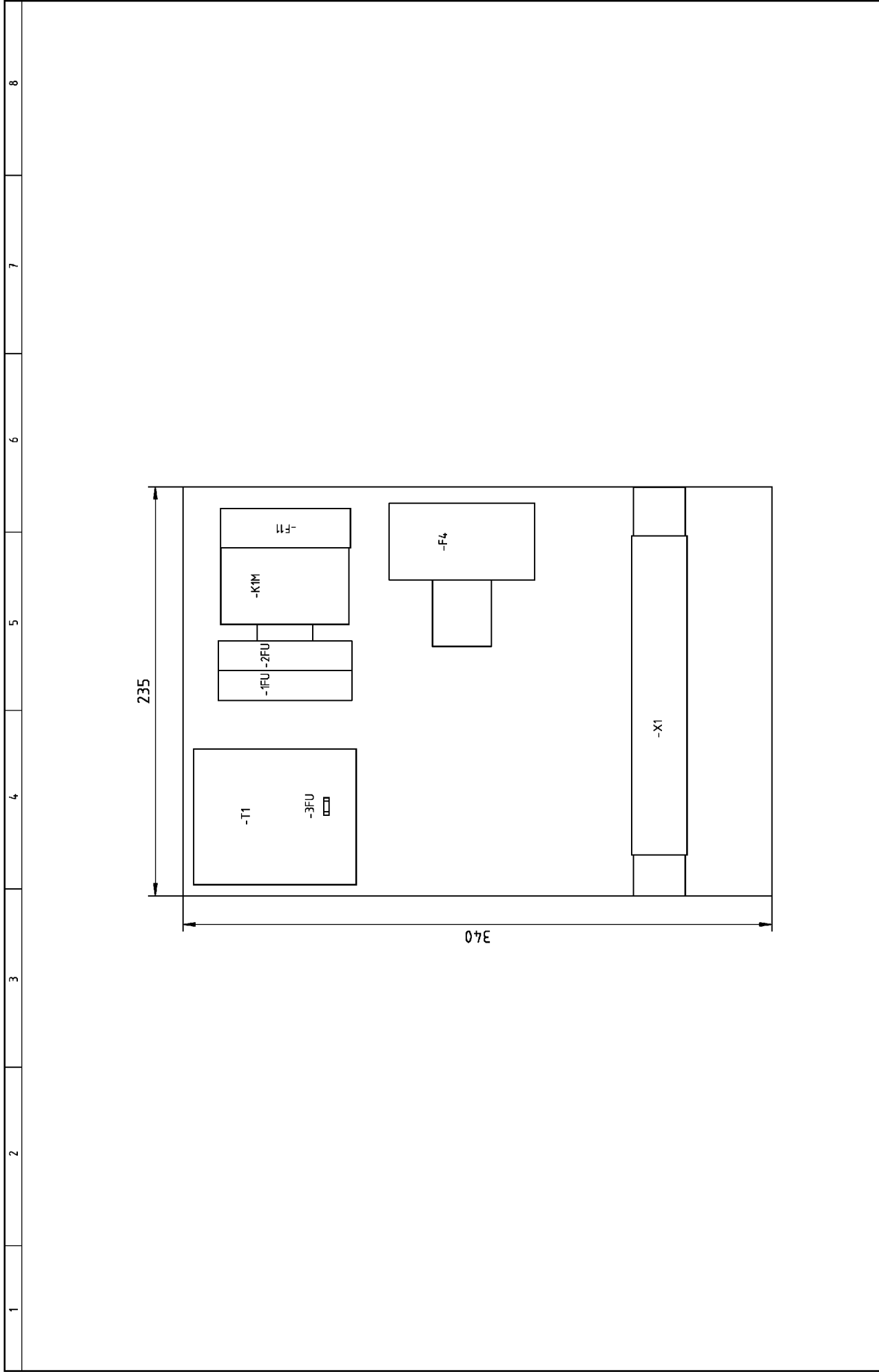

c	Datum	27.03.2003			lay-out		=
b	Bearb.	Zeeh			air dryer TD51/61/76		*
a	Gepr.	Zeeh			control panel		
II	Anderung	Datum	Name	Norm	Ersatz durch:	Ersatz für:	ATD-U0915.00
						Ursprung: UTDU0911	Blatt 1
							Bl.

11.2 Maintenance Schedule

Refrigerated dryer, model: Serial number:			
Date	Description of work	Operating hours	Signature