

# SERVICE MANUAL

USE

## Rotary Blower

**Model: OMEGA 61**

Part No.: 881005.01101 – V02

Serial No.: .....

# Table of Contents

<b>1</b>	<b>Technical Specification.....</b>	<b>1- 1</b>
1.1	Rotary Blower.....	1 - 1
1.2	Installation Requirements .....	1 - 1
1.3	Lubricating Oil Capacities .....	1 - 1
1.4	Recommended Lubricants.....	1 - 2
1.5	Designation .....	1 - 2
1.6	Dimensional Drawing .....	1 - 2
1.7	Performance curves.....	1 - 2
<b>2</b>	<b>Safety Regulations .....</b>	<b>2 - 3</b>
2.1	Explanation of Symbols and References .....	2 - 3
2.2	Accident Prevention Regulation .....	2 - 3
2.3	General References.....	2 - 4
2.4	Spare Parts .....	2 - 4
<b>3</b>	<b>General .....</b>	<b>3 - 5</b>
3.1	Correct Use.....	3 - 5
3.2	Copyright .....	3 - 5
<b>4</b>	<b>Transport .....</b>	<b>4 - 6</b>
4.1	Transport Instructions .....	4 - 6
4.2	Transport with a Fork Lift Truck or Lift Truck .....	4 - 6
4.3	Transport with a Crane Hook .....	4 - 6
4.4	Temporary Storage .....	4 - 7
<b>5</b>	<b>Construction and Principles of Operation .....</b>	<b>5 - 8</b>
5.1	Construction.....	5 - 8
5.2	Configuration.....	5 - 9
5.2.1	Vertical configuration .....	5 - 9
5.2.2	Horizontal configuration .....	5 - 10
<b>6</b>	<b>Installation .....</b>	<b>6 - 11</b>
6.1	Installation Requirements .....	6 - 11
6.2	Drive.....	6 - 11
6.2.1	Direct coupled drive with flexible coupling .....	6 - 12
6.2.2	V-belt drive .....	6 - 12
6.3	Compulsory Safety Equipment.....	6 - 12
6.3.1	Safety valve.....	6 - 12
6.3.2	Check valve.....	6 - 12

# Table of Contents

6.3.3	Display of temperature and pressure.....	6 - 12
6.3.4	Monitoring devices for operational parameters.....	6 - 13
6.3.5	Noise reduction measures .....	6 - 13
6.3.6	Measures for the protection of personnel from sources of danger .....	6 - 13
<b>7</b>	<b>Putting into Operation.....</b>	<b>7 - 14</b>
7.1	Points to be Observed before Putting into Operation .....	7 - 14
7.2	Points to be Observed before Starting the Rotary Blower .....	7 - 14
<b>8</b>	<b>Operation .....</b>	<b>8 - 15</b>
8.1	Starting and Stopping the Rotary Blower .....	8 - 15
8.2	Action to be taken during a Malfunction .....	8 - 15
8.2.1	Abnormal running noises .....	8 - 15
8.2.2	Excessive blower temperature.....	8 - 15
8.2.3	Oil leaking into air chamber .....	8 - 15
8.2.4	Low inlet volume flow .....	8 - 16
<b>9</b>	<b>Maintenance.....</b>	<b>9 - 17</b>
9.1	Observe the following rules during all maintenance and service work .....	9 - 17
9.2	Regular Maintenance .....	9 - 17
9.3	Lubricating Oil Level Check / Topping up the Lubricating Oil .....	9 - 17
9.4	Lubricating Oil Change.....	9 - 18
9.5	Cleaning the Rotary Blower.....	9 - 19
<b>10</b>	<b>Spare Parts and After Sales Service.....</b>	<b>10 - 20</b>
<b>11</b>	<b>Appendix .....</b>	<b>11 - 21</b>
11.1	Maintenance Schedule.....	11 - 21
11.2	Safety information concerning contamination of compressors, blowers, vacuum pumps and components .....	11 - 22

## 1 Technical Specification

### 1.1 Rotary Blower

Model .....	OMEGA 61
Part No.....	881005.01101
Configuration .....	vertical or horizontal *
Direction of rotation .....	cw or ccw*
Flow at maximum speed and maximum pressure .....	1056 CFM
The effective volume flow is dependent on the speed and the relative pressure.	
Power consumption** .....	84.3 BHP
(at maximum speed and maximum differential pressure)	
Maximum radial loading of the shaft (e.g. belt tension) .....	1416 lbf
Maximum operating speed of the rotors .....	3600 rpm
Maximum operating gauge pressure.....	12 psig
Maximum pressure difference $\Delta p$ in pressure operation discharge pressure – inlet pressure .....	12 psid
Maximum pressure difference $\Delta p$ in vacuum operation discharge pressure – inlet pressure .....	15 inch Hg
Maximum pressure ratio discharge pressure to inlet pressure .....	2:1
Maximum discharge temperature.....	320 °F
Maximum temperature rise inlet temperature –discharge temperature .....	207 °F
Flange connection: inlet port/discharge port ....	Flange adapter 6"
Weight .....	550 lbs

\* The configuration and direction of rotation can be selected by the user according to installation requirements. Configuration: Horizontal.  
It is necessary to modify the block for vertical direction of flow (see chapter 6.1).

\*\* The power consumption is dependent on the operating point required,  
e.g. volume flow, differential pressure.

### 1.2 Installation Requirements

Minimum ambient temperature* .....	5 °F
Maximum ambient temperature* .....	140 °F

\* These temperature limits determine the lubricant required according to application  
(see lubricant recommendations for further details).

### 1.3 Lubricating Oil Capacities

Configuration	Drive end	Gear end
vertical	22 ± 15 % oz	29 ± 15 % oz
horizontal	34 ± 15 % oz	44 ± 15 % oz

## 1.4 Recommended Lubricant

Use the following lubricant depending on ambient temperature and the expected oil temperature.

Temperature	Recommended lubricant	ISO Viscosity Grade
Ambient temperature: 25°F to 140°F Oil temperature: up to 250°F	OMEGA SB-220*	220
Ambient temperature: 5°F to 105°F Oil temperature: 25°F to 140°F	SHELL Morlina 100 (Mineral Lubricant)	100
Ambient temperature: 25°F to 140°F Oil temperature: 35°F to 230°F	SHELL Morlina 220 (Mineral Lubricant)	220

\* Synthetic lubricant specially formulated for rotary lobe blowers.

**Attention!**

**The rotary blower is filled at the factory for horizontal configuration. The vertical configuration requires more lubricant (see chapter 1.3)**

**Type of lubricant used: SHELL Morlina 220.**

Consult factory for other viscosity grades for special applications.

## 1.5 Designation

The name plate of the rotary blower is located on the bearing case (gear end).

		Fredericksburg, VA 22404 Tel. (540) 898 - 5500	
OMEGA <small>Model</small>		S/N	
P/N		Year	
For maximum operating limits see service manual			

886018.0

## 1.6 Dimensional Drawing

See following page: Drawing-No. 881005.01101

## 1.7 Performance curves

Pressure curve see following page: Info Version 2.0

Vacuum curve see following page: Info Version 2.0

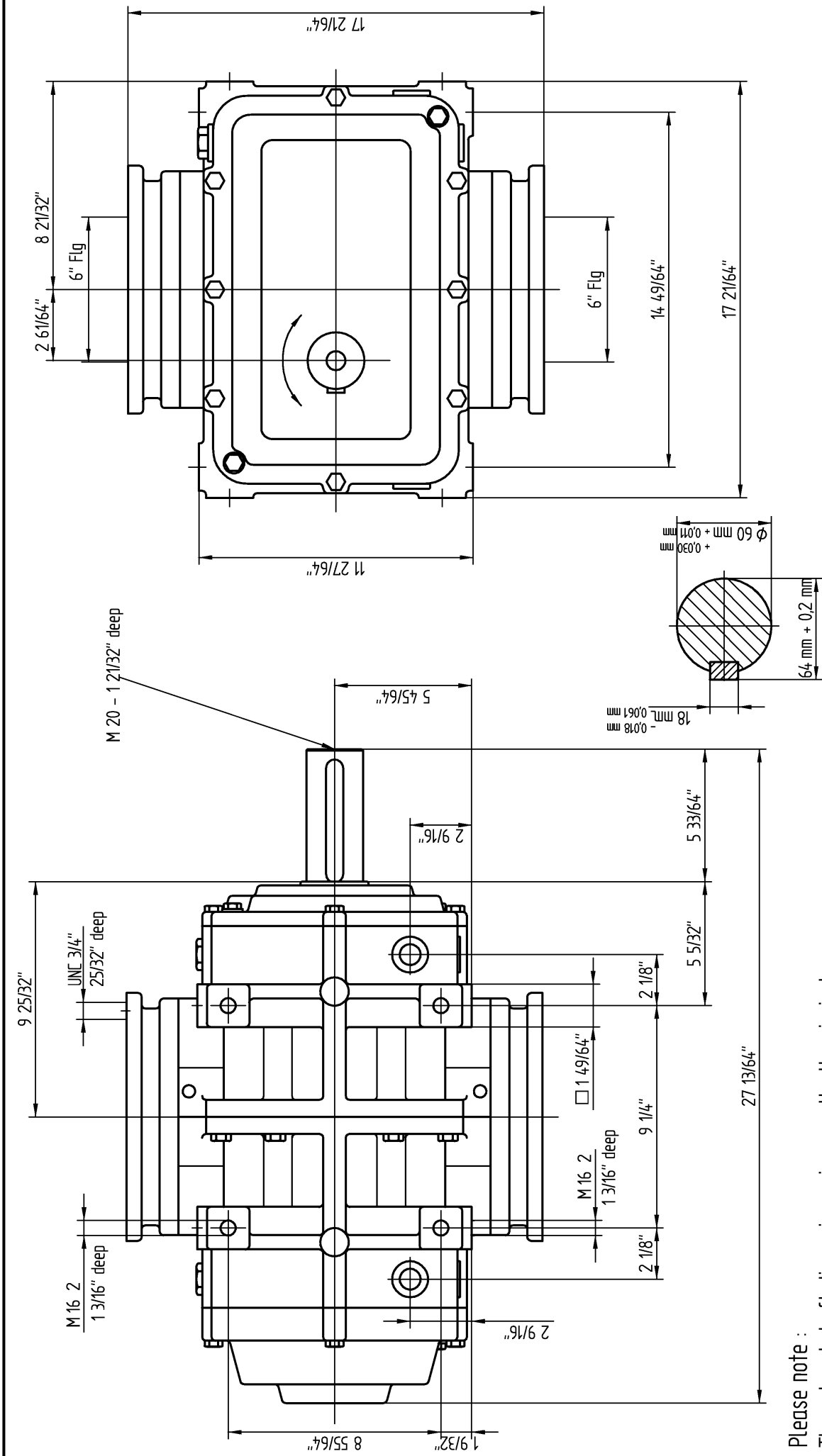

Please note :  
 Thread and shaft dimensions in mm; all other in inches  
 Blower must be mounted on a completely flat surface  
 Permissible flatness : 0,002"



OMEGA 61 881005.01101

Stand:	Datum:	Name:	CAD-Datei:
04.10.99	04.10.99	Meyer	MB000564.dft

PRESSURE PERFORMANCE  
14,7 PSIA and 68° F

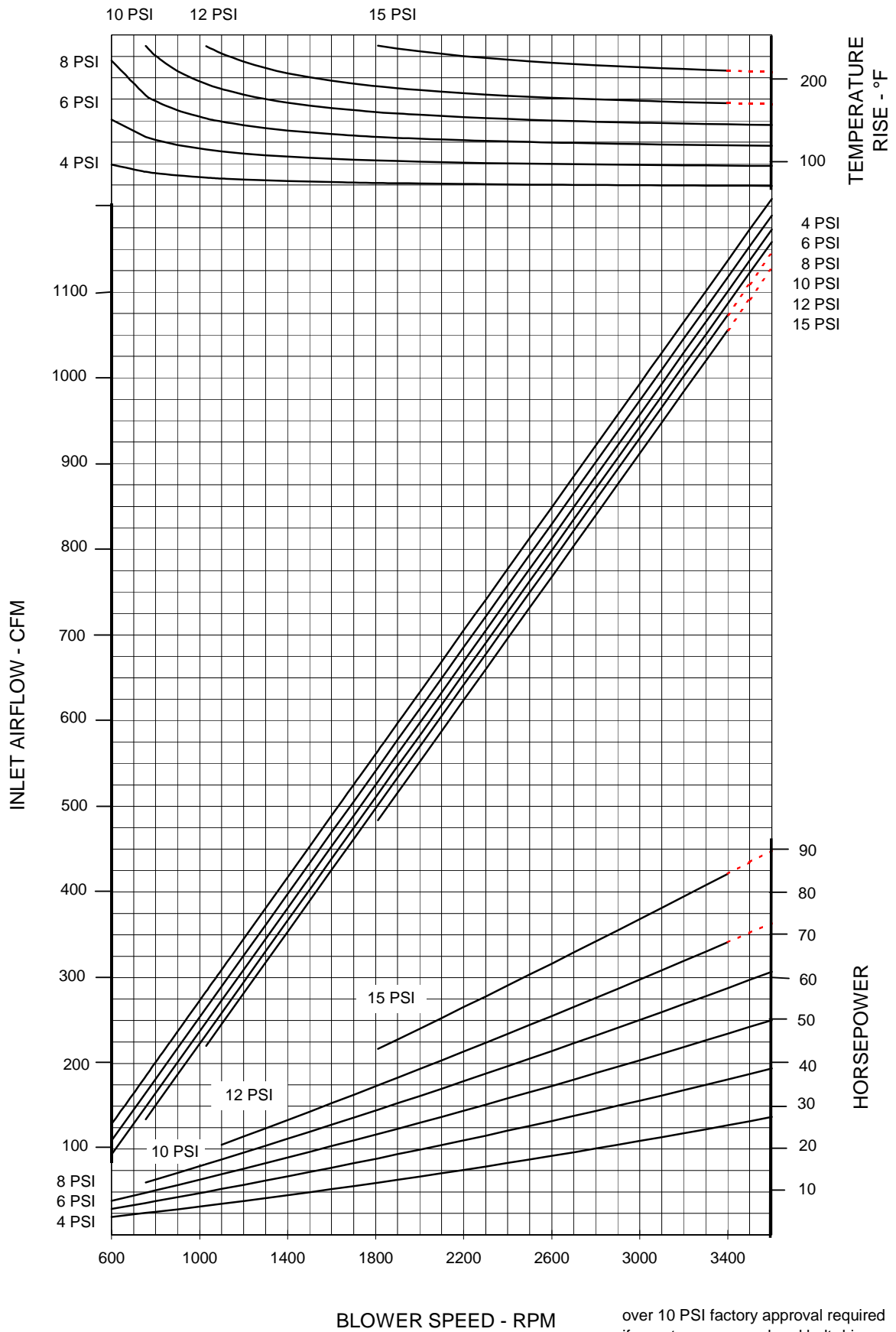

over 10 PSI factory approval required  
if near to max. speed and belt drive

VACUUM PERFORMANCE  
14,7 PSIA and 68° F

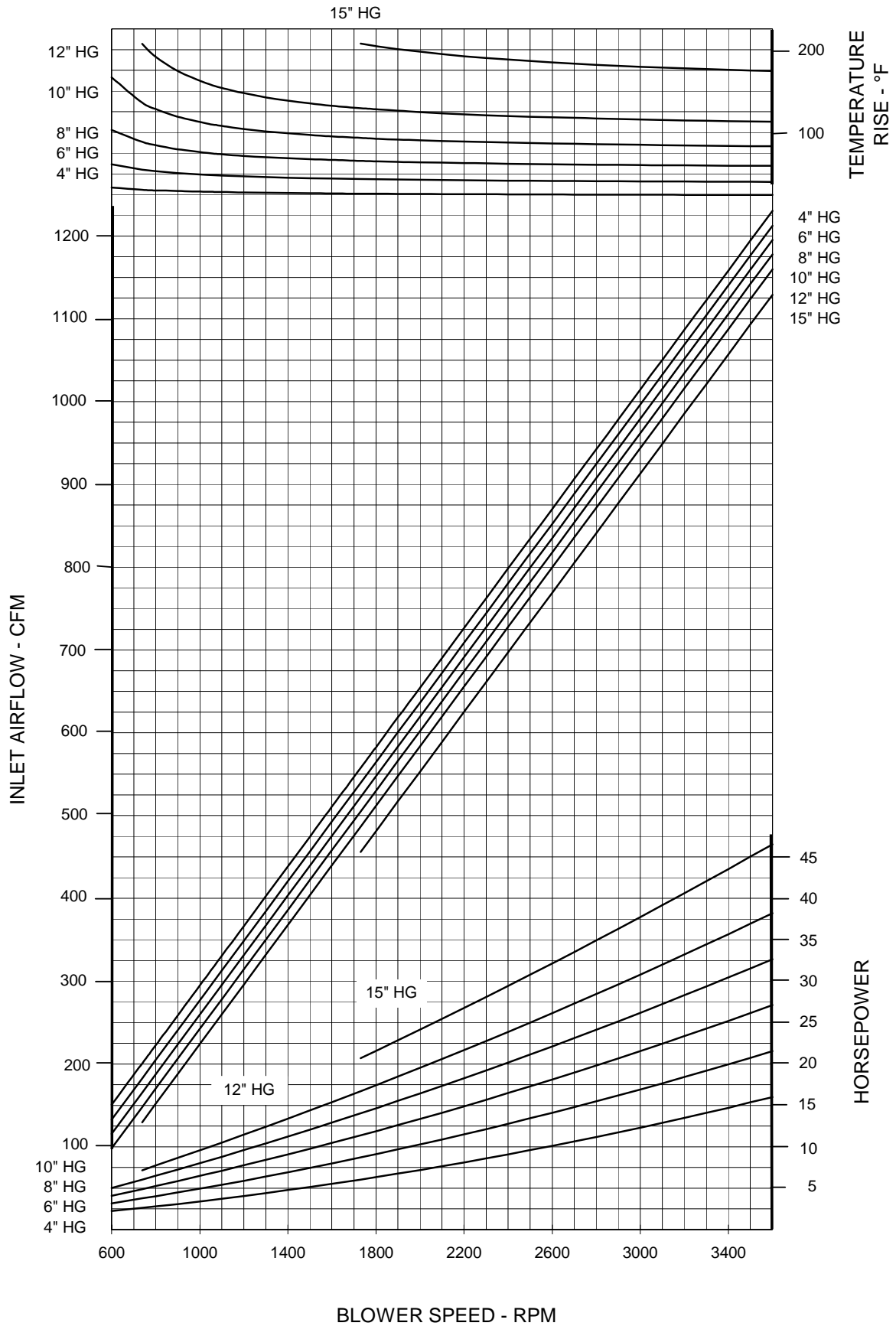



## 2 Safety Regulations

Read this service manual carefully and observe all cautionary references before putting the rotary blower into operation and before carrying out any maintenance.

### 2.1 Explanation of Symbols and References



This symbol is placed before all references to safety where danger to life and limb can occur during work. It is especially important that these rules are observed and that extreme care is taken in these cases. For their own protection, inform all other users of these safety rules. Observe general safety and accident prevention regulations as well as the safety rules laid down in this service manual.

Attention!

This symbol is placed at points where considerable attention must be paid to recommendations, regulations, references and correct sequence so that damage and/or destruction of the rotary blower and/or other equipment is prevented.



This symbol identifies environmental protection measures.



This symbol indicates operations to be carried out by the operator or service technician.



This bullet identifies listings.

Explanation of the warning notice on the rotary blower:



**Warning:**  
Hot surface, do not touch.

### 2.2 Accident Prevention Regulations



No open flame and flying sparks at the place of installation.

During any welding work necessary on the rotary blower or nearby ensure that sparks or high temperatures cannot cause fire or explosion.

Operating personnel must be instructed on the necessity of wearing ear muffs during operation of the rotary blower, especially during operation without the acoustic hood.

Do not linger for long periods in the direct vicinity of rotary blowers with damaging noise levels.

Do not use rotary blowers for explosive or damaging gases.

Because of the high temperatures generated (up to 300 °F), do not touch pipes or ancillaries during operation of the rotary blower. Wait until the blower has cooled down and pressure is vented before carrying out repairs to pipework.

Use only the lubricants recommended by the manufacturer.

## 2.3 General References

**Attention!**

The rotary blower is not capable of independent function and is designed as a built – in unit or as a unit complementary to another machine.

The rotary blower may only be put into operation as an integral part of the complete machine and then only after the complete machine was subjected to a safety inspection proving that it conforms to the requirements of the accident prevention regulations (see OSHA CFR 29 § 1910), e.g. protective guards at sources of danger such as noise, high temperature, etc.



Work on power driven systems may be carried out by trained or specialised personnel only.

**Attention!**

The warranty is invalidated if modifications are carried out without previous consultation with and the consent of KAESER COMPRESSORS, INC.

## 2.4 Spare Parts

Safe and reliable rotary blower operation is guaranteed only with original KAESER spare parts.

## 3 General

### 3.1 Correct Use

**Attention!**

The rotary blower package is intended solely for the transport of oil-free air or any inert gas without any liquids or solids and in conformity with the technical specification (see chapter 1.1).

For special gas applications contact KAESER COMPRESSORS, INC.



Do not use this blower for any combustible gas applications.

Any other use is considered incorrect. The manufacturer cannot accept liability for any damage caused by incorrect use. The user alone is liable for any risks incurred. Correct use also means compliance with the installation, removal, commissioning, operational and maintenance instructions laid down by the manufacturer.

This service manual is intended for operating, maintenance and supervisory personnel use only.

### 3.2 Copyright

©1994 KAESER COMPRESSORS, INC.

All rights reserved. No part of this manual may be reproduced in any form by any means without permission of KAESER COMPRESSORS, INC.

## Transport

### 4 Transport

#### 4.1 Transport Instructions

To avoid damage to the rotary blower we recommend the use of a fork lift truck, lift truck or a sling for transporting the rotary blower.

See chapter 1.1 for the weight.

#### 4.2 Transport with a Fork Lift Truck or Lift Truck

Always place the rotary blower on a suitable transporting medium (e.g. pallet) when transporting with a fork lift truck or lift truck.

**Attention!**

Never drive directly underneath and lift the rotary blower with the bare forks.

#### 4.3 Transport with a Crane Hook

**Attention!**

When transporting the rotary blower with a crane all standard regulations regarding this type of operation must be complied with.



Do not stand below a hanging load.

Do not exceed the maximum permissible lifting weight specified for the lifting appliance.

When lifting the rotary blower with a crane hook and slings use the two eyebolts provided. Screw these eyebolts into the threaded holes in the upper mounting faces at a slant from corner to corner.

**Attention!**

Take care that the eyebolts are screwed fully into the block. Avoid sudden, sharp vertical movements when lifting, lowering and transporting the rotary blower.

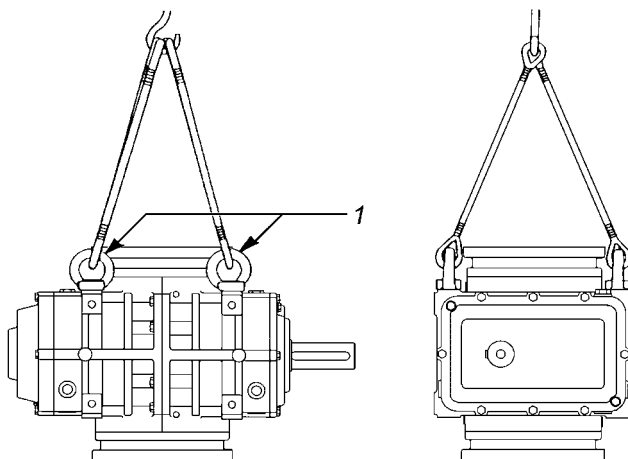

1 Eyebolts

## 4.4 Temporary Storage

**Attention!**

Store the rotary blower in a dry, enclosed space. Leave the flanged ports blanked off to prevent contamination.

### Temporary storage for longer than one year:

- ☞ Spray preserving oil onto the flanged ports, drive shaft, air chamber and any other base metal to protect against corrosion. Blank off the flanged ports again.
- ☞ Carry out an oil change annually ( see chapter 9.4).

### Recommended preserving oil:

External:

EXXON RUST BAN 326  
MOBIL Mobilarma 777 or 778  
SHELL V-Product 9703

Internal:

MOBIL Mobilarma 523 or 524  
SHELL RIMULA 30 or ROTELLA T 20W20

or similar makes.

### Putting into operation after a long period of temporary storage:

- ☞ Remove the preserving material from the air chamber with a suitable solvent.
- ☞ Carry out the measures detailed for installation and putting into operation.
- ☞ Carry out an oil change (see chapter 9.4).

## 5 Construction and Principle of Operation

### 5.1 Construction

Two rotors, synchronised by a pair of timing gears, rotate in opposite directions in two cylindrical bores within a housing. A defined quantity of air entering the inlet port is trapped between the rotors and the housing and carried round to the discharge port.

Because there is no contact between the rotors rotate and the housing there is no wear and no lubrication is required.

The integrated feet on all sides of the housing allow a universal installation; standing, lying mounted at the sides, mounted on or under.

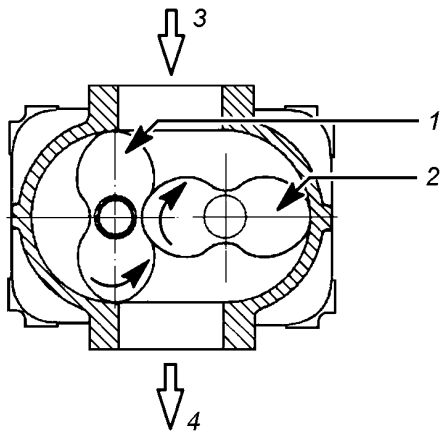

- |                |                  |
|----------------|------------------|
| 1 Male rotor   | 3 Inlet port     |
| 2 Female rotor | 4 Discharge port |

## Construction and Operation

### 5.2 Configuration

KAESER rotary blower are delivered in the „horizontal flow configuration“.

See chapter 6.1 for other configurations.

#### 5.2.1 Vertical flow configuration

- The drive shaft (11) is located at the upper rotor.

**Attention!**

**In the vertical flow configuration the rotary blower may only be operated with the drive shaft located at the upper rotor.**

**If it is required to locate the drive shaft at the lower rotor in vertical configuration, KAESER COMPRESSORS, INC. must be consulted first.**

- See the following diagramm for the positions of the oil level sight glasses (7) / (9) and oil filler plugs (1) / (3).
- The gas vents (5) are open.
- The gas vents (8) for vertical flow configuration are closed.
- See chapter 1.3 for oil capacities.

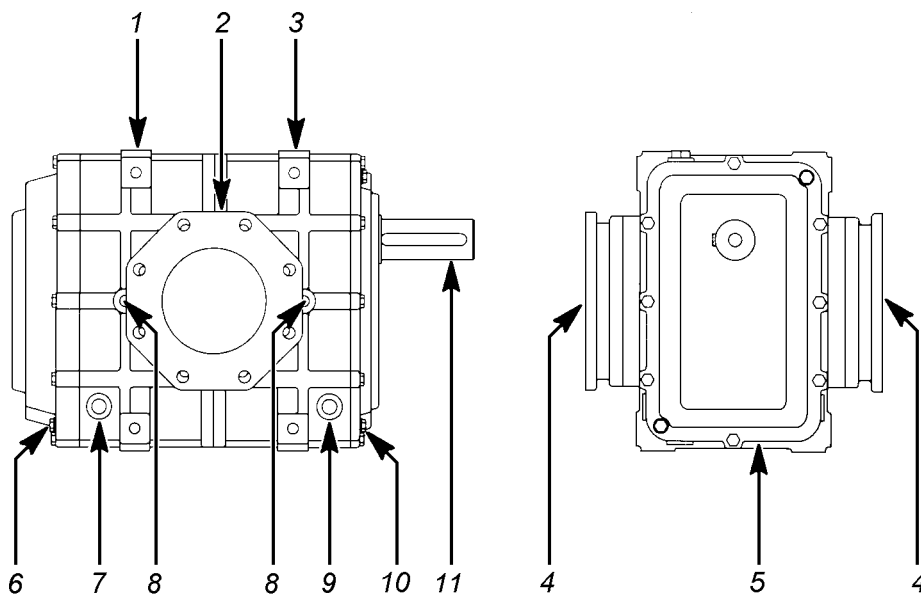

- |                              |                                                          |
|------------------------------|----------------------------------------------------------|
| 1 Oil filler, gear end       | 7 Oil level sight glass, gear end                        |
| 2 Test gauge plug            | 8 Gas vent opening for horizontal configuration (closed) |
| 3 Oil filler plug, drive end | 9 Oil level sight glass, drive end                       |
| 4 NPT Adapter                | 10 Oil drain, drive end                                  |
| 5 Gas vent opening (open)    | 11 Drive shaft                                           |
| 6 Oil drain, gear end        |                                                          |

## Construction and Operation

### 5.2.2 Horizontal flow configuration

- The drive shaft (11) is located at the left-hand rotor.

**Attention!**

In the horizontal flow configuration the rotary blower may only be operated with the drive shaft located at the left-hand rotor.

If it is required to locate the drive shaft at the right-hand rotor in horizontal configuration, KAESER COMPRESSORS must be consulted first.

- See the following diagram for the positions of the oil level sight glasses (9) / (10) and oil filler plugs (3) / (5).
- The gas vents (6) are open.
- The gas vents (2) for horizontal flow configuration are closed.
- See chapter 1.3 for oil capacities.

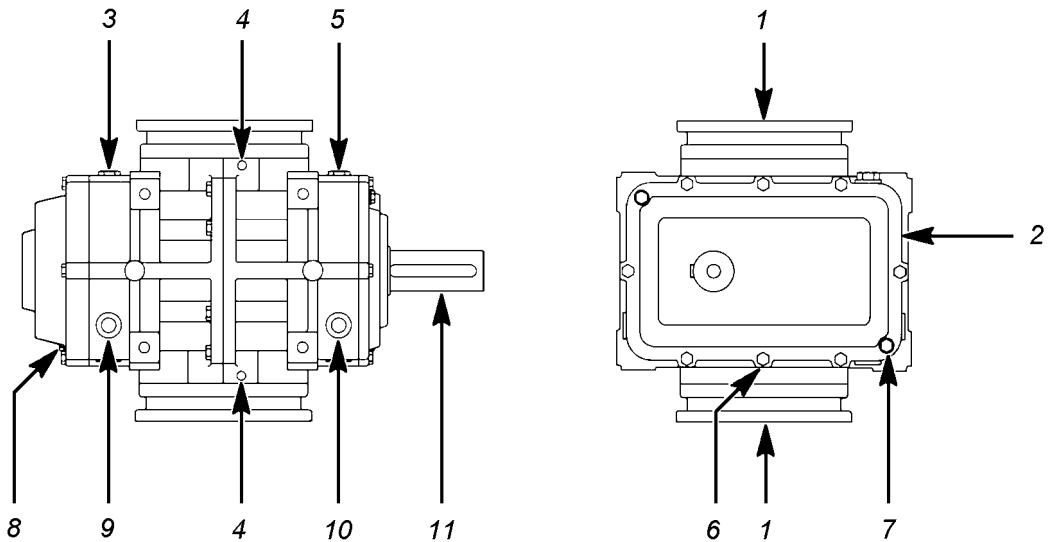

- |                                                        |                                     |
|--------------------------------------------------------|-------------------------------------|
| 1 NPT Adapter                                          | 6 Gas vent opening (open)           |
| 2 Gas vent opening for vertical configuration (closed) | 7 Oil drain, drive end              |
| 3 Oil filler plug, gear end                            | 8 Oil drain, gear end               |
| 4 Test gauge plug                                      | 9 Oil level sight glass, gear end   |
| 5 Oil filler plug, drive end                           | 10 Oil level sight glass, drive end |
|                                                        | 11 Drive shaft                      |



# Installation

## 6 Installation

### 6.1 Installation Requirements

- Always operate rotary blowers in a dry and dust-free environment.
- Tapped holes are provided on the housing feet for mounting purposes (see chapter 1.6 for details of size).

**Attention!**

**Mount the rotary blower on a stable and level base (flatness tolerance 0.002"). Take care not to stress the housing.**

☞ Check the drive shaft for ease of rotation by hand after installation.

- Leave the flanged ports blanked off until the pipework is finally connected to prevent foreign particles and/or contamination from entering blower.
  - Arrange for suitable support of the pipework, inlet and discharge silencers and any other connected components.
  - Only flexible pipe connections are permitted when connecting up the rotary blower to the pipework.
- ☞ Remove the blanks from the flanged ports before connecting up the pipework and inspect the air chamber of the rotary blower for the presence of dirt and foreign bodies. Clean, if necessary.

#### Vertical or horizontal configuration:

☞ During installation of the rotary blower check that the oil level sight glass and the oil filler plugs are correctly situated according to the intended configuration (Oil filler plugs at the gear end and the drive end), if necessary, change them (see chapter 5.2).

**Attention!**

**Gas vent openings are located on the rotary blower for both horizontal or vertical configurations. They are plugged for shipping purposes: 2 metal plugs on the ride side and 2 plastic plugs at the bottom. Remove plastic plugs prior to installation of blower. Take care during installation that the open gas vent openings are always located at bottom of blower housing, regardless of which configuration is used (see chapter 5.2).**

☞ Close the gas vent openings intended for other configurations.

### 6.2 Drive

- The rotary blower can be driven by all standard drive sources available on the market.
- The rated power of the drive source should be greater than power requirements of blower. Motor should have 1.15 service factor.
- The speed of the drive source must be selected or controlled such that the maximum permissible rotor speed (see chapter 1.1) cannot be exceeded.
- Axial loading of the drive shaft must be avoided at all costs because the shaft bearings are not constructed to accept large axial forces.
- For maximum radial shaft and loading see chapter 1.1.
- Always use the centering thread on the end of the shaft when fitting pulleys and couplings.

## Installation

---

**Attention!** Protect pulleys and couplings against impact effect. Do not hammer on the shaft.

### 6.2.1 Direct coupled drive with flexible coupling

- The shaft ends of the rotary blower and the drive source must be precisely aligned.
- Set up the drive source to the shaft end of the rotary blower.
- The tolerances for the run of the coupling as detailed in the manufacturer's technical specification must be complied with.

### 6.2.2 V-belt drive

- See chapter 1.1 for details of the maximum radial loading of the shaft end (V-belt tension) at the rotary blower.
- Misalignment of the V-belt drive may not exceed  $\pm 0.5^\circ$ . This applies to both the parallelism of the shaft axis spacing and the diagonal run of the V-belts resulting from axial offset.
- The pulleys for the rotary blower must be balanced.
- Check the tension of the V-belts and adjust if necessary when first putting into operation. After every V-belt change check the tension after 30 minutes and after 24 hours of further service.  
The regular maintenance period should be 500 service hours.

## 6.3 Compulsory Safety Equipment

**Attention!** To ensure safe, automatic operation of the rotary blower the user must install safety and control equipment.

### 6.3.1 Safety valve

Blow-off or vacuum limiting valve is necessary to prevent the nominal operating pressure from being exceeded or undercut.

#### Set point

The set point on the safety valve must correspond to the designed pressure difference.

**Attention!** It must be ensured through the type of construction and the cross-section of the safety valve that the pressure difference cannot increase under any operational conditions whatsoever by more than 1 psi (this also applies at full blow-off capacity of the safety valve).

The required safety valve blow-off volume is determined by the flow capacity defined for the rotary blower application.

The limiting values defined in chapter 1.1 must be complied with.

### 6.3.2 Check valve

A check valve is necessary to prevent a reversal of the specified direction of flow.

**Attention!** The sizing of the check valve is determined by the size of the discharge port flange (see chapter 1.1) and the difference pressure approved for the application concerned.

### 6.3.3 Display of temperature, pressure and vacuum

According to the application concerned, it is necessary to provide local display of the temperature, pressure or vacuum in the inlet and discharge ports.

### 6.3.4 Monitoring devices for operational parameters

To increase operational safety the parameters for

- discharge pressure
- pressure difference
- discharge temperature

must be monitored and interlocked to the drive.

### 6.3.5 Noise reduction measures

The use of inlet and discharge silencers and/or sound enclosures is decided by the application conditions for the rotary blower.



**Personal protective measures (e.g. earmuffs) for the maintenance and operating personnel must be met according to the accident prevention regulations (see OSHA CFR 29 §1910).**

### 6.3.6 Measures for the protection of personnel from sources of danger



**Because of danger to maintenance and operating personnel, e.g. from rotating parts (belt drive), high temperatures and noise, protective measures preventing such dangers must be taken by the user (see OSHA CFR 29 §1910).**

## Putting into Operation

---

### 7 Putting into Operation

#### 7.1 Points to be Observed before Putting into Operation

Every rotary blower is given a test run in the factory and carefully checked before shipment. The test run confirms that the rotary blower conforms to the specification data and runs perfectly. However, it is recommended that the rotary blower is inspected for damage that could have occurred during transport.

**Attention!**

The user carries full responsibility for the installation of the rotary blower and the compulsory safety equipment required.

#### 7.2 Points to be Observed before Starting the Rotary Blower:



**NON-OBSERVANCE OF THIS OR OTHER REFERENCES (WARNING; ATTENTION) CAN LEAD TO ACCIDENTS CAUSING INJURY TO PERSONNEL OR DAMAGE TO EQUIPMENT.**

- It is expected that the user employs safe working techniques and that all lawful operating and safety regulations are followed when operating this rotary blower.
- The user of this rotary blower is responsible for its safe operating condition.
- Do not operate this rotary blower in spaces where heavy dust conditions, poisonous or inflammable gases could exist.
- The installation and operating regulations for ancillary equipment must be complied with.
- Carry out a check of all compulsory safety and monitoring equipment.
- Check the oil level and top up if necessary (see chapter 9.3).
- Check the direction of rotation of the rotary blower.

## 8 Operation

### 8.1 Starting and Stopping the Rotary Blower

The rotary blower is started by switching on the drive source in accordance with the safety regulations (see chapter 2) and the regulations for putting the drive source into operation.

Starting and stopping of the rotary blower is also subject to the application parameters specified by the use.

### 8.2 Action to be taken during a Malfunction



The general safety regulations (see chapter 2) and the corresponding local safety regulations must be observed during fault-finding.

#### Restarting after removal of a fault:

See chapter 7 "Putting into Operation" and the regulations for putting the drive source into operation.

#### Explanation of symbols for the following fault diagnosis:

\*1 - Have checked by a specialist.

\*2 - Refer to KAESER customer service.

#### 8.2.1 Abnormal running noises

##### Possible fault:

Backlash of the gears too large.

Bearing clearance too large.

Rotors out of time.

##### Removal:

Check the backlash. If it is  $> 0.1$  mm replace the timing gears; \*1 or \*2.

Measure the clearance, replace the bearing if necessary; \*1 or \*2.

Compare the conditions under use concerning pressure difference and speed with the delivery conditions. Check the rotor chamber for contamination and clean if necessary.

#### 8.2.2 Excessive blower temperature

##### Possible fault:

Operation with excessive pressure difference.

Contamination of the inlet filter causing degradation of volumetric efficiency.

Rotor clearance too large. Rotors and check with the manufacturer.

##### Removal:

Check the pressure difference and correct if necessary.

Clean inlet filter.

Measure the clearance between the rotor. Rotor replacement could be necessary; \*1 or \*2.

#### 8.2.3 Oil leaking into the air chamber

##### Possible fault:

Oil level too high.

Sealing rings worn.

##### Removal:

Drain the oil until the level is in the middle of the oil level sight glass.

Renew sealing rings.

## 8.2.4 Low inlet volume flow

### Possible fault:

Excessive rotor clearance caused by wear especially by heavily contaminated flow medium.

Inlet flow resistance too high.

### Removal:

Measure the clearance between the rotors and check with the manufacturer. Rotor replacement could be necessary; \*1 or \*2.

Clean the inlet filter.

## 9 Maintenance

### 9.1 Observe the following rules during all maintenance and service work:



Always ensure that personal protective measures are taken (e.g. the wearing of ear muffs) according to the accident prevention regulations.

Work on power driven equipment may only be carried out by trained or specialised personnel.

Before carrying out any maintenance work on the rotary blower, stop the blower lock out and tag out the main disconnect switch to prevent a restart. Isolate and de-pressurize the blower and attached piping to zero psig.

Ensure that no maintenance personnel are working on the rotary blower before restoring the power source.

See chapter 8.1 for restarting the rotary blower.



Ensure that all fuel and oil, auxiliary materials or agents and used parts are disposed of according to federal and local environmental regulations.

### 9.2 Regular Maintenance

Period	Work to be done	see chapter
200 hours after first putting into operation	change lubricating oil	9.4
monthly	check lubricating oil level*	9.3
1500 - 2500 hours*	change lubricating oil (mineral)	9.4
6000 – 8000 hours*	change lubricating oil (KAESER OMEGA synthetic)	9.4

\* The maintenance period can vary depending on the service and environmental conditions. The oil should be changed at least once a year, even if the blower was not in operation.

We highly recommend that a record is kept of the maintenance work done (see chapter 11.1).

### 9.3 Lubricating Oil Level Check / Topping up the Lubricating Oil

Check the lubricating oil level at the gear end and the drive end monthly and before every start with the rotary blower stationary. The oil level as seen at the oil level sight glass changes because of the rotating parts so that the lubricating oil level check must be carried out with the rotary blower stationary.

**Attention!**

If the lubricating oil level has fallen to  $\frac{1}{8}$ " below the center of the oil level sight glass the oil must be topped off according to the lubricating oil recommendations.

Never top off the oil to a level above the center of the sight glass otherwise oil can enter the air chamber.

**Attention!**

The oil chambers of the gear and drive ends are not connected to each other.



The lubricating oil, the rotary blower casing and ancillary parts can become extremely hot.

**Danger of burning!**

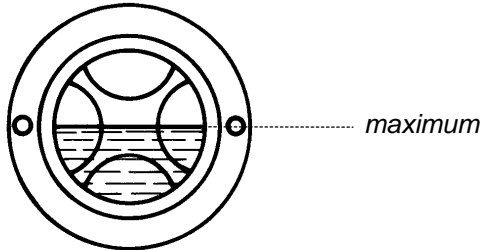

*Oil level sight glass*

**To check the lubricating oil level:**

- ☞ Stop the rotary blower (see chapter 8.1).
- ☞ Check the lubrication oil level at the oil level sight glass.

**To top up the lubricating oil:**

- ☞ Stop the rotary blower (see chapter 8.1) and lock out the power source to prevent a re-start.



**Danger of burning by hot components.**

**Wait until the rotary blower has cooled down to below 140 °F.**

- ☞ Open the corresponding oil filler by unscrewing the oil filler plug marked red (see also the sketch in chapter 5.1).

**Attention!**

**Use a screen filter or a freshly opened oil can when topping up the lubricating oil.**

- ☞ Top up the lubricating oil to the maximum level.
- ☞ Screw the oil filler plug marked red back in again.
- ☞ Carry out a visual check for leaks.

## 9.4 Lubricating Oil Change

Carry out the lubricating oil change with the rotary blower in a warm state (approximately 130 °F).

Carry out the first oil change after approximately 200 hours of service.

Carry out all further oil changes approximately every 1500 - 2500 service hours for mineral lubricants and approximately 6000 – 8000 service hours for synthetic lubricants or at least once annually.

- ☞ Stop the rotary blower (see chapter 8.1) and lock out the power source to prevent a re-start.





**Danger of burning by hot components.**  
**Wait until the rotary blower has cooled down to below 140 °F for.**

- ☞ Place a container ready to catch the used oil (see chapter 1.3 for the oil capacity).



**The used oil must be collected and disposed of according to federal and local environmental regulations.**

- ☞ Drain the oil by unscrewing the oil drain plug in the bottom of the casing.
- ☞ Open the corresponding oil filler by unscrewing the oil filler plug marked red (see also the sketch in chapter 5.1).
- ☞ Screw the oil drain plug back in again.
- ☞ Fill up with new lubricating oil (see chapter 9.3).
- ☞ Screw the oil filler plug marked red back in again.
- ☞ Carry out a visual check for leaks.

## 9.5 Cleaning the Rotary Blower

Because of the contact-free working principle of the rotors the clearances between the rotors and between the rotors and the casing allow, to a certain degree, the transport of a dusty mediums. Because of this fact, deposits can build up in the rotary blower.

- ☞ Stop the rotary blower (see chapter 8.1) and lock out the power source to prevent a re-start.



**Danger of burning by hot components.**  
**Allow the rotary blower to cool down to below 140 °F.**

- ☞ Remove ancillary components such as inlet and discharge silencers.
- ☞ Clean the air chamber and rotors of hard deposits and sticky layers using a solvent.

**Attention!**

**The type of solvent to use is determined by the type of contamination and the application process concerned.**

**Observe all references to safety, danger and environmental regulations.**

## 10 Spare Parts and After Sales Service

**Please quote the following data for all inquiries and spare part orders:  
(see also nameplate)**

1. Rotary blower, model:.....
2. Part number: .....
3. Serial number: .....
4. Description of the part: .....
5. Order number of the part:.....

Please provide the date of initial start-up when making claims under warranty!

**Important:** Transfer the data on the nameplate of the rotary blower into the nameplate (see chapter 1).



### 11.2 Safety information concerning contamination of compressors, blowers, vacuum pumps and components

#### Application and purpose

Every company is responsible for the health and safety of its employees. This extends to personnel who carry out servicing work at the company's premises or at the site of the user.

The attached declaration is intended to inform the service contractor of any possible contamination to be found in compressors, blowers, vacuum pumps or components sent to him for servicing. Based on this information, the service contractor can instigate the necessary protective measures when carrying out the service work.

#### Preparation for shipment

Before shipping the item(s), the sender should fill out and sign the attached Declaration of Contamination form (one for each item) and attach a copy to the shipping documents and a copy on the outside of the packaging.

#### Please note the following shipping regulations:

- drain all operating fluids
- remove filter elements
- make all openings airtight
- pack correctly
- ship in suitable container
- fix a copy of the Declaration of Contamination to the **outside** of the packaging



**Declaration of Contamination**  
concerning compressors, blowers, vacuum pumps and components

Repair and/or maintenance work will only be carried out on items for which a Declaration of Contamination form has been filled out and attached. **A completed Declaration is required for each item.** Any item not accompanied by a Declaration is liable to be returned untouched. Items that have been contaminated with microbiological, explosive or radioactive substances will only be accepted when accompanied by confirmation that they have been **fully decontaminated** according to regulation. This Declaration may only be filled out and signed by the authorized representative of the ordering party (sender of the item).

Sender/dept.: \_\_\_\_\_  
Contact name: \_\_\_\_\_  
Address: \_\_\_\_\_  
Phone / Fax: \_\_\_\_\_

Reason for sending the item:  
\_\_\_\_\_  
\_\_\_\_\_  
\_\_\_\_\_  
\_\_\_\_\_  
(use rear side of form if necessary)

**Specification of the item:**

Model/type name: \_\_\_\_\_  
Part no.: \_\_\_\_\_  
Serial no.: \_\_\_\_\_  
Oil used: \_\_\_\_\_

Accessories:  
\_\_\_\_\_  
\_\_\_\_\_

**Condition of the item:**

	yes	no	not known
- has it been used?	<input type="checkbox"/>	<input type="checkbox"/>	<input type="checkbox"/>
- emptied/vented?	<input type="checkbox"/>	<input type="checkbox"/>	<input type="checkbox"/>
- all openings airtight closed?	<input type="checkbox"/>	<input type="checkbox"/>	<input type="checkbox"/>
- cleaned / decontaminated?	<input type="checkbox"/>	<input type="checkbox"/>	<input type="checkbox"/>

Cleaning substance used: \_\_\_\_\_  
Cleaning method: \_\_\_\_\_

**Information on contaminants:**

- with what substances has the item been in contact?

	Trade name	Chemical name	Characteristics
a)			
b)			
c)			
d)			

	yes	no	not known
- Are the substances listed above hazardous to health?	<input type="checkbox"/>	<input type="checkbox"/>	<input type="checkbox"/>
- Are any hazardous substances given off by heating?	<input type="checkbox"/>	<input type="checkbox"/>	<input type="checkbox"/>

Which? \_\_\_\_\_

We declare that the information given in this declaration is true and complete and that the signatory is authorized and in a position to make this declaration. We are aware of our liability for any damages resulting from false or incomplete information given in this declaration and we engage to hold the contractor free of claims from third parties for compensation for damages resulting from such incomplete or false information.

Name of the authorized signatory (please print): \_\_\_\_\_

\_\_\_\_\_ Date \_\_\_\_\_ Authorized signature \_\_\_\_\_ Sender's company seal: \_\_\_\_\_