

## INSTRUCTION MANUAL

### KRD Series

Flow Rates: 100, 125, 150, 200, 250, 300, 400, 500 scfm

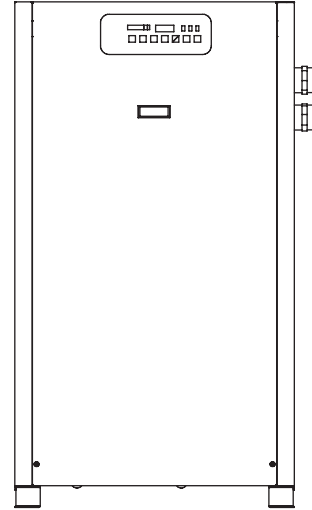

## CONTENTS

GENERAL SAFETY INFORMATION .....	2
RECEIVING, MOVING, AND UNPACKING .....	2
1.0 INSTALLATION.....	3
2.0 OPERATION.....	5
3.0 MAINTENANCE .....	8
SIZING.....	8
ENGINEERING DATA .....	9
WIRING DIAGRAM	
MODEL 100: 120/230 VAC .....	10
MODELS 125-150: 120/230 VAC .....	11
MODELS 200-500: 460 VAC.....	12-13
WIRING DIAGRAM: 575-460/3/60 TRANSFORMER PACK	
MODELS 200-500 .....	14
DIMENSIONS / WEIGHTS.....	15
TROUBLESHOOTING GUIDE	
MODELS 100-150 .....	16
MODELS 200-500 .....	17
PARTS LIST.....	18
WARRANTY .....	20

## REFRIGERATED

---

## TYPE

---

## COMPRESSED

---

## AIR DRYERS

---

## GENERAL SAFETY INFORMATION

### 1. PRESSURIZED DEVICES:

This equipment is a pressure containing device.

- Do not exceed maximum operating pressure as shown on equipment serial number tag.
- Make sure equipment is depressurized before working on or disassembling it for service.



### 2. ELECTRICAL:

This equipment requires electricity to operate.

- Install equipment in compliance with all applicable electrical codes.
- Standard equipment is supplied with electrical enclosures not intended for installation in hazardous environments.
- Disconnect power supply to equipment when performing any electrical service work.

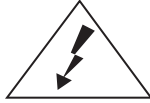

### 3. BREATHING AIR:

- Air treated by this equipment may not be suitable for breathing without further purification.

Refer to applicable standards and specifications for the requirements for breathing quality air.

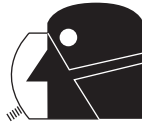

## RECEIVING, MOVING, AND UNPACKING

### A. RECEIVING

This shipment has been thoroughly checked, packed and inspected before leaving our plant. It was received in good condition by the carrier and was so acknowledged.

Check for Visible Loss or Damage. If this shipment shows evidence of loss or damage at time of delivery to you, insist that a notation of this loss or damage be made on the delivery receipt by the carrier's agent.

### B. UNPACKING

Check for Concealed Loss or Damage. When a shipment has been delivered to you in apparent good order, but concealed damage is found upon unpacking, notify the carrier immediately and insist on his agent inspecting the shipment. Concealed damage claims are not our responsibility as our terms are F.O.B. point of shipment.

### C. MOVING

In moving or transporting dryer, do not tip dryer onto its side.

### D. STORAGE/SHUT DOWN

**CAUTION** Dryer should not be stored outside (either packed or unpacked) or exposed to the weather. Damage to electrical and control components may result.

**IMPORTANT:** WATER-COOLED UNITS - If unit is shut down below freezing temperatures, the water-cooled condenser may freeze and cause permanent damage. Condenser must be drained when the unit is shut down.

**IMPORTANT:** Do not store dryer in temperatures above 130°F (54.4°C).

IMPORTANT: READ PRIOR TO STARTING THIS EQUIPMENT

## 1.0 INSTALLATION

### 1.1 Location

- A. For typical placement in a compressed air system, see drawing.
- B. Air compressor intake – Locate air compressor so that contaminants potentially harmful to the dryer (e.g. ammonia) are not drawn into the air system.
- C. Clearances Free air flow  
 Front 36 inches (914 mm)  
 Back 6 inches (152 mm)  
 Sides 36 inches (914 mm)  
 Service - To facilitate maintenance leave 36 inches (914 mm) of clearance in front of dryer.
- D. Standard units are designed to operate in ambients:  
 Air-cooled: 45 to 110°F (7 to 43°C).  
 Water-cooled: 45 to 130°F (7 to 54°C).
- E. Installations in altitudes above 4500 feet (1370 meters) –  
 Dryer is adjusted to operate in altitudes up to 4500 feet (1370 meters). If dryer is installed in an altitude above this, and has not been preset at the factory for this altitude, contact manufacturer's Service Department.
- F. The installation of a flexible connection prior to the dryer is recommended to prevent possible damage from vibration.

NOTE: Outdoor installation – Standard units are designed for indoor installation. Contact manufacturer if installing outdoors.

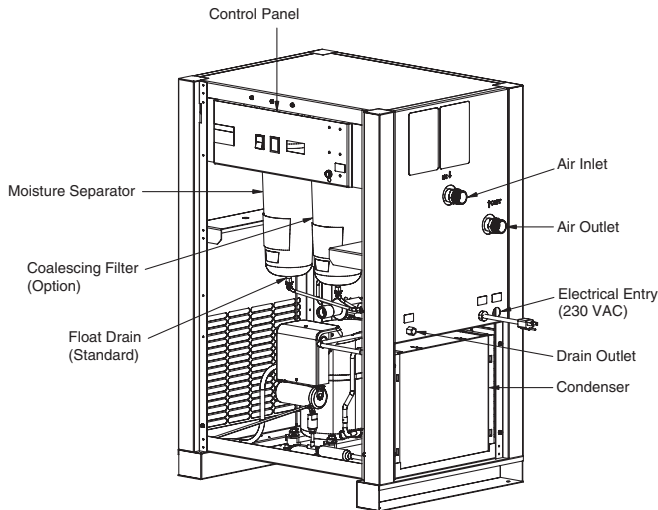
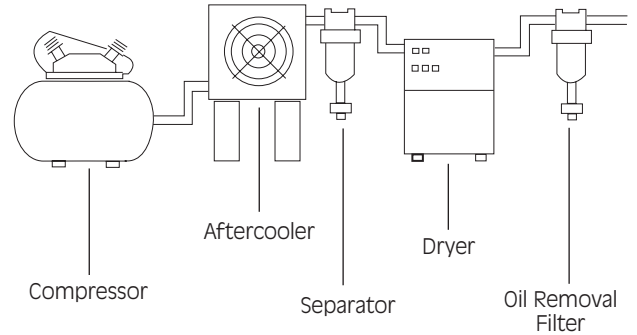

Models 100, 125, & 150

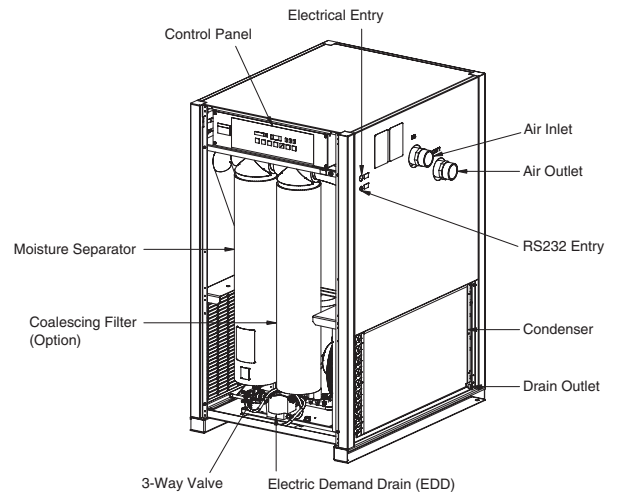

Models 200, 250, 300, 400, & 500

## 1.2 Mounting

Mount the dryer on a level solid surface. Holes are provided in the dryer base to permanently mount the dryer to the floor.

## 1.3 Piping connections

- A. Air Inlet - Connect compressed air line from air source to air inlet. (Reference markings on dryer or see callout drawing on page 12 for air inlet/outlet connection locations.)

**⚠ WARNING** Refer to Serial Number Tag for maximum working pressure. Do not exceed dryer's Maximum Working Pressure.

NOTE: Install dryer in air system at highest pressure possible (e.g. before pressure reducing valves).

NOTE: Install dryer at coolest compressed air temperature possible. Maximum inlet compressed air temperature: 120°F (49°C). If inlet air exceeds this temperature, precool the air with an aftercooler.

- B. Air Outlet – Connect air outlet to downstream air lines.
- C. Bypass piping – If servicing the dryer without interrupting the air supply is desired, piping should include inlet and outlet valves and an air bypass valve.
- D. Water cooled models – cooling water inlet and outlet
1. Connect cooling water supply to cooling water inlet.
  2. Connect cooling water return line to cooling water outlet connection.

NOTE: Strainer and water regulating valve are supplied on water cooled models.

## 1.4 Electrical connections

IMPORTANT: Use copper supply wires only.

- A. Dryer is designed to operate on the voltage, phase, and frequency listed on the serial number tag.
- B. If dryer is supplied with a cord and plug, install in a receptacle of proper voltage.
- C. Electrical entry on larger dryers is through a hole in the cabinet. It is located on the right side panel when facing the front of the unit. Connect power source to terminal strip in electrical enclosure as shown on the wiring diagram included with the dryer.

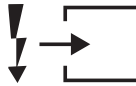

NOTE: Refrigeration condensing unit is designed to run continuously and should NOT be wired to cycle on/off with the air compressor.

NOTE: ON MODEL 500, CHECK FOR CORRECT PHASING OF UNIT. After starting the dryer, if an unusual noise is heard, or if the discharge line does not get hot, the refrigeration compressor may be running in the reverse direction. Immediately stop the dryer, reverse two of the power leads, restart the dryer, and verify the unusual noise is corrected and the refrigerant discharge line is hot. FAILURE TO DO SO MAY DAMAGE THE COMPRESSOR AND VOID THE WARRANTY.

## 1.5 Moisture separator

- A. Models 100-150:  
Separator (and Oil Removal Filter where applicable) has an internal drain which automatically discharges condensate.

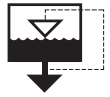

Models 200-500:  
Separator (and Oil Removal Filter where applicable) has an electronic demand drain (EDD) which automatically discharges condensate.

NOTE: It may be desirable to pipe the condensate from the Automatic Drain outlet to a suitable drain.

- B. Models 100-150:  
Separator has a knurled fitting with flexible drain tubing attached. Be sure knurled fitting is tightened by turning counter-clockwise before operating dryer.

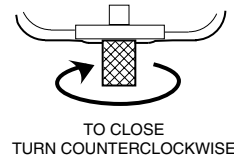

- C. Models 200-500  
For manual draining, convenient dryer depressurization, and EDD service, a three-way valve assembly has been installed at the bottom of the moisture separator (and cold coalescing filter where applicable). Review the following for proper drain function:

- Automatic Draining - Valve handle should be positioned parallel to the valve body (as shown), with the arrow on the handle pointing toward the EDD. In this position, condensate will flow from the bowl to the EDD.
- Drain Isolation (Shutdown) - Valve handle shall be turned perpendicular to the valve body (rotate 90°). In this position, condensate flow is shutoff.

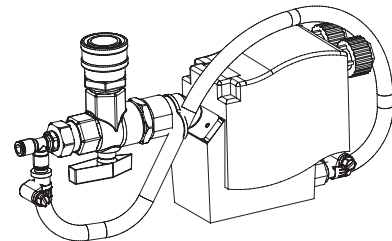

- Manual Draining - Drain valve handle shall be rotated slightly past the drain isolation position to allow throttling through the valve for manual discharge and depressurization.
- Note: The quick disconnect fitting allows removal of the entire drain assembly. **However, the unit must be depressurized prior to disassembly or serious injury may occur.**

NOTE: Discharge is at system pressure. Drain line should be anchored.

NOTE: Condensate may contain oil. Comply with applicable laws concerning proper disposal.

## 1.6 Operation

- A. Verify that isolation valves are open. If the drain fails to discharge after the valve is energized, the electronic control circuit will repeatedly energize the valve in an attempt to clear the discharge port. If, after 60 seconds,

the drain still fails to discharge, the control circuit then switches to the alarm mode. In this mode the valve is de-energized and the red alarm light is activated on the drain and the dryer controller. The valve is then automatically energized every 4 minutes for 5 seconds. Check the drain operation. Push drain (push-to-test) button on the Energy Management Monitor control board to energize drain. A flow of condensate and/or air should be present at the drain outlet. The alarm mode automatically clears after the drain returns to normal operation.

- B. Condensate enters the reservoir (1) through the inlet port. When the condensate level in the reservoir covers the capacitance sensor, an electronic signal is sent to the solid state countdown processor. The processor delays the opening of the solenoid valve for a given period of time. Once the time has elapsed, the solid state processor transmits information to energize the coil in the solenoid valve (2). The magnetic force of the coil causes the solenoid core (3) to move, closing the pilot air supply line and opening the pilot air exhaust line. After the pilot air above the diaphragm (4) is vented, pressure in the reservoir opens the discharge port and forces the condensate through the discharge port and outlet piping.

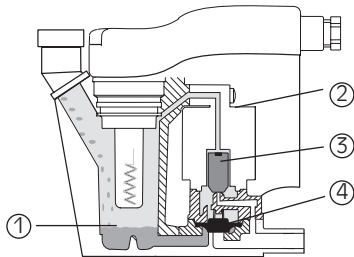

## 2.0 OPERATION

### 2.1 Minimum/Maximum operating conditions

- A. Maximum inlet air pressure: refer to dryer serial number tag
- B. Minimum inlet air pressure: 30 psig (2.1 kgf/cm<sup>2</sup>)
- C. Maximum inlet air temperature: 120°F (49°C)
- D. Maximum ambient temperature:  
Air-cooled models: 110°F (43°C)  
Water-cooled models: 130°F (54°C)
- E. Minimum ambient temperature: 45°F (7°C)

### 2.2 Start-up

- A. Models 100-150:  
Energize compressor by positioning the on/off switch in the on (I) position. Compressor on light will illuminate.

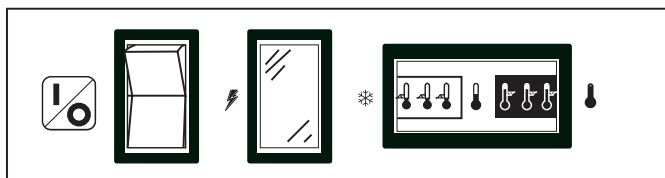

On/Off Switch    Power-On Light    Dewpoint Indicator (Green)

- B. Models 200-500:  
Energize dryer. Green power on light will illuminate.

**IMPORTANT:** Energize dryer disconnect switch (provided by others, see NEC) 24 hours before refrigeration compressor is started! Never use the disconnect switch to shutdown the dryer for an extended period of time (except for repair). Failure to follow these instructions may result in a non-warrantable compressor failure.

**NOTE:** If there is no power to the control board for a period of two weeks or more, it may return to the default mode.

### C. Program Monitor

Press and hold Program Mode button until Main Menu screen appears. Use the Up and Down arrow buttons to scroll through the list of submenu choices. Press Enter button to view the submenu that is displayed. Press ESC to exit the Main Menu and return to Display mode.

1. Language selection
  - a. Use the 'Up' and 'Down' arrow buttons to scroll through the list of languages (choice of 10 available: English, Deutsch, Francais, Espanol, Italiano, Polski, Dansk, Dutch, Norsk and Suomi).
  - b. Press 'Enter' button to select the language that is displayed.
  - c. Push 'ESC' at any time to return to the Main Menu.
2. Setting Date & Time
  - a. Use the 'Up' and 'Down' arrow buttons to set minutes (00 to 59). Press 'Enter' to accept new value.
  - b. Use the 'Up' and 'Down' arrow buttons to set hours (00 to 23). Press 'Enter' to accept new value.
  - c. Use the 'Up' and 'Down' arrow buttons to set year (00 to 99 representing 2000 to 2099). Press 'Enter' to accept new value.
  - d. Use the 'Up' and 'Down' arrow buttons to set month (three letter abbreviation). Press 'Enter' to accept new value.
  - e. Use the 'Up' and 'Down' arrow buttons to set day (01 to maximum for the month and year selected). Press 'Enter' to accept new value.
  - f. Push 'ESC' at any time to return to the Main Menu.
3. Setting Schedule
  - a. Use the 'Up' and 'Down' arrow buttons to select desired "Day of week + on/off". Press 'Enter' to accept new value
  - b. Use the 'Up' and 'Down' arrow buttons to set hour (00 to 23). Press 'Enter' to accept new value  
 Note: If the hour setting is 'IGNORE', Press 'Enter' again to move the cursor under the "Day of week + on/off". Repeat steps a through b (or c) as needed.
  - c. Use the Up and Down arrow buttons to set minutes (00, 10, 20, 30, 40, 50; not shown if hour setting is 'IGNORE'). Press 'Enter' to accept new value and return to "Day of week + on/off". Repeat steps a through c as needed.
  - d. Push 'ESC' at any time to return to the Main Menu.  
 NOTE: Scheduler will ignore programmed commands for 10 minutes after exiting program mode.

#### 4. Hours To Service

- a. Use the 'Up' and 'Down' arrow buttons to scroll through the range of permissible values (0 to 8760) before service reminder is initiated. Press 'Enter' to accept new value. (Only hours that refrigeration compressor is operating are counted).
- b. Press 'ESC' at any time to return to the Main Menu.

NOTE: On dryers with air-cooled condensers, regular condenser cleaning is recommended. Dirtiness of ambient air at installation site will determine frequency of service. Typically once a month is recommended. Dryers contain an integral 3 micron filter. As the filter element accumulates solid contaminants, differential pressure increases. Solid particulate load in the compressed air supply will determine frequency of service. Typically element changeout is recommended at least annually.

#### 5. Push ESC button to exit program mode

NOTE: If after 60 seconds no button is pressed while in Program Mode, the audible alarm sounds for five (5) seconds. Dryer will resume previous operating mode.

#### 6. Manual Operation

- a. To manually turn the refrigeration system on or off use 'On/Off' button; Push 'Schedule On/Off and Enter' button to return to schedule.

NOTE: After power interruption dryer will reenergize in Manual override, refrigeration system off. To restart Schedule: Push 'Schedule On/Off and Enter' button.

#### C. Starting dryer

**IMPORTANT:** Dryer must be energized 24 hours before starting refrigeration compressor.

NOTE: It is recommended that dryer be started 15 minutes before compressed air flow begins.

1. On water-cooled models: after 24 hours, begin cooling water flow.
2. Check for proper electrical voltage.
3. Slowly pressurize unit air side by opening inlet isolation valve. Check for leaks.
4. After 15 minutes, open outlet isolation valve slowly.
5. Close air bypass valve.
6. Dryer may be operated in Manual or scheduled modes.

NOTE: ON MODEL 500, CHECK FOR CORRECT PHASING OF UNIT. After starting the dryer, if an unusual noise is heard, or if the discharge line does not get hot, the refrigeration compressor may be running in the reverse direction. Immediately stop the dryer, reverse two of the power leads, restart the dryer, and verify the unusual noise is corrected and the refrigerant discharge line is hot. FAILURE TO DO SO MAY DAMAGE THE COMPRESSOR AND VOID THE WARRANTY.

Manual mode - push On/Off button - refrigeration compressor will start and run, green Compressor-on light will illuminate. In this mode compressor will run continuously and will not be turned on and off by the monitor. MANUAL OVERRIDE will appear on interface panel.

### CONTROL PANEL

The diagram shows a control panel with the KAESER logo on the left. It features a temperature indicator (1) with a scale from 32°F to 4°C. To its right is a large operator interface display (2). Further right are five indicator lights: Power-on (3), Compressor-on (4), Alarm/Service (5), Schedule On/Off and Enter (6), and On/Off (10). Below these are seven buttons: Schedule On/Off and Enter (6), ESC (7), Up Arrow (8), Down Arrow (9), On/Off (10), Alarm/Service (5), and a circular button (11). A website URL www.kaeser.com is printed at the bottom right of the panel.

1. Temperature Indicator
2. Operator Interface Display
3. Power-on Light
4. Compressor-on Light
5. Alarm / Service Light
6. Schedule On/Off and Enter Button
  - a. In display mode: Press to toggle between SCHEDULE RUNNING and MANUAL OVERRIDE.
  - b. In program mode:
    - i. Press to move to a lower level menu.
    - ii. Press to accept a value that has been edited.
7. Program Mode (i) and Esc
  - a. In display mode: Press and hold to enter program mode.
  - b. In program mode: Press to move to a higher level menu.
8. Up Arrow
  - a. In display mode: No function
  - b. In program mode:
    - i. Press to view the next item in a list or to increment a variable to a higher value. Press and hold for accelerated incrementing.
    - ii. When the top of the list (or highest value) is displayed, pressing the up button will cause the display to wrap to the bottom of the list (or lowest value).
9. Down Arrow
  - a. In display mode: No function
  - b. In program mode:
    - i. Press to view the previous item in a list or to increment a variable to a lower value. Press and hold for accelerated incrementing.
    - ii. When the bottom of the list (or lowest value) is displayed, pressing the down button will cause the display to wrap to the top of the list (or highest value).
10. I/O: Press at any time to turn the dryer on/off.
11. Drain test: Press at any time to momentarily the open drains (like the current emm).
12. Reset: Press at any time to clear the alarm/service message (if shown) and the alarm LED.

Schedule mode - push Schedule On/Off and Enter button. SCHEDULE RUNNING will appear on the interface panel. The refrigeration compressor will continue to be on or off (as selected in the Manual Override Mode) until the next scheduled event. The compressor will then turn on or off as programmed.

NOTE: Schedule may be returned to the manual mode at any time using the 'Schedule On/Off and Enter' button. MANUAL OVERRIDE will appear on interface panel. To reinstitute Schedule, push the 'Schedule On/Off and Enter' button again.

NOTE: Restart after the power interruption. Unit will be in MANUAL OVERRIDE mode, refrigeration compressor, off when power is restored after power interruption.

7. To reinstitute SCHEDULE RUNNING, push 'Schedule On/Off and Enter' button.

IMPORTANT: Dryer must be energized 24 hours before refrigeration compressor is started

#### D. Operating check points

1. Check that green Power-on light is illuminated
2. Check that green Compressor-on light is illuminated if dryer is on in the manual mode or it is a scheduled on time

IMPORTANT: Refrigeration compressor must be restarted after power interruption.

3. Check interface panel

NOTE: Interface panel will scroll through three screens (Current Time/Operating Status, Hours to Service and Total Operating Hours).

- a. Verify that current time is correct
- b. Check HRS TO SERVICE: this indicates time remaining until service is required; allow time for required maintenance items to be ordered
- c. Check operating status:

MANUAL OVERRIDE - Dryer is either running continuously (not being controlled by the scheduled on/off times) or the refrigeration compressor has been shut off using the 'On/Off' button.

SCHEDULE RUNNING - Refrigeration compressor is being turned on and off by the monitor per-programmed schedule (see B.3. to set schedule).

- d. Check Temperature indicator - indicator should read in the green area.
- e. Check Alarm/Service light If illuminated, check Interface panel.
  - 1) If SERVICE DRYER appears, scheduled maintenance time has elapsed (HRS TO SERVICE is 0). Perform needed service and reset service interval (see B.3.).
  - 2) If ALARM appears, a dryer fault is indicated; see Troubleshooting Guide for possible remedies. After fault correction push Reset button to turn Fault alarm off.

Type of FAULTS:

LOW PRESSURE - the refrigeration compressor control circuit has opened because of low suction pressure.

HIGH PRESSURE - the refrigeration compressor control circuit has opened because of high head pressure. The high pressure switch must be reset manually once the fault is corrected. Red reset button is located on pressure switch inside unit.

HIGH TEMPERATURE - compressed air temperature is above the set point.

COMPRESSOR - Normally open (NO) auxiliary contact on the compressor contactor is open when the dryer is on.

HEATER - Normally closed (NC) auxiliary contact on the compressor contactor is open when the dryer is off.

TEMP SENSOR - Occurs if the temperature sensor circuit is open or shorted. If open, the left-most LED in the temperature display will be illuminated. If shorted, all the LEDs in the temperature display will be illuminated.

DRAIN - electric drain contains a high water level alarm that activates if drain fails to discharge.

- f. Check drain operation - push Drain (push-to-test) button to energize electric drain. A flow of condensate and/or air should be present at the drain outlet.

#### E. Using the RS-232 port

The RS-232 port is used to monitor dryer operation from a host computer. A (1 to 1) DB-9 cable is required to connect dryer and computer. For PC connections, data is transmitted on pin 2, received on pin 3, ground is pin 5, pins 7 and 8 are jumpered at dryer.

Operation is at fixed baud rate of 9,600; asynchronous format is 8 bit, no parity, 1 stop bit ("8,N,1"). No check sum or error correction values are provided. If required, request status string two (or more) times and compare for agreement.

Request data by sending ASCII ? character (3FH). Response may take up to two seconds as certain processing functions may require completion before serial port is acknowledged.

Dryer responds with line feed (OAH), carriage return (ODH), and character string: (1), (2), (3), (4), (5), (6), (7), (8), (9)

- (1) = STX (start-of-text character, may appear as a smiley face or some other character)
- (2) = 108, Control board ID
- (3) = 0 or 1, Compressor running status (0=off, 1=on)
- (4) = M or S, Operating Mode (M= MANUAL OVERRIDE, S = SCHEDULE RUNNING)
- (5) = xxxx, HOURS TO SERVICE
- (6) = xxxxxx, TOTAL HOURS
- (7) = xx, Alarm or Service Code (0=no alarm, 30=LOW PRESSURE ALARM, 31=HIGH PRESSURE ALARM, 32=COMPRESSOR ALARM, 36=HIGH EVAP TEMP ALARM, 37=HEATER ALARM, 38=DRAIN ALARM, 39=SERVICE DRYER, 41=TEMP SENSOR ALARM)
- (8) = xx.x, Evaporator temperature (°F)
- (9) = ETX, (end-of-text character, may appear as a heart or some other character)

### 3.0 MAINTENANCE

- 3.1 Condenser coil – Clean off accumulated dust and dirt monthly.
- 3.2 Moisture separator – Replace filter element when pressure drop across dryer is excessive or annually.
- 3.3 Check separator daily to be sure automatic drain is discharging.
- 3.4 Blow down separator weekly by pushing test button on control panel.
- 3.5 Rebuild drain mechanism annually.

To facilitate service, maintenance kits are available.

Models 100-150

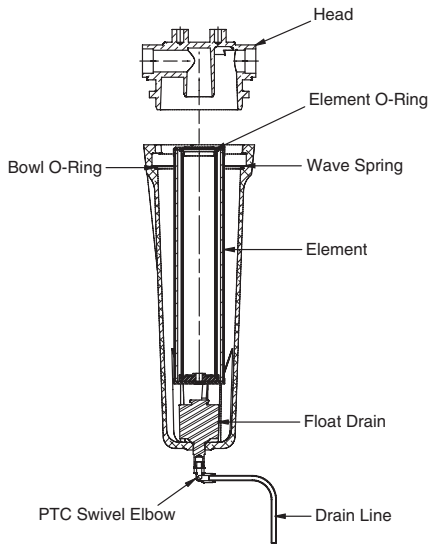

Models 200-500

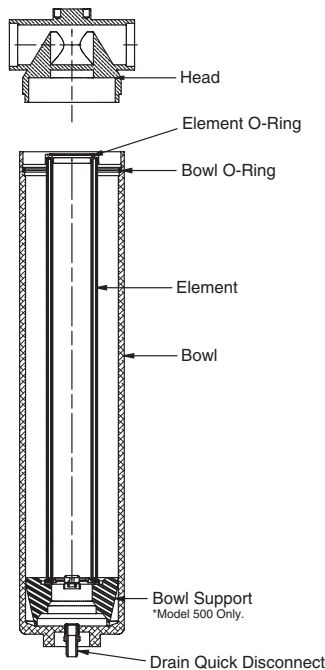

### SIZING

Determining dryer capacity at actual operating conditions

To determine the maximum inlet flow capacity of a dryer at various operating conditions, multiply the rated capacity from Table 1 by the multipliers shown in Table 2.

Example: How many scfm can an air-cooled model 400 handle when compressed air to be dried is at 200 psig and 100°F; ambient air temperature is 80°F?

Answer: 400 x 1.22 x 1.12 = 547 scfm.

**TABLE 1**

Rated capacity (scfm) and pressure drop @ 100 psig inlet pressure, 100°F inlet temperature, and 100°F ambient temperature

MODEL		100	125	150	200	250
Rated capacity of air-cooled models (scfm)	60 Hz	100	125	150	200	250
	50 Hz	84	105	125	170	210

MODEL		300	400	500
Rated capacity of air-cooled models (scfm)	60 Hz	300	400	500
	50 Hz	250	340	420

**TABLE 2**

Air capacity correction factors (Multipliers)

INLET PRESSURES		INLET COMPRESSED AIR CONDITIONS				
		INLET TEMPERATURES				
psig	kgf/cm <sup>2</sup>	80°F 27°C	90°F 32°C	100°F 38°C	110°F 43°C	120°F 49°C
50	3.5	1.35	1.05	0.84	0.69	0.56
80	5.6	1.50	1.17	0.95	0.79	0.66
100	7.0	1.55	1.23	1.00	0.82	0.70
125	8.8	1.63	1.31	1.07	0.91	0.74
150	10.5	1.70	1.37	1.13	0.95	0.80
175	12.3	1.75	1.42	1.18	0.99	0.84
200	14.0	1.80	1.47	1.22	1.03	0.89

AMBIENT TEMPERATURE		MULTIPLIER
°F	°C	
80	27	1.12
90	32	1.06
100	38	1.00
110	43	0.94

\*Air-cooled models; water-cooled models use 1.15 multiplier if cooling water is below 35°C, 95°F.



# ENGINEERING DATA

Air System Data								
Rated Flow Capacity at 100°F, 100 psig Inlet, 100°F Ambient Temperature	100	125	150	200	250	300	400	500
Maximum / Minimum Inlet Air Pressure (compressed air at inlet to dryer)	232 psig (16 barg) / 30 psig (2 barg)							
Maximum / Minimum Inlet Air Temperature (compressed air at inlet to dryer)	120°F (49°C) / 40°F (4°C)							
Maximum / Minimum Ambient Temperature	110°F (43°C) / 40°F (4°C)							
Outlet Air Temperature (nominal at rated conditions)	85°F (29°C)							
Refrigeration System Data								
Refrigeration Capacity @ 35°F Evaporator & 100°F Ambient (BTU/hr)	60 Hz	4820	7130	8900	15200			19200
	50 Hz	4020	7340	7420	12700			16000
Refrigerant Type	R-134A							
Refrigerant Charge	See Data Tag on Dryer							
Suction Pressure Setting - Hot Gas Bypass Valve (psig)	30.5 psig (2.1 barg)							
Compressor Control Ranges (out-in)	High	N/A		281 - 190 psig (19.4 - 13.1 barg)				
	Low	N/A		22 - 34 psig (1.5 - 2.3 barg)				
Air-Cooled Condensers								
Air Flow Across Condenser (cfm) (air-cooled models)	60 Hz	300	450	710	1070			2470
	50 Hz	250	370	590	890			2060
Condenser Fan Switch Setting (in-out)	Fan 1	110 - 70 psig (7.6 - 4.8 barg)			113 - 78 psig (7.8 - 5.4 barg)			
	Fan 2	N/A						183 - 124 psig (12.6 - 8.6 barg)
Water-Cooled Condensers								
Water Regulating Valve Setting	135 psig (9.3 barg)							
Required Available Water Pressure Differential	40 psig (2.8 barg) - minimum							
Flow Required with 85°F Cooling Water (gallons per minute)	60 Hz	N/A		1.1	2.0		2.1	
	50 Hz	N/A		0.9	1.7		1.8	
Electrical Data								
Nominal Voltage	115/1/60			208-230/3/60				
Min. - Max. Voltage	104 - 127			187 - 253				
Input Power @ Rated Flow (watts)	932	1280	1298	1255	1962	1999	2031	2680
Rated Load Amps**	10.2	13.0		7.5	10.4			11.4
Locked Rotor Amps**	51.0	70.		51.0	66.0			75.0
Minimum Circuit Ampacity	13.6	18.0		10.5	15.9			20.0
Branch Circuit Fuse Size (amps)	20	25		15	20			25
Resistance (ohms)	4.3 S/0.7 R	3.2 S/0.4 R		1.8	1.3			1.1
Nominal Voltage	208-230/1/60			460/3/60				
Min. - Max. Voltage	187 - 253			414 - 506				
Input Power @ Rated Flow (watts)	932	1280	1298	1255	1962	1999	2031	2680
Rated Load Amps**	5.4	6.5		3.6	4.7			5.1
Locked Rotor Amps**	30.0	35.0		25.0	33.0			40.0
Minimum Circuit Ampacity	7.3	9.1		5.2	7.5			9.6
Branch Circuit Fuse Size (amps)	15	15		15	15			15
Resistance (ohms) Main/Start	9.0 S/2.3 R	7.9 S/1.6 R		7.4	5.0			4.1
Nominal Voltage	100/1/50			575/3/60				
Min. - Max. Voltage	90 - 110			518 - 633				
Input Power @ Rated Flow (watts)	680	1019	991	1255	1962	1999	2031	2680
Rated Load Amps	10.2	13.0		3.6	4.7			5.1
Locked Rotor Amps	51.0	70.0		25.0	33.0			40.0
Minimum Circuit Ampacity	13.6	18.0		4.2	6.0			7.7
Branch Circuit Fuse Size (amps)	20	25		15	15			15
Resistance (ohms)	4.3 S/0.7 R	3.2 S/0.4 R		7.4	5.0			4.1
Nominal Voltage	240/1/50			380-420/3/50				
Min. - Max. Voltage	216 - 264			342 - 462				
Input Power @ Rated Flow (watts)	680	1019	991	1002	1613	1622	1667	1992
Rated Load Amps**	4.5	5.0		3.6	4.7			5.1
Locked Rotor Amps**	21.0	30.0		25.0	33.0			40.0
Minimum Circuit Ampacity	6.2	7.3		5.2	7.5			8.1
Branch Circuit Fuse Size (amps)	15	15		15	15			15
Resistance (ohms)	19.5 S/3.3 R	10.5 S/1.8 R		7.4	5.0			4.1

\* For 60 Hz, 35°F Evaporator, 100°F Ambient; for 50Hz, 35°F Evaporator, 77°F Ambient

\*\* Compressor Only

# WIRING DIAGRAM

Model 100: 120/230 VAC

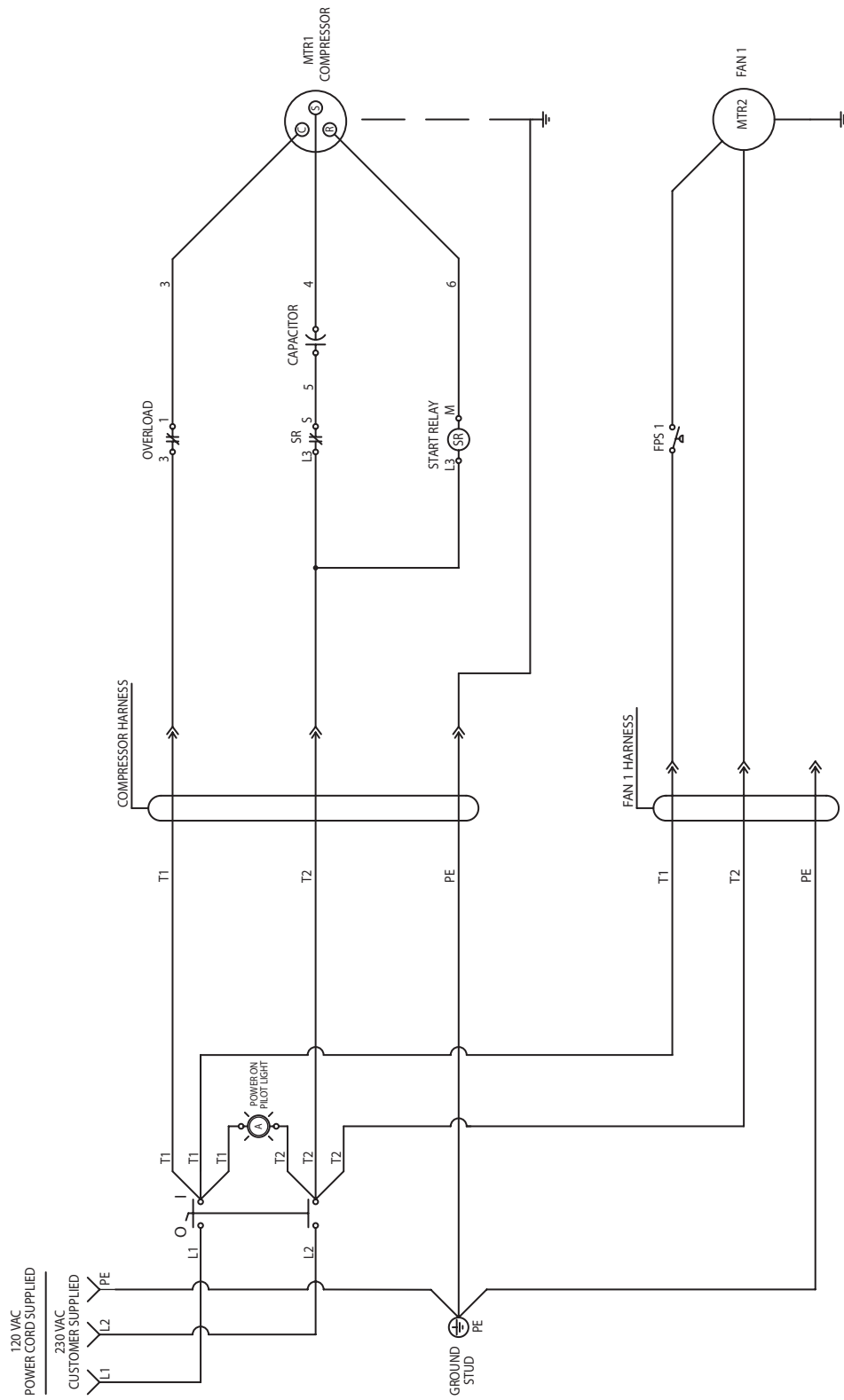

# WIRING DIAGRAM

Models 125-150: 120/230 VAC

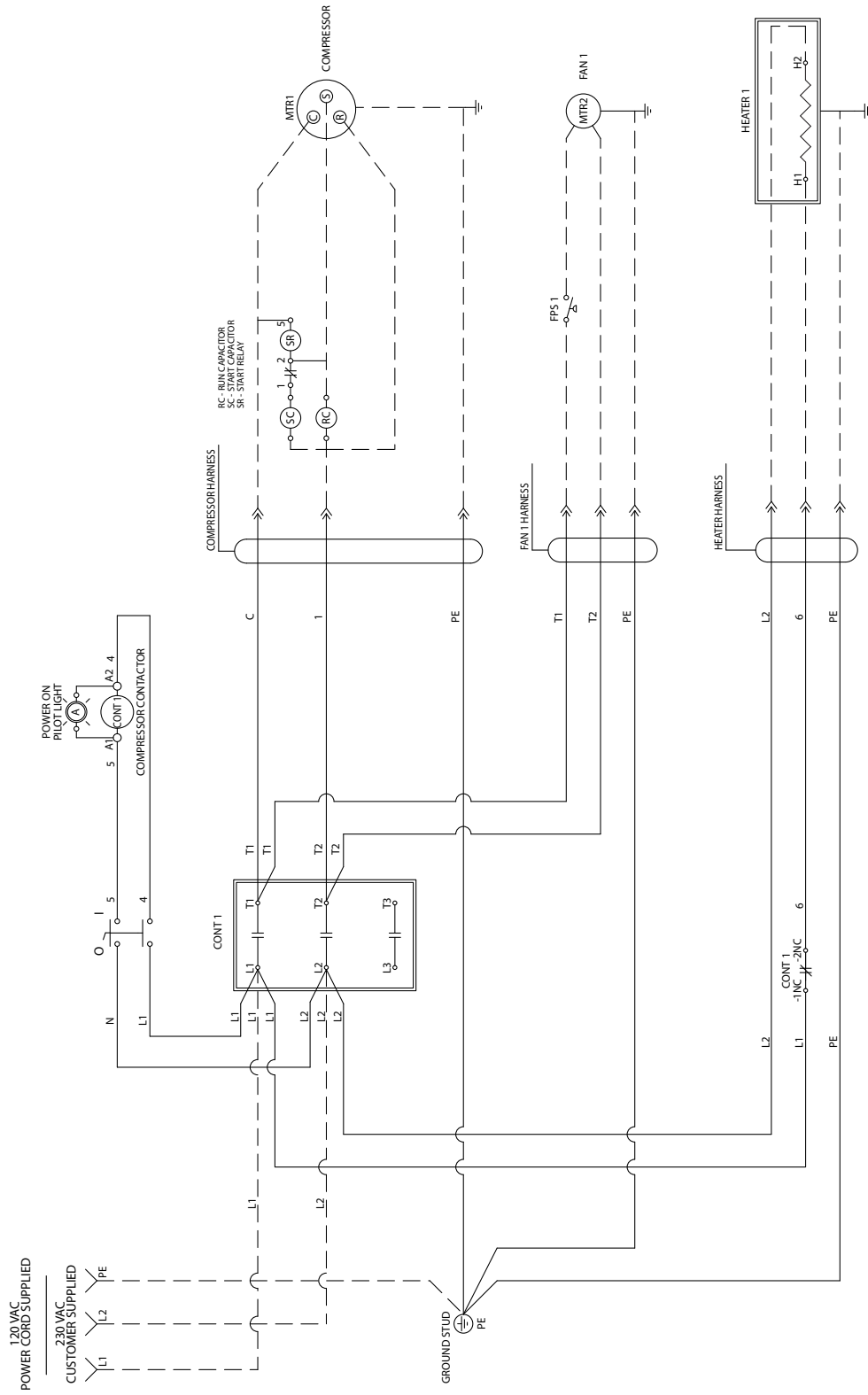

# WIRING DIAGRAM

Models 200-500 - 460 VAC  
Sheet 1 of 2

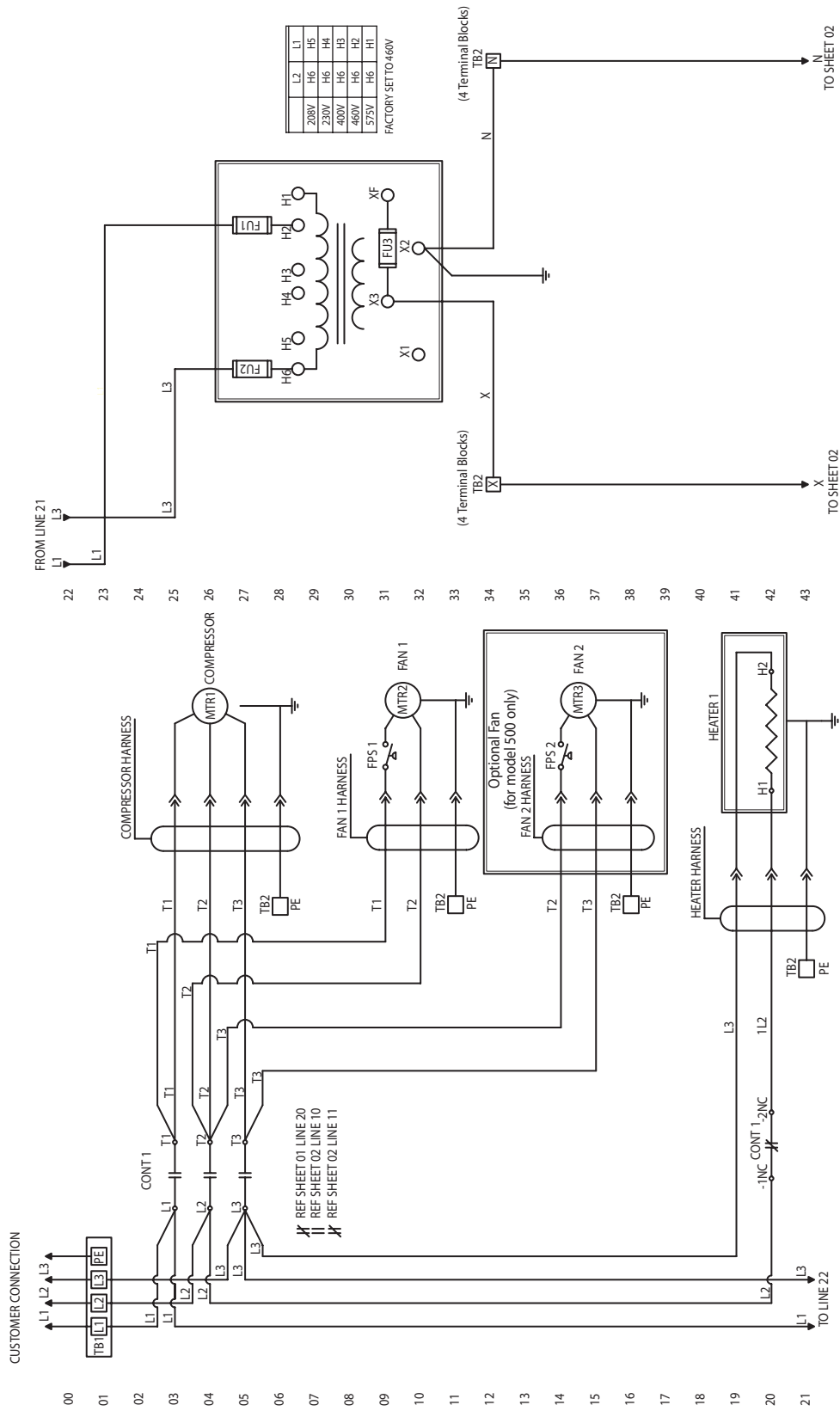

# WIRING DIAGRAM

Models 200-500 - 460 VAC  
Sheet 2 of 2

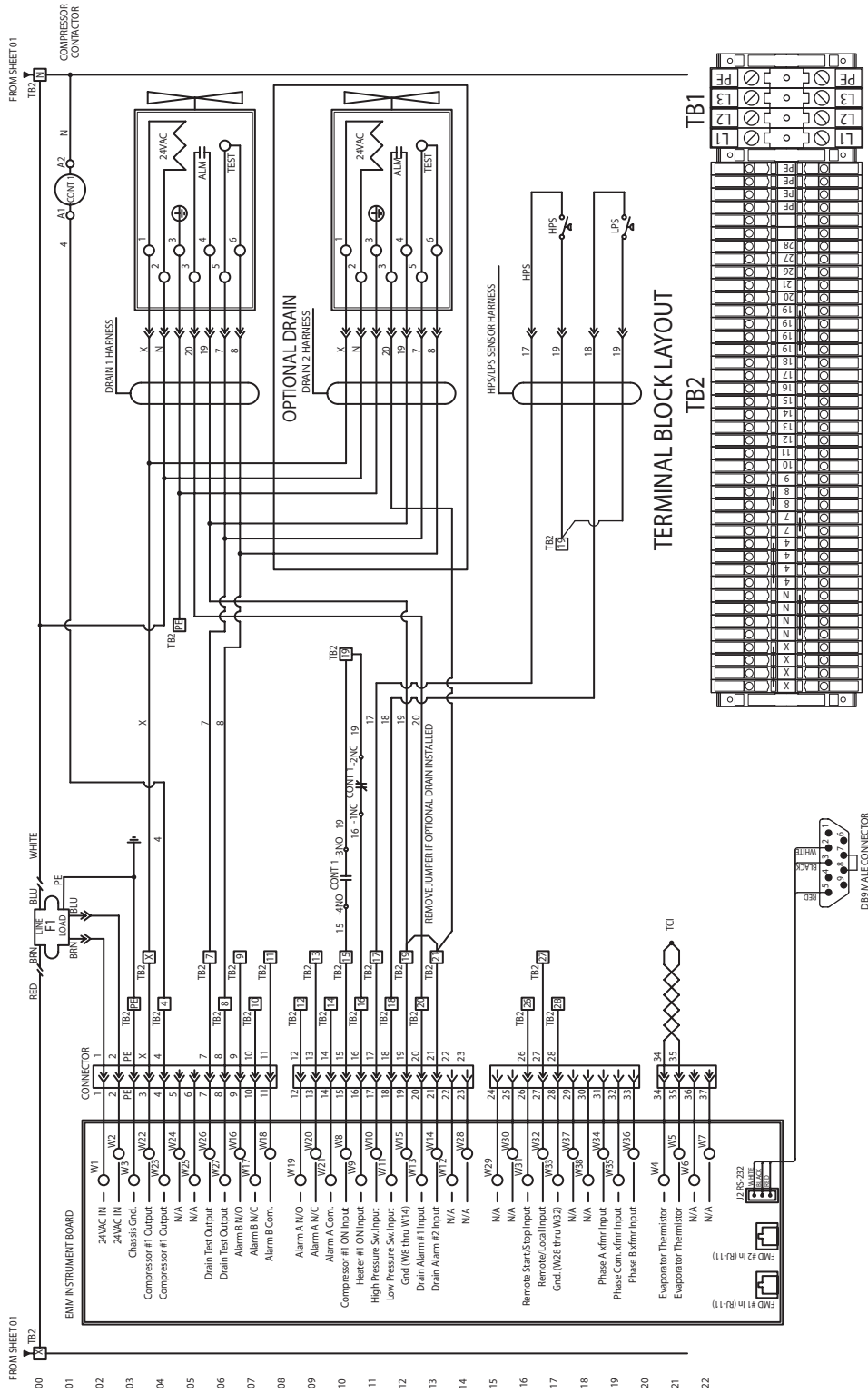

# WIRING DIAGRAM

Models 200-500, 575-460/3/60 Transformer Pack

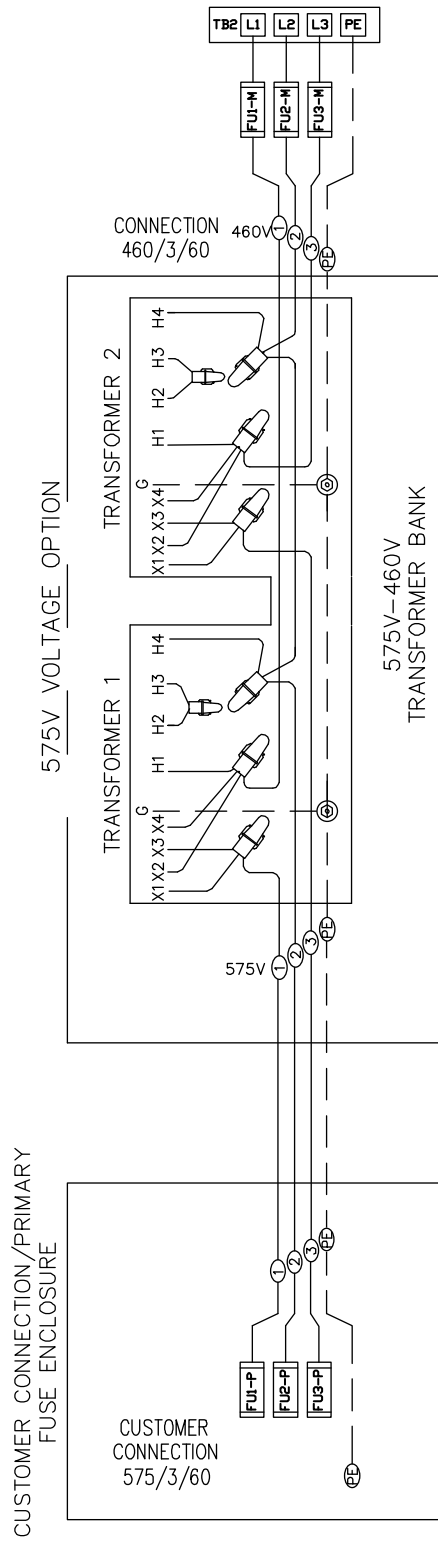

# DIMENSIONS / WEIGHTS

Dimensions (inches)								
MODEL	100	125	150	200	250	300	400	500
A	37.56	37.56	37.56	38.60	38.60	45.38	45.38	58.06
B	25.62	25.62	25.62	32.15	32.15	32.15	32.15	32.15
C	1.63	1.63	1.63	1.88	1.88	2.63	2.63	2.77
D	23.62	23.62	23.62	30.15	30.15	30.15	30.15	30.15
E	17.62	17.62	17.62	30.16	30.16	30.15	30.15	39.62
F	19.62	19.62	19.62	32.15	32.15	32.15	32.15	41.62
G	9.58	9.58	9.58	7.64	7.64	13.51	16.25	20.44
H	14.96	14.96	14.96	15.80	15.80	21.82	25.68	27.79
I	28.54	28.54	28.54	30.19	30.19	29.98	36.89	49.06
J	25.02	25.02	25.02	26.04	26.04	25.74	32.82	44.78
K	0.31	0.31	0.31	0.31	0.31	0.31	0.31	0.63
L INLET/OUTLET CONNECTIONS	1	1	1	1-1/2	1-1/2	1-1/2	2	2-1/2
WEIGHT (LBS)	251	273	279	425	463	527	571	684

NOTE: Dimensions and Weights are for reference only. Request certified drawings for construction purposes.

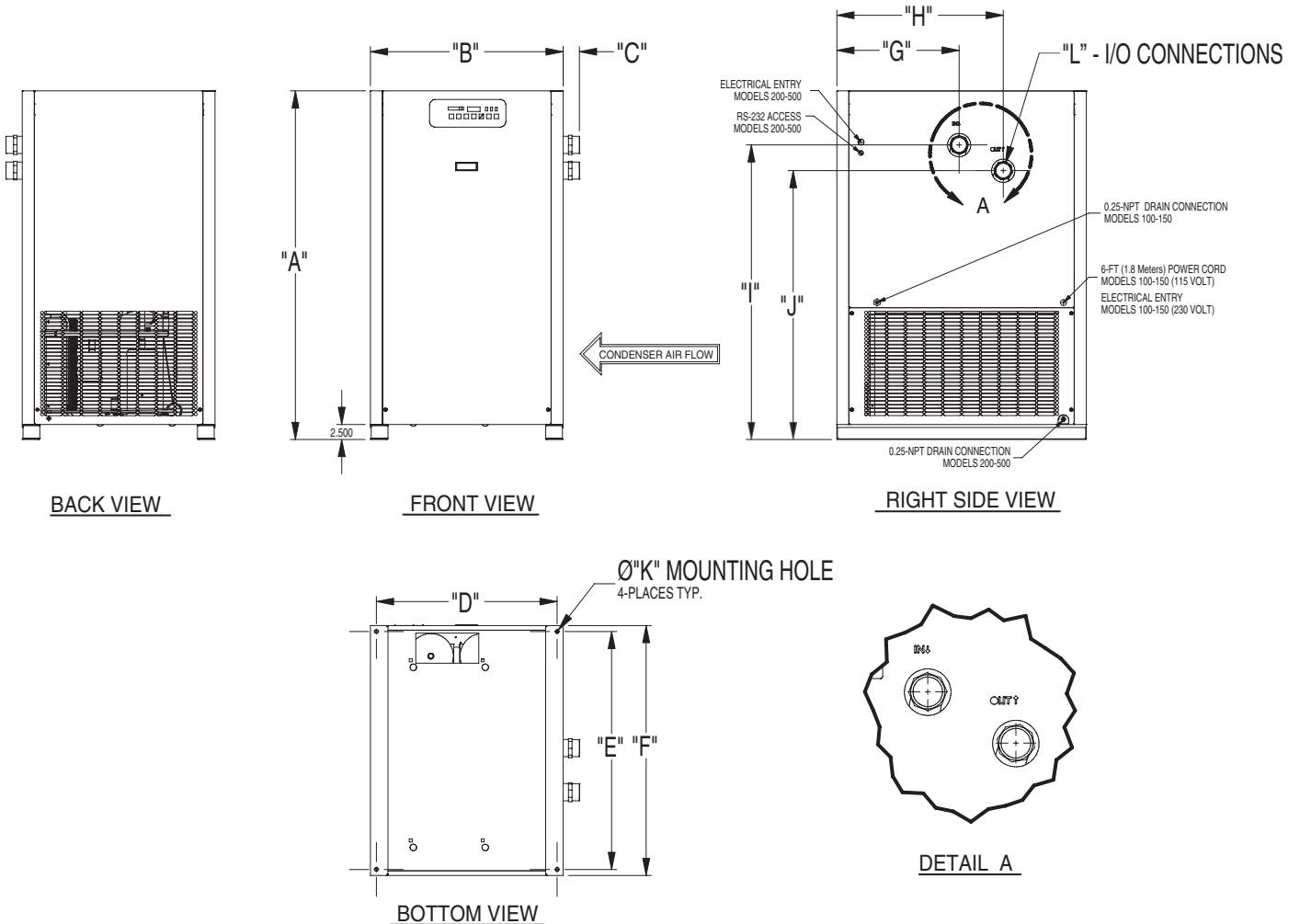

## TROUBLESHOOTING GUIDE (MODELS 100-150)

SYMPTOM	POSSIBLE CAUSE(S)	CORRECTIVE ACTION
<b>A) Water downstream of dryer</b>	<ol style="list-style-type: none"> <li>1. Residual free moisture remaining in downstream pipelines</li> <li>2. Air bypass system is open</li> <li>3. Inlet and Outlet connections are reversed</li> <li>4. Air lines downstream of dryer are exposed to temperatures below the dew point.</li> <li>5. Excessive free moisture (bulk liquid) at dryer inlet.</li> <li>6. Condensate not being drained Drain mechanism is clogged or inoperative. Drain line is restricted or frozen. Electric drains-timer not set to allow for sufficient condensate removal.</li> <li>7. Dryer overloaded resulting in elevated dew point.</li> <li>8. Refrigeration system not functioning</li> </ol>	<p>Blow out system with dry air</p> <p>Check valve positions Check for correct connection Insulate or heat trace air lines exposed to low ambients or dry air to lower dew point Install separator ahead of dryer</p> <p>Replace drain mechanism if inoperative.</p> <p>Open drain line. Electric drains-reset time so that all liquid is discharged Check inlet air temperature and pressure, flow rate (compressor capacity) and ambient air or water temperature. See D below</p>
<b>B) High pressure drop across dryer</b>	<ol style="list-style-type: none"> <li>1. Excessive air flow</li> <li>2. Freezing of moisture in evaporator because of refrigeration system fault</li> <li>3. Separator filter element clogged</li> </ol>	<p>Check flow rate See D below</p> <p>Replace filter element</p>
<b>C) Dew point indicator in red area</b>	<ol style="list-style-type: none"> <li>1. Dryer overloaded resulting in high air outlet temperature</li> <li>2. Refrigeration system not functioning properly resulting in high air outlet temperature</li> </ol>	<p>See A 7</p> <p>See D below</p>
<b>D) Refrigeration system not functioning properly</b> <ol style="list-style-type: none"> <li>1. Power on light off</li> <li>2. Refrigeration compressor cycles on and off</li> </ol>	<ol style="list-style-type: none"> <li>a. Power failure</li> <li>b. Line disconnect switch open</li> <li>c. Blown fuses, open breaker</li> <li>d. Faulty wiring, loose terminals</li> </ol> <ol style="list-style-type: none"> <li>a. High or low ambient conditions</li> <li>b. Air-cooled - Dirty, clogged condenser fins, obstructed flow across condenser, faulty fan motor or fan control switch.</li> </ol>	<p>Check for power to unit Close disconnect switch Check for continuity Have electrician check electrical connections.</p> <p>Check min./max. temperature ranges</p> <p>Clean condenser and check for free air flow, if problem persists contact qualified refrigeration repairman or manufacturer's service department.</p>



## TROUBLESHOOTING GUIDE (MODELS 200-500)

SYMPTOM	POSSIBLE CAUSE(S)	CORRECTIVE ACTION
<b>A) Water downstream of dryer</b>	<ol style="list-style-type: none"> <li>1. Residual free moisture remaining in downstream pipelines</li> <li>2. Air bypass system is open</li> <li>3. Inlet and Outlet connections are reversed</li> <li>4. Air lines downstream of dryer are exposed to temperatures below the dew point.</li> <li>5. Excessive free moisture (bulk liquid) at dryer inlet.</li> <li>6. Condensate not being drained</li> <li>7. Dryer overloaded resulting in elevated dew point.</li> <li>8. Refrigeration system not functioning</li> </ol>	<ol style="list-style-type: none"> <li>1. Blow out system with dry air</li> <li>2. Check valve positions</li> <li>3. Check for correct connection</li> <li>4. Insulate or heat trace air lines exposed to low ambients or dry air to lower dew point</li> <li>5. Install separator ahead of dryer</li> <li>6. See C below</li> <li>7. See C below</li> <li>8. See C below</li> </ol>
<b>B) High pressure drop across dryer</b>	<ol style="list-style-type: none"> <li>1. Excessive air flow</li> <li>2. Freezing of moisture in evaporator because of refrigeration system fault</li> <li>3. Filter loaded with solid particulates</li> </ol>	<ol style="list-style-type: none"> <li>1. Check flow rate</li> <li>2. See C below</li> <li>3. Replace filter element</li> </ol>
<b>C) Checkpoint faults</b> <ol style="list-style-type: none"> <li>1. Power on light off</li> <li>2. Compressor on light off</li>   <li>3. Alarm/Service alert light on               <ul style="list-style-type: none"> <li>-check Display for active conditions</li> <li>SERVICE DRYER</li> <li>LOW PRESSURE</li> <li>HIGH PRESSURE</li> <li>NOTE: If high refrigerant pressure occurs, switch must be manually reset</li> <li>HIGH TEMPERATURE (also observed as high reading on temperature indicator)</li> <li>DRAIN</li> <li>COMPRESSOR</li> <li>HEATER</li> <li>TEMP SENSOR</li> </ul> </li> </ol>	<ol style="list-style-type: none"> <li>a. Power failure; open circuit</li> <li>a. Compressor commanded off by manual switch or programmed schedule</li> <li>b. Open circuit</li> <li>c. Control circuit open on high or low pressure cutout</li>   <li>a. Service interval specified has elapsed</li> <li>a. Hot gas bypass valve requires adjustment</li> <li>b. Low on refrigerant</li>   <li>a. Lack of condenser cooling               <ul style="list-style-type: none"> <li>Air-cooled - Ambient temperature too high, clogged condenser fins, obstructed flow across condenser, faulty fan motor or fan control switch.</li> <li>Water-cooled - Cooling temperature too high, flow too low, clogged strainer, faulty water regulating valve</li> </ul> </li> <li>a. Dryer overloaded</li> <li>b. Refrigeration system off or not cooling sufficiently</li>   <li>a. Drain line restricted or frozen</li> <li>b. Drain mechanism faulty</li>   <li>a. Faulty compressor contactor.</li> <li>b. Faulty N.O. auxiliary contact on compressor contactor.</li>   <li>a. Faulty compressor contactor.</li> <li>b. Faulty N.C. auxiliary contact on compressor contactor.</li>   <li>a. Temperature sensor or wiring to sensor is open (only the left-most LED in the temperature display will be illuminated).</li> <li>b. Temperature sensor or wiring to sensor is shorted (all of the LEDs in the temperature display will be illuminated).</li> </ol>	<ol style="list-style-type: none"> <li>a. Check for power to dryer</li> <li>a. Check current command status</li>   <li>b. Check power to compressor</li> <li>c. Check display for fault</li>   <li>a. Perform scheduled service</li> <li>a. Contact qualified technician or manufacturer's service department</li>   <li>Check air temperature 6" in front of condenser; Clean condenser and check for free air flow; Check fan and switch operation</li> <li>Check cooling medium temperature and flow, clean strainer, check valve operation</li>   <li>a. Check compressed air flow, temperature, and pressure</li> <li>b. Check power to unit, power to compressor, Low or High pressure faults</li> <li>Have qualified technician evaluate system</li>   <li>a. Open drain line</li> <li>b. Turn 3-way valve to horizontal position and open petcock for manual draining. Rebuild drain mechanism.</li>   <li>a. Check wiring and operation of contactor.</li> <li>b. Check wiring and operation of auxiliary contact.</li>   <li>a. Check wiring and operation of contactor.</li> <li>b. Check wiring and operation of auxiliary contact.</li>   <li>a. Replace sensor or repair wiring.</li> <li>b. Replace sensor or repair wiring.</li> </ol>

NOTE: After fault correction, press reset button to clear display

# PARTS LIST

PARTS DESCRIPTION	100			125			150		
	115/1/60 100/1/60	208-230/1/60	220-240/1/50	115/1/60 100/1/60	208-230/1/60	220-240/1/50	115/1/60 100/1/60	208-230/1/60	220-240/1/50
Condensing Unit Assembly	5002001	5002002	5002003	7427771	7427772	7427773	7427771	7427772	7427773
Compressor (Only)	5002243	5002250	5002256	7427777	7427778	7427779	7427777	7427778	7427779
Overload	5002244	5002251	5002257	3233219	3233220	3252935	3233219	3233220	3252935
Start Relay	5002245	5002252	5002258	7427780	7427781	7427782	7427780	7427781	7427782
Start Capacitor	5002246	5002253	5002253	7427783	7427784	7427784	7427783	7427784	7427784
Run Capacitor	N/A	N/A	N/A	7427785	7427786	7427787	7427785	7427786	7427787
Fan Motor	5002247	5002254	5002259	3233151	3210368	3210368	3233151	3210368	3210368
Fan Blade	5002248	5002255	5002255	3219405	3219405	3219405	3219405	3219405	3219405
Hot Gas Bypass Valve	5002350	5002350	5002350	5002350	5002350	5002350	5002350	5002350	5002350
Condenser	5002249	5002249	5002249	3232828	3232828	3232828	3232828	3232828	3232828
Dryer	3223808	3223808	3223808	3223809	3223809	3223809	3223809	3223809	3223809
Fan Pressure Switch	3230761	3230761	3230761	3230761	3230761	3230761	3230761	3230761	3230761
Contact	N/A	N/A	N/A	5002260	5002262	5002262	5002260	5002262	5002262
Auxiliary Contactor	N/A	N/A	N/A	5002261	5002263	5002263	5002261	5002263	5002263
Crankcase Heater	N/A	N/A	N/A	3223258	3223259	3223259	3223258	3223259	3223259
Light Assembly (Green)	N/A	N/A	N/A	3227421	3215356	3215356	3227421	3215356	3215356
Dew Point Indicator	3224008	3224008	3224008	3224008	3224008	3224008	3224008	3224008	3224008
On-Off Switch	3230777	3230777	3230777	3230777	3230777	3230777	3230777	3230777	3230777
Temperature Sensor	3210926	3210926	3210926	3210926	3210926	3210926	3210926	3210926	3210926
Digital PC Board Fuse	5002943	5002943	5002943	5002943	5002943	5002943	5002943	5002943	5002943

PARTS DESCRIPTION	208-230/3/60			380-420/3/50, 460/3/60, and 575/3/60		
	200	250, 300, 400	500	200	250, 300, 400	500
Condensing Unit Assembly	5002007	5002009	5002011	5002008	5002010	5002012
Compressor (Only)	3221303	3232809	3221304	3210937	3211540	3210939
Fan Motor	3238932	3233153	3233153	3233152	3228005	3228005
Fan Blade	3232640	3232642	3219406	3232640	3232642	3219406
Crankcase Heater	3232974	3232974	3232974	3232975	3232975	3232975
Condenser	3232829	3232830	3232831	3232829	3232830	3232831
Low Refrigerant Pressure Switch	4006372	4006372	4006372	4006372	4006372	4006372
High Refrigerant Pressure Switch	3230764	3230764	3230764	3230764	3230764	3230764
Fan Cutout Switch 1	3230762	3230762	3230762	3230762	3230762	3230762
Fan Cutout Switch 2	N/A	N/A	3230763	N/A	N/A	3230763
Hot Gas By-Pass Valve (Air-Cooled)	5002350	5002350	5002350	5002350	5002350	5002350
Filter Dryer (Liquid Line)	5002925	5002925	5002925	5002925	5002925	5002925
Temperature Sensor	3210926	3210926	3210926	3210926	3210926	3210926
Contact	5002926	5002926	5002926	5002926	5002926	5002926
Auxiliary Contactor	5002927	5002927	5002927	5002927	5002927	5002927
Transformer 230/400/460	3159128	3159128	3159128	3159128	3159128	3159128
Fuse Primary	3223962	3223962	3223962	3223953	3223953	3223953
Fuse Secondary	4010495	4010495	4010495	4010495	4010495	4010495
Board, Printed Circuit (EMMII)	3227156	3227156	3227156	3227156	3227156	3227156
Digital PC Board Fuse	5002943	5002943	5002943	5002943	5002943	5002943
Power Transformer (575V)	3073856	3073856	3073856	3073856	3073856	3073856
Refrigerant High Pressure Switch (H2O)	3230764	3230764	3230764	3230764	3230764	3230764
On-Off Switch	3230777	3230777	3230777	3230777	3230777	3230777
Cooling Water Regulatory Valve	3232502	3232502	3232502	3232502	3232502	3232502
Cooling Water Strainer Screen	3230672	3230672	3230672	3230672	3230672	3230672

## Maintenance Kits

MODEL	100	125	150	200	250	300	400	500
Standard	KRDKT20S	KRDKT21S	KRDKT21S	KRDKT22S	KRDKT22S	KRDKT23S	KRDKT24S	KRDKT24S
With Optional Cold Coalescer	KRDKT40S	KRDKT41S	KRDKT41S	KRDKT42S	KRDKT42S	KRDKT43S	KRDKT44S	KRDKT44S



# WARRANTY

The manufacturer warrants the product manufactured by it, when properly installed, operated, applied, and maintained in accordance with procedures and recommendations outlined in manufacturer's instruction manuals, to be free from defects in material or workmanship for a period as specified below, provided such defect is discovered and brought to the manufacturer's attention within the aforesaid warranty period.

The manufacturer will repair or replace any product or part determined to be defective by the manufacturer within the warranty period, provided such defect occurred in normal service and not as a result of misuse, abuse, neglect or accident. Normal maintenance items requiring routine replacement are not warranted. The warranty covers parts and labor for the warranty period unless otherwise specified. Repair or replacement shall be made at the factory or the installation site, at the sole option of the manufacturer. Any service performed on the product by anyone other than the manufacturer must first be authorized by the manufacturer.

Unauthorized service voids the warranty and any resulting charge or subsequent claim will not be paid. Products repaired or replaced under warranty shall be warranted for the unexpired portion of the warranty applying to the original product.

The foregoing is the exclusive remedy of any buyer of the manufacturer's product. The maximum damages liability of the manufacturer is the original purchase price of the product or part.

THE FOREGOING WARRANTY IS EXCLUSIVE AND IN LIEU OF ALL OTHER WARRANTIES, WHETHER WRITTEN, ORAL, OR STATUTORY, AND IS EXPRESSLY IN LIEU OF THE IMPLIED WARRANTY OF MERCHANTABILITY AND THE IMPLIED WARRANTY OF FITNESS FOR A PARTICULAR PURPOSE. THE MANUFACTURER SHALL NOT BE LIABLE FOR LOSS OR DAMAGE BY REASON OF STRICT LIABILITY IN TORT OR ITS NEGLIGENCE IN WHATEVER MANNER INCLUDING DESIGN, MANUFACTURE OR INSPECTION OF THE EQUIPMENT OR ITS FAILURE TO DISCOVER, REPORT, REPAIR, OR MODIFY LATENT DEFECTS INHERENT THEREIN.

THE MANUFACTURER, HIS REPRESENTATIVE OR DISTRIBUTOR SHALL NOT BE LIABLE FOR LOSS OF USE OF THE PRODUCT OR OTHER INCIDENTAL OR CONSEQUENTIAL COSTS, EXPENSES, OR DAMAGES INCURRED BY THE BUYER, WHETHER ARISING FROM BREACH OF WARRANTY, NEGLIGENCE OR STRICT LIABILITY IN TORT.

The manufacturer does not warrant any product, part, material, component, or accessory manufactured by others and sold or supplied in connection with the sale of manufacturer's products.

## Warranty Period

Parts and labor for two (2) years from the date of shipment from the factory; heat exchangers are covered (parts only) for an additional three (3) years (total of five (5)). On units that manufacturer requests be returned to the factory, a one time removal/reinstallation labor allowance as noted in the Service Warranty Policies and Procedures Handbook will apply. Freight to the factory from the installation site and to the installation site from the factory will be paid by the manufacturer; means of transportation to be specified by manufacturer.

**AUTHORIZATION FROM THE SERVICE DEPARTMENT IS NECESSARY BEFORE MATERIAL IS RETURNED TO THE FACTORY OR IN-WARRANTY REPAIRS ARE MADE.**

**SERVICE DEPARTMENT: (724) 745-3038**

**KAESER**

[www.kaeser.com](http://www.kaeser.com)

KAESER COMPRESSORS

**U.S.A.** • PO Box 946 • Fredericksburg, VA 22404 • Tel: 540/898-5500 • Fax: 540/898-5520 • Service: 724/745-3038

**Canada** • 3760 Rue La Verendrye • Boisbriand (Quebec) J7H 1R5 • Tel: 450/971-1414 • Fax: 450/971-1415 • Service: 450/971-1414