

SERVICE MANUAL

USE

Refrigerated Dryer

Model: TE 141

GL-Nr.: BA-TE141-1.8039.00010-00
Index: 000801

Serial No.:

Table of Contents

Chapter – Page

1	Technical Specification	1 – 1
1.1	Refrigerated Dryer	1 – 1
1.2	Compressed Air System	1 – 1
1.3	Refrigerant System	1 – 1
1.4	Installation Requirements	1 – 1
1.5	Connections	1 – 1
1.6	Electrical Connection	1 – 2
1.7	Settings	1 – 2
1.8	Identification	1 – 2
1.9	Dimensional Diagram	1 – 2
1.10	Bypass 2 NPT	1 – 4
2	Safety Regulations	2 – 5
2.1	Explanation of Symbols and References	2 – 5
2.2	General Safety Instructions	2 – 5
2.3	General References	2 – 6
2.4	Spare Parts	2 – 6
2.5	Environmental Protection	2 – 7
3	General	3 – 8
3.1	Proper use	3 – 8
3.2	Improper use	3 – 8
3.3	Copyright	3 – 8
4	Transport	4 – 9
4.1	Transport Instructions	4 – 9
4.2	Packaging	4 – 9
4.3	Temporary Storage	4 – 10
5	Construction and Operation	5 – 11
5.1	Construction	5 – 11
5.2	Functional Description	5 – 11
5.3	Refrigerant Circulation	5 – 11
5.4	ECO–DRAIN	5 – 12
5.4.1	Functional Principle	5 – 12
5.4.2	Indication of Operational Status	5 – 12
5.5	Component Identification	5 – 14
5.6	Pipe and Instrument Flow Chart (P & I Flow Chart)	5 – 14
6	Installation	6 – 17
6.1	Installation Requirements	6 – 17
6.2	Compressed Air Connection	6 – 17
6.3	Condensate Drain Connection	6 – 18
6.4	Electrical Connection	6 – 18
6.5	Voltless Contacts	6 – 19

Table of Contents



Chapter – Page

7	Preparation For Initial Start Up	7 – 20
7.1	Points to be Observed before Start Up	7 – 20
7.2	Points to be Observed before Switching On:	7 – 20
7.3	Ready for Operation	7 – 21
8	Operation	8 – 22
8.1	Instrument Panel	8 – 22
8.2	Starting the Refrigerated Dryer	8 – 23
8.3	Stopping the Refrigerated Dryer	8 – 24
8.4	Trouble shooting	8 – 25
8.4.1	Water in the compressed air system	8 – 25
8.4.2	High pressure losses via the refrigerated dryer	8 – 25
8.4.3	Pressure dew point too high	8 – 25
8.4.4	High compressed air losses	8 – 26
8.4.5	Red LED on the ECO–DRAIN housing flashes	8 – 26
8.4.6	The safety pressure switch shuts down the refrigerated dryer	8 – 26
9	Maintenance	9 – 27
9.1	Maintenance Instructions:	9 – 27
9.2	Regular Maintenance	9 – 27
9.2.1	General checks	9 – 27
9.2.2	Cleaning the condenser	9 – 28
9.2.3	Check the condensate outlet daily as follows:	9 – 28
9.2.4	Check ECO–DRAIN for proper operation monthly, as follows:	9 – 28
9.2.5	Cleaning the ECO–DRAIN	9 – 29
10	Spare Parts and After Sales Service	10 – 33
11	Appendix	11 – 34
11.1	Wiring Diagram	11 – 34
11.2	Maintenance Schedule	11 – 45

1 Technical Specification

1.1 Refrigerated Dryer

Model	TE 141
Condensate volume under nominal conditions*	143 oz/h
Weight	1455 lbs
Cooling air volume	2118 cfm
Noise level to CAGI–Pneurop	< 70 dB(A)
at 1 m distance (free sound field measurement)	

* See chapter 1.2 for nominal conditions.

Drawings:

P & I flow chart	FKTTE141ST–00031.00
(Pipework and instrument flow chart)	
Electrical diagram	STE–U0909.00
Dimensional drawing	T 9156.2
By-pass piping	203990.0

1.2 Compressed Air System

Flow volume	520 scfm
Pressure drop	2.32 psid
Pressure dewpoint	35 °F
at 100 °F air inlet, 100 psig and 100 °F ambient temperature.	
Maximum gauge working pressure	190 psig

1.3 Refrigerant System

Refrigerant	R 134a
Maximum quantity	4.6 lbs
Permissible gauge working pressure	260 psig

1.4 Installation Requirements

Max. elevation above sea level of installation	3000 ft.
(for all elevations above please contact authorized KAESER distributor)	
Min. ambient temperature	40 °F
Max. ambient temperature	110 °F
Maximum compressed air inlet temperature	130 °F

1.5 Connections

Compressed air outlet	2 NPT
Condensate drain connection (hose connection)	1/2
Service connection (Schrader valve)	7/16 UNF

Technical Specification

1.6 Electrical Connection

Main voltage	460 V ± 10 % 3-phase
Full load current, FLA	4.3 A
Frequency	60 Hz
Recommended main disconnect fuses (Dual element or time-delay)	8 A
Recommended power supply cable (Cu multi-stranded) cross-section	14 AWG

Attention!

Maximum dual element time-delay fuses are selected according to 1996 N.E.C. Article 240-6, 430-52 and Tables 430-148 & 150.

Select multi-strand copper core wire at 40°C ambient temperature according to 1996 N.E.C. 110-14(c), 220-3, 310-15, Table 310-16, 430-6, 430-22 and Tables 430-148 & 150.

1.7 Settings

Safety pressure switch (refrigerant)

switching point (fixed)

P_{OFF} 265 psi

Thermostat

regulates pressure dewpoint to approx. 35 °F

1.8 Identification

The nameplate of the refrigeration dryer is located on the front left below the control panel (see chapter 10 for an illustration of the nameplate).

1.9 Dimensional Diagram

(see next page)

Technical Specification

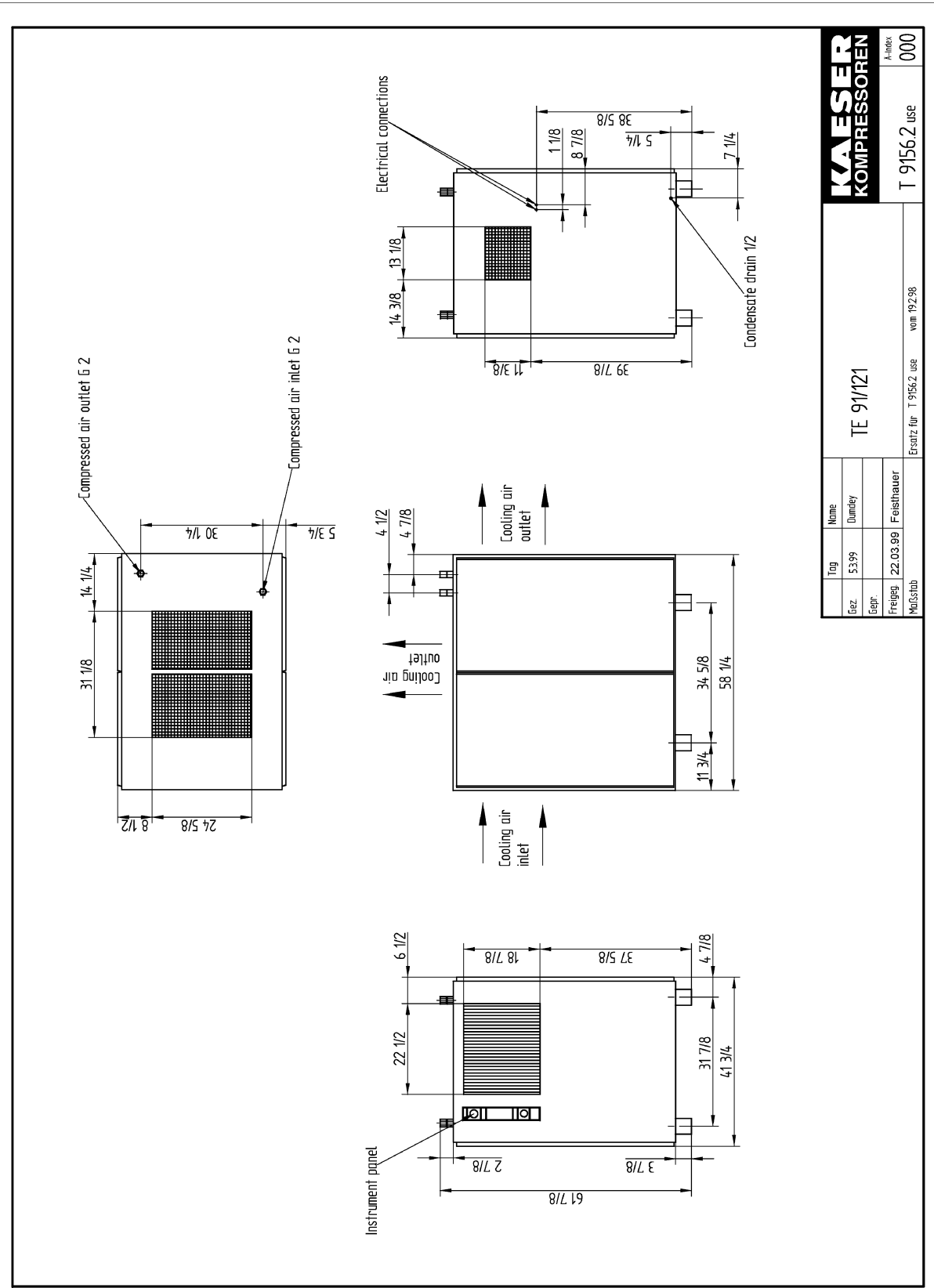

Diese Zeichnung ist unser Eigentum und darf gemaßs. Urheberrecht ohne unsere vorherige schriftliche Genehmigung nicht vervielfältigt oder Dritten zugänglich gemacht werden.
 Entwicklungsbedingte Änderungen vorbehalten. Zeichnung darf nur über CAD geändert werden.

1.10 Bypass 2 NPT

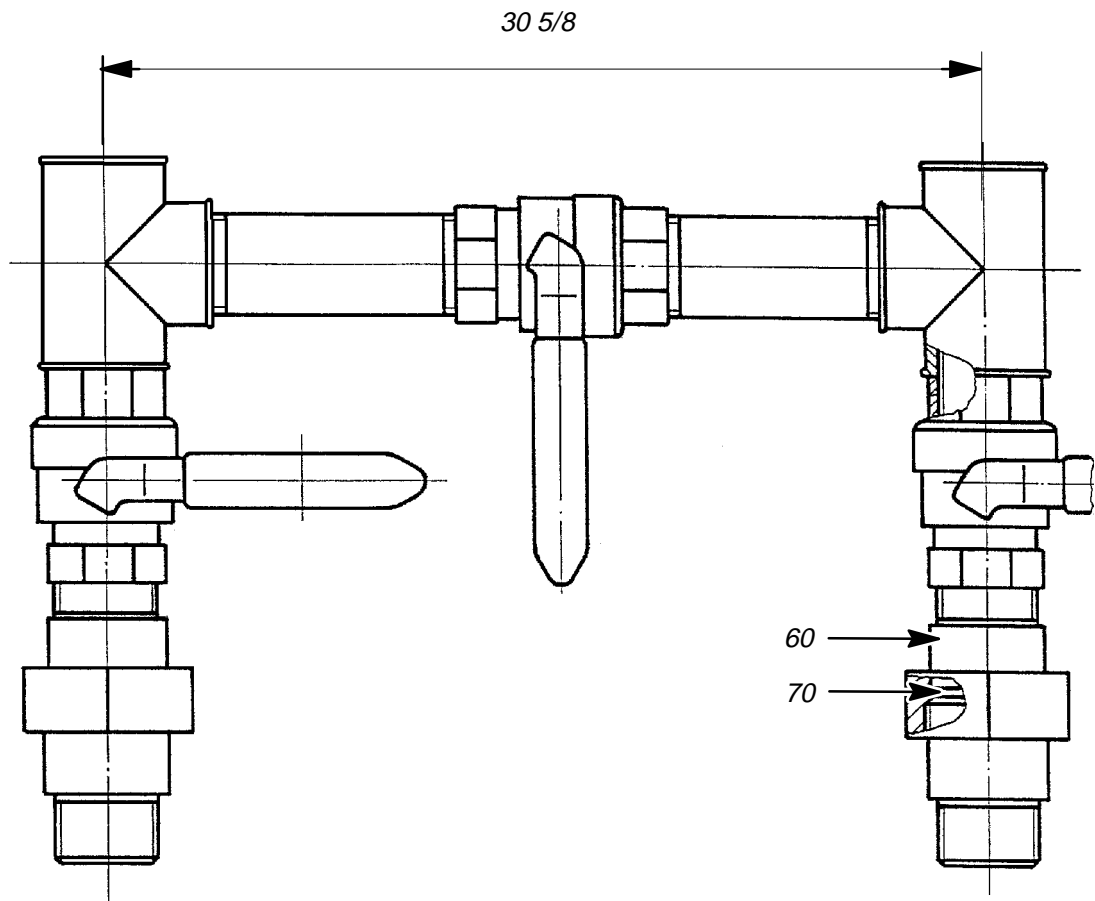

2 Safety Regulations

Read this service manual very carefully and observe all cautionary references before the initial start of this refrigerated dryer and before carrying out any maintenance on the unit.

2.1 Explanation of Symbols and References



This symbol is placed before all safety references where there is danger to life and limb. It is especially important that any associated instructions are followed explicitly and that extreme care is taken when performing the indicated task(s). For their own protection, inform all other users of these safety rules. Observe general safety and accident prevention regulations as well as the safety rules laid down in this service manual.

Attention!

This symbol is placed by text where considerable attention must be paid to recommendations, regulations, references and correct sequence so that damage and/or destruction of the compressor and/or other equipment is prevented.



This symbol identifies environmental care measures.



This symbol indicates operations to be carried out by the operator or service technician.

- This bullet identifies listings.

2.2 General Safety Instructions

Work on power driven systems may only be carried out by trained or instructed personnel or by specialized personnel.

Work on the electrical equipment of the refrigerated dryer may only be carried out by a qualified electrician or trained personnel under the supervision of a qualified electrician according to the NEC and any applicable local codes.

Work on the refrigeration system may only be carried out by a certified refrigeration technician (according to 40CFR Part 82).

2.3 General References



Work on power driven systems may only be carried out by trained or instructed personnel or by specialized personnel.

Work on the electrical equipment of the refrigerated dryer may only be carried out by a qualified electrician or trained personnel under the supervision of a qualified electrician according to the NEC and any applicable local codes.

Work on the refrigeration system may only be carried out by a certified refrigeration technician (according to 40CFR Part 82).

The refrigerated dryer contains activated electrical components. Carry out the following measures in the sequence shown before attempting any work on the electrical system:

1. Lock the main disconnect in the "off" position in accordance with applicable lock out/ tag out procedures (example: OSHA CFR 29 § 1910.147) to ensure the refrigerated dryer does not restart.
2. Ensure the unit cannot be switched on again
3. Check that no voltage is present
4. Lock the isolation shut-off valve in the "closed" position and vent all compressed air trapped in the refrigerated dryer or in the piping between the dryer and the isolation shut-off valve in accordance with applicable lock out/ tag out procedures (example: OSHA CFR 29 § 1910.147).

The refrigerated dryer contains systems subject to high pressures. Before any maintenance work is carried out, vent and shut off the pressure lines.



Escaping compressed air and/or refrigerant can cause injury to personnel and lead to damage to the dryer.



The refrigerant contained in the refrigerating system may not be vented to the open air. Always use a refrigerant recovery system when working on the refrigerant circulation. Dispose of unusable refrigerant according to environmental regulations!

Attention!

Any alterations or reconstruction carried out without the prior written authorization of KAESER COMPRESSORS Inc. will invalidate the warranty.

2.4 Spare Parts

The use of KAESER original parts guarantees safe and reliable operation of the refrigerated dryer.

2.5 Environmental Protection

Condensate drainage



The condensate accumulated during the drying of compressed air must be removed via a suitable drainage system, collected in special canisters and disposed of according to federal and local environmental regulations.

Maintenance materials/wear items/replacement parts



Ensure that all wear items, maintenance and replacement parts accumulated during operation of the refrigerated dryer are disposed of according to environmental regulations.

3 General



The service manual must always be available for use at the location of the refrigerated dryer.

3.1 Proper use

The refrigerated dryer is intended solely for drying compressed air.

Any other use outside of this purpose is considered improper. The manufacturer cannot accept liability for any damage caused by improper use; the user alone is liable for any risks incurred.

Proper use of the dryer includes compliance with the installation, removal, servicing, operation and maintenance instructions as specified by the manufacturer.

3.2 Improper use



Never direct compressed air toward persons. Compressed air is a concentrated form of energy and as such is dangerous to life.

3.3 Copyright

© KAESER COMPRESSORS, INC.

All rights reserved. No part of this manual may be reproduced in any form without permission of KAESER COMPRESSORS, INC.

Transport

4 Transport

4.1 Transport Instructions

Attention!

Under no circumstances lift the refrigerated dryer with the compressed air inlet and outlet connections or lay the refrigerated dryer on its side. Serious damage can result from such treatment of the refrigerated dryer.

To prevent damage to the panelling of the refrigerated dryer always use a jack lift or a forklift truck for transport.

- Always mount the refrigerated dryer on a suitable transporting medium (pallet or wooden base) during transport.

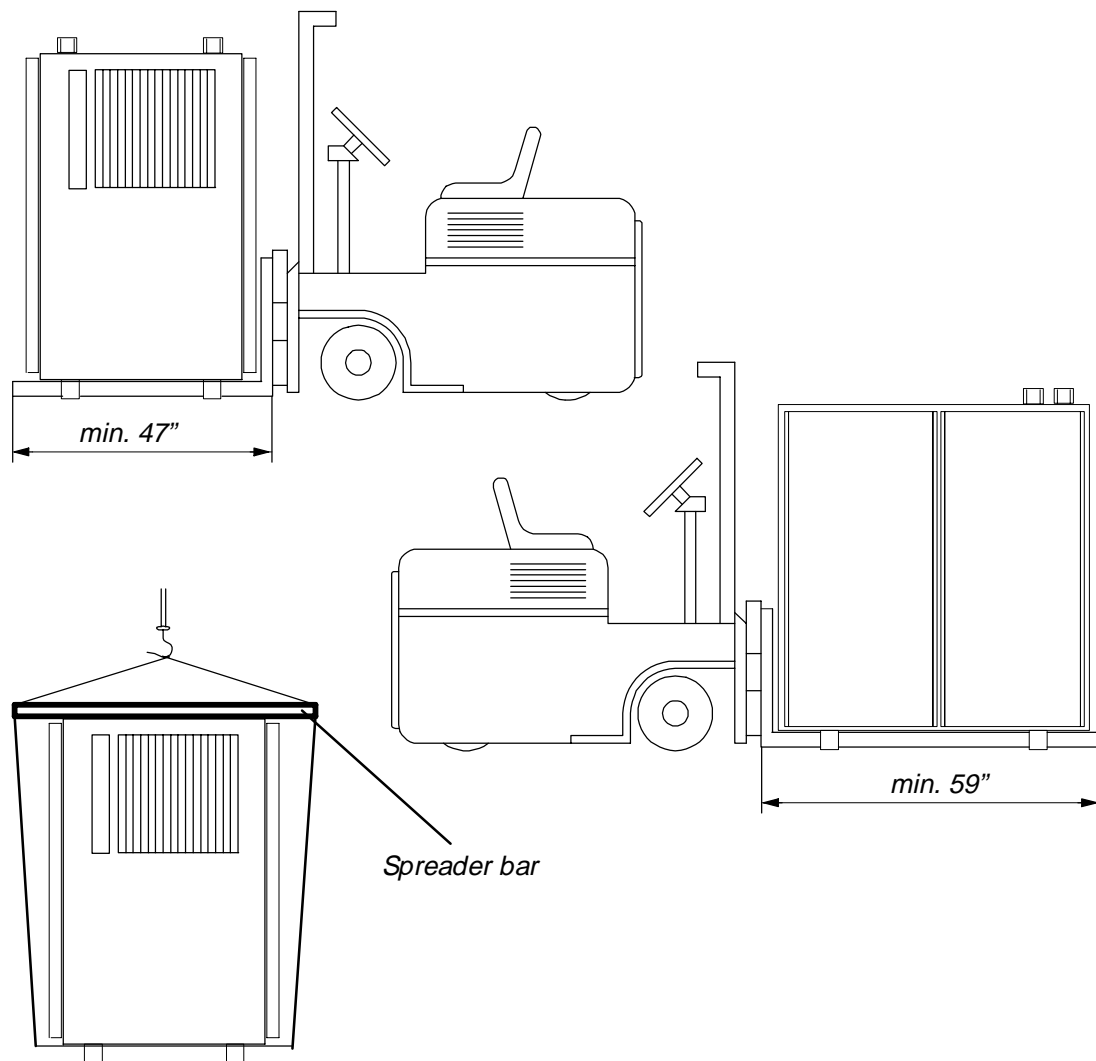
**Attention!**

Do not exert any side forces on the refrigerated dryer with lifting equipment.

4.2 Packaging

The packaging provided with this compressor as delivered is intended to safeguard the package against normal road transport damage. Please dispose of in an environmentally friendly way and arrange for it to be recycled if possible.

4.3 Temporary Storage

Store the refrigerated dryer in an enclosed space, regardless of whether it is packaged or not.

The storage temperature should not fall below -13°F and not rise above 140°F .

Attention!

Before initial start, wait until the temperature of the refrigerated dryer has adapted to the ambient temperature.

5 Construction and Operation

Numbers enclosed in parentheses () correspond with the numbered items in the Pipe and Instrument Flow Diagram (see chapter 5.6).

5.1 Construction

The main component of the refrigerated dryer comprises a combined heat exchanger. It consists of the two following stages:

1st. stage: air to air heat exchanger (1)

2nd. stage: air to refrigerant heat exchanger (2)

The refrigerant circulation is automatically regulated by a thermostat (13). A moisture separator and condensate drain (3) are located in series with the heat exchanger.

A safety pressure switch (9) is fitted in the refrigerant circulation system as a protection against excessive pressure.

A thermal overload switch protects the refrigerant compressor (11) against current overloads and high temperatures.

5.2 Functional Description

The cooling action of the refrigeration dryer causes the condensation and subsequent separation of the humid content of the compressed air.

The warm compressed air of high humidity entering the unit is initially cooled in the air to air heat exchanger (1) through heat exchange with the cooled compressed air leaving the unit. The moisture precipitated in the air to air heat exchanger is drained via an automatic condensate drain (5).

Further cooling occurs in the air to refrigerant heat exchanger (2), connected in series with the air to air heat exchanger through the action of expanding, gassing refrigerant. This action causes the humid components of the compressed air to condense out when the pressure dewpoint is undercut.

The condensate separator, (3) connected in series, separates the condensed water and oil droplets, together with coarse dirt particles, from the compressed air. This condensate is removed from the system by an automatic condensate drain (5).

The dried compressed air is then rewarmed by flowing through the air to air heat exchanger (1) before leaving the refrigeration dryer.

The refrigerant compressor (11) is switched off by a thermostat if the refrigeration demand sinks and switched on again when the demand rises. Considerable savings in energy are possible with this principle of operation.

5.3 Refrigerant Circulation

The dryer is able to cool the compressed air by using a refrigeration system not unlike a typical home refrigerator. Cooling is achieved by transferring heat from the compressed air to the refrigerant by vaporizing (boiling) the refrigerant, thereby turning the refrigerant into a gas. A more complete description of this process is given below:

The refrigerant enters the hermetically sealed compressor (11) as a low pressure gas. The gas is compressed to a suitable pressure to ensure that the gas is nearly saturated. The high pressure refrigerant gas flows to the condenser (10) where heat is removed from the refrigerant. As the high pressure refrigerant gas is cooled, the refrigerant becomes a liquid.

The high pressure liquid is then forced through a capillary tube (7). By forcing the refrigerant through this restriction, the refrigerant becomes a low pressure liquid. The low pres-

Construction and Operation

sure, liquid refrigerant enters the evaporator (2) where heat from the compressed air is transferred to the refrigerant. The added heat causes the refrigerant to boil and results in the refrigerant becoming a low pressure gas. This becomes an endless cycle which allows the refrigerant to simply remove heat from the compressed air and expel it to the ambient air.

5.4 ECO-DRAIN

5.4.1 Functional Principle

Items referred to in () refer to the items in the following figures.

- The accumulating condensate enters the collector tank (2) via the inlet openings (1). The diaphragm valve (4) is closed.
- A capacitive sensor (3) continuously registers the liquid level and passes a signal to the electronic control (7) as soon as the chamber is full. The pilot valve is activated and the diaphragm valve (4) opens the outlet line (5). When the ECO-DRAIN is empty, the outlet line is closed again before compressed air can escape.

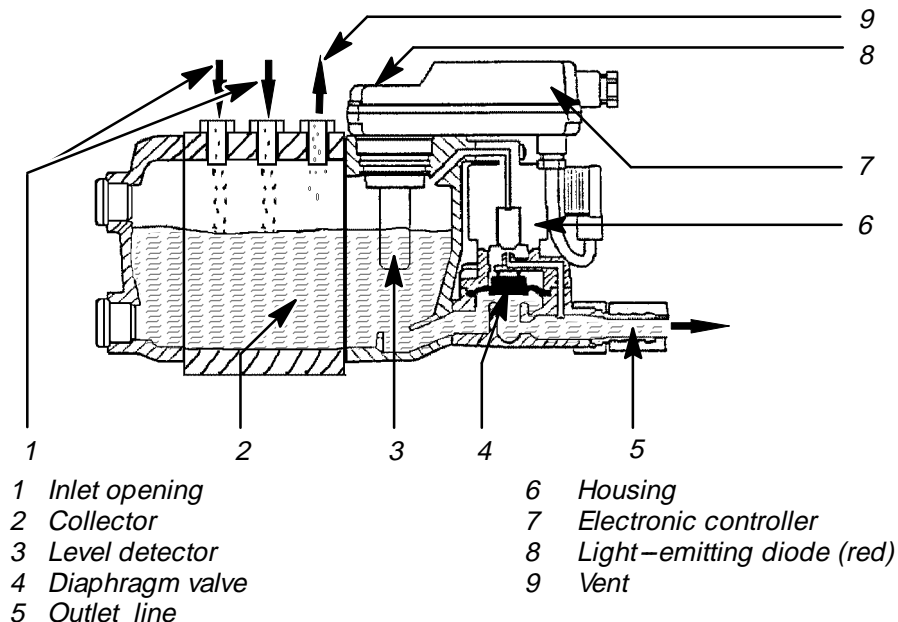

- If a fault occurs (e.g. overload), the valve cycles on and off continuously to clear the fault. The light-emitting diode flashes.

5.4.2 Indication of Operational Status

The operational status of the condensate drain is indicated by three light-emitting diodes on the housing of the ECO-DRAIN.

- 1 red light-emitting diode "Alarm" flashing continuously:
 fault, overload
 Alarm mode is activated.
- 2 yellow light-emitting diode "Valve" on:
 Discharge procedure
 Outlet pipe is open.
- 2 green light-emitting diode "Power ON":
 Normal ECO-DRAIN operation
 Voltage is being applied.

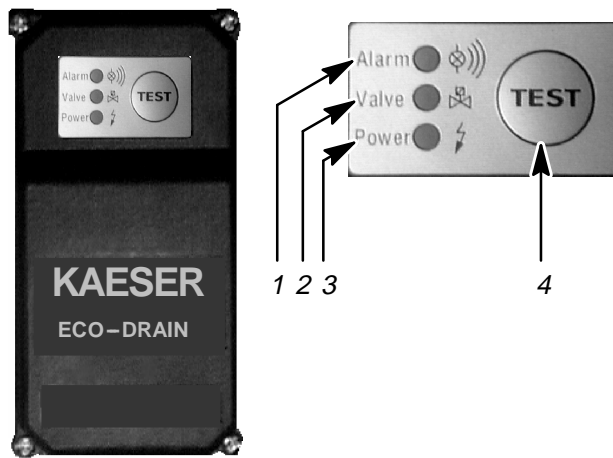

- 1 Light emitting diode "Alarm"
- 2 Light emitting diode "Valve"
- 3 Light emitting diode "Mains"

- 4 TEST-pushbutton (Condensate drain)

Construction and Operation

5.5 Component Identification

Numbers in () correspond to those in the Pipe and Instrument Flow Chart.
(P & I Flow Chart).

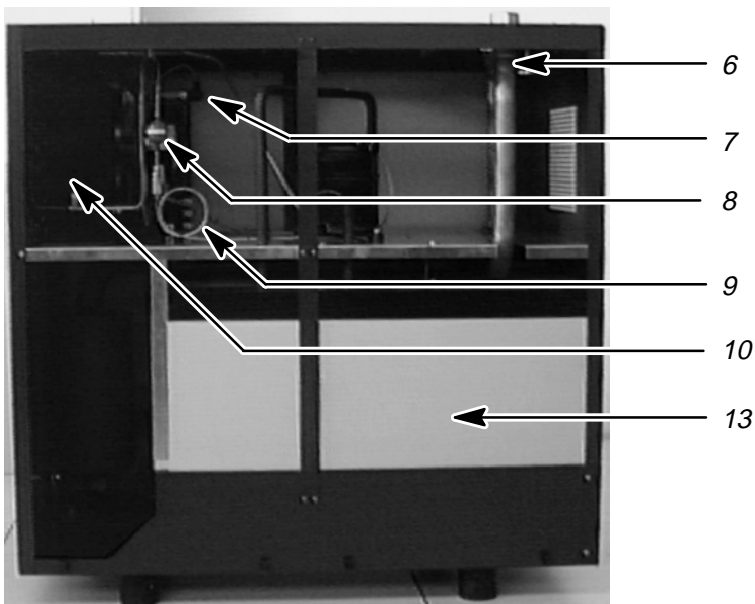
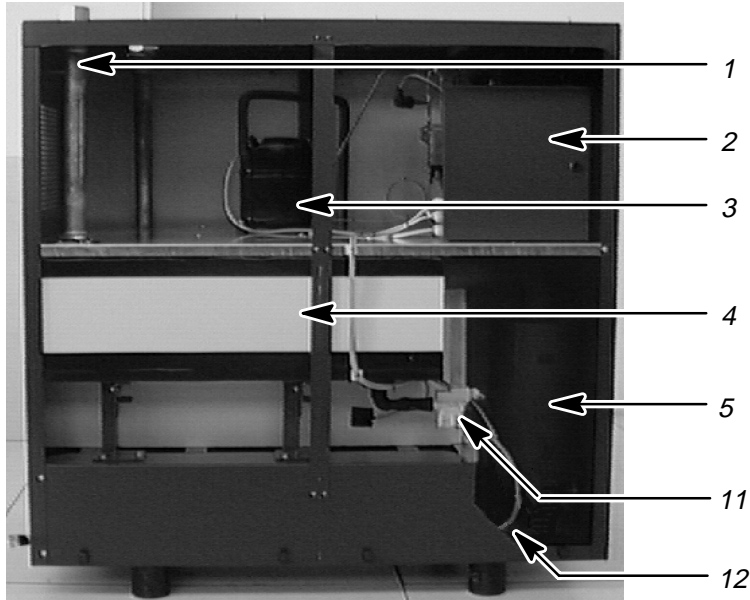

- | | |
|---------------------------------|--|
| 1 Compressed air outlet | 8 Filter dryer (8) |
| 2 Control cubicle | 9 Capillary tube (7) |
| 3 Refrigerant compressor (11) | 10 Refrigerant liquefier (10) |
| 4 Air to air heat exchanger (1) | 11 Condensate ECO-DRAIN (5) |
| 5 Condensate separator (3) | 12 Drain hose |
| 6 Compressed air inlet | 13 Air to refrigerant heat exchanger (2) |
| 7 Safety pressure switch (9) | |

5.6 Pipe and Instrument Flow Chart (P & I Flow Chart)

(see following pages)

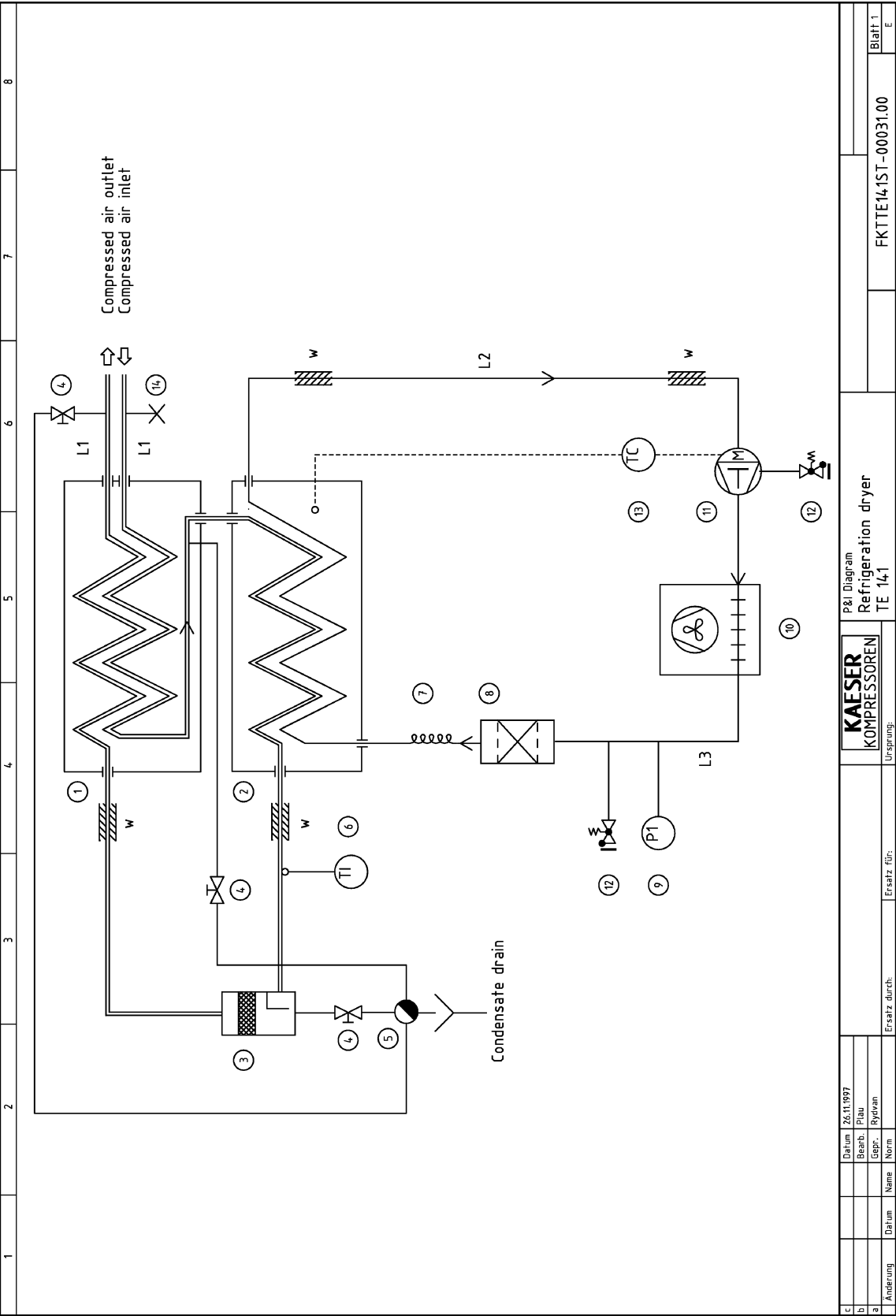

Date		26.11.1997	
Author		Plau	
Editor		Rydvan	
Norm			
Date			
Name			
Ersatz durch:			
Ersatz für:			
Origin:		KAESER KOMPRESSOREN	
P&I Diagram		Refrigeration dryer TE 14,1	
FKTTE141ST-00031.00		Blatt 1	
		E	

1	2	3	4	5	6	7	8																									
1	Air/air heat exchanger				} heat insulated																											
2	Air to refrigerant heat exchanger (Evaporator)																															
3	Condensate separator																															
4	Shut-off valve																															
5	Condensate drain																															
6	Pressure dew point indicator TI																															
7	Capillary tube (Refrigerant injection)																															
8	Filter dryer																															
9	Safety pressure switch																															
10	Refrigerant condenser (air cooled condenser)																															
11	Refrigerant compressor (hermetic)																															
12	Service connection (Schrader valve)																															
13	Thermostat																															
14	Connection for hose coupling R 1/4																															
Piping:																																
L1	CU-Pipe 54 x 2,0 DIN 1708																															
L2	CU-Pipe 12 x 1,0 DIN 1708																															
L3	CU-Pipe 8 x 1,0 DIN 1708																															
w	heat insulated																															
<table border="1"> <tr> <td>c</td> <td>Datum</td> <td>26.11.1997</td> </tr> <tr> <td>b</td> <td>Bearb.</td> <td>Plau</td> </tr> <tr> <td>a</td> <td>Gepr.</td> <td>Rydvan</td> </tr> </table>		c	Datum	26.11.1997	b	Bearb.	Plau	a	Gepr.	Rydvan	<table border="1"> <tr> <td colspan="2">Ersatz durch:</td> <td colspan="2">Ersatz für:</td> </tr> <tr> <td colspan="2"></td> <td colspan="2">Ursprung:</td> </tr> </table>		Ersatz durch:		Ersatz für:				Ursprung:		<table border="1"> <tr> <td colspan="2"> KAESER KOMPRESSOREN </td> <td colspan="2"> P+I Diagram legend Refrigeration dryer TE 14,1 </td> </tr> </table>		KAESER KOMPRESSOREN		P+I Diagram legend Refrigeration dryer TE 14,1		<table border="1"> <tr> <td colspan="2">FKTTE14IST-00031.00</td> </tr> <tr> <td>Blatt 2</td> <td>E</td> </tr> </table>		FKTTE14IST-00031.00		Blatt 2	E
c	Datum	26.11.1997																														
b	Bearb.	Plau																														
a	Gepr.	Rydvan																														
Ersatz durch:		Ersatz für:																														
		Ursprung:																														
KAESER KOMPRESSOREN		P+I Diagram legend Refrigeration dryer TE 14,1																														
FKTTE14IST-00031.00																																
Blatt 2	E																															

Installation

6 Installation

6.1 Installation Requirements

The refrigerated dryer must be installed in a dry and dust free space. To ensure adequate room for the maintenance of the refrigerated dryer, the minimum distances must be complied with (see following sketch).

Install the dryer on an even flat surface. Special foundations for the installation of the refrigerated dryer are not necessary.

See chapter 1.4 for the the ambient temperature and maximum height of the place of installation.

Attention!

To ensure adequate ventilation and air circulation, be sure to allow for the indicated minimum clearances at the cooling air inlet and exhaust.

The refrigerated dryer must not be installed in the air inlet and/or cooling air outlet area of a compressor package.
The compressed air to be dried and the ambient air in the compressor space may not contain any acid-forming or other aggressive materials.

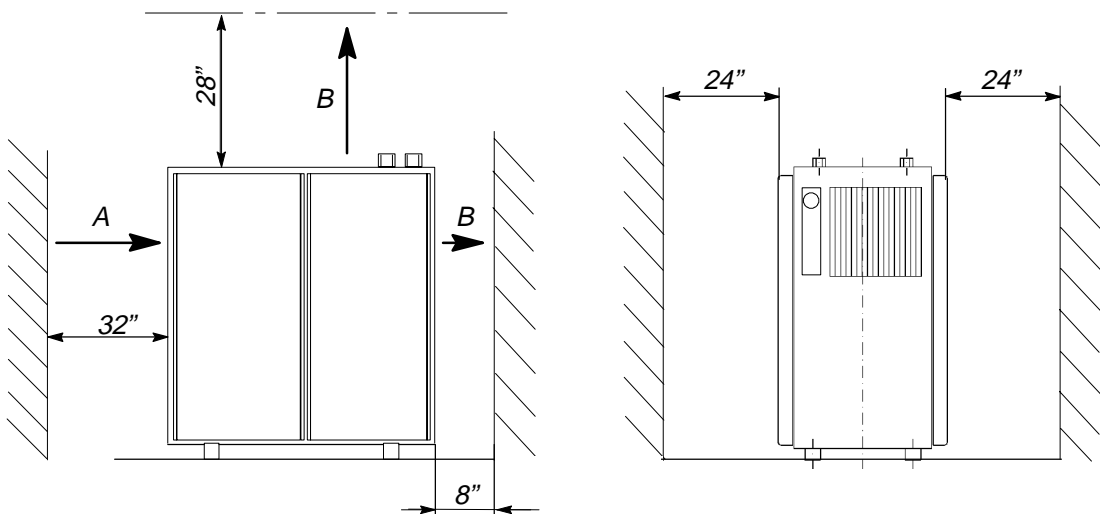

Measurements shown are minimum recommendations

A Cooling air inlet

B Cooling air outlet

Attention!

Installing of inlet and/or exhaust air ducting without prior written approval from of KAESER COMPRESSORS Inc. is not permitted.

6.2 Compressed Air Connection

Attention!

Use flexible connecting pipes at the compressed air inlet and discharge to ensure vibration isolation, prevent strain on piping connections and allow easy installation.
To avoid damage, do not overtighten the compressed air connections.

Installation

The refrigeration dryer is piped ready for operation.

Shut-off valves:



All power driven systems must be equipped with a main stop system for all forms of energy feed, the operation of which determines the start and stop of the energy supply to the system.

The compressed air inlet and outlet pipework must be provided with shut off arrangements (e.g. ball valves).

Bypass:

The compressed air inlet and outlet should be fitted with a bypass.

See diagram in chapter 1.10 for details of the bypass.

Installation notes:

Identification numbers in () correspond to the diagram of the bypass in chapter 1.10.

- ☞ Screw the threaded part of the union fitting (60) (with sealing tape) into the corresponding connection for the compressed air inlet or outlet.
- ☞ Insert the flat gasket (70) and fit the bypass by screwing down and tightening the union nut of the fitting (60).
- ☞ Check the fittings for leakages.

See chapter 1.5 for the dimensions of the connector fittings.

6.3 Condensate Drain Connection

A hose connection is provided for drainage of the condensate. See chapter 1.5 for the dimensions.

Attention!

Use caution when attaching the condensation drain line to ensure that the condensate flow is not obstructed.



The condensate must be drained and collected in a suitable container. It must be disposed of in accordance with federal and local environmental codes.

6.4 Electrical Connection



The main power supply and overcurrent protection must be installed by a qualified electrician in accordance with NEC, OSHA and any applicable local codes.

For fuse and wire recommendations, see chapter 1.6.

The refrigerated dryer is delivered completely wired, ready for connection to the power supply. This connection must be made as detailed in the electrical diagram (see chapter 11.1). See the dimensional diagram (see chapter 1.9) for the position and size of the cable entry into the refrigerated dryer.

Attention!

Maximum dual element time-delay fuses are selected according to 1996 N.E.C. Article 240-6, 430-52 and Tables 430-148 & 150.

Select multi-strand copper core wire at 40°C ambient temperature

according to 1996 N.E.C. 110–14(c), 220–3, 310–15, Table 310–16, 430–6, 430–22 and Tables 430–148 & 150.

Wire temperature rating:

1.25 x FLA (see chapter 1.6)	wire temperature rating	correction factor for 40 °C
≤ 100A	60 °C	0.82
> 100A	75 °C	0.88

6.5 Voltless Contacts

The refrigerated dryer is provided with the following volt-free alarm contacts for connection to an external alarm reporting system:

- Message: "Motor running"
- Message: "High pressure dewpoint "

Preparation For Initial Start Up

7 Preparation For Initial Start Up

7.1 Points to be Observed before Start Up

Every refrigerated dryer is tested in the factory and carefully checked before shipment. The test run confirms that the refrigerated dryer conforms to the manufacturer's specifications and operates as designed. However, independent of the checks made at the factory, the refrigerated dryer could be damaged during transport. For this reason, we recommend that the refrigerated dryer be examined for any damage. Inspect the refrigerated dryer carefully during the first hours of operation for any possible malfunction.

Attention!

The internal components of the refrigerated dryer are factory adjusted for correct operation. Adjustments may not be made to these components without prior written consultation with KAESER Compressors Inc.

7.2 Points to be Observed before Switching On:



NON-OBSERVANCE OF THESE OR OTHER REFERENCES (WARNING; ATTENTION) CAN LEAD TO ACCIDENTS CAUSING INJURY TO PERSONNEL OR DAMAGE TO EQUIPMENT.

It is forbidden to operate the refrigeration dryer with the panelling removed because of the danger of injury to personnel.

- ☞ Remove all packaging materials, tools and transport securing devices on and in the refrigerated dryer.
- It is expected that the user employs safe working techniques when operating the refrigeration dryer and that all valid operating and safety provisions are followed.
- The operator of this refrigerated dryer unit is responsible for its safe working condition.
- The air in the compressor space and the compressed air to be dried may not contain any acid-forming or other aggressive matter.
- Do not connect the refrigerated dryer to a supply voltage different to that shown on the nameplate.
- Install the refrigerated dryer in a space that is not subject to freezing conditions. See chapter 1.4 for the minimum ambient temperature.
- Wait for the refrigerated dryer to warm up to the ambient temperature before putting into operation.



Carry out the following work only when the power supply is removed from the refrigerated dryer:

Check all screws on the electrical connections for tightness and tighten if necessary (carry out this check again after 50 operating hours).

7.3 Ready for Operation

Attention!

Do not start the refrigerated dryer until completing the following:

- The refrigerated dryer is installed according to the conditions stated in chapter 6.
- All electrical connections, air piping and condensate lines are correctly connected and properly tightened.
- The shut-off valves in the compressed air inlet and outlet lines are closed.
- The condensate drainage line is free of obstructions.
- The refrigerated dryer is supplied with the correct voltage supply.
- The by-pass in the compressed air line between input and output lines is closed.

Attention!

Start the refrigerated dryer for approximately 15 minutes before opening the shut-off valves in the compressed air inlet and outlet lines.

Operation

8 Operation

During operation of the refrigerated dryer, condensate is separated from the compressed air.



The condensate must be drained and collected in a suitable container. It must be disposed of according to Federal and local environmental codes.

☞ Collect the accumulated condensate in a container and dispose of properly.

8.1 Instrument Panel

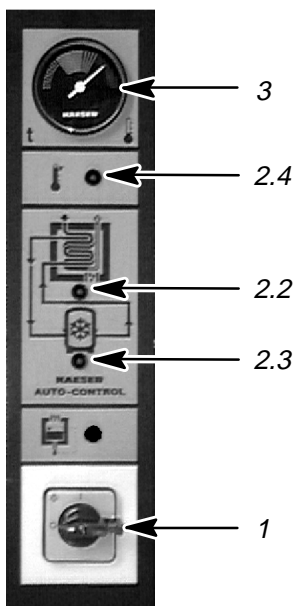

- 1 Main switch
- 2 KAESER-AUTO-CONTROL:
 - 2.2 "Control Voltage ON" and thermal mass effective
 - 2.3 "Refrigerant Compressor ON" indication
 - 2.4 "High Dewpoint" alarm
- 3 Pressure dewpoint gauge

Operation

Explanation of the colored segment scale of the pressure dew point indication:
(suction pressure gauge)

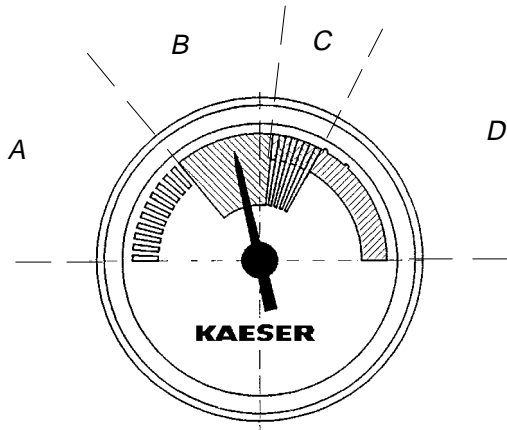

- **A**

Blue–white range (low suction pressure) results in too low a pressure dewpoint due to:

- Evaporator temperature too low (evaporator freeze–up)
- Dryer too large or very low air demand. Refer to chapter 1.4

- **B**

Green range (normal suction pressure) results in a normal pressure dew point.

- **C**

Green–red range (elevated suction pressure) results in increased pressure dew point to:

- High ambient temperature

- **D**

Red range (high suction pressure) results in too high a pressure dew point due to:

- Fault, see chapter 8.4.3 for help

8.2 Starting the Refrigerated Dryer

Attention!

Switch on the refrigerated dryer only if the conditions in chapter 7.3 “Ready for Operation” are fulfilled.

- ☞ Check the refrigerated dryer according to chapter 7.3.
- ☞ Remove the padlock provided for protection against “inadvertent switch–on” of switch (1).
- ☞ Rotate the switch (1) to “I” (ON).

The refrigeration dryer is now in operation, the control lamp (2.2) illuminates indicating power on.

Depending on the temperature in the air to refrigerant heat exchanger, the refrigerant compressor switches on after the refrigeration dryer is switched on. Simultaneously the control lamp (2.3) “Refrigerant Compressor ON” illuminates.

Operation



If the control lamp (2.3) does not extinguish after approximately 15 minutes then a fault is apparent (see chapter 8.4.3).

Attention!

Do not open the compressed air shut-off devices (inlet/outlet) until the control lamp (2.3) is extinguished.

- ☞ Open the shut-off valve of the compressed air inlet slowly (admission of the compressed air).
- ☞ Open the shut-off valve of the compressed air outlet slowly.

The compressed air system is now connected to the refrigerated dryer.

Attention!

Press RESET if the safety pressure switch has shut down the refrigerated dryer.



1 RESET

8.3 Stopping the Refrigerated Dryer

- ☞ Close the compressed air shut-off valves (inlet and outlet).

Attention!

The main switch (1) can be secured in the "0" position against inadvertent switch-on by a small padlock.

- ☞ Turn switch (1) to "0" (OFF).

The refrigerated dryer is switched off and the control lamp is off.

8.4 Trouble shooting



The local safety regulations (see chapter 2) and the regulations detailed in the "Safety" chapter must be complied with during trouble-shooting.

See chapter 7.3 and chapter 8.2. when starting the refrigerated dryer after the malfunction has been corrected.

8.4.1 Water in the compressed air system

Possible cause:

Moisture deposits in the compressed air pipe work that were formed before the dryer was started.

Bypass opened.

Compressed air inlet and outlet swapped.

The condensate is not drained out of the system.

Remedy:

Blow out the compressed air pipe work with dry air until no more moisture condenses.

Close the bypass.

Check the compressed air connections using the dimensional diagram.

Check the ECO-DRAIN (see chapter 9.2.4); Contact the authorized KAESER distributor.

8.4.2 High pressure losses via the refrigerated dryer

Possible cause:

Refrigerated dryer iced up on the air side.

Remedy:

Switch (1) to the "OFF" (0) position. until the air system has thawed. If the system ices up again after starting again, refer to authorized KAESER distributor.

8.4.3 Pressure dew point too high

Possible fault:

Ambient temperature too high.

Compressed air inlet temperature is too high.

Flow volume too high.

Low refrigerant.

Defective refrigerant compressor.

Defective condenser fan motor.

High contamination component in the compressed air causing scale in the compressed air system.

Condenser surface (refrigerant liquefier) contaminated.

Remedy:

Check the technical data, see chapter 1.2.

Check the technical data, see chapter 1.2.

Check the technical data, see chapter 1.2.

Refer to authorized KAESER distributor.

Refer to authorized KAESER distributor.

Refer to authorized KAESER distributor.

Clean the compressed air system.

See maintenance instructions chapter 9.2.2.

8.4.4 High compressed air losses

Possible fault:

Constant loss of pressure via the condensate drain.

Remedy:

Clean the ECO–DRAIN (see chapter 9.2.5).

8.4.5 Red LED on the ECO–DRAIN housing flashes

Possible cause:

Condensate not draining.

Remedy:

Check the ECO–DRAIN (see chapter 9.2.4); contact authorized KAESER distributor.

8.4.6 The safety pressure switch shuts down the refrigerated dryer

Possible fault:

Ambient temperature too high.

Remedy:

Check the technical data, see chapter 1.2.

Condenser surface (refrigerant liquefier) contaminated.

See maintenance instructions chapter 9.2.2.

Defective condenser fan motor.

Refer to authorized KAESER distributor.

Maintenance

9 Maintenance

9.1 Maintenance Instructions:



Before starting work, follow the procedure below to ensure the unit is not started or energized while maintenance work is being performed:

Work on the electrical equipment of the refrigerated dryer may only be carried out by a qualified electrician or trained personnel under the supervision of a qualified electrician according to local codes.

Lock the main disconnect in the "off" position in accordance with applicable lock out/tag out procedures (example: OSHA CFR 29 § 1910.147) to ensure the dryer does not restart.

Before starting work, carry out the following procedure to prevent inadvertent application of power to the refrigerated dryer:

- ☞ turn switch (1) to " 0 ".
- ☞ lock out the switch (1) using a suitable padlock.

Before restarting the refrigerated dryer, ensure that:

- no maintenance personnel are working on the refrigerated dryer.
- all tools are removed from the refrigerated dryer.
- all guard and cover panels are properly installed and secured.

See chapter 7.3 and 8.2 for starting the refrigeration.

9.2 Regular Maintenance

Period	Work to be done	see chapter
Daily	Check the condensate outlet	9.2.3
50 hours after initial start	Clean the ECO-DRAIN	9.2.5
Every month	Check ECO-DRAIN for proper operation	9.2.4
	Clean the surface of the condenser	9.2.2
Every three month	General checks	9.2.1
Every year	Clean the ECO-DRAIN	9.2.5

The maintenance periods are recommended periods and may need to be adjusted based on installation and service conditions.

9.2.1 General checks

- ☞ Inspect the electrical components of the refrigerated dryer every two to three months. Correct any malfunctioning or worn components, such as loose connections or over-heated cable immediately!



Escaping compressed air and/or refrigerant can cause injury to personnel and lead to damage to the dryer.

Maintenance

- ☞ Check all pipework, hoses and screwed fittings for leakage every two to three months and carry out a visual check for any external damage. Correct any faults immediately!



The refrigerant contained in the refrigerating system may not be vented to the open air. Always use a refrigerant recovery system when working on the refrigerant circulation. Dispose of unusable refrigerant according to environmental regulations!

9.2.2 Cleaning the condenser

Clean the condenser every month.

- ☞ Stop the refrigerated dryer by turning the switch (1) to the “off” position.
- ☞ Lock the switch (1) with a suitable padlock to prevent unauthorized switch-on.
- ☞ Clean the cooling fins of the refrigerant liquefier by blowing compressed air from the outside to the inside.

See chapter 8.2 to start the refrigerated dryer.

9.2.3 Check the condensate outlet daily as follows:

Attention!

If neither condensate nor compressed air exits, clean the ECO-DRAIN. (See chapter 9.2.5)

- ☞ Verify that condensate exits from the hose of the condensate drain outlet when the drain opens (the LED extinguishes for a short period).

9.2.4 Check ECO-DRAIN for proper operation monthly, as follows:

Check the function of the condensate drain by pressing the TEST pushbutton on the upper housing of the ECO-DRAIN. The solenoid valve of the ECO-DRAIN opens when the TEST pushbutton is pressed.

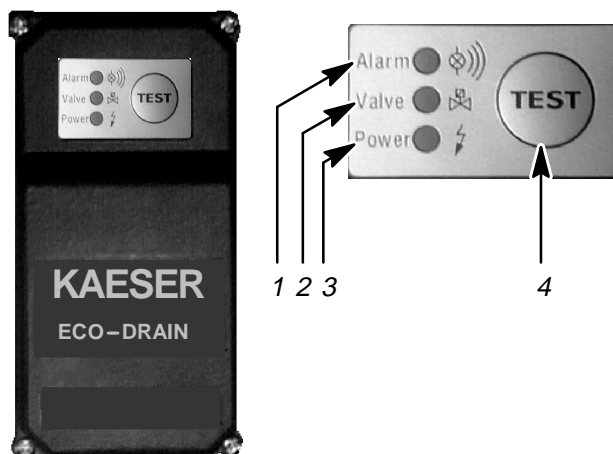

- 1 Light emitting diode "Alarm"
- 2 Light emitting diode "Valve"
- 3 Light emitting diode "Mains"
- 4 TEST-pushbutton (Condensate drain)

- ☞ Unscrew the two screws holding the left-hand side cover and remove the cover.
- ☞ Press the TEST pushbutton on the ECO-DRAIN housing.

Press the test pushbutton for at least 1 second. The valve will open every 2 to 3 seconds. The LED will flash to indicate the valve's opening and closing. Note that all accumulated condensate should drain.

Maintenance

Condensate does not drain:

- Outlet hose of the ECO–DRAIN is blocked.
If necessary, clean or replace the outlet drain hose.
 - Diaphragm valve is clogged.
See chapter 9.2.5.
 - Solenoid coil is defective.
Contact authorized KAESER distributor.
- ☞ Screw on the left–hand side panel.

9.2.5 Cleaning the ECO–DRAIN

Clean the condensate drain monthly, or more frequently depending on the degree of contamination of the compressed air.

It is recommended that the ECO–DRAIN is cleaned after the first 50 hours of service.

Maintenance work on the ECO–DRAIN is only possible with the ECO–DRAIN removed.

Initial work:

- ☞ Stop the refrigerated dryer by turning the switch (1) to the “off” position.
- ☞ Lock the switch (1) with a suitable padlock to prevent unauthorized switch–on.
- ☞ Unscrew the two screws holding the left–hand side cover and remove the cover.



Before removing up the ECO–DRAIN it must be shut off from the compressed air.

- ☞ Close the shut–off valve in the air line to the ECO–DRAIN.

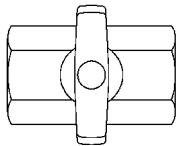

*Shut–off valve
closed*

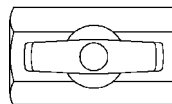

*Shut–off valve
opened*

Removing the ECO–DRAIN:

- ☞ Depressurize the ECO–DRAIN by pressing the TEST pushbutton.
- ☞ Carefully remove the insulation on the ECO–DRAIN. Do not damage, the insulation will be needed again!).
- ☞ Unscrew all fittings for the feed lines on the ECO–DRAIN.
- ☞ Unscrew the venting line and condensate drain hose.
- ☞ Unscrew the fixing screws holding the ECO–DRAIN to the angle bracket.
- ☞ Take out the ECO–DRAIN.

Attention!

The ECO–DRAIN is still connected to the power supply cable.

Maintenance

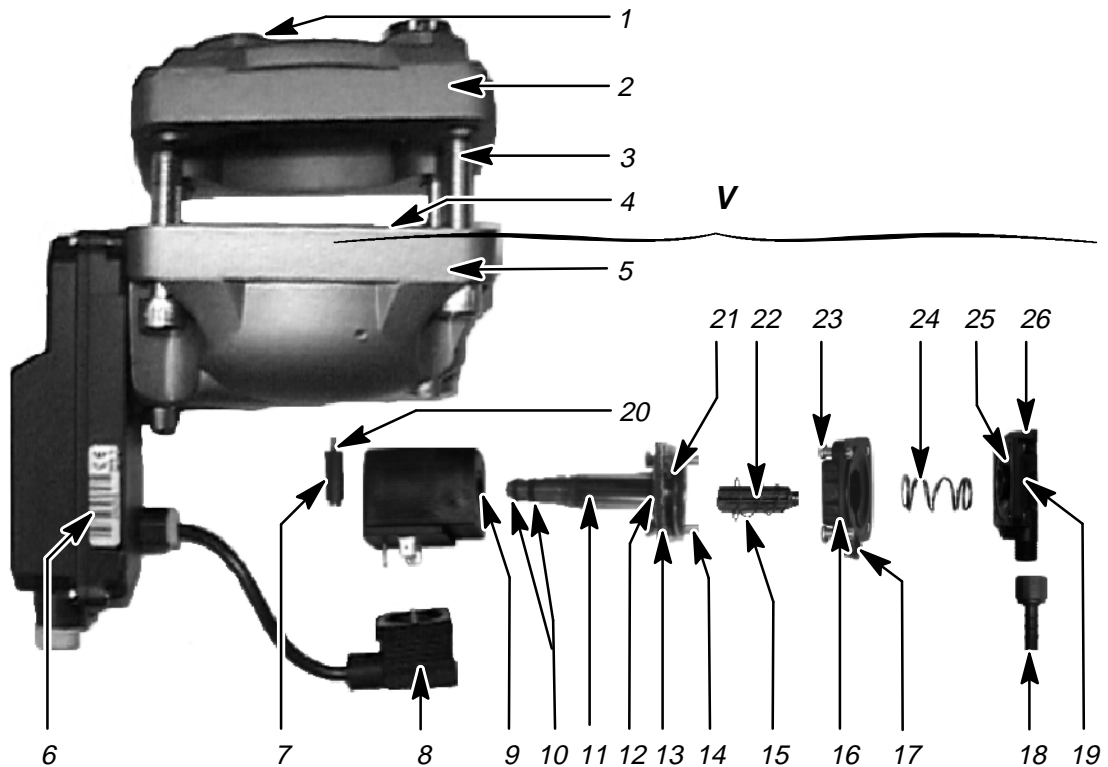

- | | |
|--------------------------------|----------------------------------|
| 1 Compressed air inlet opening | 15 Conical spring |
| 2 Housing lid | 16 Diaphragm cap |
| 3 Cheese-head screw M10 x 45 | 17 O-ring 5.5 x 1.5 |
| 4 O-ring 93 x 2 | 18 Hose connector, complete |
| 5 Housing | 19 Diaphragm seat |
| 6 Electronic control | 20 O-ring 5.5 x 1.5 |
| 7 Control-air cover | 21 Oval ring 21.8 x 1.5 x 2.5 |
| 8 Valve connector | 22 Valve core |
| 9 Solenoid | 23 Oval head screw M 5x 20 |
| 10 O-ring 5.5 x 1.5 | 24 Pressure spring for diaphragm |
| 11 Core guide pipe | 25 Diaphragm |
| 12 O-ring 11.1 x 1.78 | 26 O-ring 16 x 2 |
| 13 Flange | |
| 14 Countersunk screw M4 x 10 | V Solenoid valve subassembly |

Items in () refer to the previous illustration.

Disassembling the ECO-DRAIN:

Attention!

When disassembling the ECO-DRAIN watch for loose parts inserted into each other.

Note the assembled position of individual parts.

- ☞ Unscrew the fixing screw on the valve connector (8) and pull off the connector carefully without damaging the gasket!
- ☞ Unscrew the two oval-headed screws in the control air cover (7), and the two oval-headed screws for the diaphragm seat (19). Remove the solenoid valve assembly (V) from the housing (5).

Disassembling the solenoid valve:

Attention!

When disassembling the solenoid valve watch for loose parts inserted into each other.

Note the assembled position of individual parts.

Maintenance

- ☞ Pull the control air cover (7) and the solenoid (9) off the core guide pipe (11).
- ☞ Unscrew the four countersunk screws in the flange (13) and carefully ease the core guide pipe (11) with the flange (13).
- ☞ Unscrew the four oval-headed screws in the diaphragm cap (16) and carefully ease from the diaphragm seat (19). Watch for loose parts such as the valve core (22) with conical spring (15), diaphragm (25) with compression spring (24) and various O rings in each case!

Cleaning:

- ☞ Take out the valve core (22), conical spring (15), diaphragm (25) and compression spring (24) and clean them.



**Do not direct compressed air toward any person at any time.
Compressed air is contained energy and as such, is dangerous to life.**

Wear protective goggles when blowing out components.

- ☞ Carefully blow out the diaphragm seat (19), diaphragm cap (16), core guide pipe (11), solenoid (9) and control air cover (7) with compressed air.

Reassembling the ECO DRAIN:

Attention!

It is recommended that consumable parts, such as diaphragms, valve cores, oval rings and O rings are renewed for reasons of safety.

- ☞ Check the diaphragm (25), the presence and correct seating of the O ring (26) on the diaphragm seat (19), the O ring (17) on the diaphragm cover (16) and the O ring (20) on the control air cover (7). Renew any defective parts.
- ☞ Insert the diaphragm (25) into the diaphragm seat (19).
- ☞ Push the compression spring (24) into the recess in the diaphragm (25).
- ☞ Fit the diaphragm cap (16) on the diaphragm seat (19), ensuring correct seating of the compression spring (24)!
- ☞ Position the four countersunk screws (23) in the holes provided in the vertically assembled diaphragm cap and diaphragm seat and tighten down.
- ☞ Check the presence and correct seating of the O rings (10) and the oval ring (21) on the core guide pipe (11). Renew any defective parts.
- ☞ Fit the flange (13) on the core guide pipe and then push on the O ring (12).
- ☞ Check the valve core (22) for signs of wear, renew, if necessary.
- ☞ Check the presence and seating of the conical spring (15) on the valve core.
- ☞ Insert the valve core (22) into the core guide pipe (11).
- ☞ Place and position the core guide pipe with fitted flange and inserted valve core on the diaphragm cap.
- ☞ Insert the four countersunk screws (14) into the holes of the aligned flange, diaphragm cap and diaphragm seat and screw down tightly.
- ☞ Push the solenoid (9) over the core guide pipe (11).
- ☞ Push the control air cover (7) over the core guide pipe (11), behind the solenoid winding.
- ☞ Screw the solenoid valve assembly (V) to the housing at the control air cover (7) and the diaphragm seat (19) with the four associated oval-headed screws (5).

- ☞ Check the presence of the sealing ring for the valve plug (8).
- ☞ Plug the valve plug (8) on to the solenoid pins (9) and secure with the fixing screw provided.

Final work:

- ☞ Mount the ECO–DRAIN on the mounting bracket with the fixing screws.
- ☞ Screw on the venting line and the drain hose
- ☞ Affix all fittings for the feed lines to the ECO–DRAIN again.
- ☞ Re–attach the insulation on the ECO–DRAIN again (adhesive).
- ☞ Open the shut–off valve in the feed line again.
- ☞ Carry out a functional check of the ECO–DRAIN again (see chapter 9.2.4).
- ☞ Screw on the left–hand side panel.

See chapter 8.2 to start the refrigerated dryer.

10 Spare Parts and After Sales Service

Provide the following details for all queries and spare parts orders:
(see also the name plate)

Refrigerated dryer, model:

Serial number:

Part name:

Part order number:

Always provide the date of initial start up when making claims under warranty!

Name plate:

	Typ./Model./Type/Tipo/ Modelo/Type
	Artikel-Nr./Part-No./ Référéncja/Codice/ Artículo-N.º / Artikel-Nr.
	Baujahr/Year/Année de fabrication/Anno/Año de construcción/Bouwjaar
	Serien-Nr./Serial No./ No. de série/N. di Matricola/ Nº de Matricula/Serienr.
Kältesystem/Refrigerant system/Système frigorifique/ Circuito refrigerante/Circuito frigorífico/Koelisysteem	Kältemittel/Refrigerant/Système frigori- lique/Agente refrigerante/ Agente frigorífico/Koalmiddel
	Füllgewicht/Charge/Charge/ Carga/Peso de relleno/ Vulgewicht lb.
	Betriebsdruck HD/Working pressure HP/ Pression de fonctionnement HP/Pressione AP/ Presión de trabajo AP/Bedrijfsdruk HD psig
Luftsysteem/Air system/ Système d'air/Circuito aria/ Circuito de aire/Luftsysteem	Betriebsdruck/Working pressure/Pression de fonctionnement/Pressione di esercizio/ Presión de trabajo/Bedrijfsdruk psig
	E-Anschluß/Electrical supply/ Alimentation électrique/ Alimentazione elettrica/ Alimentación eléctrica/ Elektrische aansluiting
	Nennspannung/Rated voltage/Tension nominale/tensione nominale/ Tensión nominal/Nominale spanning V <input type="checkbox"/> 1ph <input type="checkbox"/> 3ph
	Frequenz/Frequency/ Fréquence/Frequenza/ Frecuencia/Frequentie Hz
	Nennstrom/Rated current/Courant nominal/Corrente nominale/Corriente nominal/Nominale stroom A
Umgebungstemperatur/Ambient temperature/ Température ambiante/Temperatur ambiente/tem- peratura ambiente/Omgevingstemperatuur min. 40 °F / max. 110 °F	
Dichtheit geprüft/Leakproof/Etanchéité testée/Ermetico/Hermético/Dichtheid getest <input type="checkbox"/>	

11 Appendix

11.1 Wiring Diagram

Wiring Diagram
 air dryer TE 91/121/141
 460V 3Ø 60CY

manufacturer: KAESER COMPRESSORS
 96450 COBURG
 GERMANY

c			Datum	02.07.2001	USE	KAESER KOMPRESSOREN	cover page air dryer TE 91/121/141	=	Blatt 1			
b			Bearb.	Sitter	Ersatz durch:					Ersatz für:	DTE-U0909.00	Bl.
a			Gepr.	Gegner								
A	Änderung	Datum	Name	Norm								

Lfd. Nr. No.	Benennung Name	Zeichnungsnummer (Kunde) Drawing No. (customer)	Zeichnungsnummer (Hersteller) Drawing No. (manufacturer)	Blatt Page	Anlagenkennzeichen Unit designation
1	cover page		DTE-U0909.00	1	
2	list of contents		ZTE-U0909.00	1	
3	wiring diagram power unit/power supply		STE-U0909.00	1	
4	wiring diagram control unit		STE-U0909.00	2	
5	wiring diagram control unit		STE-U0909.00	3	
6	wiring diagram Volt-free contacts		STE-U0909.00	4	
7	component legend		STE-U0909.00	5	
8	electrical component parts list controller		GTE-U0909.00	1	
9	terminal connection terminal strip -X1		KTE-U0909.00	1	
10	lay-out control panel		ATE-U0909.00	1	

c			Datum	02.07.2001	KAESER KOMPRESSOREN	list of contents air dryer TE 91/121/141	ZTE-U0909.00	=
b		Bearb.	Sittler	+				
a		Gepr.	Gegner					
B	Änderung	Datum	Name	Norm	Ersatz durch:	Ersatz für:	Ursprung:	Blatt 1 Bl.

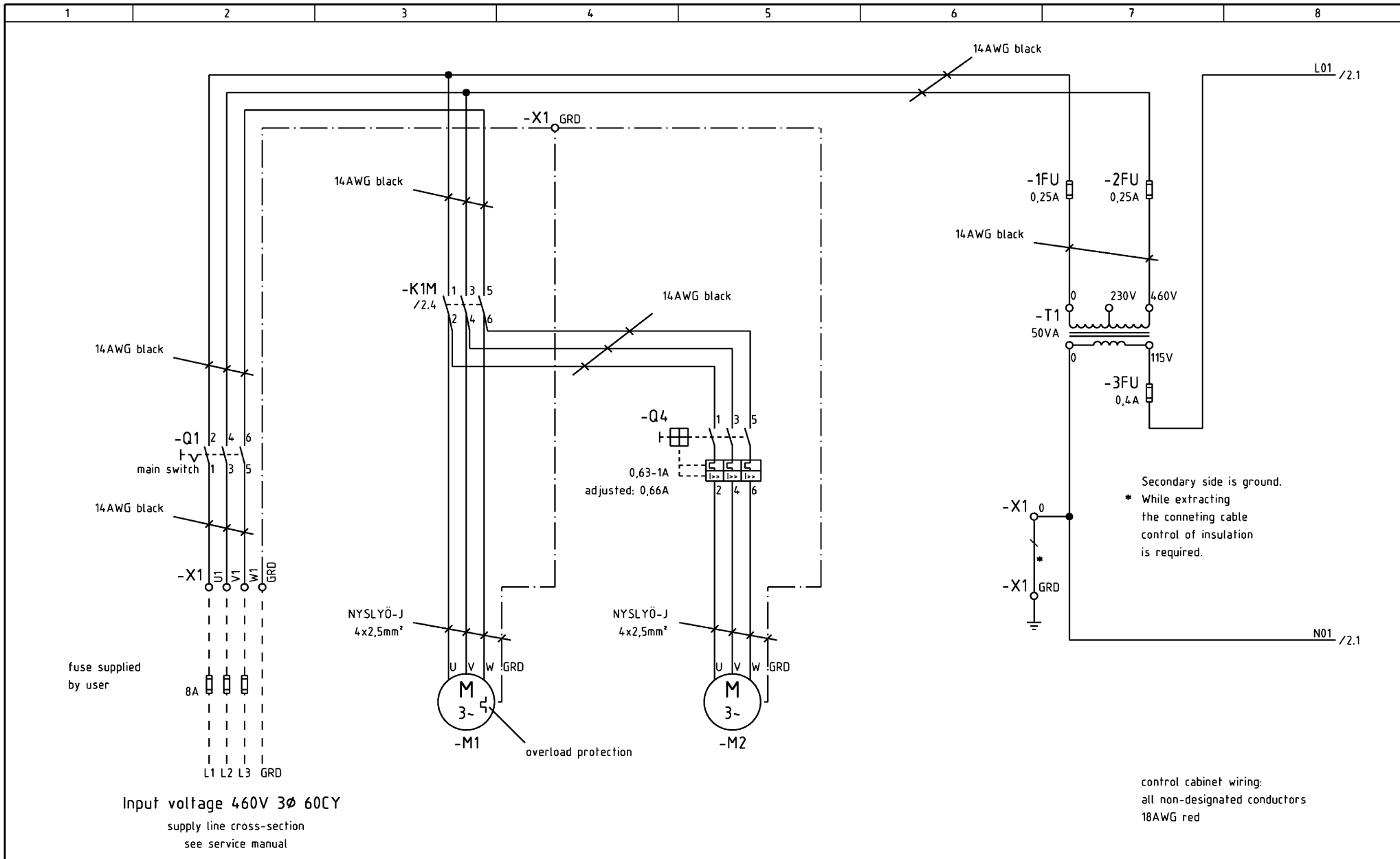

Function:		compressor motor with overload protection		vent motor		115V/1~/60CY	
Group of function:		Input voltage		power unit		control voltage tapping	
c		Datum	02.07.2001	KAESER KOMPRESSOREN	wiring diagram air dryer TE 91/121/141 power unit/power supply		
b		Bearb.	Sitter				
a		Gepr.	Gegner				
D	Änderung	Datum	Name	Norm	Ersatz durch:	Ersatz für:	Ursprung: UTEU0908
						STE-U0909.00	
							Blatt 1
							Bl.

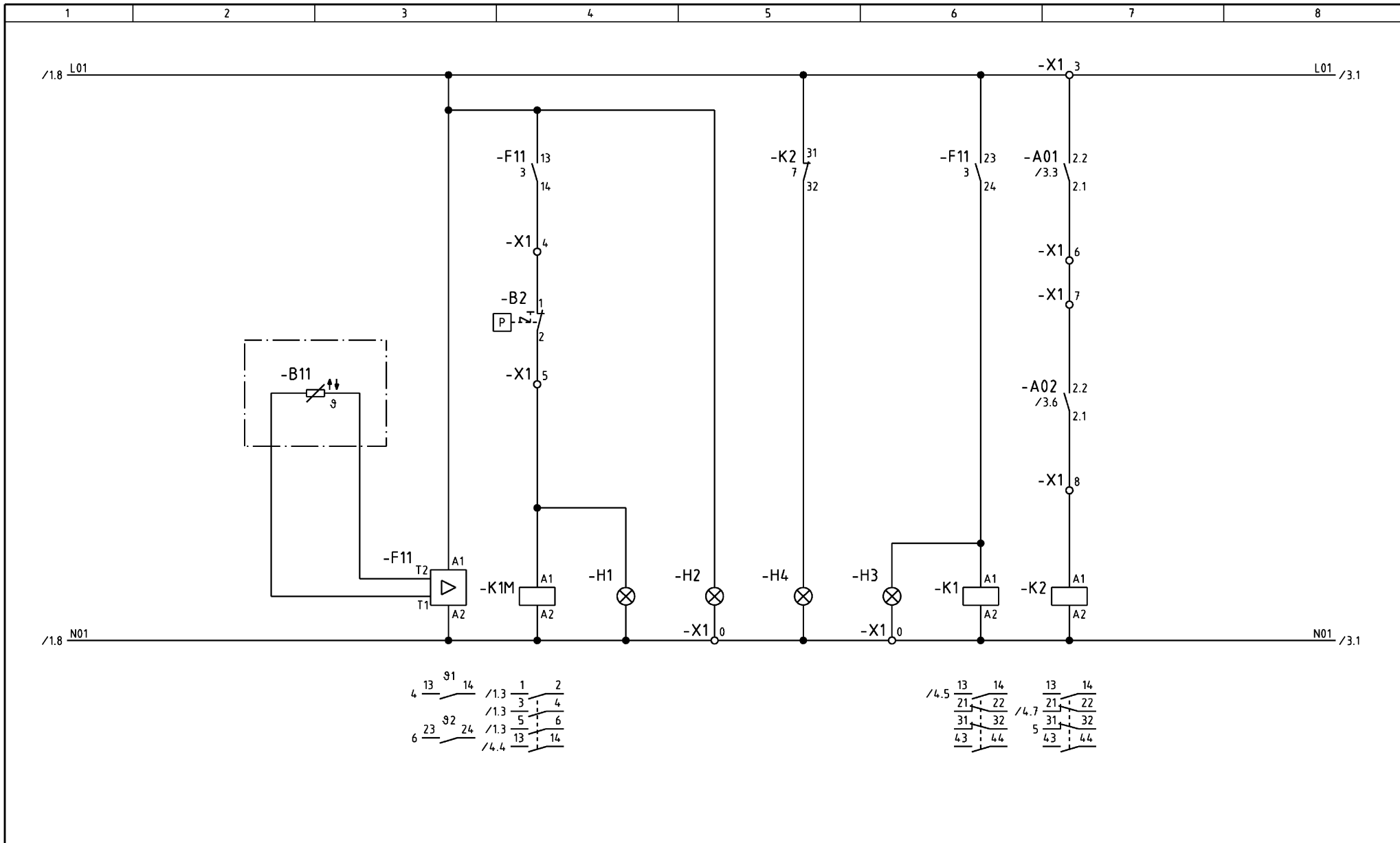

Function:				control voltage ON				FAILURE - temperature											
Function:				NTC-temperature control				motor running				FAILURE - condensate drain							
Group of function:								control unit											
c			Datum	02.07.2001				KAESER KOMPRESSOREN				wiring diagram air dryer TE 91/121/141 control unit							
b			Bearb.	Sitter															
a			Gepr.	Gegner															
D	Änderung	Datum	Name	Norm	Ersatz durch:	Ersatz für:	Ursprung:	UTEU0908				STE-U0909.00				Blatt 2 Bl.			

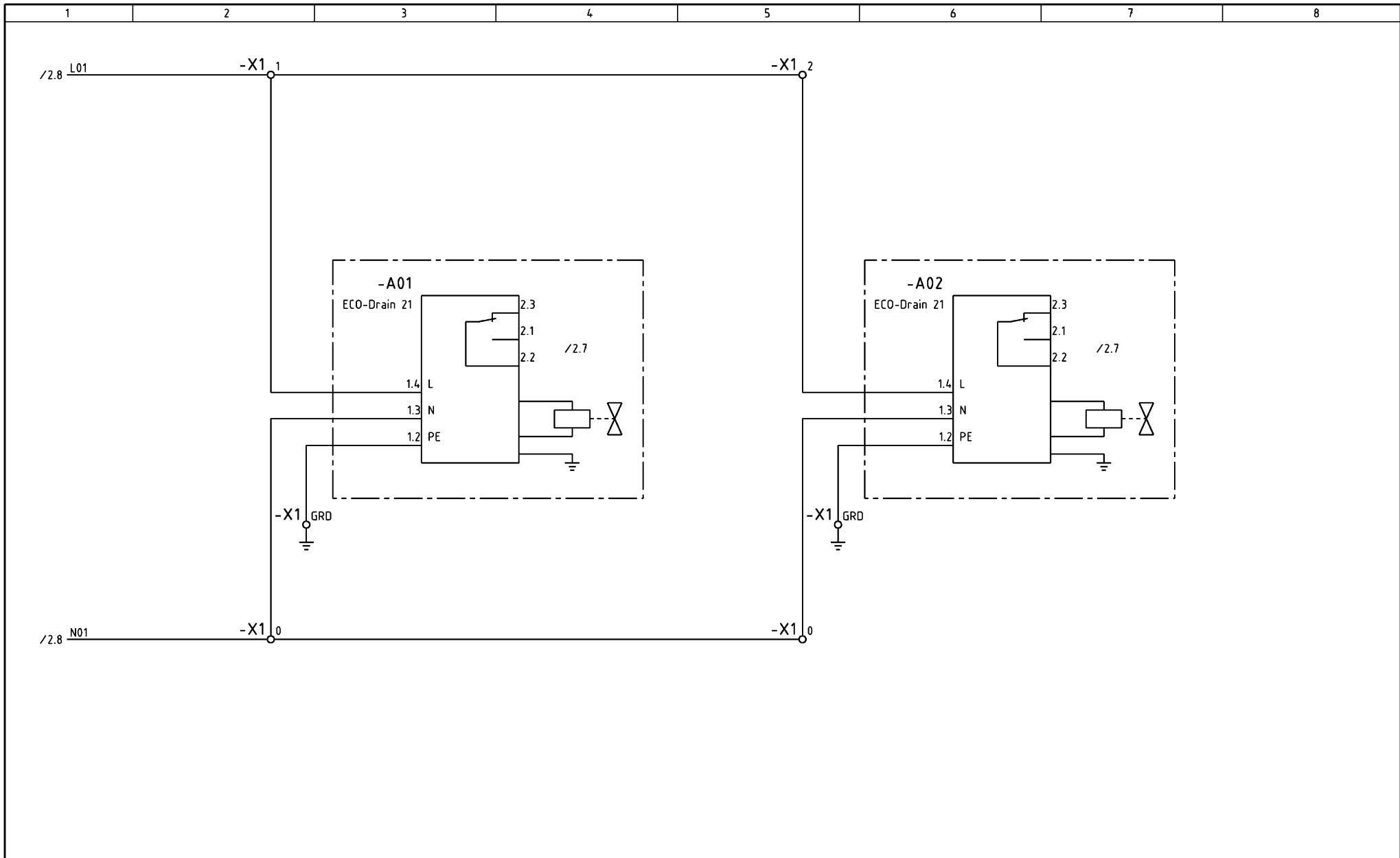

Function: automatic condensate drain

Group of function:

c			Datum	02.07.2001	KAESER KOMPRESSOREN	wiring diagram air dryer TE 91/121/141 control unit	=	+	Blatt 3
b			Bearb.	Sitter					
a			Gepr.	Gegner					
D	Änderung	Datum	Name	Norm	Ersatz durch:	Ersatz für:	Ursprung: UTEU0908	STE-U0909.00	Bl.

User's connection

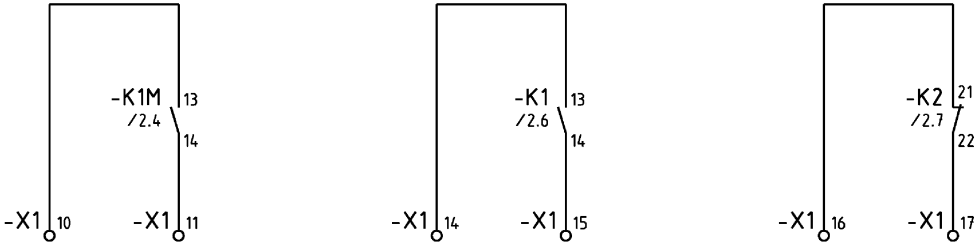

all non-designated conductors,
16AWG yellow

Function:				motor running		high dew point		FAILURE condensate drain		
Group of function:				Volt-free contacts						
c			Datum	02.07.2001	KAESER KOMPRESSOREN	wiring diagram air dryer TE 91/121/141 Volt-free contacts			=	
b			Bearb.	Sitter					+	
a			Gepr.	Gegner						
D	Änderung	Datum	Name	Norm	Ersatz durch:	Ersatz für:	Ursprung:	UTEU0908	STE-U0909.00	Blatt 4 Bl.

1	2	3	4	5	6	7	8
<p>-A01,-A02 automatic condensate drain</p> <p>-B2 safety air pressure switch</p> <p>-B11 NTC-temperature probe</p> <p>-1FU,-2FU primary control fuse</p> <p>-3FU secondary control fuse</p> <p>-Q4 circuit breaker</p> <p>-F11 NTC-thermostat</p> <p>-H1,-H2,-H3,-H4 LED indicator</p> <p>-K1,-K2 control relay</p> <p>-K1M motor starter</p> <p>-M1 compressor motor with overload protection</p> <p>-M2 vent motor</p> <p>-Q1 main switch</p> <p>-T1 control transformer</p> <p>-X1 terminal strip</p>							

c			Datum	02.07.2001	KAESER KOMPRESSOREN	component legend air dryer TE 91/121/141	= +		
b		Bearb.	Sitter						
a		Gepr.	Gegner						
E	Änderung	Datum	Name	Norm	Ersatz durch:	Ersatz für:	Ursprung: UTEU0908	STE-U0909.00	Blatt 5
									Bl.

1	2		3		4		5		6		7		8				
A Stück- zahl Qty.	B Benennung und Verwendung Description and function		C Fabrikatsbezeichnung Typ; Bestell-Nr.; Unterlagen-Nr.; Normkürzbezeichnung notwendige Techn. Daten, z.B. Steuerspannung, Frequenz, Einstellbereich Identification data Type; order No.; document No.; equipment code No.; basic technical data				D Lfd. Nr. Item	E Betriebsmittel-Kennz. nach DIN 40719, Teil 2 Identifying symbol of device		F Stromlaufplan Planabschnitt Circuit diagram sheet No.; section No.		G Einbauort Location		Concerns only the manufacturer			
			Wst.-Nr.					H Schabl. Nr.	I BZ- Pos.	J VA Kz. *)	K Eingangs- vermerk						
1	controller		7.4549.3		CKC												
1	control panel		336x366x2,5		203379.10010		CKC										
1	motor starter		A9-30-10-89		115V		7.5750.00010		ABB								
1	circuit breaker		MS225-1		0,63-1A		7.4526.00010		ABB								
2	control relay		K6-22Z		115V		7.2088.00010		ABB								
1	control transformer		50VA		230-460/115V		7.3902.00020		Block								
1	secondary control fuse		5x20		0,4A		891336.0										
1	fuse socket		USM 2		2-pole		7.3320.00020		Pump								
2	primary control fuse, 230V		ATQ 0,25		0,25A		7.3161.00150		Pump								
1	NTC-thermostat		TRN 122K-2-4		115V		7.4690.20050		Ziehl								
1	terminal strip						7.3165.10060		Wago								
	operating panel:																
1	Emergency Stop/main switch		KG20A		3-pole		890939.0		Solenoid								
2	LED indicator		19511331		green		7.5720.0		EBT								
1	LED indicator		19511332		yellow		7.5720.00020		EBT								
1	LED indicator		19511330		red		7.5720.00010		EBT								

Bei Nachbestellung von Geräten und Maschinen sind alle in den stark umrandeten Spalten B und C angegebenen Daten aufzuführen. Die Daten in den Spalten D bis G sind zusätzlich unter Nennung dieser Gerätestücklisten-Nummer anzugeben, soweit sie die Beantwortung technischer Rückfragen erleichtern. Für Ersatzteilbestellung ist zusätzlich die Angabe der Fabriknummer erforderlich, falls diese auf dem Typenschild des Erzeugnisses genannt ist.

When reordering the equipment, all data enclosed by the heavy lines of columns B and C should be stated. In addition, the data in columns D to G should be given together with the No. of this list of equipment, insofar as they are helpful in answering technical enquiries. When ordering spare parts, also quote the serial No. of the product if stated on the rating plate.

*) Versandanschrift - Kennzeichen

In Zweifelsfällen gilt die deutsche Fassung.

The German version applies in cases of doubt.

c		Datum	02.07.2001	KAESER KOMPRESSOREN	electrical component parts list air dryer TE 91/121/141 controller	GTE-U0909.00	Blatt 1 Bl.
b		Bearb.	Sitter				
a		Gepr.	Gegner				
F	Änderung	Datum	Name	Norm	Ersatz durch:	Ersatz für:	Ursprung: UTEU0908

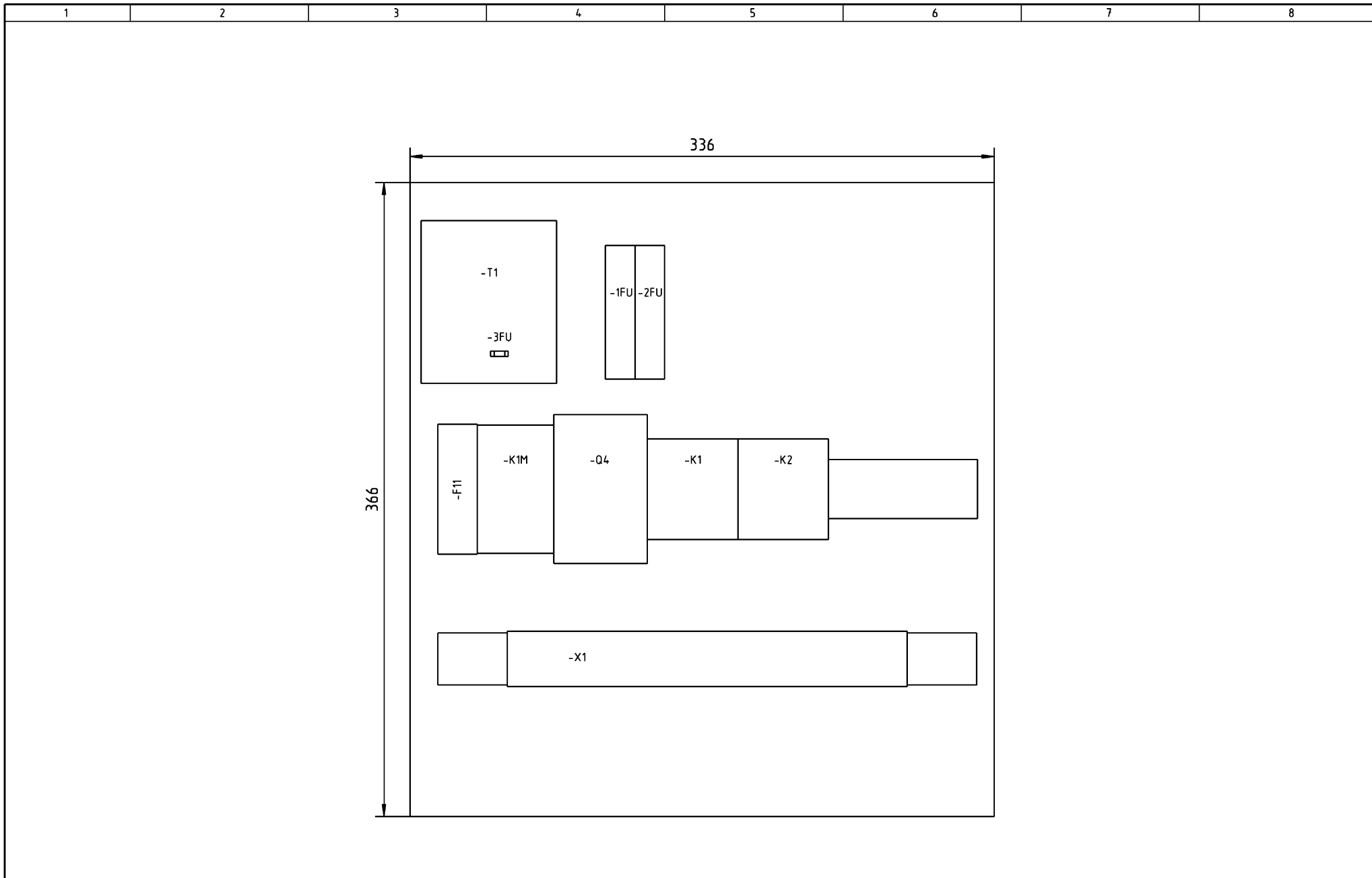

c			Datum	02.07.2001					=	
b			Bearb.	Sitter					+	
a			Gepr.	Gegner						
I	Änderung	Datum	Name	Norm	Ersatz durch:	Ersatz für:	Ursprung: UTEU0908	lay-out air dryer TE 91/121/141 control panel	ATE-U0909.00	Blatt 1 Bl.

