

# SERVICE MANUAL

USE

## Refrigerated Dryer

### Model: TD 76

GL-Nr.: BA-TD76-1.8036.00030-00  
Index: 000801

Serial No.: .....



# Table of Contents

Chapter – Page

<b>1</b>	<b>Technical Specification</b>	<b>1 – 1</b>
1.1	Refrigerated Dryer	1 – 1
1.2	Compressed Air System	1 – 1
1.3	Refrigerant System	1 – 1
1.4	Installation Requirements	1 – 1
1.5	Connections	1 – 1
1.6	Electrical Connection	1 – 2
1.7	Settings	1 – 2
1.8	Designation	1 – 2
1.9	Dimensional Diagram	1 – 2
1.10	Bypass 2 NPT	1 – 4
<b>2</b>	<b>Safety Regulations</b>	<b>2 – 5</b>
2.1	Explanation of Symbols and References	2 – 5
2.2	General Safety Instructions	2 – 5
2.3	General References	2 – 6
2.4	Spare Parts	2 – 6
2.5	Environmental Protection	2 – 6
<b>3</b>	<b>General</b>	<b>3 – 8</b>
3.1	Proper use	3 – 8
3.2	Improper use	3 – 8
3.3	Copyright	3 – 8
<b>4</b>	<b>Transport</b>	<b>4 – 9</b>
4.1	Transport Instructions	4 – 9
4.2	Packaging	4 – 9
4.3	Temporary Storage	4 – 10
<b>5</b>	<b>Construction and Operation</b>	<b>5 – 11</b>
5.1	Construction	5 – 11
5.2	Functional Description	5 – 11
5.3	Refrigerant Circulation	5 – 11
5.4	ECO–DRAIN	5 – 12
5.4.1	Functional Principle	5 – 12
5.4.2	Operational Status Indicator	5 – 13
5.5	Component Identification	5 – 14
5.6	Pipe and Instrument Flow Chart (P & I Flow Chart)	5 – 14
<b>6</b>	<b>Installation</b>	<b>6 – 17</b>
6.1	Installation Requirements	6 – 17
6.2	Compressed Air Connection	6 – 17
6.3	Condensate Drain Connection	6 – 18
6.4	Electrical Connection	6 – 18
6.5	Voltless Contacts	6 – 19

# Table of Contents



Chapter – Page

<b>7</b>	<b>Preparation For Initial Start Up</b>	<b>7 – 20</b>
7.1	Points to be Observed before Start Up	7 – 20
7.2	Points to be Observed before Switching On:	7 – 20
7.3	Ready for Operation	7 – 21
<b>8</b>	<b>Operation</b>	<b>8 – 22</b>
8.1	Instrument Panel	8 – 22
8.2	Starting the Refrigerated Dryer	8 – 23
8.3	Stopping the Refrigerated Dryer	8 – 24
8.4	Trouble shooting	8 – 25
8.4.1	Water in the compressed air system	8 – 25
8.4.2	High pressure losses via the refrigerated dryer	8 – 25
8.4.3	Pressure dew point too high	8 – 25
8.4.4	High compressed air losses	8 – 26
8.4.5	Red LED on the ECO–DRAIN housing flashes	8 – 26
8.4.6	The safety pressure switch shuts down the refrigerated dryer	8 – 26
<b>9</b>	<b>Maintenance</b>	<b>9 – 27</b>
9.1	Maintenance Instructions:	9 – 27
9.2	Regular Maintenance	9 – 27
9.2.1	General checks	9 – 27
9.2.2	Cleaning the condenser	9 – 28
9.2.3	Check the condensate outlet daily as follows:	9 – 28
9.2.4	Check ECO–DRAIN for proper operation monthly, as follows:	9 – 28
9.2.5	Cleaning the ECO–DRAIN	9 – 29
<b>10</b>	<b>Spare Parts and After Sales Service</b>	<b>10 – 32</b>
<b>11</b>	<b>Appendix</b>	<b>11 – 33</b>
11.1	Wiring Diagram	11 – 33
11.2	Maintenance Schedule	11 – 41

## 1 Technical Specification

### 1.1 Refrigerated Dryer

Model .....	TD 76
Condensate volume under nominal conditions* .....	84 oz/h
Weight .....	632 lbs
Cooling air volume .....	1880 cfm
Noise level to CAGI–Pneurop .....	< 70 dB(A)
at 1 m distance (free sound field measurement)	

\* See chapter 1.2 for nominal conditions.

#### Drawings:

P & I flow chart .....	TKTTD76–00017
(Pipework and instrument flow chart)	
Electrical diagram .....	STD76–U0909
Dimensional drawing .....	T 9257.00
By-pass piping .....	203737.0

### 1.2 Compressed Air System

Flow volume .....	285 scfm
Pressure drop .....	1.75 psid
Pressure dewpoint .....	35 °F
at 100 °F air inlet, 100 psig and 100 °F ambient temperature.	
Maximum gauge working pressure .....	230 psig

### 1.3 Refrigerant System

Refrigerant .....	R 134a
Maximum quantity .....	3.2 lbs
Permissible gauge working pressure .....	260 psig

### 1.4 Installation Requirements

Max. elevation above sea level of installation .....	3000 ft.
(for all elevations above please contact authorized KAESER distributor)	
Min. ambient temperature .....	40 °F
Max. ambient temperature .....	110 °F
Maximum compressed air inlet temperature .....	130 °F

### 1.5 Connections

Compressed air outlet .....	2 NPT
Condensate drain connection (hose connection) .....	3/8
Service connection (Schrader valve) .....	7/16 UNF

## Technical Specification

---

### 1.6 Electrical Connection

Main voltage .....	575 V ± 10 % 3-phase
Full load current, FLA .....	3.1 A
Frequency .....	60 Hz
Recommended main disconnect fuses (Dual element or time-delay) .....	6 A
Recommended power supply cable (Cu multi-stranded ) cross-section .....	14 AWG

**Attention!**

**Maximum dual element time-delay fuses are selected according to 1996 N.E.C. Article 240-6, 430-52 and Tables 430-148 & 150.**

**Select multi-strand copper core wire at 40°C ambient temperature according to 1996 N.E.C. 110-14(c), 220-3, 310-15, Table 310-16, 430-6, 430-22 and Tables 430-148 & 150.**

### 1.7 Settings

**Safety pressure switch (refrigerant)**

switching point (fixed)

P<sub>OFF</sub> ..... 265 psi**Thermostat**

regulates pressure dewpoint to ..... approx. 35 °F

switching point for volt-free

"High Pressure Dewpoint" contact ..... approx. 54 °F

### 1.8 Designation

The nameplate of the refrigerated dryer is located on the front left below the cooling air inlet (see chapter 10 for an illustration of the nameplate).

### 1.9 Dimensional Diagram

(see next page)

# Technical Specification

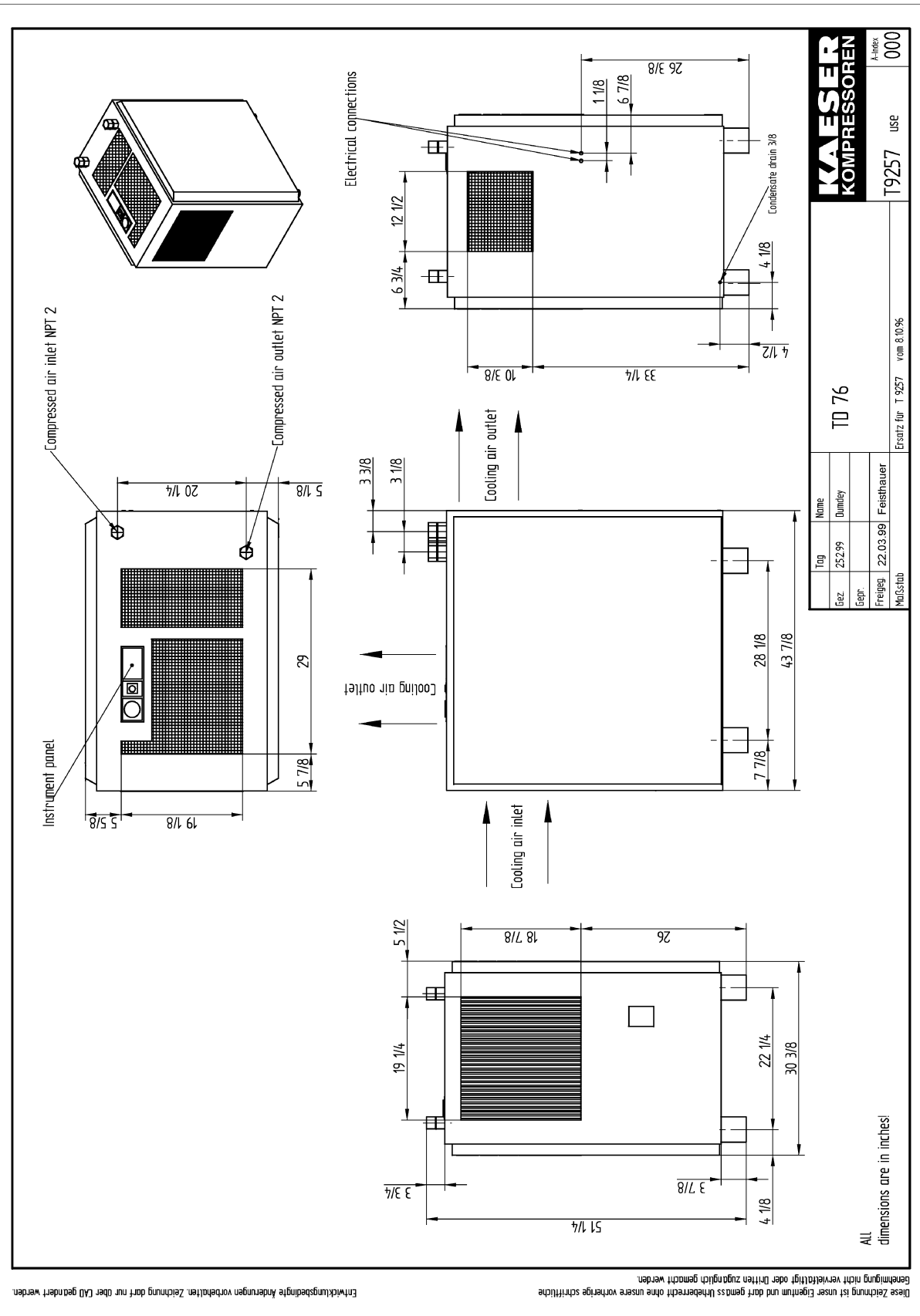

Name		TD 76	
Tag	25299	Dummy	
Gez.	22.03.99	Feisthauer	
Gepr.			
Freigeig.			
Maßstab	Ersatz für T 9257 vom 8.10.96		
A-Index		T9257	use
A-Index		000	

ALL dimensions are in inches!

Diese Zeichnung ist unser Eigentum und darf gemäss Urheberrecht ohne unsere vorherige schriftliche Genehmigung nicht veröffentlicht oder Dritten zugänglich gemacht werden.  
Entwicklungsbedingte Änderungen vorbehalten. Zeichnung darf nur über CAD geändert werden.

1.10 Bypass 2 NPT

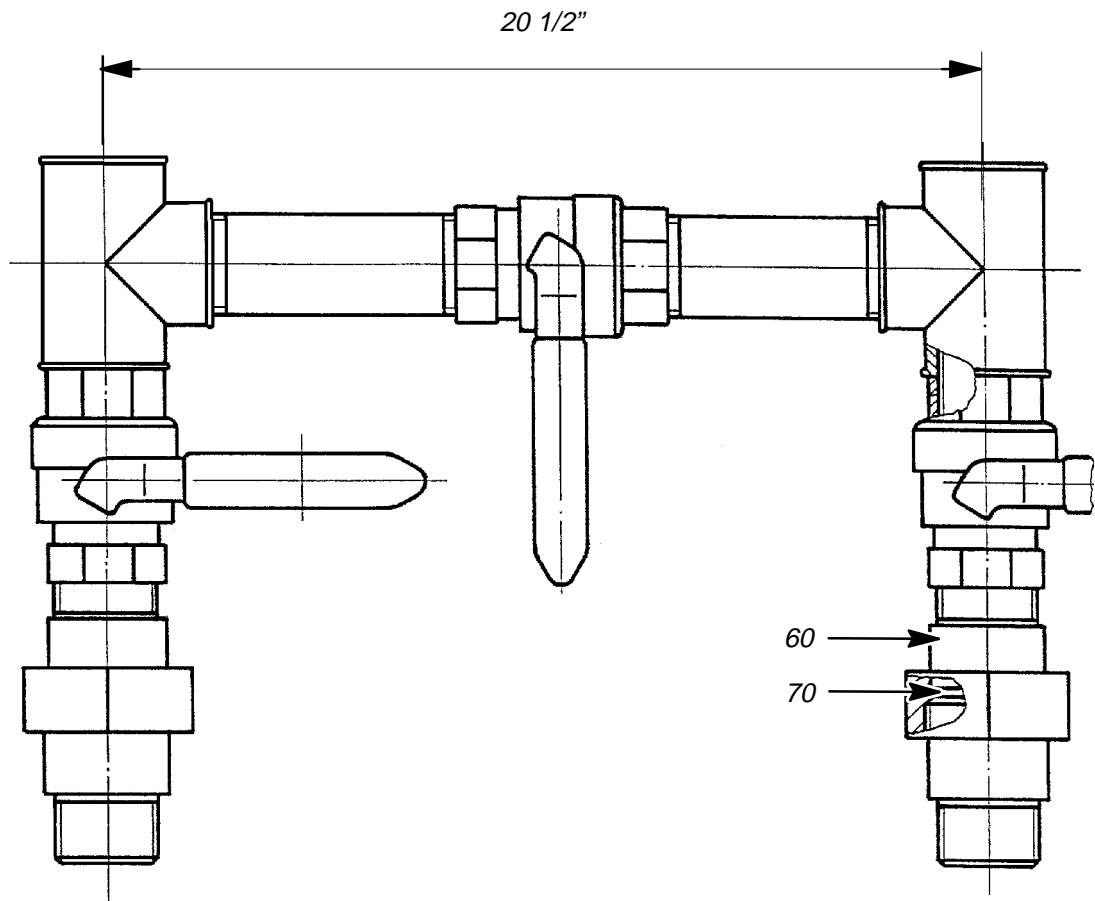



## 2 Safety Regulations

Read this service manual very carefully and observe all cautionary references before the initial start of this refrigerated dryer and before carrying out any maintenance on the unit.

### 2.1 Explanation of Symbols and References



This symbol is placed before all safety references where there is danger to life and limb. It is especially important that any associated instructions are followed explicitly and that extreme care is taken when performing the indicated task(s). For their own protection, inform all other users of these safety rules. Observe general safety and accident prevention regulations as well as the safety rules laid down in this service manual.

**Attention!**

This symbol is placed by text where considerable attention must be paid to recommendations, regulations, references and correct sequence so that damage and/or destruction of the compressor and/or other equipment is prevented.



This symbol identifies environmental care measures.



This symbol indicates operations to be carried out by the operator or service technician.

- This bullet identifies listings.

### 2.2 General Safety Instructions

Work on power driven systems may only be carried out by trained or instructed personnel or by specialized personnel.

Work on the electrical equipment of the refrigerated dryer may only be carried out by a qualified electrician or trained personnel under the supervision of a qualified electrician according to the NEC and any applicable local codes.

Work on the refrigeration system may only be carried out by a certified refrigeration technician (according to 40CFR Part 82).

## 2.3 General References



Work on power driven systems may only be carried out by trained or instructed personnel or by specialized personnel.

Work on the electrical equipment of the refrigerated dryer may only be carried out by a qualified electrician or trained personnel under the supervision of a qualified electrician according to the NEC and any applicable local codes.

Work on the refrigeration system may only be carried out by a certified refrigeration technician (according to 40CFR Part 82).

The refrigerated dryer contains activated electrical components. Carry out the following measures in the sequence shown before attempting any work on the electrical system:

1. Lock the main disconnect in the "off" position in accordance with applicable lock out/ tag out procedures (example: OSHA CFR 29 § 1910.147) to ensure the refrigerated dryer does not restart.
2. Ensure the unit cannot be switched on again
3. Check that no voltage is present
4. Lock the isolation shut-off valve in the "closed" position and vent all compressed air trapped in the refrigerated dryer or in the piping between the dryer and the isolation shut-off valve in accordance with applicable lock out/ tag out procedures (example: OSHA CFR 29 § 1910.147).

The refrigerated dryer contains systems subject to high pressures. Before any maintenance work is carried out, vent and shut off the pressure lines.



Escaping compressed air and/or refrigerant can cause injury to personnel and lead to damage to the dryer.



The refrigerant contained in the refrigerating system may not be vented to the open air. Always use a refrigerant recovery system when working on the refrigerant circulation. Dispose of unusable refrigerant according to environmental regulations!

**Attention!**

Any alterations or reconstruction carried out without the prior written authorization of KAESER COMPRESSORS Inc. will invalidate the warranty.

## 2.4 Spare Parts

The use of KAESER original parts guarantees safe and reliable operation of the refrigerated dryer.

## 2.5 Environmental Protection

Condensate drainage



The condensate accumulated during the drying of compressed air must be removed via a suitable drainage system, collected in special

canisters and disposed of according to federal and local environmental regulations.

## Maintenance materials/wear items/replacement parts



Ensure that all wear items, maintenance and replacement parts accumulated during operation of the refrigerated dryer are disposed of according to environmental regulations.

## 3 General



**The service manual must always be available for use at the location of the refrigerated dryer.**

### 3.1 Proper use

The refrigerated dryer is intended solely for drying compressed air.

Any other use outside of this purpose is considered improper. The manufacturer cannot accept liability for any damage caused by improper use; the user alone is liable for any risks incurred.

Proper use of the dryer includes compliance with the installation, removal, servicing, operation and maintenance instructions as specified by the manufacturer.

### 3.2 Improper use



**Never direct compressed air toward persons. Compressed air is a concentrated form of energy and as such is dangerous to life.**

### 3.3 Copyright

© KAESER COMPRESSORS, INC.

All rights reserved. No part of this manual may be reproduced in any form without permission of KAESER COMPRESSORS, INC.

# Transport

## 4 Transport

### 4.1 Transport Instructions

**Attention!**

Under no circumstances lift the refrigerated dryer with the compressed air inlet and outlet connections or lay the refrigerated dryer on its side. Serious damage can result from such treatment of the refrigerated dryer.

To prevent damage to the panelling of the refrigerated dryer always use a jack lift or a forklift truck for transport.

- Always mount the refrigerated dryer on a suitable transporting medium (pallet or wooden base) during transport.

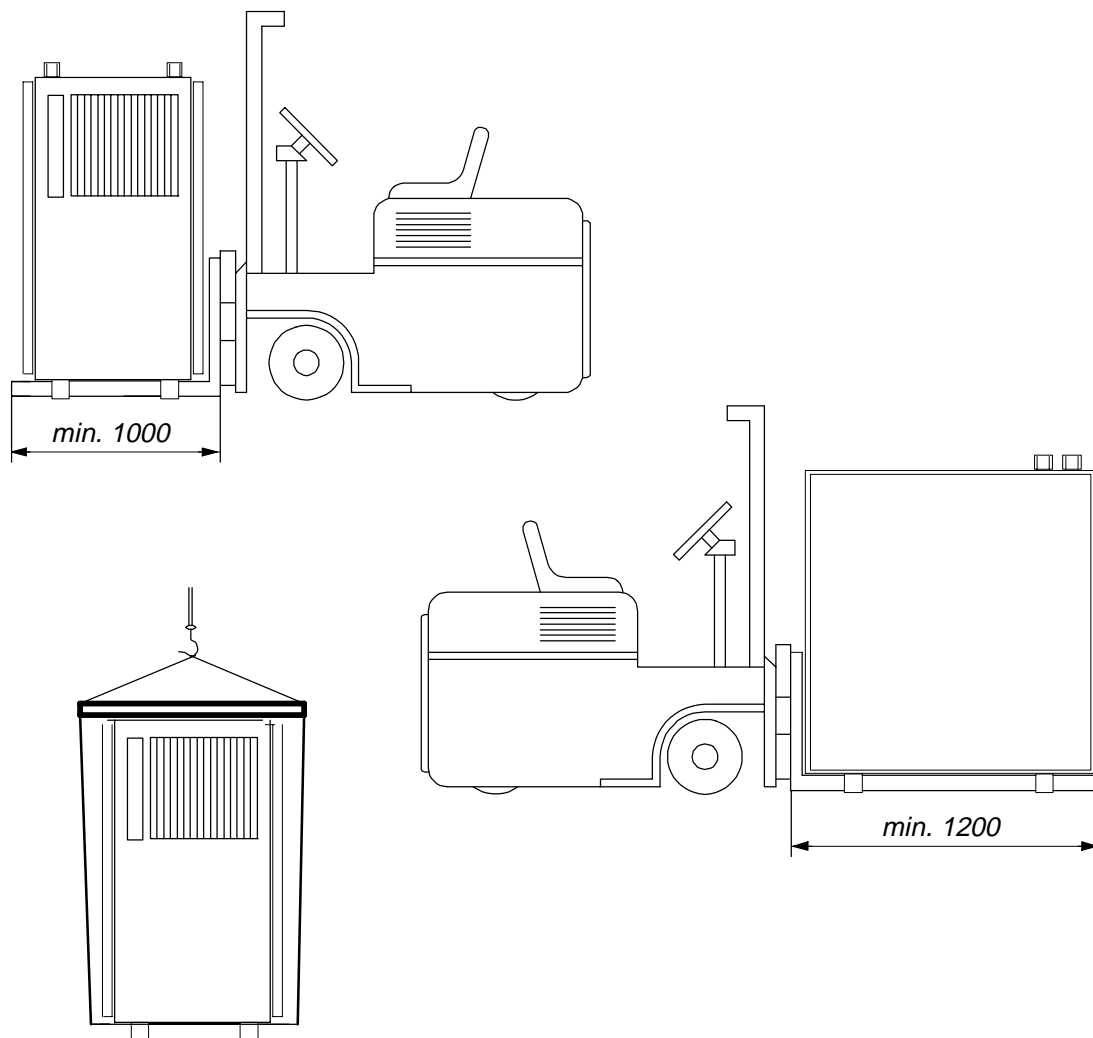
**Attention!**

Do not exert any side forces on the refrigerated dryer with lifting equipment

### 4.2 Packaging

The packaging provided with this compressor as delivered is intended to safeguard the package against normal road transport damage. Please dispose of in an environmentally friendly way and arrange for it to be recycled if possible.

## 4.3 Temporary Storage

Store the refrigerated dryer in an enclosed space, regardless of whether it is packaged or not.

The storage temperature should not fall below  $-13^{\circ}\text{F}$  and not rise above  $140^{\circ}\text{F}$ .

**Attention!**

**Before initial start, wait until the temperature of the refrigerated dryer has adapted to the ambient temperature.**

## 5 Construction and Operation

Numbers enclosed in parentheses ( ) correspond with the numbered items in the Pipe and Instrument Flow Diagram (see chapter 5.6).

### 5.1 Construction

The main component of the refrigerated dryer comprises a combined heat exchanger. It consists of the two following stages:

1st. stage: air to air heat exchanger (1)

2nd. stage: air to refrigerant heat exchanger (2)

The refrigerant circulation is automatically regulated by a thermostat (13). A moisture separator and condensate drain (3) are located in series with the heat exchanger.

A safety pressure switch (9) is fitted in the refrigerant circulation system as a protection against excessive pressure.

A thermal overload switch protects the refrigerant compressor (11) against current overloads and high temperatures.

### 5.2 Functional Description

The dryer will typically receive warm, compressed air which is completely saturated with moisture. The dryer will remove nearly all of this moisture by cooling the compressed air. As the air cools, the moisture condenses into liquid which can be easily separated and removed from the compressed air.

The cooling of the compressed air is accomplished in two steps:

- As the warm, saturated, compressed air enters the dryer, the air is pre-cooled in an air to air heat exchanger (1). The heat that is removed from the compressed air entering the dryer is used to re-heat the compressed air before it exits the dryer.
- The pre-cooled air enters the evaporator (refrigerant heat exchanger) (2) which cools the air to approximately 35 °F.

The moisture that is condensed from the compressed air during cooling is collected in the moisture separator (3). The moisture separator will also filter out most dirt particles to further clean the compressed air. The collected moisture is then drained from the compressed air by an automatic drain trap (5).

The compressed air is then re-heated in the air to air heat exchanger (1) before it exits the dryer. This final re-heating of the air helps protect system piping and components by preventing the formation of condensation in the components after the dryer.

For optimum power savings, the refrigerant compressor (11) is switched off and on by a thermostat. This ensures that the compressor is not running when further cooling is not required as is typical during periods of low compressed air usage.

### 5.3 Refrigerant Circulation

The dryer is able to cool the compressed air by using a refrigeration system not unlike a typical home refrigerator. Cooling is achieved by transferring heat from the compressed air to the refrigerant by vaporizing (boiling) the refrigerant, thereby turning the refrigerant into a gas. A more complete description of this process is given below:

The refrigerant enters the hermetically sealed compressor (11) as a low pressure gas. The gas is compressed to a suitable pressure to ensure that the gas is nearly saturated. The high pressure refrigerant gas flows to the condenser (10) where heat is removed from the refrigerant. As the high pressure refrigerant gas is cooled, the refrigerant becomes a liquid.

## Construction and Operation

The high pressure liquid is then forced through a capillary tube (7). By forcing the refrigerant through this restriction, the refrigerant becomes a low pressure liquid. The low pressure, liquid refrigerant enters the evaporator (2) where heat from the compressed air is transferred to the refrigerant. The added heat causes the refrigerant to boil and results in the refrigerant becoming a low pressure gas. This becomes an endless cycle which allows the refrigerant to simply remove heat from the compressed air and expel it to the ambient air.

### 5.4 ECO-DRAIN

#### 5.4.1 Functional Principle

Items referred to in ( ) refer to the items in the following figures.

- The accumulating condensate enters the collector tank (2) via the inlet openings (1). The diaphragm valve (4) is closed.
- A capacitive sensor (3) continuously registers the liquid level and passes a signal to the electronic control (7) as soon as the chamber is full. The pilot valve is activated and the diaphragm valve (4) opens the outlet line (5). When the ECO-DRAIN is empty, the outlet line is closed again before compressed air can escape.

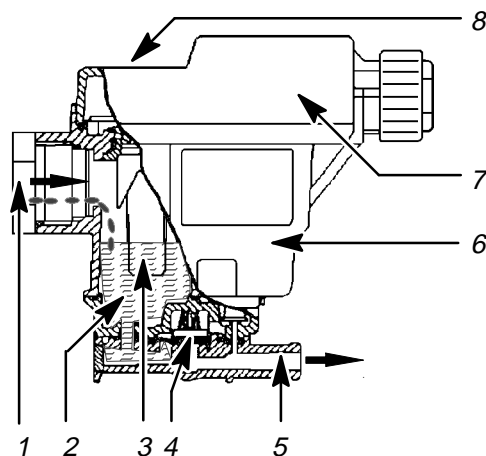

- 1 Inlet opening
- 2 Collector
- 3 Level detector
- 4 Diaphragm valve

- 5 Outlet line
- 6 Housing
- 7 Electronic control
- 8 Light-emitting diode

- If a fault occurs (e.g. overload), the valve cycles on and off continuously to clear the fault. The light-emitting diode flashes.



## Construction and Operation

---

### 5.4.2 Operational Status Indicator

The operational status of the condensate drain is indicated by a red LED (8) on the housing of the ECO-DRAIN. The LED will indicate one of the following conditions:

- 1 LED on permanently:  
the drain is operational
- 2 LED extinguishes for a short period:  
the drain is discharging moisture
- 3 LED flashing continuously:  
a fault exists

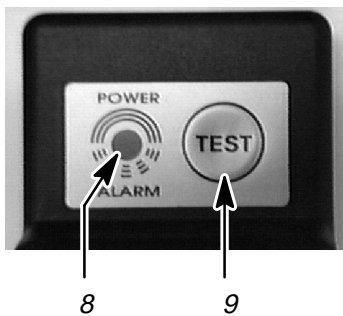

- 8 *Operational status – light emitting diode*  
9 *TEST pushbutton (condensate drain)*

## Construction and Operation

### 5.5 Component Identification

Numbers in ( ) correspond to those in the Pipe and Instrument Flow Chart. (P & I Flow Chart).

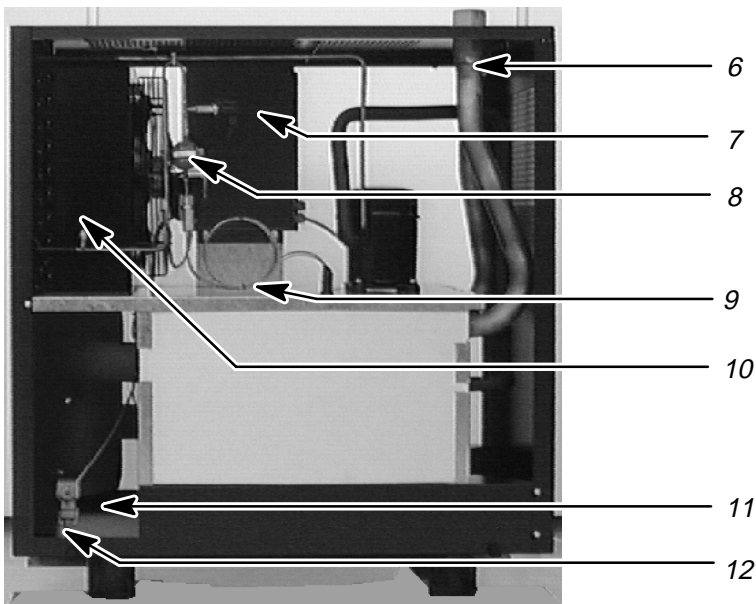
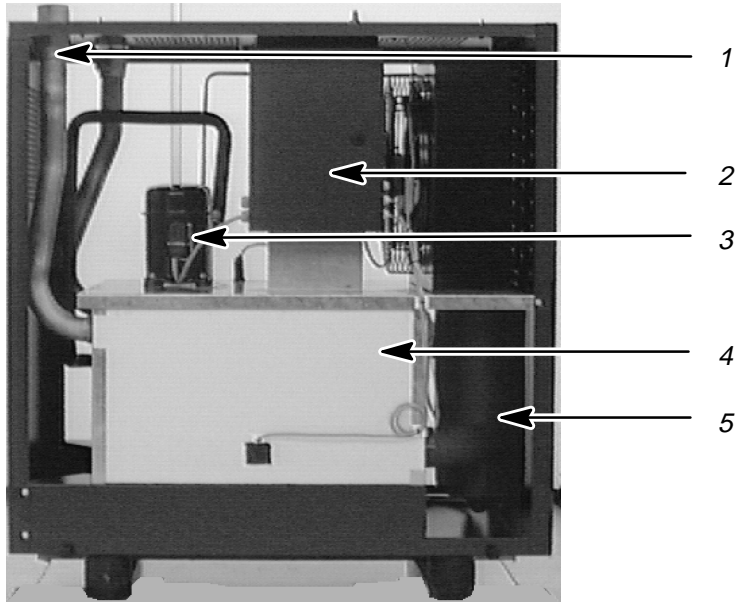

- |                               |                           |
|-------------------------------|---------------------------|
| 1 Compressed air outlet       | 7 Heat exchanger (1), (2) |
| 2 Safety pressure switch (9)  | 8 Condensate ECO-DRAIN    |
| 3 Filter dryer (8)            | 9 Drain hose (5)          |
| 4 Condenser (10)              | 10 Compressed air inlet   |
| 5 Refrigerant compressor (11) | 11 Control cabinet        |
| 6 Capillary tube (7)          | 12 Moisture separator (3) |

### 5.6 Pipe and Instrument Flow Chart (P & I Flow Chart)

(see following pages)

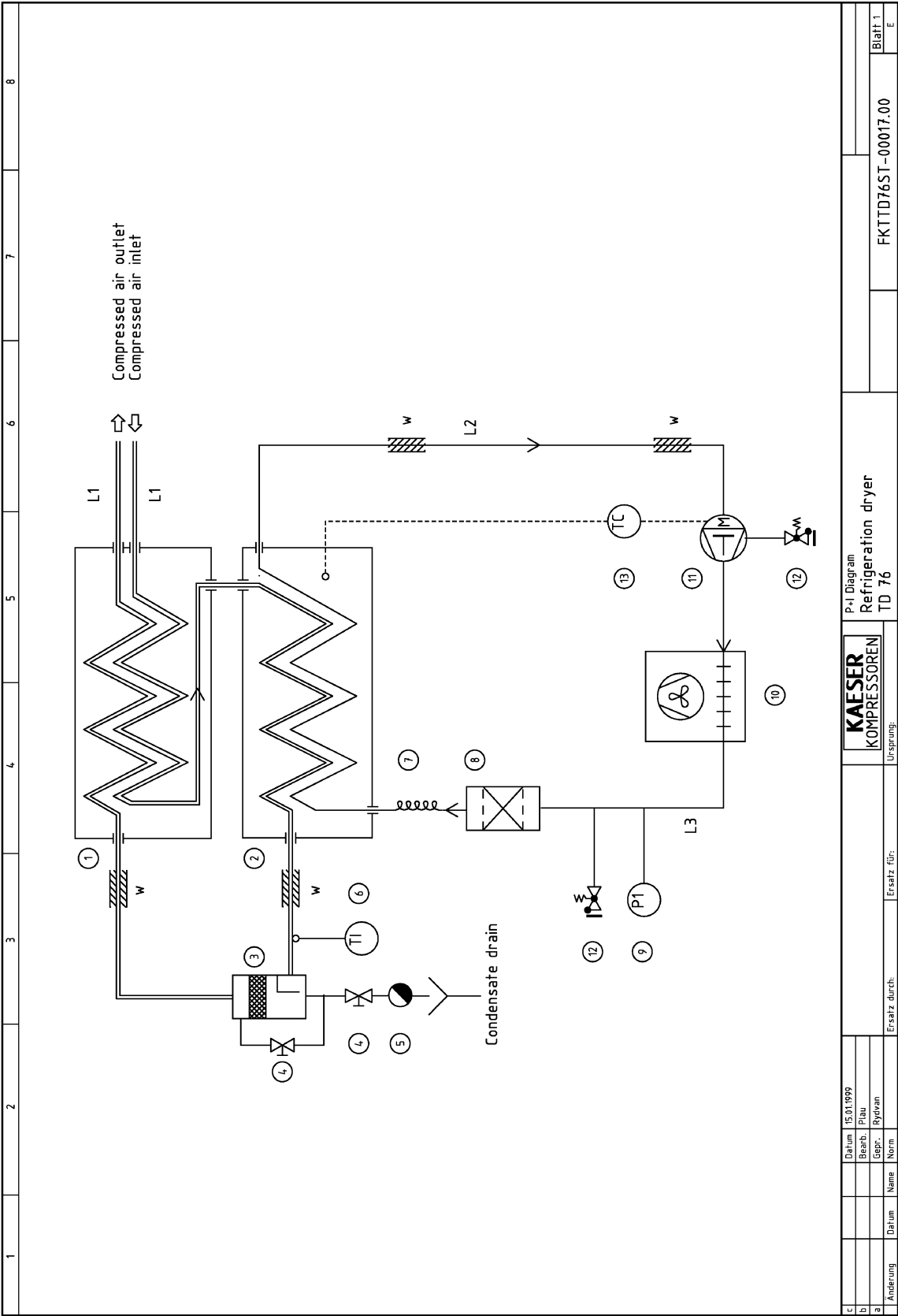

c	Datum	15.01.1999	Ersatz durch:		Ersatz für:		P-H Diagram		FKTTD76ST-00017.00		Blatt 1	
b	Bearb.	Plau	Ersatz durch:		Ersatz für:		Refrigeration dryer				E	
a	Gepr.	Rydvan	Ersatz durch:		Ersatz für:		TD 76					
	Name		Ersatz durch:		Ersatz für:		KAESER					
	Datum		Ersatz durch:		Ersatz für:		KOMPRESSOREN					
	Norm		Ersatz durch:		Ersatz für:		Ursprung:					

1	2	3	4	5	6	7	8
1	Air to air heat exchanger				} heat insulated		
2	Air to refrigerant heat exchanger (Evaporator)						
3	Condensate separator						
4	Shut-off valve						
5	Condensate drain						
6	Pressure dew point indicator TI						
7	Capillary tube (Refrigerant injection)						
8	Filter dryer						
9	Safety pressure switch						
10	Refrigerant liquefier (air cooled condenser)						
11	Refrigerant compressor (hermetic)						
12	Service connection (Schrader valve)						
13	Thermostat						
	<b>Piping:</b>						
	L1	Pipe (Cu) 54 x 2,0 DIN 1708					
	L2	Pipe (Cu) 12 x 1,0 DIN 1708					
	L3	Pipe (Cu) 8 x 1,0 DIN 1708					
	w	heat insulated					
c	Datum	15.01.1999					
b	Bearb.	Plau					
a	Gepr.	Rydvan					
	Norm						
Änderung	Datum	Name					
	Ersatz durch:		Ersatz für:		Ursprung:		
					<b>KAESER</b> <b>KOMPRESSOREN</b>		
					P+I Diagram legend Refrigeration dryer TD 76		
					FKTTD76ST-00017.00		Blatt 2
							E

## Installation

### 6 Installation

#### 6.1 Installation Requirements

The refrigerated dryer must be installed in a dry and dust free space. To ensure adequate room for the maintenance of the refrigerated dryer, the minimum distances must be complied with (see following sketch).

Install the dryer on an even flat surface. Special foundations for the installation of the refrigerated dryer are not necessary.

See chapter 1.4 for the the ambient temperature and maximum height of the place of installation.

**Attention!**

To ensure adequate ventilation and air circulation, be sure to allow for the indicated minimum clearances at the cooling air inlet and exhaust.

The refrigerated dryer must not be installed in the air inlet and/or cooling air outlet area of a compressor package.  
The compressed air to be dried and the ambient air in the compressor space may not contain any acid-forming or other aggressive materials.

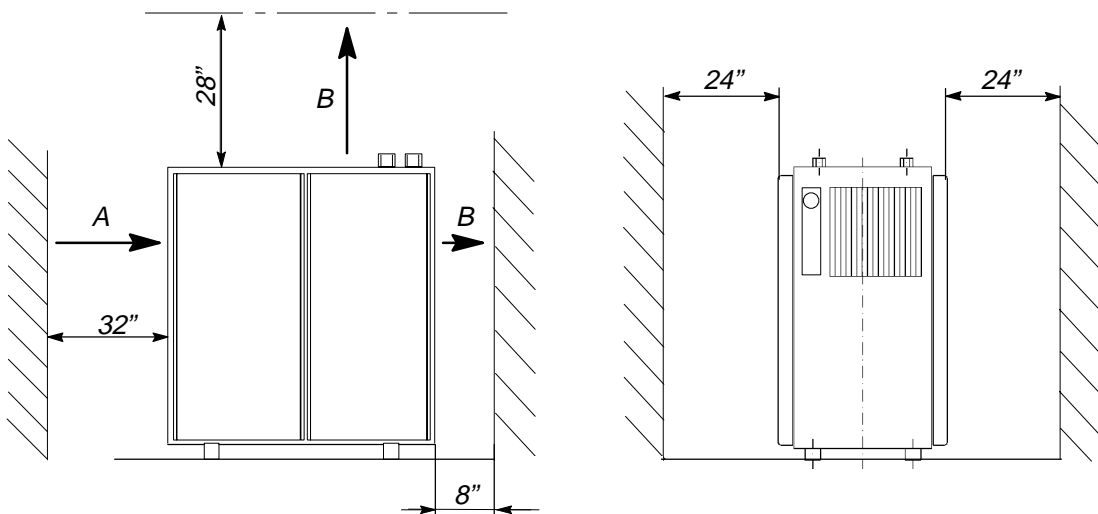

Measurements shown are minimum recommendations

A Cooling air inlet

B Cooling air outlet

**Attention!**

Installing of inlet and/or exhaust air ducting without prior written approval from of KAESER COMPRESSORS Inc. is not permitted.

#### 6.2 Compressed Air Connection

**Attention!**

Use flexible connecting pipes at the compressed air inlet and discharge to ensure vibration isolation, prevent strain on piping connections and allow easy installation.  
To avoid damage, do not overtighten the compressed air connections.

## Installation

The refrigeration dryer is piped ready for operation.

### Shut-off valves:



**All power driven systems must be equipped with a main stop system for all forms of energy feed, the operation of which determines the start and stop of the energy supply to the system.**

The compressed air inlet and outlet pipework must be provided with shut off arrangements (e.g. ball valves).

### Bypass:

The compressed air inlet and outlet should be fitted with a bypass.

See diagram in chapter 1.10 for details of the bypass.

### Installation notes:

Identification numbers in ( ) correspond to the diagram of the bypass in chapter 1.10.

- ☞ Screw the threaded part of the union fitting (60) (with sealing tape) into the corresponding connection for the compressed air inlet or outlet.
- ☞ Insert the flat gasket (70) and fit the bypass by screwing down and tightening the union nut of the fitting (60).
- ☞ Check the fittings for leakages.

See chapter 1.5 for the dimensions of the connector fittings.

## 6.3 Condensate Drain Connection

A hose connection is provided for drainage of the condensate. See chapter 1.5 for the dimensions.

**Attention!**

**Use caution when attaching the condensation drain line to ensure that the condensate flow is not obstructed.**



**The condensate must be drained and collected in a suitable container. It must be disposed of in accordance with federal and local environmental codes.**

## 6.4 Electrical Connection



**The main power supply and overcurrent protection must be installed by a qualified electrician in accordance with NEC, OSHA and any applicable local codes.**

**For fuse and wire recommendations, see chapter 1.6.**

The refrigerated dryer is delivered completely wired, ready for connection to the power supply. This connection must be made as detailed in the electrical diagram (see chapter 11.1). See the dimensional diagram (see chapter 1.9) for the position and size of the cable entry into the refrigerated dryer.

**Attention!**

**Maximum dual element time-delay fuses are selected according to 1996 N.E.C. Article 240-6, 430-52 and Tables 430-148 & 150.**

**Select multi-strand copper core wire at 40°C ambient temperature**

according to 1996 N.E.C. 110–14(c), 220–3, 310–15, Table 310–16, 430–6, 430–22 and Tables 430–148 & 150.

Wire temperature rating:

1.25 x FLA (see chapter 1.6)	wire temperature rating	correction factor for 40 °C
≤ 100A	60 °C	0.82
> 100A	75 °C	0.88

## 6.5 Voltless Contacts

The refrigerated dryer is provided with the following volt-free alarm contacts for connection to an external alarm reporting system:

- Message: "Motor running"
- Message: "High pressure dewpoint "

## Preparation For Initial Start Up

---

### 7 Preparation For Initial Start Up

#### 7.1 Points to be Observed before Start Up

Every refrigerated dryer is tested in the factory and carefully checked before shipment. The test run confirms that the refrigerated dryer conforms to the manufacturer's specifications and operates as designed. However, independent of the checks made at the factory, the refrigerated dryer could be damaged during transport. For this reason, we recommend that the refrigerated dryer be examined for any damage. Inspect the refrigerated dryer carefully during the first hours of operation for any possible malfunction.

**Attention!**

**The internal components of the refrigerated dryer are factory adjusted for correct operation. Adjustments may not be made to these components without prior written consultation with KAESER Compressors Inc.**

#### 7.2 Points to be Observed before Switching On:



**NON-OBSERVANCE OF THESE OR OTHER REFERENCES (WARNING; ATTENTION) CAN LEAD TO ACCIDENTS CAUSING INJURY TO PERSONNEL OR DAMAGE TO EQUIPMENT.**

**It is forbidden to operate the refrigeration dryer with the panelling removed because of the danger of injury to personnel.**

- ☞ Remove all packaging materials, tools and transport securing devices on and in the refrigerated dryer.
- It is expected that the user employs safe working techniques when operating the refrigeration dryer and that all valid operating and safety provisions are followed.
- The operator of this refrigerated dryer unit is responsible for its safe working condition.
- The air in the compressor space and the compressed air to be dried may not contain any acid-forming or other aggressive matter.
- Do not connect the refrigerated dryer to a supply voltage different to that shown on the nameplate.
- Install the refrigerated dryer in a space that is not subject to freezing conditions. See chapter 1.4 for the minimum ambient temperature.
- Wait for the refrigerated dryer to warm up to the ambient temperature before putting into operation.



**Carry out the following work only when the power supply is removed from the refrigerated dryer:**

**Check all screws on the electrical connections for tightness and tighten if necessary (carry out this check again after 50 operating hours).**



### 7.3 Ready for Operation

**Attention!**

**Do not start the refrigerated dryer until completing the following:**

- The refrigerated dryer is installed according to the conditions stated in chapter 6.
- All electrical connections, air piping and condensate lines are correctly connected and properly tightened.
- The shut-off valves in the compressed air inlet and outlet lines are closed.
- The condensate drainage line is free of obstructions.
- The refrigerated dryer is supplied with the correct voltage supply.
- The by-pass in the compressed air line between input and output lines is closed.

**Attention!**

**Start the refrigerated dryer for approximately 15 minutes before opening the shut-off valves in the compressed air inlet and outlet lines.**

## Operation

### 8 Operation

During operation of the refrigerated dryer, condensate is separated from the compressed air.



**The condensate must be drained and collected in a suitable container. It must be disposed of according to Federal and local environmental codes.**

☞ Collect the accumulated condensate in a container and dispose of properly.

#### 8.1 Instrument Panel

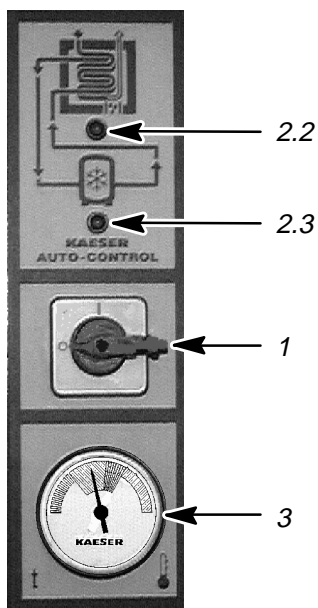

- 1 Main switch
- 2 KAESER-AUTO-CONTROL:
  - 2.2 "Control Voltage ON" and thermal mass effective
  - 2.3 "Refrigerant Compressor ON" indication
- 3 Pressure dewpoint gauge

## Operation

Explanation of the colored segment scale of the pressure dew point indication:  
(suction pressure gauge)

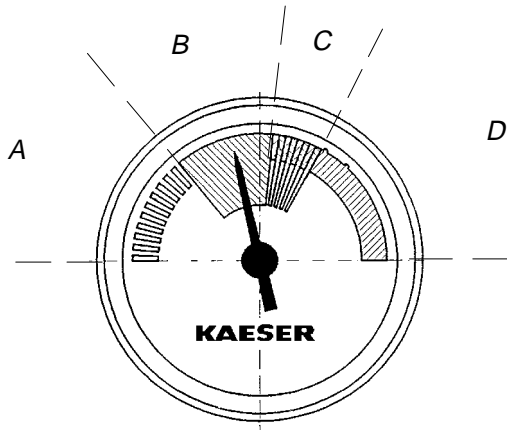

- **A**

**Blue–white range (low suction pressure) results in too low a pressure dewpoint due to:**

- Evaporator temperature too low (evaporator freeze–up)
- Dryer too large or very low air demand. Refer to chapter 1.4

- **B**

**Green range (normal suction pressure) results in a normal pressure dew point.**

- **C**

**Green–red range (elevated suction pressure) results in increased pressure dew point to:**

- High ambient temperature

- **D**

**Red range (high suction pressure) results in too high a pressure dew point due to:**

- Fault, see chapter 8.4.3 for help

## 8.2 Starting the Refrigerated Dryer

**Attention!**

Switch on the refrigerated dryer only if the conditions in chapter 7.3 “Ready for Operation” are fulfilled.

- ☞ Check the refrigerated dryer according to chapter 7.3.
- ☞ Remove the padlock provided for protection against “inadvertent switch–on” of switch (1).
- ☞ Rotate the switch (1) to “I” (ON).

The refrigeration dryer is now in operation, the control lamp (2.2) illuminates indicating power on.

Depending on the temperature in the air to refrigerant heat exchanger, the refrigerant compressor switches on after the refrigeration dryer is switched on. Simultaneously the control lamp (2.3) “Refrigerant Compressor ON” illuminates.

## Operation



If the control lamp (2.3) does not extinguish after approximately 15 minutes then a fault is apparent (see chapter 8.4.3).

**Attention!**

Do not open the compressed air shut-off devices (inlet/outlet) until the control lamp (2.3) is extinguished.

- ☞ Open the shut-off valve of the compressed air inlet slowly (admission of the compressed air).
- ☞ Open the shut-off valve of the compressed air outlet slowly.

The compressed air system is now connected to the refrigerated dryer.

**Attention!**

Press RESET if the safety pressure switch has shut down the refrigerated dryer.

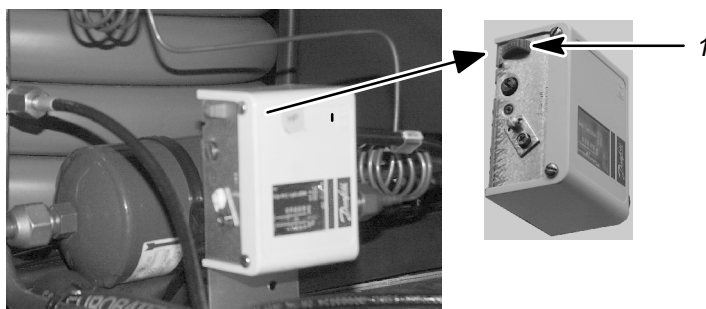
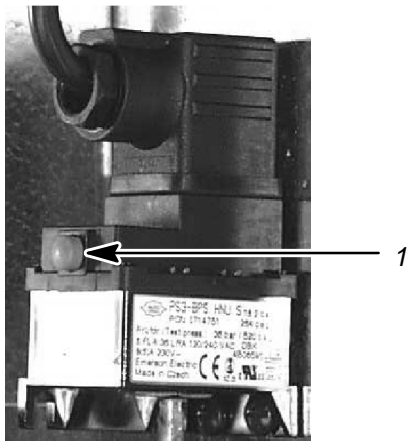

1 RESET

### 8.3 Stopping the Refrigerated Dryer

- ☞ Close the compressed air shut-off valves (inlet and outlet).

**Attention!**

The main switch (1) can be secured in the "0" position against inadvertent switch-on by a small padlock.

- ☞ Turn switch (1) to "0" (OFF).

The refrigerated dryer is switched off and the control lamp is off.

## 8.4 Trouble shooting



The local safety regulations (see chapter 2) and the regulations detailed in the "Safety" chapter must be complied with during trouble-shooting.

See chapter 7.3 and chapter 8.2. when starting the refrigerated dryer after the malfunction has been corrected.

### 8.4.1 Water in the compressed air system

#### Possible cause:

Moisture deposits in the compressed air pipe work that were formed before the dryer was started.

Bypass opened.

Compressed air inlet and outlet swapped.

The condensate is not drained out of the system.

#### Remedy:

Blow out the compressed air pipe work with dry air until no more moisture condenses.

Close the bypass.

Check the compressed air connections using the dimensional diagram.

Check the ECO-DRAIN (see chapter 9.2.4); Contact the authorized KAESER distributor.

### 8.4.2 High pressure losses via the refrigerated dryer

#### Possible cause:

Refrigerated dryer iced up on the air side.

#### Remedy:

Switch (1) to the "OFF" (0) position. until the air system has thawed. If the system ices up again after starting again, refer to authorized KAESER distributor.

### 8.4.3 Pressure dew point too high

#### Possible fault:

Ambient temperature too high.

Compressed air inlet temperature is too high.

Flow volume too high.

Low refrigerant.

Defective refrigerant compressor.

Defective condenser fan motor.

High contamination component in the compressed air causing scale in the compressed air system.

Condenser surface (refrigerant liquefier) contaminated.

#### Remedy:

Check the technical data, see chapter 1.2.

Check the technical data, see chapter 1.2.

Check the technical data, see chapter 1.2.

Refer to authorized KAESER distributor.

Refer to authorized KAESER distributor.

Refer to authorized KAESER distributor.

Clean the compressed air system.

See maintenance instructions chapter 9.2.2.

## 8.4.4 High compressed air losses

**Possible fault:**

Constant loss of pressure via the condensate drain.

**Remedy:**

Clean the ECO–DRAIN (see chapter 9.2.5).

## 8.4.5 Red LED on the ECO–DRAIN housing flashes

**Possible cause:**

Condensate not draining.

**Remedy:**

Check the ECO–DRAIN (see chapter 9.2.4); contact authorized KAESER distributor.

## 8.4.6 The safety pressure switch shuts down the refrigerated dryer

**Possible fault:**

Ambient temperature too high.

**Remedy:**

Check the technical data, see chapter 1.2.

Condenser surface (refrigerant liquefier) contaminated.

See maintenance instructions chapter 9.2.2.

Defective condenser fan motor.

Refer to authorized KAESER distributor.

# Maintenance

## 9 Maintenance

### 9.1 Maintenance Instructions:



Before starting work, follow the procedure below to ensure the unit is not started or energized while maintenance work is being performed:

Work on the electrical equipment of the refrigerated dryer may only be carried out by a qualified electrician or trained personnel under the supervision of a qualified electrician according to local codes.

Lock the main disconnect in the "off" position in accordance with applicable lock out/tag out procedures (example: OSHA CFR 29 § 1910.147) to ensure the dryer does not restart.

Before starting work, carry out the following procedure to prevent inadvertent application of power to the refrigerated dryer:

- ☞ turn switch (1) to " 0 ".
- ☞ lock out the switch (1) using a suitable padlock.

Before restarting the refrigerated dryer, ensure that:

- no maintenance personnel are working on the refrigerated dryer.
- all tools are removed from the refrigerated dryer.
- all guard and cover panels are properly installed and secured.

See chapter 7.3 and 8.2 for starting the refrigeration.

### 9.2 Regular Maintenance

Period	Work to be done	see chapter
Daily	Check the condensate outlet	9.2.3
50 hours after initial start	Clean the ECO–DRAIN	9.2.5
Every month	Check ECO–DRAIN for proper operation	9.2.4
	Clean the surface of the condenser	9.2.2
If necessary	Clean the ECO–DRAIN diaphragm valve	9.2.5
Every three month	General checks	9.2.1
Every year	Clean the ECO–DRAIN	9.2.5

The maintenance periods are recommended periods and may need to be adjusted based on installation and service conditions.

#### 9.2.1 General checks

- ☞ Inspect the electrical components of the refrigerated dryer every two to three months. Correct any malfunctioning or worn components, such as loose connections or over-heated cable immediately!

## Maintenance



**Escaping compressed air and/or refrigerant can cause injury to personnel and lead to damage to the dryer.**

- ☞ Check all pipework, hoses and screwed fittings for leakage every two to three months and carry out a visual check for any external damage. Correct any faults immediately!



**The refrigerant contained in the refrigerating system may not be vented to the open air. Always use a refrigerant recovery system when working on the refrigerant circulation. Dispose of unusable refrigerant according to environmental regulations!**

### 9.2.2 Cleaning the condenser

Clean the condenser every month.

- ☞ Stop the refrigerated dryer by turning the switch (1) to the “off” position.
- ☞ Lock the switch (1) with a suitable padlock to prevent unauthorized switch-on.
- ☞ Clean the cooling fins of the refrigerant liquefier by blowing compressed air from the outside to the inside.

See chapter 8.2 to start the refrigerated dryer.

### 9.2.3 Check the condensate outlet daily as follows:

**Attention!**

**If neither condensate nor compressed air exits, clean the ECO-DRAIN. (See chapter 9.2.5)**

- ☞ Verify that condensate exits from the hose of the condensate drain outlet when the drain opens (the LED extinguishes for a short period).

### 9.2.4 Check ECO-DRAIN for proper operation monthly, as follows:

Check the function of the condensate drain by pressing the TEST pushbutton on the upper housing of the ECO-DRAIN. The solenoid valve of the ECO-DRAIN opens when the TEST pushbutton is pressed.

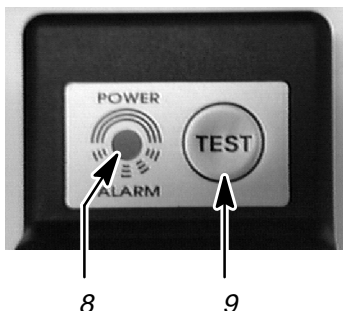

- 8 Operational status – light emitting diode
- 9 TEST pushbutton (condensate drain)

- ☞ Unscrew the two screws holding the left-hand side cover and remove the cover.
- ☞ Press the TEST pushbutton on the ECO-DRAIN housing.

Press the test pushbutton for at least 1 second. The valve will open every 2 to 3 seconds. The LED will flash to indicate the valve's opening and closing. Note that all accumulated condensate should drain.



## Maintenance

### Condensate does not drain:

- Outlet hose of the ECO-DRAIN is blocked.  
If necessary, clean or replace the outlet drain hose.
  - Diaphragm valve is clogged.  
See chapter 9.2.5.
  - Solenoid coil is defective.  
Contact authorized KAESER distributor.
- ☞ Screw on the left-hand side panel.

### 9.2.5 Cleaning the ECO-DRAIN

Clean the condensate drain monthly, or more frequently depending on the degree of contamination of the compressed air.

It is recommended that the ECO-DRAIN is cleaned after the first 50 hours of service.

Maintenance work on the ECO-DRAIN is only possible with the ECO-DRAIN removed.

#### Initial work:

- ☞ Stop the refrigerated dryer by turning the switch (1) to the "off" position.
- ☞ Lock the switch (1) with a suitable padlock to prevent unauthorized switch-on.
- ☞ Unscrew the two screws holding the left-hand side cover and remove the cover.



**Before removing up the ECO-DRAIN it must be shut off from the compressed air.**

- ☞ Close the shut-off valve in the air line to the ECO-DRAIN.

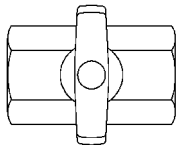

*Shut-off valve  
closed*

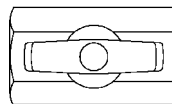

*Shut-off valve  
opened*

#### Removing the ECO-DRAIN:

- ☞ Depressurize the ECO-DRAIN by pressing the TEST pushbutton.
- ☞ Unscrew the screw fittings between the shut-off valve and the ECO-DRAIN.
- ☞ Take out the ECO-DRAIN.

**Attention!**

**The ECO-DRAIN is still connected to the power supply cable.**

## Maintenance

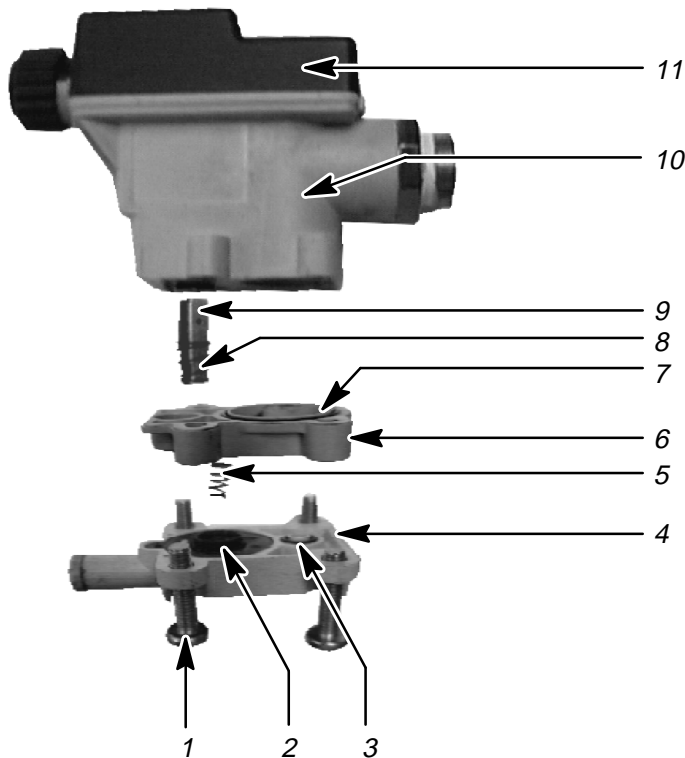

- |                               |                                  |
|-------------------------------|----------------------------------|
| 1 Cross-head screws, M5 x 2.5 | 7 O Ring, 28 x 1.5               |
| 2 Diaphragm                   | 8 Thrust spring for valve piston |
| 3 O Ring, 6 x 1.5             | 9 Valve piston                   |
| 4 Diaphragm seat              | 10 Housing                       |
| 5 Thrust spring for diaphragm | 11 Top cover                     |
| 6 Diaphragm cover             |                                  |

Items in ( ) refer to items detailed in the previous figures.

### Removal of the ECO-DRAIN:

**Attention!**

**Watch for loose parts fitted into each other that could easily be lost when disassembling the ECO-DRAIN. Note the final positions of the individual parts.**

- ☞ Unscrew the four cross-head screws (1) on the diaphragm seat (4) and remove carefully with the diaphragm cover (6) from the housing (10). Watch for loose parts, such as the pressure springs (5) and (8), diaphragm (2) and the O rings (3) and (7)!

### Cleaning:

- ☞ Remove the thrust spring (5), diaphragm (2) and valve piston (9) with its thrust spring (8) and clean them.



**Do not direct compressed air toward any person at any time. Compressed air is contained energy and as such, is dangerous to life.**

**Wear protective goggles when blowing out components.**

- ☞ Blow out the diaphragm seat (4), diaphragm cover (6), and the housing inside with compressed air.

## Reassembly of the ECO–DRAIN:

**Attention!**

**It is recommended that parts subject to wear, such as the diaphragm, valve piston and O rings are renewed for reasons of safety and reliability.**

- ☞ Check the diaphragm (2), the existence and correct seating of the O rings (3) and (7) on the diaphragm seat (4) and diaphragm cover (6). Renew defective parts.
- ☞ Check the valve piston (9) for signs of wear and renew, if necessary.
- ☞ Check the existence and correct seating of the thrust spring (8) for the valve piston (9).
- ☞ Insert the valve piston (9) into the guide hole in the housing.
- ☞ Place the thrust spring (5) over the nipple on the diaphragm cover (6). Check that the thrust spring (5) sits correctly.
- ☞ Fit and position the diaphragm cover (6) over the valve piston (9) in the housing.
- ☞ Fit the diaphragm (2) into the opening in the diaphragm seat (4).
- ☞ Fit the diaphragm seat (4) to the diaphragm cover (6). Check that the thrust spring (5) is positioned in the recess provided in the diaphragm (2). Insert the four cross–head screws (1) through the holes provided in the vertically assembled diaphragm seat, diaphragm cover and housing and screw the components together tightly.

### Final work:

- ☞ Fit the ECO–DRAIN back into the refrigeration dryer with the screw fittings.
- ☞ Open the shut–off valve (in the compressed air line to the ECO–DRAIN).
- ☞ Carry out a functional check of the ECO–DRAIN (see chapter 9.2.4).
- ☞ Screw on the left–hand side panel.

See chapter 8.2 to start the refrigerated dryer.

## 10 Spare Parts and After Sales Service

Provide the following details for all queries and spare parts orders:  
(see also the name plate)

Refrigerated dryer, model: .....

Serial number: .....

Part name: .....

Part order number: .....

Always provide the date of initial start up when making claims under warranty!

### Name plate:

	Typ./Model./Type/Tipo/ Modelo/Type
	Artikel-Nr./Part-No./ Référéncja/Codice/ Artículo-N.º / Artikel-Nr.
	Baujahr/Year/Année de fabrication/Anno/Año de construcción/Bouwjaar
	Serien-Nr./Serial No./ No. de série/N. di Matricola/ Nº de Matricula/Serienr.
Kältesystem/Refrigerant system/Système frigorifique/ Circuito refrigerante/Circuito frigorífico/Koelstelsysteem	Kältemittel/Refrigerant/Système frigori- fique/Agente refrigerante/ Agente frigorífico/Koelmiddel
	Füllgewicht/Charge/Charge/ Carga/Peso de relleno/ Vulgewicht <span style="float:right">lb.</span>
	Betriebsdruck HD/Working pressure HP/ Pression de fonctionnement HP/Pressione AP/ Presión de trabajo AP/Bedrijfsdruk HD <span style="float:right">psig</span>
Luftsysteem/Air system/ Système d'air/Circuito aria/ Circuito de aire/Luftsysteem	Betriebsdruck/Working pressure/Pression de fonctionnement/Pressione di esercizio/ Presión de trabajo/Bedrijfsdruk <span style="float:right">psig</span>
	E-Anschluß/Electrical supply/ Alimentation électrique/ Alimentazione elettrica/ Alimentación eléctrica/ Elektrische aansluiting
	Nennspannung/Rated voltage/Tension nominale/tensione nominale/ Tensión nominal/Nominale spanning <span style="float:right">V</span> <input type="checkbox"/> 1ph <input type="checkbox"/> 3ph
	Frequenz/Frequency/ Fréquence/Frequenza/ Frecuencia/Frequentie <span style="float:right">Hz</span>
	Nennstrom/Rated current/Courant nominal/Corrente nominale/Corriente nominal/Nominale stroom <span style="float:right">A</span>
Umgebungstemperatur/Ambient temperature/ Température ambiante/temperatura ambiente/tem- peratura ambiente/Omgevingstemperatuur <span style="float:right">min. 40 °F / max. 110 °F</span>	
Dichtheit geprüft/Leakproof/Etanchéité testée/Ermetico/Hermético/Dichtheid getest <input type="checkbox"/>	

## Appendix

---

### 11 Appendix

#### 11.1 Wiring Diagram

Wiring Diagram  
air dryer TD 76

575V 3Ø 60CY

manufacturer: KAESER COMPRESSORS  
96450 COBURG  
GERMANY

consignee:

customer:

a			date	07.08.2000	<b>KAESER</b> COMPRESSORS	cover page air dryer TD 76	DTD76 - U0909.00	
b			editor	Sitter			Page	1
c			check	Gegner				
A	modification	date	name					

1 Input voltage  
575V Ø3 60CY

2

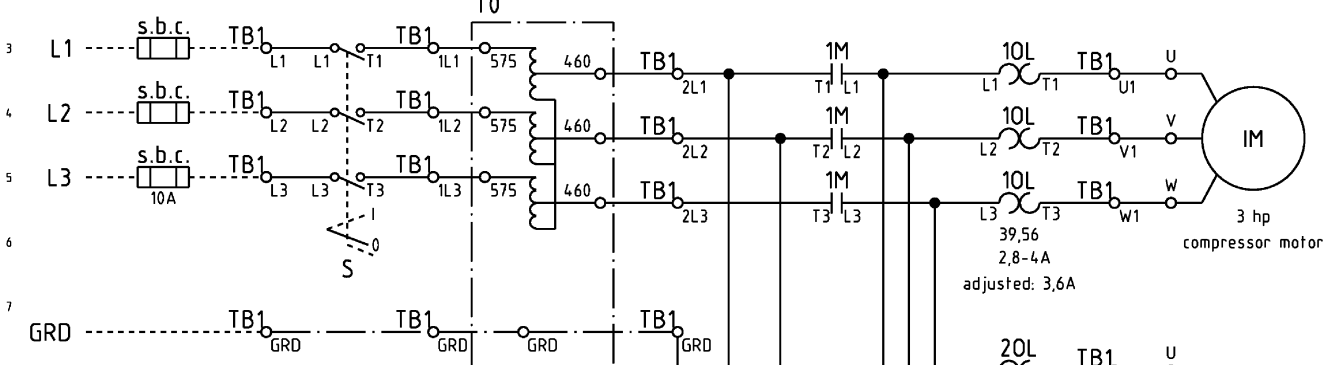

supply line cross-section and fusing see service manual

s.b.c. = supplied by customer

3 hp compressor motor

0,2 hp vent motor

39,56  
2,8-4A  
adjusted: 3,6A

39,57  
0,4-0,63A  
adjusted: 0,5A

1FU 0,5A

2FU 0,5A

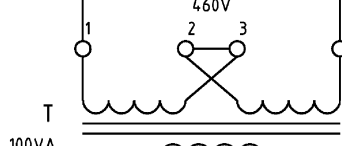

Secondary side is ground.  
\* While extracting the connecting cable control of insulation is required.

3FU 1A

-G2  
32

-TB102  
32

a			date	07.08.2000
b			editor	Sitter
c			check	Gegner
d	modification	date	name	

**KAESER**  
COMPRESSORS

wiring diagram  
compressor TD 76

STD76 - U0909.00

Page 1

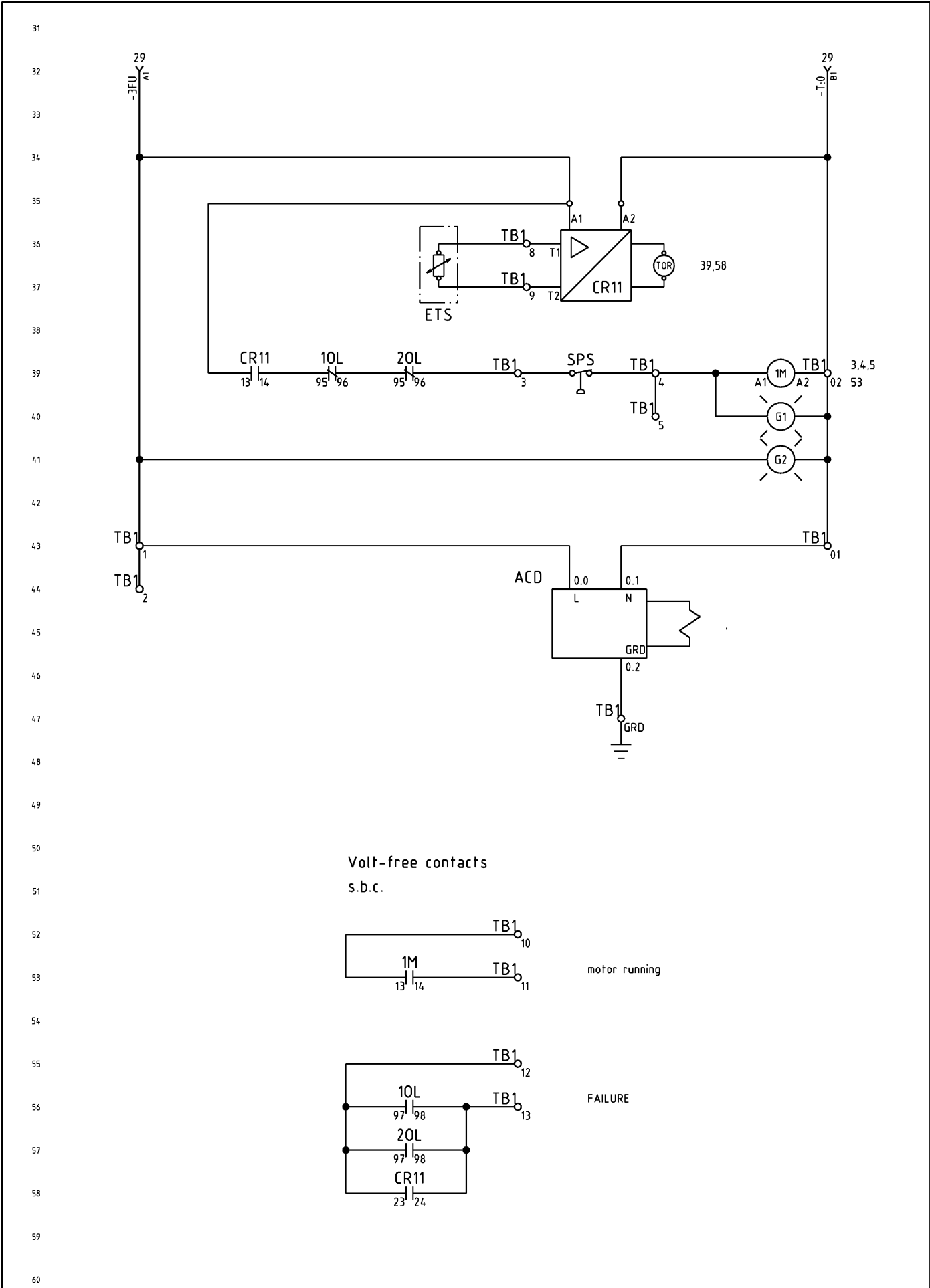

Volt-free contacts  
s.b.c.

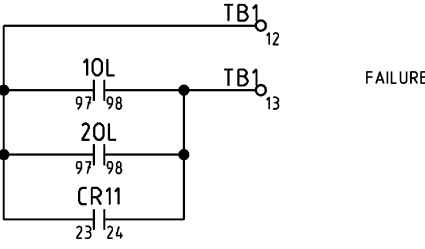
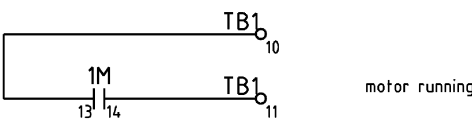

a			date	07.08.2000	<b>KAESER</b> COMPRESSORS	wiring diagram air dryer TD 76	STD76 - U0909.00	
b			editor	Sitter			Page 2	
c			check	Gegner				
D	modification	date	name					



SPS safety pressure switch  
 ETS NTC-temperature probe  
 1FU,2FU,3FU control fuse  
 CR11 NTC-thermostat  
 1M motor starter  
 IM compressor motor with overload protection  
 IIM vent motor  
 S switch ON/OFF  
 TB1 terminal strip  
 G1 indicating light "motor running"  
 G2 indicating light "power on"  
 ACD Automatic condensate drain  
 T transformer  
 T0 auto-transformer  
 10L,20L overload relay

a			date	07.08.2000	<b>KAESER</b> COMPRESSORS	component legend air dryer TD 76	STD76 - U0909.00	
b		editor	Sitter					
c		check	Gegner					
d	modification	date	name				Page	3

A	B	C	D	E
Qty.	Description and function	Component identification data	Order No.	Component
1	controller	CKC	7.4697.0	
1	motor starter	A9-30-10-89	ABB	7.5750.00010 -1M
1	overload relay	TA25 DU4 2,8-4A	ABB	7.5772.0 -10L
1	overload relay	TA25 DU0,63 0,4-0,63A	ABB	7.5769.0 -20L
2	adapter	DB25/25	ABB	7.5763.0 -10L,-20L
1	transformer	2x230/115V 100VA	Block	7.2220.1 -T
1	fuse socket	USM 3 3pol.	Gould	7.3320.00010 -1FU,-2FU,-3FU
2	primary control fuse for 460V	ATQ 0,5 0,5A	Gould	7.3310.0 -1FU,-2FU
1	secondary control fuse	TRM 1 1,0A	Gould	7.3300.0 -3FU
1	NTC-thermostat	TRN 122K-3-9 115V 60Cy	Ziehl	7.4690.10040 -CR11
1	terminal strip		Wieland	7.3165.10030 -TB1
6	series terminal	WK 2,5/U	Wieland	7.3948.0 -TB1
2	GRD terminal	WK 4SL/U	Wieland	7.3949.0 -TB1
	operating panel			
1	main switch/Emergency Stop	KG20A 3-pole	Solenoid	890939.0 -S
2	LED indicator	130V green	EBT	7.5720.0 -G1,-G2
1	auto-transformer external	3x575/3x460V	Block	7.5452.00050 -T0

When ordering spare parts include all the information in columns B, C and D and nameplate of compressor



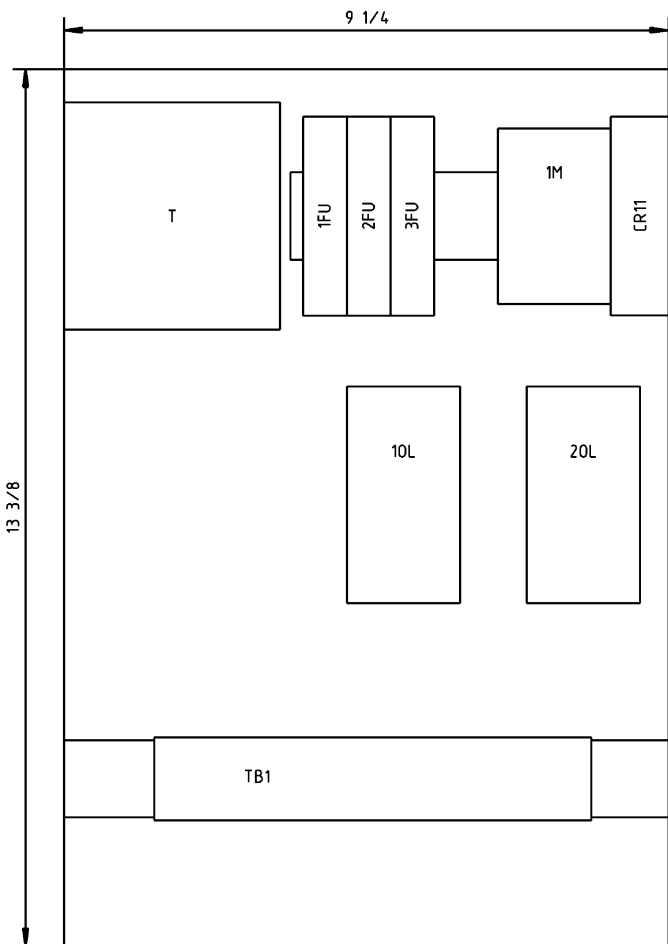

a			date	07.08.2000
b			editor	Sitter
c			check	Gegner
D	modification	date	name	

**KAESER**  
COMPRESSORS

electrical component parts list  
air dryer TD 76  
control panel

ATD76 - U0909.00

