

SERVICE MANUAL

USE

Rotary Blower Package

Model: DB 130 C pr

Article No.: 882273.00950 – V01

Serial No.:

Table of Contents



Chapter - Page

1	Technical Specification	1 - 1
1.1	Rotary Blower Package	1 - 1
1.2	Sound Pressure Level, Sound Power Level	1 - 1
1.3	Electrical Connection	1 - 1
1.4	Lubricant Capacities	1 - 2
1.5	Lubricant Oil Filling	1 - 2
1.6	Recommended Lubricants	1 - 2
1.7	Designation	1 - 3
1.8	Installation Requirements	1 - 3
1.9	Dimensional Diagrams	1 - 3
1.10	Design Data (Diagrams)	1 - 4
2	Safety Regulations	2 - 5
2.1	Explanations of Symbols and References	2 - 5
2.2	General Notes on Accident Prevention Regulations	2 - 5
2.3	Accident Prevention Regulations	2 - 6
2.4	General References	2 - 6
2.5	Spare Parts	2 - 7
3	General	3 - 8
3.1	Correct Use	3 - 8
3.2	Copyright	3 - 8
4	Transport	4 - 9
4.1	Transport Instructions	4 - 9
4.2	Packaging	4 - 10
4.3	Temporary Storage	4 - 11
5	Construction and Principles	5 - 12
5.1	Principle of Compression	5 - 12
5.2	Short Description	5 - 12
6	Installation	6 - 13
6.1	Installation Requirements	6 - 13
6.2	Compressed air Connection	6 - 13
6.3	Electrical Connection	6 - 13
6.4	Lubricant Oil Filling	6 - 14
7	Putting into Operation	7 - 15
7.1	Points to be Observed	7 - 15
7.2	Starting Precautions	7 - 15
7.3	Direction of Rotation Check	7 - 16

Table of Contents



Chapter - Page

8	Operation	8 - 17
8.1	Starting and Stopping the Package	8 - 17
8.2	Action to be taken during a Fault	8 - 17
8.2.1	Abnormal running noises	8 - 17
8.2.2	Excessive blower temperature	8 - 18
8.2.3	Oil leaking into air chamber	8 - 18
8.2.4	Low inlet volume flow	8 - 18
9	Maintenance	9 - 19
9.1	Precautions to be Observed during Maintenance and Servicing	9 - 19
9.2	Regular Maintenance	9 - 19
9.3	Checking Drive Belt Tension	9 - 20
9.4	Changing the Drive Belts	9 - 20
9.5	Lubricating Oil Level Check and Top-Up	9 - 21
9.6	Lubricating Oil Change	9 - 21
9.7	Cleaning the Blower Package	9 - 22
9.8	Air filter changing	9 - 22
9.9	Greasing the Electric Motor	9 - 22
10	Spare Parts and After Sales Service	10 - 23
11	Appendix	11 - 24
11.1	Instructions on Electrical Connection	11 - 24
11.2	Maintenance Schedule	11 - 25
11.3	Safety information concerning contamination of compressors, blowers, vacuum pumps and components	11 - 26

1 Technical Specification

1.1 Rotary Blower Package

Air flow capacity at maximum pressure difference.....	284	ICFM
Maximum rotary blower performance.....	13.3	BHP
Rotary blower speed	3505	rpm
Inlet pressure.....	14.7	psia
Outlet pressure.....	22.8	psia
Maximum pressure difference.....	8.1	psi
Temperature difference Δt	97	°F
Weight.....	926	lbf
Weight with sound enclosure	1367	lbf

The safety valve, supplied with the unit, starts to blow off at the maximum permissible discharge pressure in order to protect the rotary blower package.

The data for special applications are to be found in the design data (diagrams).

1.2 Sound Pressure Level, Sound Power Level

Operational state of the rotary blower package:

Full load, the rotary blower package runs at: rated speed, outlet pressure, max. air flow capacity

Measurement conditions:

free field measurement

Measurement to CAGI/PNEUROP PN8 NTC 2.3:

Sound pressure level.....	83	dB (A)
Sound pressure level with sound enclosure.....	< 67	dB (A)
Sound power level.....	98	dB (A)
Sound power level with sound enclosure	< 83	dB (A)

1.3 Electrical Connection

Electric motor:

Rated power	15	HP
Rated speed	3550	rpm
Specification	IP 55	
Power supply	575	V 3 Ph
Frequency	60	Hz
Maximum rated current IR.....	14.9	A

D-U-switch

Maximum mains fuse capacity (slowblow or class gl).....	25	A
---	----	---

V-belt set:

Description XPZ 1450

Article No.: 893152.0

Sound enclosure fan motor:

See the fan electrical diagram in the attachment under "Installation Instructions".

1.4 Lubricant Capacities

Drive end 8.5 ± 15 % Oz.

Gear end 10.1 ± 15 % Oz.

1.5 Lubricant Oil Filling

Attention!

The rotary blower package is delivered with a full charge of lubricating oil.

Type of oil used: KAESER OMEGA FLUID-M 220

1.6 Recommended Lubricants

The use of mineral oils with high ageing resistance, high viscosity index, good oxidation stability and good demulsifying properties are recommended. They should comply with the minimum requirements placed on mineral oil type C by DIN 51517, Part 1.

The following oils should be used taking ambient temperatures and the resulting oil temperatures into account:

- Ambient temperature 5 °F to 105 °F - normal oil temperature 25 °F to 176 °F
Lube oil type C, CL, CLP 100 to DIN 51517
Viscosity at 105 °F 100 ± 10 mm²/s (CSA)
ISO – VG 100

Recommended sort: KAESER OMEGA FLUID - M 100 part no.: 892475.0
in 1 litre bottle part no.: 885891.00010
in 5 litre canister part no.: 885891.0

- Ambient temperature 25 °F to 140 °F - higher oil temperature 35 °F to 230 °F
Lube oil type C, CL, CLP 220 to DIN 51517
Viscosity at 105 °F 220 ± 22 mm²/s (CSA)
ISO – VG 220

Recommended sort: KAESER OMEGA FLUID - M 220 part no.: 892338.0
in 1 litre bottle part no.: 883816.00010
in 5 litre canister part no.: 883816.0

For extreme operational conditions

- Ambient temperature –10 °F to 105 °F – oil temperature –10 °F to 230 °F
Lube oil type PG 150 DIN 51502
Viscosity at 105 °F 138 mm²/s (CSA)

Recommended sort: KAESER OMEGA FLUID - S 150 part no.: 892193.0
in 1 litre bottle part no.: 863289.00010
in 5 litre canister part no.: 863289.0

- If temperatures above 230 °F are expected
Lube oil type PG 220
Viscosity at 105 °F 214 mm²/s (CSA)

Recommended sort: KAESER OMEGA FLUID - S 220 part no.: 891356.0
in 1 litre bottle part no.: 883816.00030
in 5 litre canister part no.: 883816.00020

Other types of oil available on request

Note: Higher oil temperatures can occur if:

- the ambient temperature is above 105 °F
- the blower is within a sound enclosure
- the blower is pressure operated with pressure differentials above 8.7 psi.
- the blower is vacuum operated with pressure differentials above 4.35 psi.

1.7 Designation

The nameplate of the package is located on the frame.
(see chapter 10 for nameplate illustration)

1.8 Installation Requirements

Minimum ambient temperature - 15 °C

Maximum ambient temperature + 40 °C

Install in a machine space or similar surroundings

1.9 Dimensional Diagrams

(see following page)

Entwicklungsbedingte Änderungen vorbehalten. Zeichnung darf nur über CAD geändert werden.

Die Zeichnung bleibt unser ausschließliches Eigentum. Sie wird nur zu dem vereinbarten Zweck anvertraut und darf zu keinem anderen Zweck verwendet werden. Kopien oder sonstige Vervielfältigungen einschließlich Speicherung, Verarbeitung oder Verbreitung unter Verwendungs elektronischer Systeme dürfen nur zu dem vereinbarten Zweck angefertigt werden. Weder Original noch Vervielfältigungen dürfen Dritten ausleihend oder in sonstiger Weise zugänglich gemacht werden.

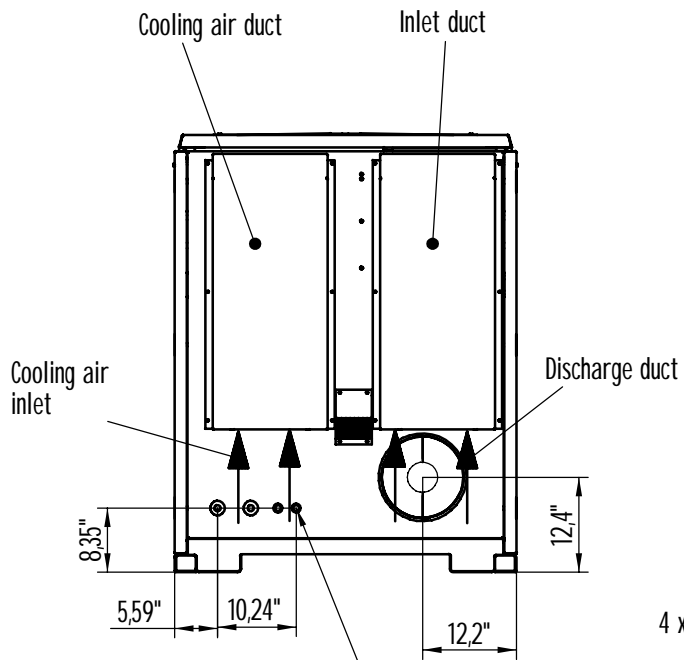

Cable leadthrough
2x grommets \varnothing 1,49"
2x grommets \varnothing 0,83"

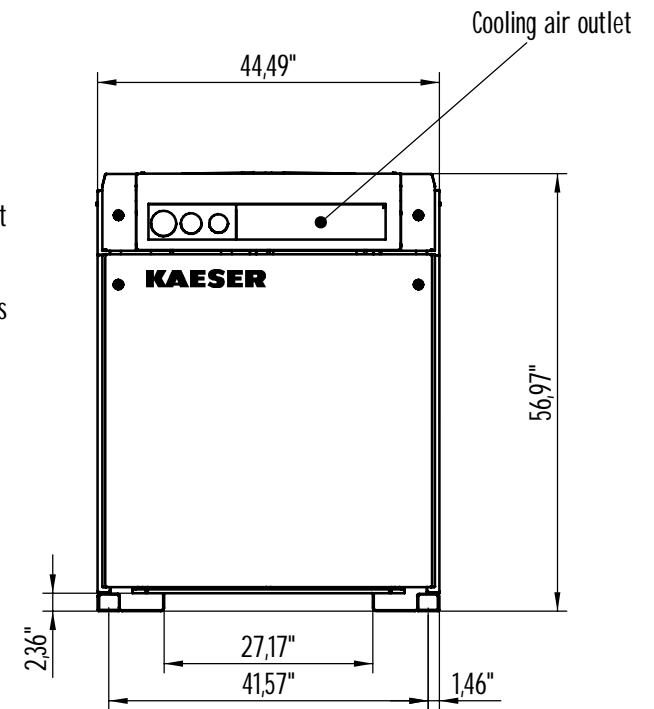
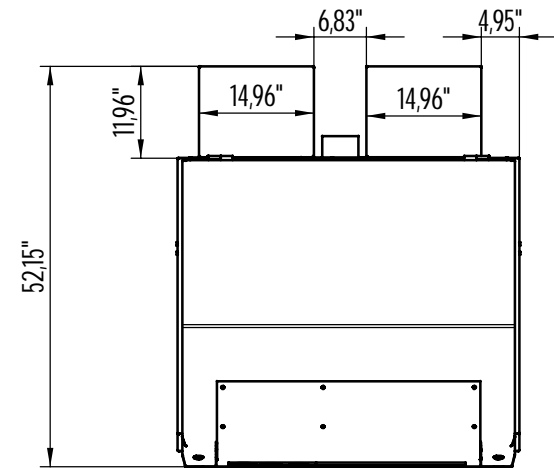
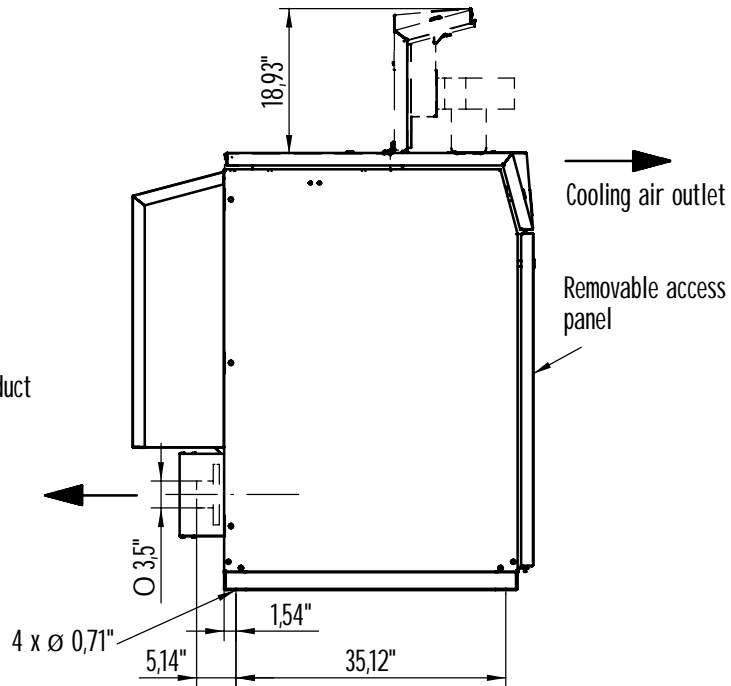

DB 130 C pr

Stand:	Datum:	Name:	CAD-Datei:
28.06.02	28.06.02	Lummer	MB001615.dft

KAESER
KOMPRESSOREN
— Werk Gera —

1.10 Design Data (Diagrams)

Air delivery in pressure operation

Blower shaft power in pressure operation

Temperature increase in pressure operation

pressure performance
inlet: air at 14.7 psia and 68 °F

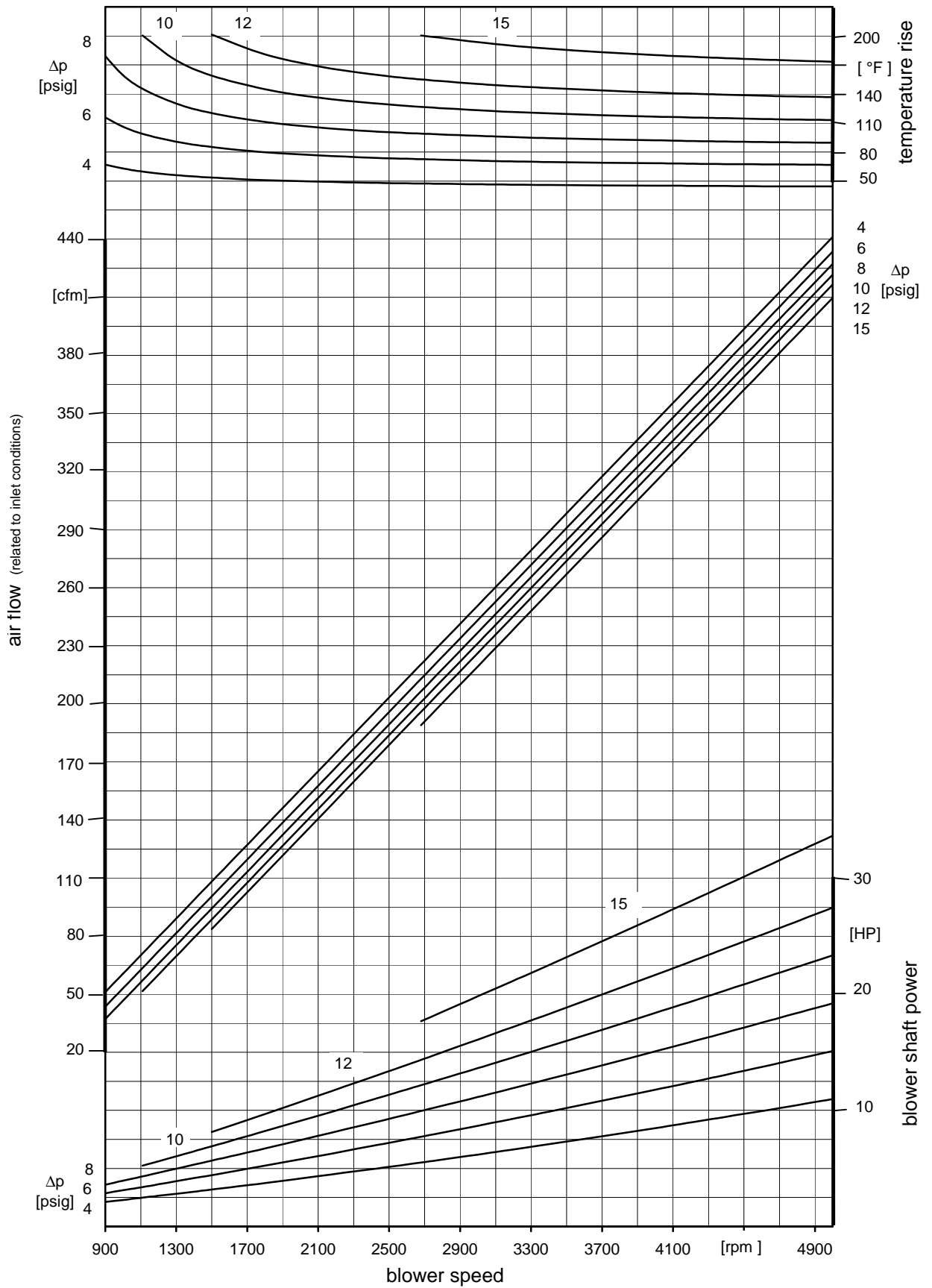

2 Safety Regulations

Read this Service Manual carefully and observe all cautionary references before putting the rotary blower package into operation and before carrying out any maintenance.

2.1 Explanation of Symbols and References



This symbol is placed before all references to safety where danger to life and limb can occur during work. It is especially important that these instructions are observed and that extreme care is taken. For their own protection inform all other users of these safety regulations. Observe general safety and accident prevention regulations as well as the safety instructions laid down in this manual.

Attention!

This symbol is placed at points where considerable attention should be paid to recommendations, instructions, references and correct sequences so that damage or destruction of the blower package and/or other equipment is prevented.



This symbol identifies environmental protection measures.



This symbol indicates operations to be carried out by the service technician or the operator.



This bullet indicates listings.

Explanation of the filter maintenance pictogram:

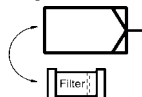

Note on the location of the inlet filter and the carrying out of filter maintenance.

Explanation of the warning notice on the rotary blower:



Warning:
Hot surface, do not touch.

Abbreviations:

VBG Association of Employers Liability Insurers (AELI)

UVV Accident Prevention Regulations (APR)

2.2 General Notes on Accident Prevention Regulations

The terms "UVV" and "VBG" are abbreviations and refer to specific accident prevention regulations of the Federal Republic of Germany.

Should any one of the regulations referred to in this service manual not conform to local accident prevention legislation then the stricter regulation applies.

Users of blower packages outside the Federal Republic of Germany are therefore obligated to check the valid accident prevention legislation concerning the blower package in the country of use. If legislation is precedent to German legislation, corresponding measures must be taken before the package is put into operation.

2.3 Accident Prevention Regulations

Accident prevention regulation 10.0 "Power Driven Work Units" (VBG 5)

Attention!

According to Accident Prevention Regulation VBG 5, Par. 12, the user of a rotary blower package is obligated to carry out the following measures (DIN VDE 0113 Part 1 and European Standards ES 60204-1 serve as appropriate instructions):

Rotary Blower Packages fitted with a drive motor of power exceeding 2.68 h.p. and drawing currents of more than 16 amps must be fitted with a lockable isolating switch (DIN VDE 0660, DIN VDE 0100) and fuses in the power supply to the blower package.

Details concerning the size of the isolating switch and the fuses are given in chapter 1.3.

Accident prevention regulation 13.4 "Compressors" (VBG 16)

Attention!

We refer especially to paragraph 12: General Installation and Condition of the Installation Space.

Accident prevention regulation 1.2 "Noise" (VBG 121)

Attention!

We refer especially to paragraph 10: Noise Protection for Personnel.

We also recommend observation of the following recommendations:

- No open flames and flying sparks at the place of installation.
- Ensure that sparks or high temperatures cannot cause fire or explosion during any necessary welding work on the package.
- Operating personnel must be instructed on the necessity of wearing ear muffs during operation of the package, especially during operation without the sound enclosure.
- Personnel should not linger for long periods in the direct vicinity of packages with damaging sound levels.
- Rotary blower packages may not be used for explosive, toxic, corrosive or damaging gases.
- Because of the high temperatures (up to 302 °F) do not touch the air pipes during blower package operation. Wait until the blower has cooled down and pressure has vented before attempting any repairs to the pipework.
- Use only the lubricants recommended by the manufacturer.

2.4 General References



Only trained or specialised personnel may work on power driven systems (see UVV 10.0).

Before work is carried out on electrical systems, carry out the following precautions in the sequence shown:

1. Switch off all phases
2. Ensure that the blower package is isolated and locked out
3. Check that no voltages are present

Vent or shut off the pipework if not otherwise stated in the service manual.

Attention!

The warranty is invalidated if any modifications are carried out without previous consultation and the consent of KAESER COMPRESSORS.

2.5 Spare Parts

Safe and reliable operation of the package is only guaranteed with the use of KAESER original spare parts.

3 General

Attention!

This Service Manual must always be available at the place of installation of package.

3.1 Correct Use

The package is intended solely for the transport of oil-free air under pressure and in conformity with the technical specification (see chapter 1.1).

Any other use is considered incorrect. The manufacturer cannot accept liability for any damage caused by incorrect use. The user alone is liable for any risks incurred. Correct use also means compliance with installation, removal, commissioning, operational and maintenance instructions laid down by the manufacturer.

3.2 Copyright

The copyright of this service manual is the property of KAESER Kompressoren GmbH: This service manual is intended for operating, maintenance and supervisory personnel use only. It contains instructions and technical diagrams that may not be copied, either completely or partly, distributed or evaluated by unauthorised persons for competitive purposes or divulged to any third party.

Transport

4 Transport

4.1 Transport Instructions

Attention!

To avoid damage to components of the package, we recommend the use of a fork lift truck, lift truck or a sling for transport.

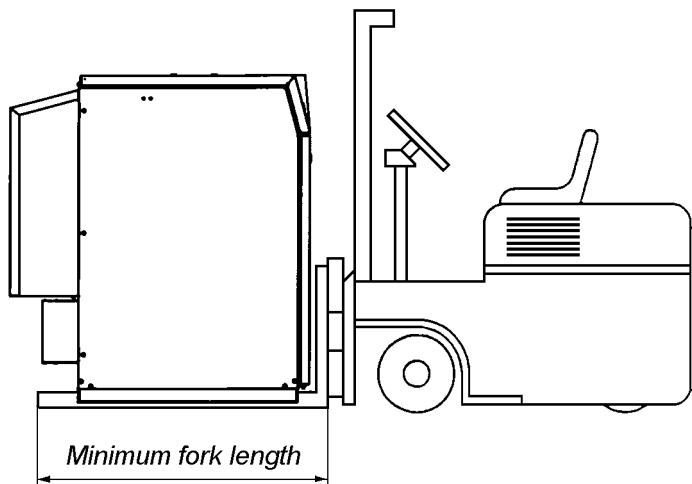

with sound enclosure

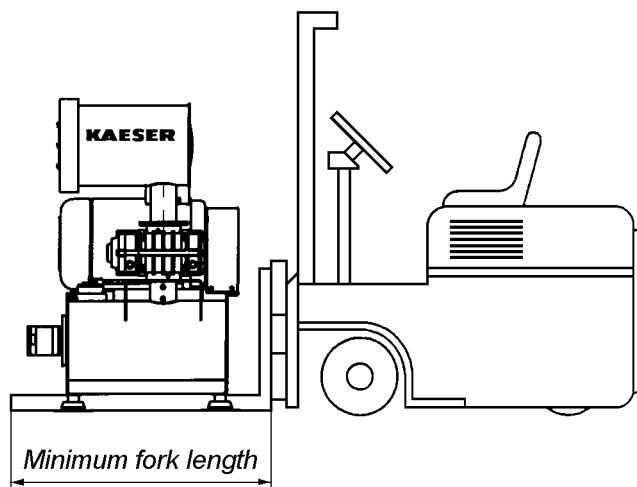

without sound enclosure

Attention!

When transporting using a crane hook, a suitable sisal or steel sling must be used (VBG 9a).

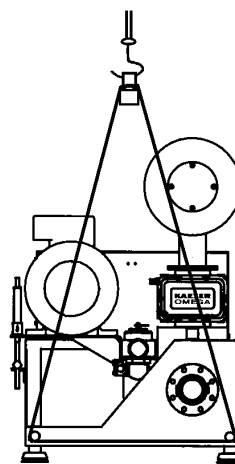
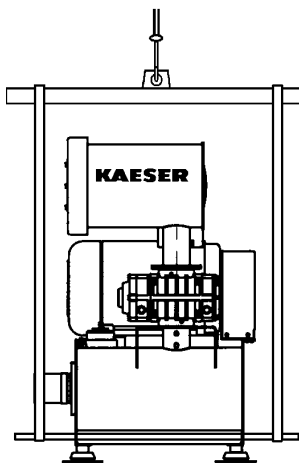
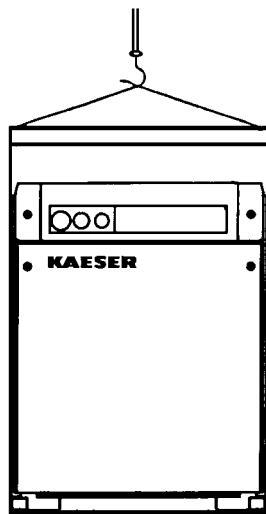

No side forces should act upon the package when transporting with a sling. Always use a spreader !

☞ To hang the rotary blower package, the sling bands must be fixed to the frame with a round bar of and padded, if necessary.

Avoid sudden, sharp vertical movements when lifting, lowering and transporting the rotary blower package.

4.2 Packaging

A decisive factor concerning the type of packaging is the transport route.

The packaging conforms to the packaging regulations laid down by the German Federal Association of Wood, Pallet and Export Packaging (HPE) and by the Association of German Mechanical Engineering Institutes (VDMA), if not otherwise contractually agreed.



Packaging should be recycled if possible or disposed of in an environmentally acceptable way.

4.3 Temporary Storage

Attention!

The package must be stored in a dry room at a constant temperature over 0°. Air inlet and air outlet openings should be closed off to prevent ingress of dirt.

When storage is to be longer than a year the block should be treated with a preserving oil.

- ☞ Spray preserving oil onto the flanged ports, drive shaft and air chamber to protect against corrosion.
- ☞ Carry out an oil change annually (see chapter 9.6).

Recommended preserving oil:

External:

ESSO RUST BAN 324
MOBIL OIL TECREX 39
SHELL V-Product 9703

Internal:

AVIA Avilub MK 2000
ESSO LUB MZ 20 W/20
MOBIL Mobilarma 523 or 524
SHELL Ensis Motor Oil 20

or similar makes.

Putting into operation after a long period of temporary storage:

- ☞ Remove the preserving material from the air chamber with a suitable solvent.
- ☞ Carry out the measures detailed for installation and putting into operation.
- ☞ Carry out an oil change (see chapter 9.6).

5 Construction and Principles

5.1 Compression

The package is fitted with a KAESER blower block with OMEGA profiled rotors. Two rotors, synchronised by a pair of timing gears, rotate in opposite directions in two cylindrical bores within a casing. A defined quantity of air entering the inlet port is trapped between the lobes of the rotors and the casing and carried round to the discharge port. Because there is no contact between the rotors and the housing there is no wear and no lubrication is required.

KAESER rotary blowers consume only as much power as is demanded by the back pressure existing at the discharge port.

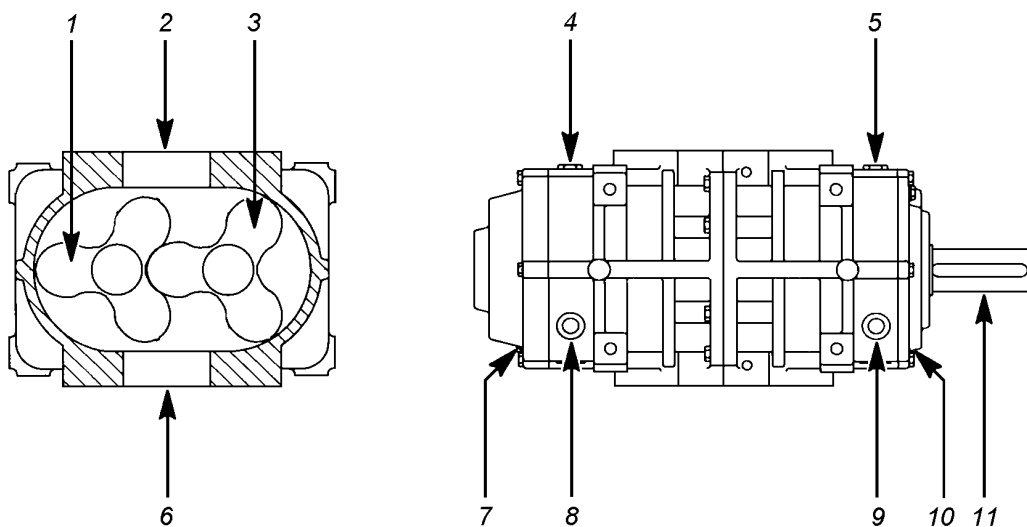

- 1 Male rotor
- 2 Inlet port
- 3 Female rotor
- 4 Oil filler plug, gear end
- 5 Oil filler plug, drive end
- 6 Discharge port

- 7 Oil drain, gear end
- 8 Oil level sight glass, gear end
- 9 Oil level sight glass, drive end
- 10 Oil drain, drive end
- 11 Drive shaft

5.2 Short Description

The rotary blower block is belt driven from an electric motor.

The electric motor and the blower are mounted on a common base frame.

The flow medium is drawn into the block via an inlet silencer in which an inlet filter is integrated.

The air flows in a vertical direction in the discharge silencer.

The compressed air is discharged at the connecting flange of the discharge silencer.

Installation

6 Installation

6.1 Installation Requirements

The package must be installed in a space of sufficient size allowing free access from all sides for maintenance and repair.

Sufficient air ventilation and exhaust conditions must be provided.

A special foundation or base is not required for installation.

Safe and reliable operation of the package is guaranteed only when the temperature limits laid down in chapter 1.8 are complied with.

6.2 Compressed Air Connection

The blower package is delivered ready for operation up to and including the compressed air discharge connection.

The discharge connection downstream to the pipework or user should be made via a flexible connecting sleeve, preferably a rubber sleeve.

Attention!

During installation of the package the regulations laid down in UVV 13.4 must be observed.

It is especially important that necessary safety devices, a check plate and operational measuring and control devices are provided.

If the air flows into a system which remains pressurised after switching off the blower package, an off-load starting valve or similar device must be fitted.

To ensure safe and reliable operation of the blower package it is recommended that at least the following parameters are monitored and interlocked with the drive:

- Discharge pressure or pressure difference Δp
- Discharge temperature
- Electrical current drawn

6.3 Electrical Connection



The main power supply connection and installed protective measures must be carried out by an authorised specialist according to DIN VDE regulations and the regulations of the electrical supply authority concerned.

Attention!

According to Accident Prevention Regulation VBG 5, Par. 12, the user of a rotary blower package is obligated to carry out the following precautionary measures (DIN VDE 0113 Part 1 and European Standards ES 60204-1 serve as appropriate instructions):

Rotary Blower Packages fitted with a drive motor of power exceeding 2.68 h.p. and drawing currents of more than 16 Amps must be fitted with a lockable isolating switch (DIN VDE 0660, DIN VDE 0100) and fuses in the power supply to the blower package.

Attention!

The size of the main isolating switch (to AC 23, category of use) is dependent on the maximum rated current I_N (see chapter 1.3).

Recommendations for the size of the cable core cross-sections and the fuses are detailed in chapter 1.3.

The cross-sections of the supply cable and the fuses are installed to DIN VDE 0100, Part 430 and 523 for an ambient temperature of 86 °F. Under other operational conditions, e.g. higher ambient temperatures or longer power supply cables (over 197") the supply cable cross-sections and fuses must be checked according to DIN VDE regulations and the regulations of the electrical supply authority concerned.

7 Putting into Operation

7.1 Points to be Observed

Every rotary blower package is given a test run in the factory and carefully checked before shipment. The test run confirms that the package conforms to the specification data and runs perfectly. However, it is recommended that it is inspected for damage that could have occurred during transport. The package should be carefully observed during the first hours of operation to determine any malfunction that could occur.

The user is responsible for the installation of the complete package.

- Before putting into operation check the correct sequence of the compulsory safety and monitoring devices and the necessary operational measuring and control devices for the processing technology used.
- Check the installation of check plate, valves and controls for correct direction.
- Remove the blanking caps fitted during installation.

7.2 Starting Precautions



ANY NON-OBSERVANCE OF THESE OR OTHER PRECAUTIONARY REFERENCES (WARNING, ATTENTION) COULD LEAD TO AN ACCIDENT CAUSING INJURY TO PERSONNEL OR DAMAGE TO EQUIPMENT.

- ☞ Remove all packaging materials, tools and transport safety devices.
- It is expected that the user employs safe working methods and complies with all valid local operating and safety regulations when operating the package.
- It is the responsibility of the user to ensure that the package is constantly kept in a state of operational safety.
- Do not operate the package in spaces in which high dust pollution, toxic or inflammable vapours and gases can form.
- Do not connect the package to a different power supply than that stated on the motor nameplate.
- Install the package in a frost-free space and where the ambient temperature conditions (see chapter 1.8) are met.
- ☞ Check the drive shaft for ease of rotation by turning with the hand.
- ☞ Check the tension of the belt drive (see chapter 9.3).
- ☞ Check the oil level and top up if necessary (see chapter 9.5).



Remove all electrical power from the blower package before carrying out this work.

Lock out the supplies to the blower package to prevent accidental switch-on.

7.3 Direction of Rotation Check



Danger from rotating parts

- The rotors **must** rotate in the correct direction.
- The correct direction of rotation is counter-clockwise when looking at the end of the shaft. An arrow indicating the direction of rotation is located on the belt guard and on the blower block.
- ☞ Check the direction by turning the control switch to "I" and then immediately back to "O" again and observing the direction of rotation.
- ☞ If the direction is incorrect, the phase sequence in the power supply must be changed.

Attention!

If the blower block rotates in the wrong direction a reversal of the direction of flow and an evacuation of the discharge pipework occurs.

Always check the direction of rotation with the discharge line disconnected because the blower block could be damaged or destroyed should if foreign bodies are sucked in or a high vacuum is generated.

8 Operation

8.1 Starting and Stopping the Blower Package



Observe the safety regulations when putting the package into operation.

The starting and stopping procedure depends largely on the application at hand together with the control devices fitted.

Always start with the blower stationary. If back pressure is apparent in the pipework system then suitable measures ensuring off-load starting must be taken.

If the blower package is operated via a two-speed motor the changeover from high to low speed must be delayed, i.e. the speed must have reduced to the lower speed or the blower must have stopped rotating before the motor is started again at the lower speed.

The motor can be switched directly to the higher speed.

Do not exceed the speed limits when operating the blower package with a frequency converter! At low rotational speeds and high pressure differentials the maximum permissible temperature could be exceeded. (see chapter 1.10).

Attention!

Do not switch the package on and off with the mains isolating switch. Always use the control switch.

8.2 Action to be taken during a Fault



The general safety regulations (see chapter 2) and the corresponding local safety regulations must be observed during fault-finding.

Re-starting after rectification of a fault:

See chapter 7 "Putting into Operation"

Explanation of the symbols used in the following fault diagnosis:

- ⊗1 - Have checked by a specialist.
- ⊗2 - Refer to KAESER customer service.

8.2.1 Abnormal running noises

Possible fault:

Backlash of the gears too large.

Bearing clearance is too large.

Rotors out of time.

Rectification:

Check the backlash. If it is > 0.004" replace the timing gears; ⊗1 or ⊗2.

Measure the clearance. Replace the bearing if necessary; ⊗1 or ⊗2.

Compare the conditions under use concerning pressure difference and speed with the conditions at delivery. Check the rotor chamber for contamination and clean if necessary.

8.2.2 Excessive blower temperature

Possible fault:

Operation with excessive pressure difference.

Contamination of the inlet filter causing degradation of volumetric efficiency.

Rotor clearance too large.

Rectification:

Check the pressure difference and correct if necessary.

Clean inlet filter.

Measure the clearance between the rotors and check with the manufacturer. Rotor replacement could be necessary, ⊗1 or ⊗2.

8.2.3 Oil leaking into the air chamber

Possible fault:

Oil level too high.

Rectification:

Drain the oil until the level is in the middle of the oil level sight glass. Clean out the air chamber with cleanser.

8.2.4 Low inlet volume flow

Possible fault:

Excessive rotor clearance caused by wear, especially by heavily contaminated flow medium.

Inlet flow resistance too high.

Rectification:

Measure the clearance between the rotors and check with the manufacturer. Rotor replacement could be necessary; ⊗1 or ⊗2.

Clean the inlet filter.

9 Maintenance

9.1 Precautions to be Observed during all Maintenance and Servicing



Work on power driven equipment may only be carried out by trained or specialised personnel, see UVV 10.0 (VBG 5).

Before carrying out any maintenance, switch off and lock out the mains isolating switch.

Ensure that no personnel are working on the package before restoring power.



Care must be taken to see that operating materials and used parts are disposed of in a manner conducive to environmental protection.

9.2 Regular Maintenance

Service interval	Work to be done	See chapter
24 hours after first putting into operation	Check drive belts tension and adjust if necessary	9.3
50 hours after first putting into operation	Check all electrical connections for tightness and tighten, if necessary	
500 hours after first putting into operation	Change the lubricating oil	9.6
500 hours or monthly	Check lubricating oil level	9.6
	Check drive belts tension and adjust if necessary	9.3
On series BB: 4000 hours or annually On series DB, EB, FB, HB: 6000 hours or annually	Change the lubricating oil *	9.6
Annually	Check all electrical connections for tightness and tighten if necessary	
	Check pressure relief valve	
	Check condition of drive belts	
10 000 hours or after 4 years.	Grease motor bearings or replace	9.9
12 000 hours or after 2 years	Change drive belts	9.4
See motor nameplate	Grease motor bearings	9.9

* The maintenance period can vary depending on the cut-in frequency and environmental conditions.

We urgently recommend that a record is kept of maintenance work done (see chapter 11.2)

9.3 Checking Drive Belt Tension

☞ Switch off the package (see chapter 8.1)



Switch off and lock out the mains isolating switch to prevent accidental or unauthorised switch-on.

Check the tension of the drive belts after the first 24 hours and then every 500 hours of operation.

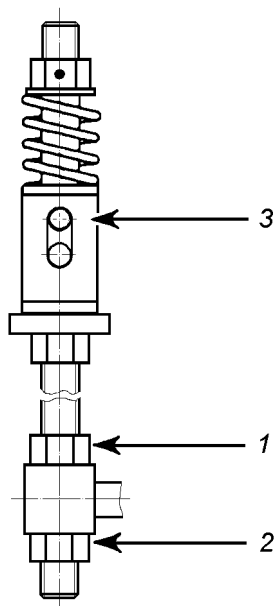

1 & 2 *Adjusting nuts*
3 *Indicator pin*

The tensioning device automatically adjusts the belt tension over a certain range with the aid of a compression spring.

If the drive belts have stretched to the extent that the indicator pin (3) is located at the top end of its slot, the belt tension must be re-adjusted.

Proceed as follows:

- ☞ Loosen nut (1).
- ☞ Tighten the belts with nut (2) until the indicator pin (3) is located at the lower end of the slot.
- ☞ Tighten nut (1) again.

9.4 Changing the Drive Belts

☞ Switch off the package (see chapter 8.1)



Switch off and lock out the mains isolating switch to prevent accidental or unauthorised switch-on.

- ☞ Release nut (2, see chapter 9.3) of the tensioning device.
- ☞ Turn the hexagon nut (1, in section 9.3) so that it moves downwards until belt tension is released.
- ☞ Remove the belts.
- ☞ Lay the new belts over the motor and block pulleys without straining them.
- ☞ Reset the belt tension (see chapter 9.3).
- ☞ Refit the belt guard.
- ☞ Check belt tension after two hours and then again after 24 hours of operation as experience shows that the belts stretch mostly during this period.

Attention! V-belts must be of exactly the same length and so should be changed as a set, not individually. The use of KAESER original parts is highly recommended.

9.5 Lubricating Oil Level Check and Top-Up

Check the lubricating oil level monthly at the gear end and drive end with the package switched off. The oil level should never fall below the middle of the oil level sight glass. The oil level at the sight glass changes during operation because of the rotating parts. For this reason the check the oil level only when the package is stationary.

Attention! If the oil level has fallen to 0.12" below the middle of the oil level sight glass, the blower must be topped up according to the instructions in the oil recommendations.

Never top up above the middle of the oil level sight glass otherwise oil could be forced into the air chamber.

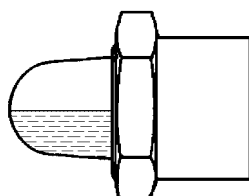

Lubricating oil level at middle of oil level sight glass

- ☞ Top up with lubricating oil via "red" oil filter plugs on the gear and drive ends of the block until the middle of the oil level sight glass is reached (see chapter 1.5).

Attention! The oil chambers of the gear and drive ends are not connected to each other

9.6 Lubricating Oil Change

Attention! Carry out the first lubricating oil change after the first 500 hours of service.

See chapter 9.2. for further lubricating oil change intervals.

- ☞ Drain lubricating oil from the oil drain lines on the gear end drive end.

Attention! Carry out the oil change with the blower block at operational temperature. Open the oil filler plug to ease drainage.



Collect the used oil in a suitable container and dispose of according to environmental regulations!

- ☞ Fill up with new lubricating oil to the middle of the oil level sight glass (see chapter 9.5). Use only the lubricating oil detailed in the oil recommendations (see chapter 1.6).

Attention!

Bleed air from the oil drain lines from the drive end and timing gear end.

9.7 Cleaning the Blower Package

- ☞ Regularly clean the surfaces of the blower and drive motor and keep free of dirt and contamination.

Attention!

Layers of dirt inhibit heat dissipation and damage may occur through overheating.

9.8 Air filter changing

The air filter should be changed every 2500 operating hours or when indicated by the filter monitor.



Switch off and lock out the mains isolating switch to prevent accidental or unauthorised switch-on.

- ☞ Remove the inlet silencer cover
- ☞ Remove the Velcro securing band and take out the old air filter
- ☞ Place the new filter on the perforated inlet port and secure with Velcro band
- ☞ Replace and secure the inlet silencer cover.

9.9 Greasing the Electric Motor

The maximum maintenance-free period of permanently greased motors is at least 10 000 service hours but 4 years maximum.

On motors with a greasing device the amount of grease and the period are shown on name-plate on the motor.

10 Spare Parts and After Sales Service

Nameplate:

		KAESER KOMPRESSOREN GMBH Carl-Kaeser-Str. 26, D-96450 Coburg Germany, Tel.: (0 95 61) 640-0 Fax.: (0 95 61) 640-130	
		Model	Flow capacity m³/min
Serial No.	Inlet pressure kPa (abs.)	Part No.	Outlet pressure kPa (abs.)
Year	Max. pressure diff. kPa	Motor power kW	Blower speed min⁻¹

Important: Enter data from the package nameplate in the diagram above.

Please quote the following information for all queries and orders for spare parts:

1. Rotary blower package, Model:
2. Part No:
3. Serial No:
4. Description of the part:
5. Order number of the part:

Attention! Use only KAESER original spare parts.

11 Appendix

11.1 Instructions on Electrical Connection

(see following page)

Motor Switching Terminal Diagram (constant speed)



Motors for one voltage 575V / 60Hz - Δ – switching

Voltage and switching

Prinziple direct online

External connections

- Voltage: U
- Δ – switching

575V / 60Hz - Δ

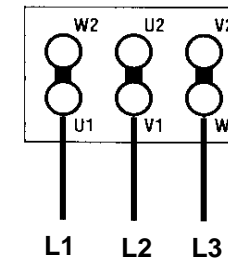
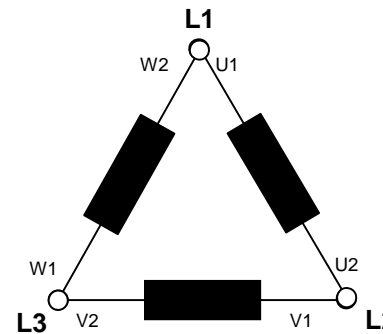

Connection of the integrated PTC thermistors via terminals T1 and T2 in the motor terminal box (Caution: do not connect a voltage higher than 2.5V)

11.3 Safety information concerning contamination of compressors, blowers, vacuum pumps and components

Application and purpose

Every company is responsible for the health and safety of its employees. This extends to personnel who carry out servicing work at the company's premises or at the site of the user.

The attached declaration is intended to inform the service contractor of any possible contamination to be found in compressors, blowers, vacuum pumps or components sent to him for servicing. Based on this information, the service contractor can instigate the necessary protective measures when carrying out the service work.

Preparation for shipment

Before shipping the item(s), the sender should fill out and sign the attached Declaration of Contamination form (one for each item) and attach a copy to the shipping documents and a copy on the outside of the packaging.

Please note the following shipping regulations:

- drain all operating fluids
- remove filter elements
- make all openings airtight
- pack correctly
- ship in suitable container
- fix a copy of the Declaration of Contamination to the **outside** of the packaging

Safety Valve for gauge pressure

Part No.: 891514.00560



Technical Specification

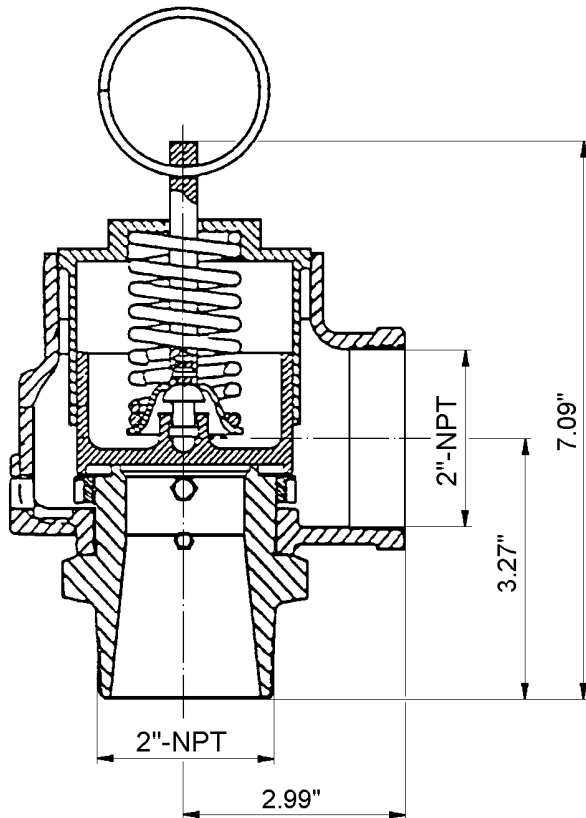

Pressure setting: 8.1 psig

Installation

Installation of the safety valve is only possible in the standing position (see dimensional diagram)

General

The safety valve serves to protect the rotary blower package against excessive pressure. The medium is blown off into the open. The safety valve must be positioned such that no danger can arise. When the blow off valve opens very high noise levels can occur.

Check the safety valve at regular intervals for correct function by opening with the venting lever. The intervals should be set by the user but must be opened at least once annually.

During the blow off check the working pressure should be at least 80% of the pressure setting. Close the blow off valve immediately after the valve blows off.

If contamination causes the safety valve to leak, the valve could be cleaned by blowing off several times.

Attention!

The safety valve is set to the pressure quoted above and sealed. It is not permitted to change the safety valve setting and any such change invalidates all liability whatever.

Check Plate

complete with fixing screws
and gaskets

Part No.: 886943.0

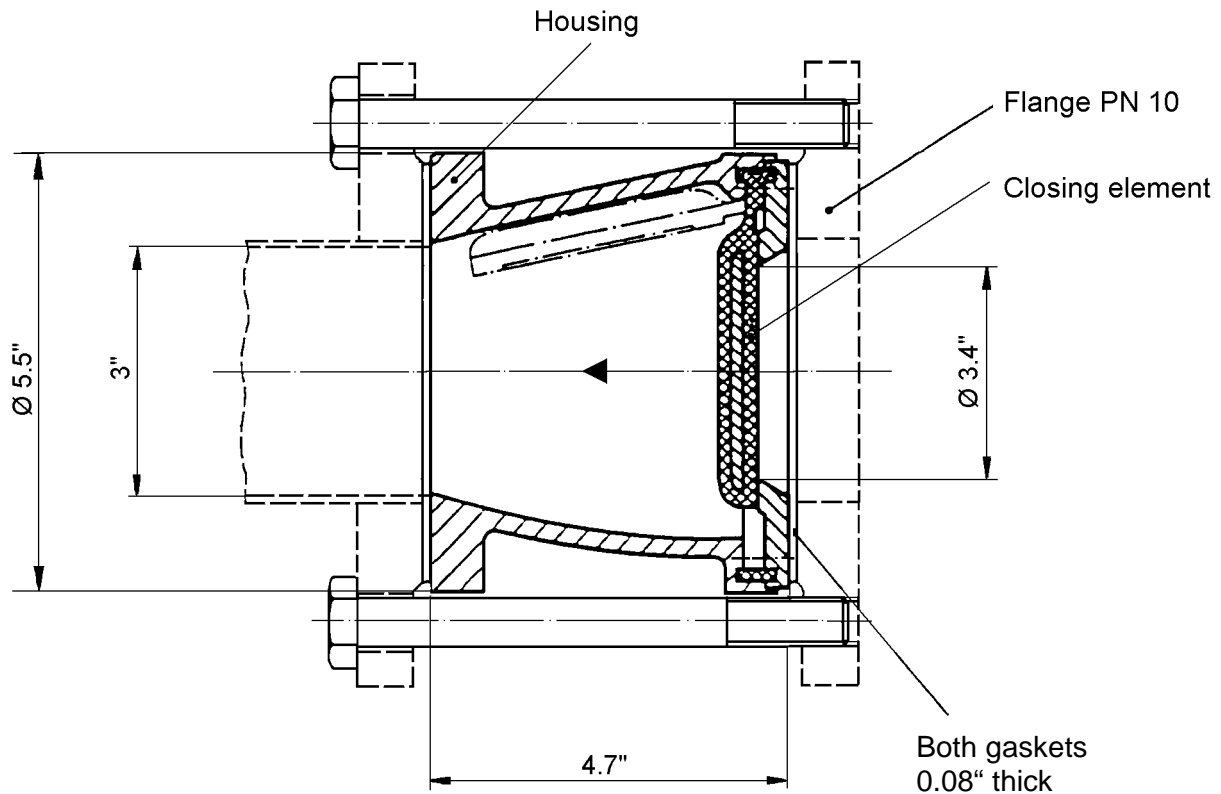

Description

The heart of the check plate is the closing element together with its fixed, vulcanized closing plate.

The check plate allows free through-flow because of the special construction of the housing, the closing element and its fixing. This means in practice that extremely low flow resistance and quiet operation result.

The check plate is secure against blockage, maintenance free and is airtight even with very low back pressures.

Installation

Installation of the check plate is only possible in the horizontal flow direction (in the direction of the arrow). The fixing of the closing element must be at the top. The upper side of the check plate is marked "TOP".

Fitting

Attention! Do not tighten the fixing bolt nuts beyond a torque of 70 Nm.

This is sufficient for a proper seal.

The nuts should be tightened evenly and diagonally opposite.

Attention! Over-tightening can cause damage to the housing.

Maintenance Indicator

For front panel installation



Part No.: 885593.0

Issue: 12/97

- Contents:**
1. Scope of delivery/Spare parts list
 2. Fitting instructions
 3. Diagram of connection to blower package
 4. Function

1. Scope of delivery/Spare parts list

Item No.	No. off	Part No..	Description
1	1	6.0246.0	$\frac{1}{8}$ Male stud fitting tapered
2	2	9.0675.0	Insert for Tecalan pipe
3	1	9.0616.0	Tecalan pipe 7.9"
4	1	885594.0	Fitting for maintenance indicator
5	1	892224.0	Maintenance indicator

2. Fitting instructions

Attention! Carry out this work when the package is shut down only!

- 2.1 Remove the plug at test point "c" on the blower package
- 2.2 Screw in the male stud fitting (item 1) and seal with liquid sealing material
- 2.3 Push the insert (item 2) into one end of the Tecalan pipe (item 3) and fit into the male stud fitting (item 1)
- 2.4 Fit the fitting (item 4) to the maintenance indicator (item 5)
- 2.5 Prepare the connecting point of the maintenance indicator (item 5) to the blower package (if not already done) by removing the cover and any foam behind the cover
- 2.6 Pull off the snap ring from the maintenance indicator (item 5) and insert the ring from the front into the 2.16" diameter hole provided. Push the maintenance indicator into the snap ring from the rear
- 2.7 Push the second insert (item 2) into the free end of the Tecalan pipe (item 3) and connect the pipe to the fitting (item 4)

3. Diagram of connection to blower package

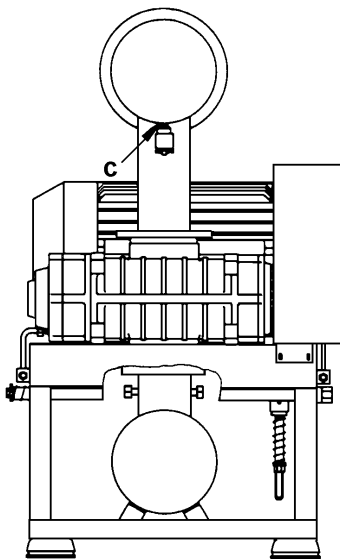

4. Function

If the maintenance indicator moves into the red area the air filter is clogged up and must be serviced. After servicing reset the indicator by pressing the knob.

Pressure Gauge

Part No.: 884225.0

Issue: 1/96

- Contents:**
1. Scope of Delivery/Spare Parts List
 2. Installation Instructions
 3. Diagram showing connection of Measuring Points on the Blower Package

1. Scope of Delivery/Spare Parts List

Item No.	No. off	Order No.	Description
1	1	890458.0	Male stud fitting ¼ taper
2	2	9.0675.0	Insert for Tecalan pipe
3	1	9.0616.0	Tecalan pipe, 2 m long
4	1	6.1704.0	Pressure gauge fitting
5	1	891485.1	Pressure gauge, 23.2 psi

2. Installation Instructions

Remove all power from the package before commencing work !

- 2.1 Remove the screw plug at measuring point "a" on the blower package.
- 2.2 Screw in the male stud fitting (item 1) and seal with liquid sealing material.
- 2.3 Push the Tecalan pipe insert (item 2) into one end of the Tecalan pipe (item 3) and fit into the fitting (item 1).
- 2.4 Fit the pressure gauge fitting (item 4) to the gauge (item 5).
Caution! lay in the sealing ring first.
- 2.5 If not already done, prepare the fitting point for the pressure gauge (item 5) by removing the cover and any foam that may be present.
- 2.6 After removing the clamp, push the pressure gauge (item 5) into the 2.52" hole provided and affix with the clamp.
- 2.7 Push the insert (item 2) into the free end of the Tecalan pipe (item 3) and connect the pipe to the vacuum gauge fitting (item 4).

3. Diagram showing connection of Measuring Points on the Blower Package

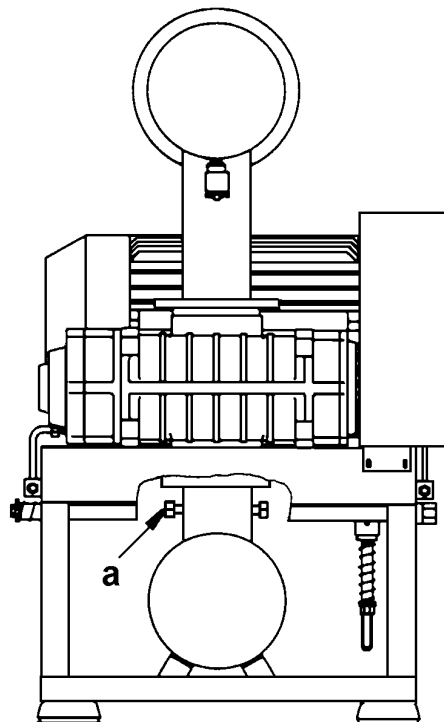

Temperature Gauge Switch



Part No.: 884625.0

Issue: 1/96

Contents:

1. Scope of Delivery/Spare Parts List
2. Installation Instructions
3. Diagram showing connection of Measuring Points on the Blower Package

1. Scope of Delivery/Spare Parts List

Item No.	No. off	Order No.	Description
1	1	883838.0	Protective sleeve
2	1	6.1533.0	Sealing ring
3	1	891636.0	Temperature gauge switch

2. Installation Instructions

Attention!

Switch off and lock out all power supplies before commencing work.

- 2.1 Remove the screw plug at measuring point "b" on the blower package.
- 2.2 Screw in the protective sleeve (item 1) with the sealing ring (item 2), into the measuring point.
- 2.3 Remove the clamp and protective cap over the terminals. Connect the terminals (5A/220V 50/60 Hz non-inductive; on/off gauge switch without return). Replace the protective cap.
- 2.4 Push the temperature gauge switch (item 3) into the 2.38 " hole provided and affix with the clamp.
- 2.5 Lay the remote line to the protective sleeve and screw the heat sensor into the protective sleeve. Feed the supply cable through the cable grommet in the sound enclosure to the outside.
- 2.6 Set the required switching point with the rotary knob on the front.
Max. switching point: 240 °F inlet temperature

3. Diagram showing connection of Measuring Points on the Blower Package

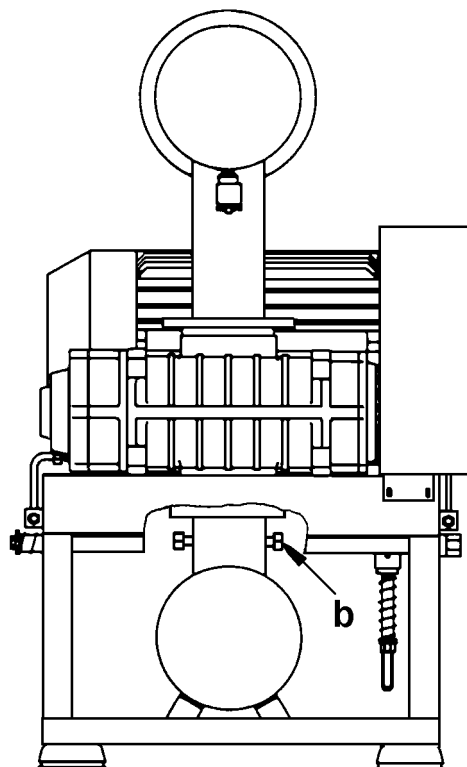



Installation instructions

**Transportable
sound enclosure
for rotary blower packages**

DB 130 C pr

Part no.: 882246.10510

Contents

- 1 Scope of Delivery
- 2 Technical Specification
- 3 Intended use
- 4 Construction
- 5 Rotary Blower Package Maintenance
- 6 Assembly
- 7 Electrical Diagrams

1 Scope of Delivery

The sound enclosure is supplied already fitted to the blower.

2 Technische Daten

Dimensions: L x W x H 52.2" x 44.5" x 57.1"

Weight: ~ 441 lbs

Sound reduction: ~ 18 - 20 dB

Fan power supply: see 7

2.1 Dimensional drawing

(see following page)

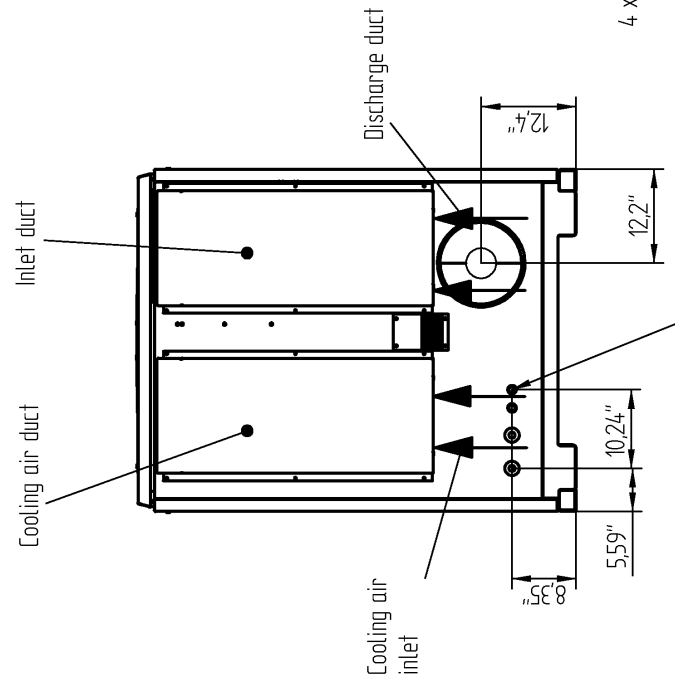
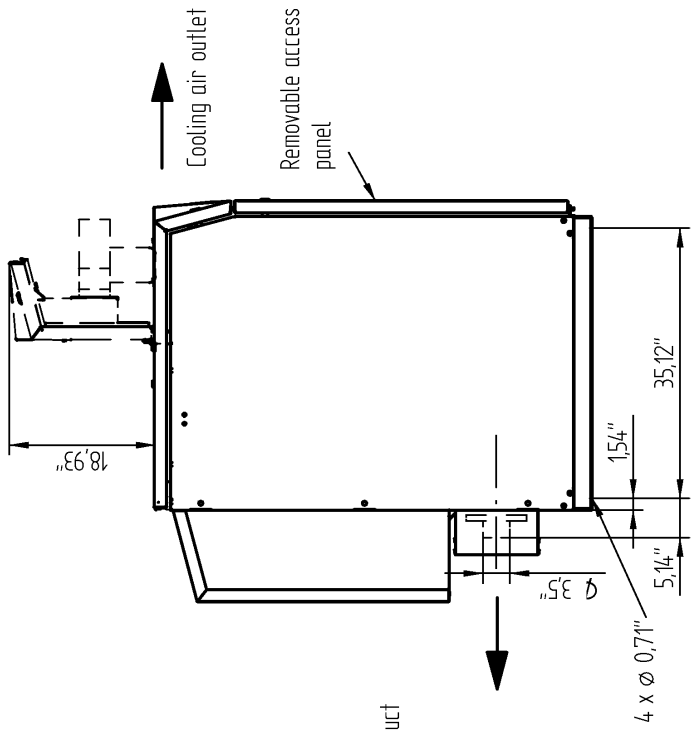
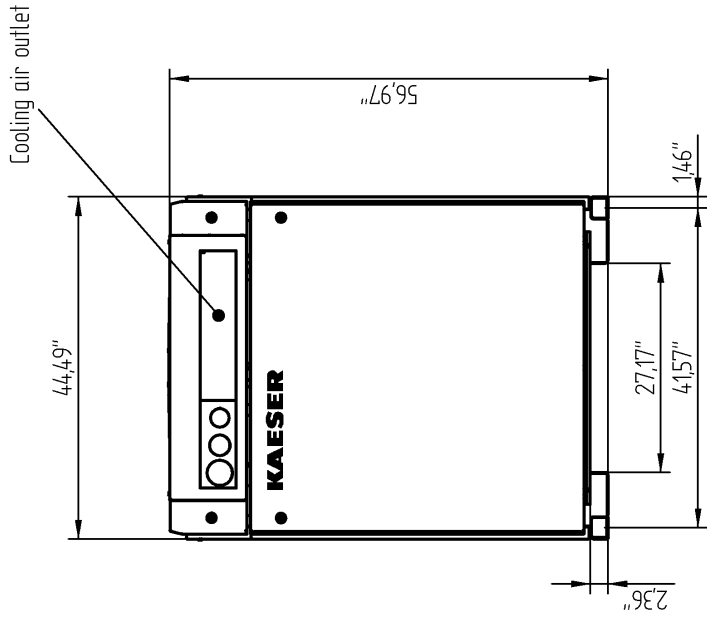
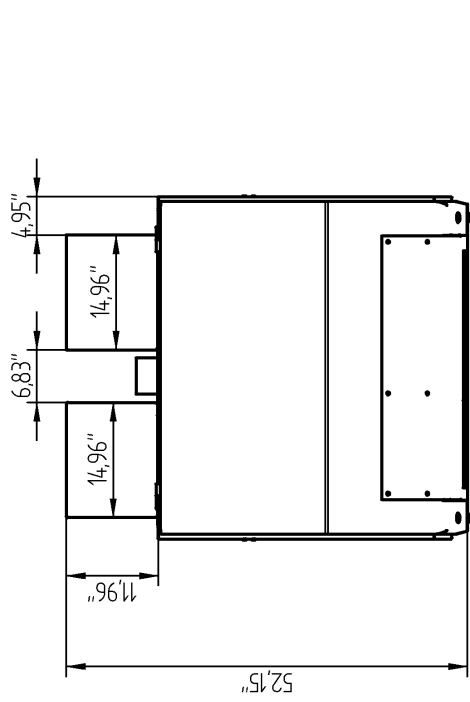

Cable leadthrough
2x grommets Ø 1,49"
2x grommets Ø 0,83"

DB 130 C pr

Stand:	Datum:	Name:	CAD-Datei:
28.06.02	28.06.02	Lummer	MB001615.dft



3 Intended use

The sound enclosure is intended to reduce the sound emission from a rotary blower.

When installed in rotary blower package a compact unit is formed that can be transported by fork truck.

4 Construction

The transportable base frame supports the soundproof enclosure which consists of three side panels, a removable panel and a lift up cover.

The powder-coated steel panels are lined with 1.57" thick sound absorbing material.

4.1 Airflow

A fan on the motor draws air into the enclosure through the air inlet opening to provide cooling for the motor and as inlet air for the blower.

A fan mounted in the discharge air deflector strengthens the airflow to improve cooling in the enclosure.

Never block the apertures through improper installation or by objects.

Process air is drawn in through a separate opening or duct. In this case, it must be ensured that the air to be compressed is at ambient temperature.

Reducing the size of the cooling air inlet and exhaust openings will lead to malfunctioning of the blower package and the sound enclosure.

5 Rotary Blower Package Maintenance

Access to the inlet silencer for maintenance is by means of the lift-up cover and the removable panel.

Access can also be obtained from here to the terminal box and motor bearing greasing point. The belt tension can be seen and adjusted if necessary.

The air filter service warning indicator can be seen as well as the oil level in the block. The oil can be changed from this position when necessary.

The ventilator fan and terminal box can be accessed.

The function of blow-off and inlet valves can be checked.

The unloaded start valve can be adjusted.

6 Assembly

The sound enclosure is supplied already fitted to the blower.

When placed in position, the following must be carried out:

- Electrical connection to the fan motor in accordance with local regulations and with reference to the electrical diagram.
Ensure that there is no tension on the connecting cable, that it is of sufficient length and that fuses are connected.
- Attach the collar halves to the compensator hose at the end of the port and fix with counter-sunk screws.

7 Electrical Diagrams

Fan CMP 514 2M (Part No. 893817.0)

1-phase fan motor

Voltage/frequency:	115 V / 60 Hz
Power:	0.27 h.p. (60 Hz)
Current:	3.8 A (60 Hz)
Rated speed:	3400 rpm (60 Hz)
Enclosure protection:	IP55
Connection:	direct to the motor terminal box

Connection fan motor

Look inside cover terminal box.

Max. delivery of fan: 588.6 CFM (60 Hz)

Connecting Instructions

- The fan motor should be so connected that it runs concurrent with the blower motor.
- Direction of airflow is out of the sound enclosure.
- Make sure that earth is connected. Make sure that cables connected in the terminal box are not under mechanical tension.
- If the fan stops while the rotary blower is in operation the temperature inside the enclosure can rise to an unacceptable level.
- In such a case, a supply of cooling air must be provided or the blower motor stopped to avoid damage.
- If the fan is arranged to continue running for about 15 minutes after the blower motor has stopped, this improves the thermal conditions in the sound enclosure.

Attention!

The connection to the power supply and protective measures taken must be carried out to the provisions of the local electricity supply authority by a qualified electrician.



FOREWORD

The electric motor is an equipment widely used by man in the industrial development as most of the machines he has been inventing depend on it.

Taking into consideration the prominent role the electric motor plays on people's life, it must be regarded as a prime power unit embodying features that require special care including its installation and maintenance in order to ensure perfect operation and longer life to the unit. This means that the electric motor should receive particular attention.

The **INSTALLATION AND MAINTENANCE MANUAL FOR LOW VOLTAGE THREE-PHASE INDUCTION MOTORS** intends to assist those who deal with electric machines facilitating their task to preserve the most important item of the unit:

THE ELECTRIC MOTOR.

WEG





TABLE OF CONTENTS

1 - INTRODUCTION	1-03
2 - BASIC INSTRUCTIONS	1-03
2.1 - General Instructions	1-03
2.2 - Delivery	1-03
2.3 - Storage	1-03
3 - INSTALLATION	1-04
3.1 - Mechanical Aspects	1-04
3.1.1 - Foundation.....	1-04
3.1.2 - Types of bases	1-04
3.1.3 - Alignment	1-04
3.1.4 - Coupling	1-05
3.2 - Electrical Aspects	1-09
3.2.1 - Power Supply System.....	1-09
3.2.2 - Starting of Electric Motors	1-09
3.2.3 - Motor Protection	1-10
3.3 - Start-up	1-11
3.3.1 - Preliminary Inspection	1-11
3.3.2 - The First Start-up	1-11
3.3.3 - Operation	1-12
3.3.4 - Stopping	1-12
4 - MAINTENANCE	1-15
4.1 - Cleanliness	1-15
4.2 - Lubrication	1-15
4.2.1 - Lubrication Intervals	1-15
4.2.2 - Quality and Quantity of Grease	1-15
4.2.3 - Lubrication Instructions	1-15
4.2.4 - Replacement of Bearings	1-15
4.3 - Miscellaneous Recommendations	1-16
5 - ABNORMAL SITUATIONS DURING OPERATION.....	1-20
5.1 - Analysis of some abnormal situations and possible causes on electric motors.....	1-20





1 - INTRODUCTION

This manual covers all WEG asynchronous induction squirrel cage motors, that is, three phase motors in frames 63 to 355, and single-phase motors.

The motors mentioned in this manual are subject to continuous improvement. Therefore, any information is subject to change without prior notice.

For further details, please contact WEG.

2 - BASIC INSTRUCTIONS

2.1 - GENERAL INSTRUCTIONS

All personnel involved with electrical equipment, either installation, operation or maintenance should be well-informed and updated concerning the safety norms and principles that govern the work and, furthermore, they are advised to heed them. Before work commences, it is the responsibility of the person in charge to ascertain that these have been duly complied with and to alert his personnel of the inherent hazards of the job in hand.

It is recommended that these tasks be undertaken by qualified personnel.

Fire fighting equipment, and notices concerning first aid should not be lacking at the work site; these should be visible and accessible at all times.

2.2 - DELIVERY

Prior to shipment, motors are factory-tested and dynamically balanced. With half key to ensure perfect operation.

Upon receipt, we recommend careful handling and a physical checking for any damage which may have occurred during transportation.

In the event of any damage, both the nearest WEG sales office and the carrier should be informed immediately.

2.3 - STORAGE

Motors should be lifted by their eyebolts and never by the shaft. Raising and lowering must be steady and joltless, otherwise bearings may be damaged.

When motors are not immediately installed, they should be stored in their normal upright position in a dry even temperature place, free of dust, gases and corrosive smoke. Other objects should not be placed on or against them.

Motors stored over long periods are subject to loss of insulation resistance and oxidation of bearings.

Bearings and the lubricant deserve special attention during long periods of storage. Depending on the length and conditions of storage it may be necessary to regrease or change rusted bearings. The weight of the rotor in an inactive motor tends to expel grease from the bearing surfaces thereby removing the protective film that impedes metal-to-metal contact. As a preventive measure against the formation of corrosion by contact, motors should not be stored near machines which cause vibrations, and their shaft should be rotated manually at least once a month.

Recommendations for Storage of Bearings:

- Ambient must be dry with relative humidity not exceeding 60%.
- Clean room with temperature ranging from 10°C to 30°C.
- Maximum stacking of 5 boxes.
- Far from chemical products and tubes conducting steams, water and compressed air.
- They should not be stacked over stone floors or against walls.
- Stock should follow the first-in-first-out principle.
- Double shielded bearings should not remain in stock for more than 2 years.

Storage of motors:

- Mounted motors which are kept in stock must have their shaft turned periodically, at least once a month, in order to renew the grease on the bearing races.

It is difficult to prescribe rules for the actual insulation resistance value of a machine as the resistance varies according to the type, size and rated voltage and the state of the insulation material used, method of construction and the machine's insulation antecedents. A lot of experience is necessary to decide when a machine is ready or not to be put into service. Periodical records are useful to take such decision.

The following guidelines show the approximate values that can be expected of a clean and dry machine when, at 40°C, test voltage is applied over a period of one minute.

Insulation resistance R_m is obtained by the formula:

$$R_m = U_n + 1$$

where:

- R_m - minimum recommended insulation resistance in $M\Omega$ with winding at 40°C.
- U_n - machine rated voltage in kV.

In case that the test is carried out at a temperature other than 40°C, the reading must be corrected to 40°C using a curve of insulation resistance vs. temperature for the particular machine. If such curve is not available, an approximation is possible with the aid of Figure 2.1; it is possible to verify that resistance practically doubles every 10°C that insulating temperature is lowered.

On new machines, lower values are often attained due to solvents present in the insulating varnishes that later evaporate during normal operation. This does not necessarily mean that the machine is not operational, since insulating resistance will increase after a period of service.

On motors which have been in service for a period of time, much larger values are often attained. A comparison of the values recorded in previous tests on the same machine, under similar load, temperature and humidity conditions, serves as a better indication of insulation condition than that of the value coming from a single test. Any substantial or sudden reduction is suspect.

Insulation resistance is usually measured with a MEGGER. In the event that insulation resistance be inferior to the values coming from the above formula, motors should be submitted to a drying process.

This drying process should be carried out in a stove, where the rate of temperature rise should not exceed 5°C per hour and the temperature should not exceed 110°C.

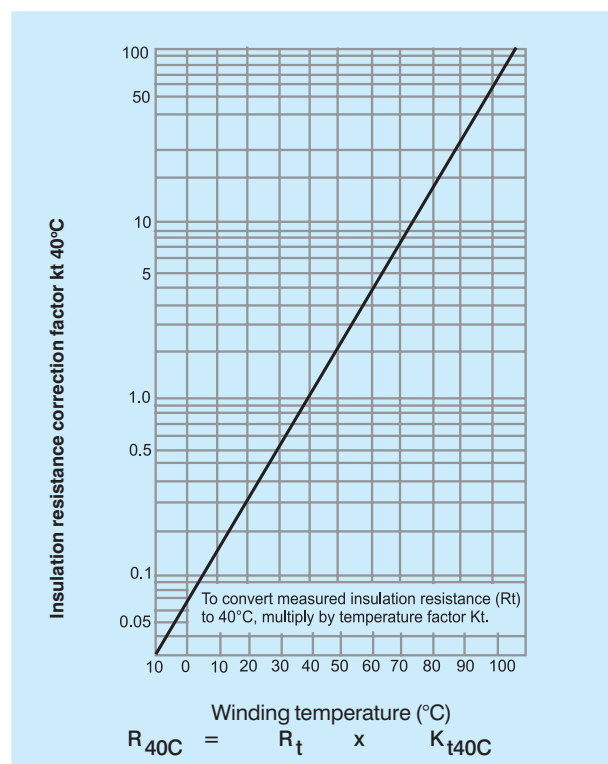

Fig. 2.1 Approximate calculation curve of the insulation resistance.





3 - INSTALLATION

Electric machines should be installed in such a way to allow easy access for inspection and maintenance. Should the surrounding atmosphere be humid, corrosive or containing flammable substance or particles, it is essential to ensure an adequate degree of protection. The installation of motors on ambients where there are steams, gases or dusts, flammable or combustible materials, subject to fire or explosion, should be undertaken according to appropriate and governing codes, such as ABNT/IEC 7914, NBR 5418, VDE 0165, NEC-ART. 500, UL-674.

Under no circumstances motors can be enclosed in boxes or covered with materials which may impede or reduce the free circulation of cooling air.

Machines fitted with external ventilation should be at least 50cm far from the wall to permit air movement.

The place of installation should allow for air renewal at a rate of 20 cubic meter per minute for each 100kW of motor output considering ambient temperature of 40°C and altitude of 1000 m.a.s.l.

3.1 - MECHANICAL ASPECTS

3.1.1 - FOUNDATION

The motor base must be level and as far as possible free of vibrations. A concrete foundation is recommended for motors over 100 HP (75kW).

The choice of base will depend upon the nature of the soil at the place of installation or of the floor capacity in the case of buildings. When designing the motor base, keep in mind that the motor may occasionally be run at a torque above that of the rated full load torque.

Based upon Figure 3.1, foundation stresses can be calculated by using the following formula:

$$F1 = 0.5.g.G - \frac{4 T_{max}}{A} \quad F2 = 0.5.g.G + \frac{4 T_{max}}{A}$$

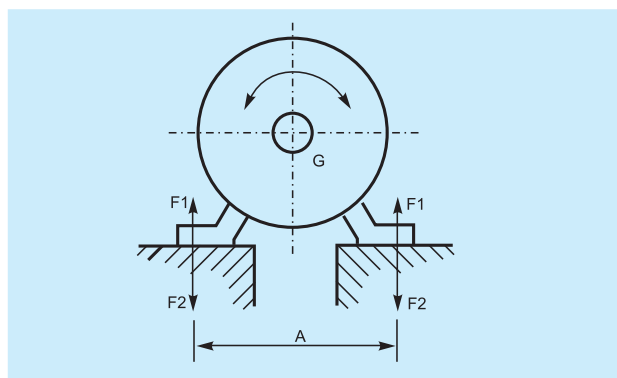

Fig. 3.1 - Base Stresses

Where:

- F1 and F2 - Lateral Stress (N)
- g - Gravity Force (9.8m/s²)
- G - Motor Weight (kg)
- Tmax - Breakdown torque (Nm)
- A - Obtained from the dimensional drawing of the motor(m)

Sunken bolts or metallic base plates should be used to secure the motor to the base.

3.1.2 - TYPES OF BASES

a) Slide Rails

When motor drive is by pulleys the motor should be mounted on slide rails and the lower part of the belt should be pulling to avoid belt slippage during operation and also to avoid the belts to operate sideways causing damage to bearing shoulders.

The rail nearest the drive pulley is positioned in such a way that the adjusting bolt be between the motor and the driven machine. The other rail should be placed with the bolt in the opposite position, as shown in Fig. 3.2.

The motor is bolted to the rails and set on the base. Drive and driven pulley centers must be correctly aligned on the same way, motor and driven machine shafts must be parallel.

The belt should not be overly stretched, see Fig. 3.10. After the alignment, the rails are fixed, as shown below:

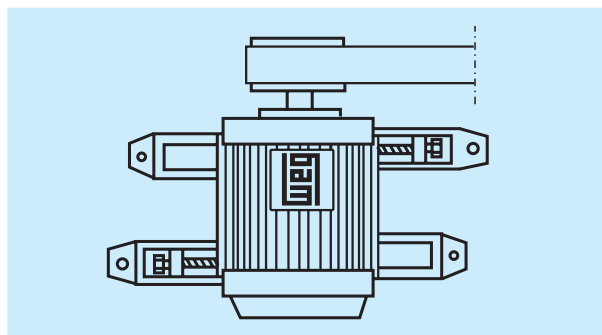

Fig. 3.2 - Positioning of slide rails for motor alignment.

b) Foundation Studs

Very often, particularly when drive is by flexible coupling, motor is anchored directly to the base with foundation studs.

This type of coupling does not allow any thrust over the bearings and it is of low cost.

Foundation studs should neither be painted nor rusted as both interfere with the adherence of the concrete, and bring about loosening.

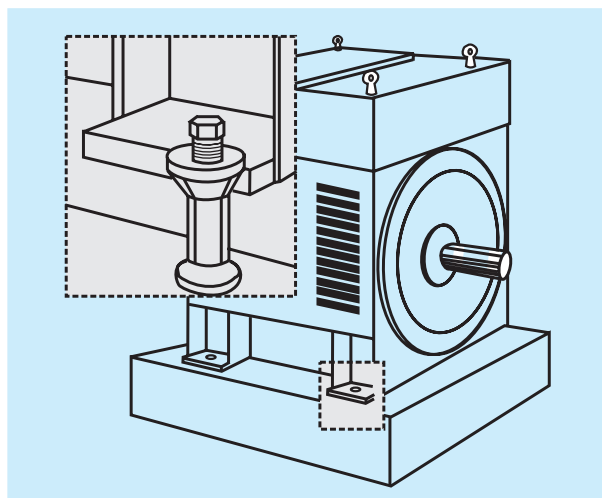

Fig. 3.3 - Motor mounted on a concrete base with foundation studs.

c) Metallic Base

Motor-generator sets are assembled and tested at the factory prior to delivery. However, before putting into service at site, coupling alignment should be carefully checked as the metallic base could have suffered displacement during transit due to internal stresses of the material.

The metallic base is susceptible to distortion if secured to a foundation that is not completely flat.

Machines should not be removed from their common metallic base for alignment; the metallic base should be level on the actual foundation with the aid of a spirit level (or similar instrument).

When a metallic base is used to adjust the height of the motor shaft end with the machine shaft end, the latter should be level on the concrete base.

After the base has been levelled, foundation, studs tightened, and the coupling checked, the metal base and the studs are cemented.

3.1.3- ALIGNMENT

The electric motor should be accurately aligned with the driven machine, particularly in cases of direct coupling. An incorrect alignment can cause bearing failure, vibrations and even shaft rupture.

The best way to ensure correct alignment is to use dial gauges





placed on each coupling half, one reading radially and the other axially. Thus, simultaneous readings are possible and allow checking for any parallel (Fig. 3.4) and concentricity deviations (Fig. 3.5) by rotating the shafts one turn. Gauge readings should not exceed 0.05 mm.

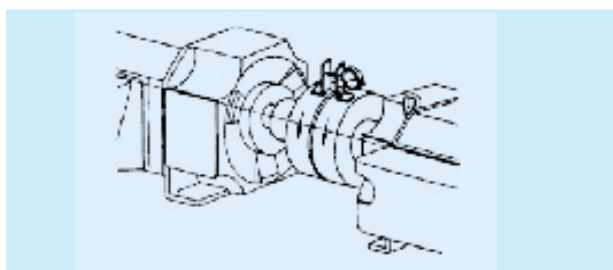

Fig. 3.4 - Deviation from parallelism

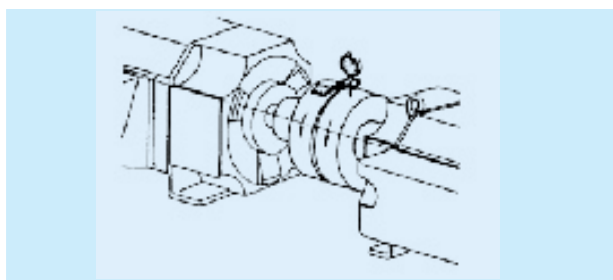

Fig. 3.5 - Deviation from concentricity

3.1.4- COUPLING

a) Direct Coupling

Direct coupling is always preferable due to low cost, space economy, no belt slippage and lower accident risk. In cases of speed ratio drives, it is also common to use a direct coupling with a reducer (gear box).

CAUTION: Carefully align the shaft ends using, whenever feasible, a flexible coupling, leaving a minimum tolerance of 3 mm between the couplings (GAP).

b) Gear Coupling

Poorly aligned gear couplings are the cause of jerking motions which cause vibrations on the actual drive and on the motor. Therefore, due care must be taken for perfect shaft alignment: exactly parallel in the case of straight gears and at the correct angle for bevel or helical gears.

Perfect gear engagement can be checked by the insertion of a strip of paper on which the teeth marks will be traced after a single rotation.

c) Belt and Pulley Coupling

Belt coupling is most commonly used when a speed ratio is required.

Assembly of Pulleys: To assemble pulleys on shaft ends with a keyway and threaded end holes the pulley should be inserted halfway up the keyway merely by manual pressure.

On shafts without threaded end holes, the heating of the pulley to about 80°C is recommended, or alternatively, the devices illustrated in Figure 3.6 may be employed.

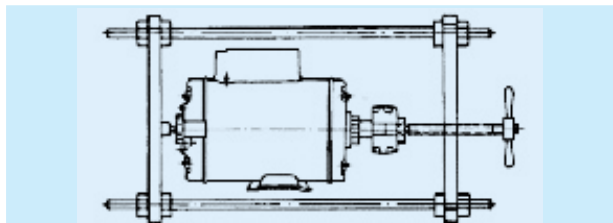

Fig. 3.6 - Pulley mounting device

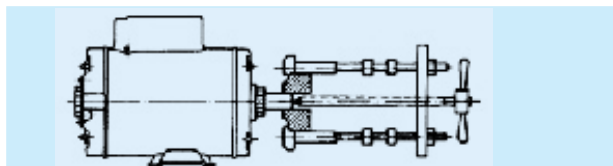

Fig. 3.7 - Pulley extractor

Hammers should be avoided during the fitting of pulleys and bearings. The fitting of bearings with the aid of hammers leaves blemishes on the bearing races. These initially small flaws increase with usage and can develop to a stage that completely impairs the bearing. The correct positioning of a pulley is shown in Figure 3.8.

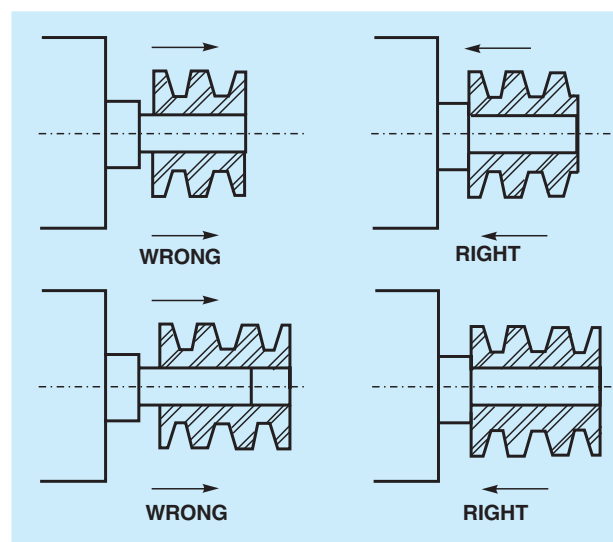

Fig. 3.8 - Correct positioning of pulley on the shaft.

RUNNING: To avoid needless radial stresses on the bearings it is imperative that shafts are parallel and the pulleys perfectly aligned. (Figure 3.9).

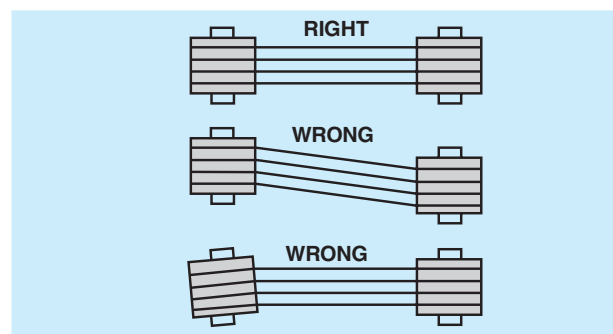

Fig. 3.9 - Correct pulley alignment

Pulleys that are too small should be avoided; these cause shaft flexion because belt traction increases in proportion to a decrease in the pulley size. Table 1 determines minimum pulley diameters, and Table 2 and 3 refer to the maximum stresses acceptable on motor bearings up to frame 355.

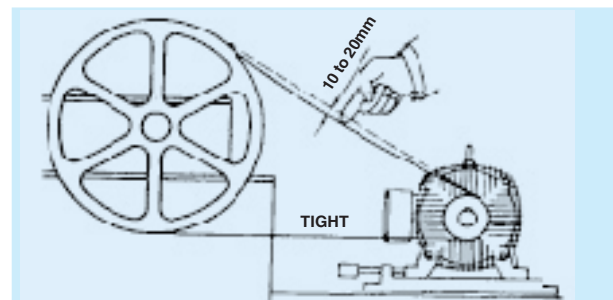

Fig. 3.10 - Belt tensions

Laterally misaligned pulleys, when running, transmit alternating knocks to the rotor and can damage the bearing housing. Belt slippage can be avoided by applying a resin (rosin for example). Belt tension should be sufficient to avoid slippage during operation.



TABLE - 1

MINIMUM PITCH DIAMETER OF PULLEYS							
Frame	BALL BEARINGS						
	Bearing	Size X (mm)					
		20	40	60	80	100	120
63	6201-ZZ	40	---	---	---	---	---
71	6203-ZZ	40	40	---	---	---	---
80	6204-ZZ	40	40	---	---	---	---
90	6205-ZZ	63	71	80	---	---	---
100	6206-ZZ	71	80	90	---	---	---
112	6307-ZZ	71	80	90	---	---	---
132	6308-ZZ	---	100	112	125	---	---
160	6309-Z-C3	---	140	160	180	200	---
180	6311-Z-C3	---	---	160	180	200	224
200	6312-Z-C3	---	---	200	224	250	280

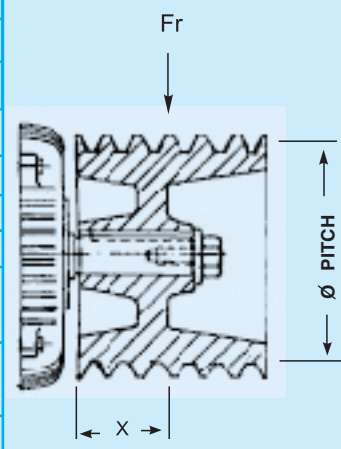

Table 1.1

Frame	Poles	BALL BEARINGS				
		Bearing	Size X (mm)			
			50	80	110	140
225	IV-VI-VIII	6314	250	265	280	300
250	IV-VI-VIII	6314	375	400	425	450
280	IV-VI-VIII	6316	500	530	560	600
315	IV-VI-VIII	6319	-----	-----	-----	-----
355	IV-VI-VIII	6322	-----	-----	-----	-----

For II pole motors, contact Weg.

TABLE 1.2

Frame	Poles	Roller Bearings						
		Bearing	Size x (mm)					
			50	80	100	140	170	210
225	IV-VI-VIII	NU 314	77	80	110	136	-----	-----
250	IV-VI-VIII	NU 314	105	115	145	175	-----	-----
280	IV-VI-VIII	NU 316	135	140	170	210	-----	-----
315	IV-VI-VIII	NU 319	-----	170	185	225	285	-----
355	IV-VI-VIII	NU 322	-----	-----	345	410	455	565



TABLE 2

MAXIMUM ACCEPTABLE RADIAL LOAD (N) - IP55 MOTORS - 60HZ				
FRAME	POLES			
	II	IV	VI	VIII
63	245	294	-----	-----
71	294	392	-----	-----
80	343	491	-----	-----
90	392	540	589	687
100	589	785	883	981
112	1040	1275	1472	1668
132	1275	1570	1864	1962
160	1570	1962	2256	2551
180	2060	2649	3041	3434
200	2354	3139	3630	4120
225	3041	4120	4415	5003
250	2845	3728	4316	4807
280	3532	4513	5101	5690
315	3335	4905	5690	6475
355	----	15402	15402	15402

MAXIMUM ACCEPTABLE RADIAL LOAD (N) - IP55 MOTORS - 50HZ				
FRAME	POLES			
	II	IV	VI	VIII
63	245	294	-----	-----
71	294	392	-----	-----
80	343	491	-----	-----
90	392	589	638	687
100	589	834	932	1079
112	1079	1373	1570	1766
132	1373	1668	1962	2060
160	1668	2060	2403	2698
180	2158	2796	3237	3630
200	2502	3335	3826	4365
225	3237	4365	4709	5297
250	3041	3924	4611	5101
280	3728	4807	5396	5984
315	3532	5199	5984	6867
355	----	16285	16285	16285

TABLE 2.1

MAXIMUM ACCEPTABLE RADIAL LOAD (Kgf) - 60HZ AND 50HZ				
NEMA 56 MOTORS (SINGLE-PHASE)				
FRAME	RADIAL FORCE (N)			
	POLES			
	II	IV	VI	VIII
56 A	245	343	-----	-----
56 B	294	343	-----	-----
56 D	343	441	-----	-----
SAW ARBOR MOTORS (THREE-PHASE)				
80 S - MS	981	-----	-----	-----
80 H - MS	981	-----	-----	-----
80 L - MS	981	-----	-----	-----
90 L - MS	1275	1570	-----	-----





Concerning ODP NEMA 48 & 56 fractional motors, these have the following features:

- Rotor: Squirrel cage
- Protection: Open drip proof
- Insulation: Class "B" (130°C) - IEC 34
- Cooling system: internal

- Bearings: Ball
- Standards: NEMA MG-1
- Voltage: Single phase: 110/220V
Three phase: 220/380V
- Frequency: 60Hz and 50Hz

For more information referring to motor features, please contact WEG.

TABLE 3

MAXIMUM ACCEPTABLE AXIAL LOAD (N) - f = 60 Hz																
TOTALLY ENCLOSED FAN COOLED MOTORS - IP55																
F R A M E	POSITION / MOUNTING CONFIGURATION															
	II	IV	VI	VIII	II	IV	VI	VIII	II	IV	VI	VIII	II	IV	VI	VIII
63	275	363	422	-	275	363	422	-	265	343	412	-	265	343	412	-
71	294	402	471	530	363	491	579	647	284	383	451	520	353	481	559	638
80	353	481	559	638	471	647	755	844	334	451	530	608	461	618	726	824
90	451	618	746	834	491	667	824	922	422	569	706	785	461	628	775	873
100	481	657	795	903	687	932	1128	1275	432	589	726	834	638	873	1069	1207
112	677	912	1109	1275	1197	1628	1972	2227	608	824	1020	1187	1138	1540	1874	2139
132	834	1158	1383	1570	1422	1982	2364	2659	706	1010	1207	1364	1305	1825	2178	2453
160	1197	1648	1884	2168	2040	2747	3178	3620	952	1383	1560	1884	1795	2482	2855	3335
180	-	2178	2492	2815	-	3718	4307	4846	-	1825	1991	2315	-	3375	3806	4365
200	1668	2207	2659	3041	3129	4130	4895	5552	1197	1579	2040	2472	2659	3483	4277	4983
225	3983	5278	6200	6985	3983	5278	6200	6985	3335	4454	5297	6082	3335	4454	5297	6082
250	3895	5180	6053	6828	3895	5180	6053	6828	3129	4169	4876	5651	3129	4169	4876	5651
280	3747	5964	7073	7985	3747	5964	7073	7985	2541	4424	5307	6239	2541	4424	5307	6239
315	3424	5562	6622	7514	3424	5562	6622	7514	1579	3208	3924	4836	1579	3208	3924	4836
355	3120	6259	7338	8299	3120	6259	7338	8299	451	2109	2443	2659	451	2109	2443	2659

MAXIMUM ACCEPTABLE AXIAL LOAD (N) - f = 50 Hz																
TOTALLY ENCLOSED FAN COOLED MOTORS - IP55																
F R A M E	POSITION / MOUNTING CONFIGURATION															
	II	IV	VI	VIII	II	IV	VI	VIII	II	IV	VI	VIII	II	IV	VI	VIII
63	294	392	441	-	294	392	441	-	284	363	441	-	294	392	441	-
71	314	432	491	559	392	520	618	687	304	402	481	549	373	510	589	677
80	373	510	589	677	491	687	785	893	353	481	559	647	491	657	765	873
90	481	657	785	883	520	706	873	981	441	618	746	834	491	667	824	922
100	510	697	844	961	726	981	1197	1354	461	628	765	883	677	922	1128	1275
112	716	961	1177	1354	1275	1727	2090	2354	647	873	1079	1256	1207	1628	1982	2266
132	883	1226	1472	1668	1511	2080	2502	2815	765	1069	1275	1442	1383	1933	2305	2600
160	1275	1746	1991	2296	2158	2914	3375	3836	1010	1472	1658	1991	1903	2629	3021	3532
180	-	2305	2649	2982	-	3944	4562	5131	-	1933	2109	2453	-	3581	4032	4630
200	1766	2335	2815	3227	3316	4375	5189	5886	1275	1668	2158	2619	2815	3689	4532	5278
225	4218	5592	6573	7407	4218	5592	6573	7407	3532	4719	5611	6445	3532	4719	5611	6445
250	4120	5494	6416	7230	4120	5494	6416	7230	3316	4415	5160	5984	3316	4415	5160	5984
280	3973	6318	7505	8466	3973	6318	7505	8466	2688	4689	5621	6612	2688	4689	5621	6612
315	3630	5886	7014	7966	3630	5886	7014	7966	1668	3404	4159	5121	1668	3404	4159	5121
355	3306	6632	7779	8790	3306	6632	7779	8790	481	2237	2590	2815	481	2237	2590	2815





TABLE3.1

MAXIMUM ACCEPTABLE AXIAL LOAD (N) - f = 60 Hz and 50Hz								
F R A M E	POSITION / MOUNTING CONFIGURATION FRAME							
	II	IV	II	IV	II	IV	II	IV
56 A	294	392	363	491	275	373	343	471
56 B	294	392	353	481	275	363	343	461
56 D	275	383	461	638	255	353	441	608

3.2 - ELECTRICAL ASPECTS

3.2.1- POWER SUPPLY SYSTEM

Proper electric power supply is very important. The choice of motor feed conductors, whether branch or distribution circuits, should be based on the rated current of the motors as per IEC 34 Standard.

NOTE: In the case of variable speed motors, the highest value among the rated currents should be considered. When motor operation is intermittent the conductors should have a current carrying capacity equal or greater, to the product of the motor rated current times the running cycle factor shown in Table 4.

IMPORTANT: For a correct choice of motor feed conductors, we recommend to check the standards requirements for industrial installations.

TABLE 4

Service Duty Factor				
Motor Rated Service Time	5 min.	15 min.	30 to 60 min.	Continuous
Classification				
Short (valve operation, contact operation, etc.)	1.10	1.20	1.50	-
Intermittent (load or building elevators, tools, pumps, rolling bridges, etc.)	0.85	0.85	0.90	1.40
Periodical (Rolling mill, mining machines, etc.)	0.85	0.90	0.95	1.40
Variable	1.10	1.20	1.50	2.00

3.2.2 - STARTING OF ELECTRIC MOTORS

Induction motors can be started by the following methods:

DIRECT STARTING

Whenever possible a three phase motor with a squirrel cage should be started directly at full voltage supply by means of contactors. It has to be taken into account that for a certain motor, torque and current curves are fixed, independently of the load, for constant voltage.

In cases where motor starting current is high, this can cause interference to the following:

- a) Significant voltage drop in the power supply feeding system. As a consequence, other equipment connected to the same system can suffer interference.
- b) The protection system (cables and contactors) must be oversized leading to a high cost.
- c) Power supply utilities will limit the supply voltage drop.

In cases where DOL starting is not feasible due to above given reasons, then indirect system can be used in order to reduce the starting current such as:

- Star-delta starting
- Starting with compensating switch (auto-transformer starting)
- Series-parallel starting
- Electronic starting (soft-start)

STAR-DELTA STARTING

It is fundamental for star-delta starting that three phase motor have the required number of leads to allow connection on both voltages, that is, 220/380V, 380/660V or 440/760V.

These motors should have at least 6 connecting leads. The starting has to be made at no load. The star-delta starting can be used when the motor torque curve is sufficiently high to guarantee acceleration of the load at reduced voltage. At star connection, current is reduced to 25% to 30% of the starting current in comparison to delta connection.

Torque curve is also reduced proportionally. For this reason, every time a star-delta starting is required, a high torque curve motor must be used.

WEG motors have high starting and breakdown torque. Hence, they are suitable in most cases for star-delta starting.

The load resistant torque can not exceed the motor starting torque, neither the current when switching to delta connection can not be of an unacceptable value.

There are cases where this starting method can not be used. For example, when the resistant torque is too high. If the starting is made at star, motor will accelerate the load up to approximately 85% of the rated speed. In this point, the switch must be connected at delta. In this case, the current which is about the rated current jumps, suddenly, which is in fact not advantageous, as the purpose is to reduce the starting current.

Table 5 shows the most common multiple rated voltages for three phase motors and their use to the usual power supply voltages.

The DOL or compensating switch starting is applicable to all cases of table 5.





TABLE 5

Normal connections for three phase motors		
Winding design	Operation Voltage	Star-delta starting
220V/380V	220 V 380 V	yes
		no
220/440/230/460	220V/230V 440V/760V	no
		yes
380V/660V	380V	yes
220/380/440/760	220V 380V 440V	yes
		no
		yes

STARTING WITH COMPENSATING SWITCH (AUTO-TRANSFORMER)

This starting method can be used to start motors hooked to the load. It reduces the starting current avoiding in this way overload giving the motor enough torque for the starting and acceleration. The voltage in the compensating switch is reduced through an auto-transformer which normally has TAPS of 50, 65 and 80% of the rated voltage.

SERIES - PARALLEL STARTING

For series-parallel starting, motor must allow reconnection for two voltages:

The lowest to be equal to the power supply voltage and the other twice higher.

This starting method requires 9 connecting leads in the motor, and the most common voltage is 220/440V, that is, during the starting, motor is series connected until it reaches the rated speed and then it is switched to parallel connection.

ELECTRONIC STARTING (SOFT START)

The advance of the electronics has allowed creation of the solid state starting switch which is composed of a set of pairs of tiristors (SCR) (or combination of tiristors/diodes), one on each motor output borne.

The trigger angle of each pair of tiristors is controlled electronically to apply a variable voltage to the motor terminals during the acceleration. At the final moment of the starting, typically adjusted between 2 and 30 seconds, voltage reaches its full load value after a smooth acceleration or an increasing ramp, instead of being submitted to increasing or sudden jumps.

Due to that it is possible to keep the starting current (in the power supply) close to the rated current and with slight variation.

Besides the advantage of controlling the voltage (current) during the starting, the electronic switch has also the advantage of not having moving parts or those that generate arc, as it happens with mechanical switches. This is a strong point of the electronic switches as their useful life is extended.

3.2.3 - MOTOR PROTECTION

Motors in continuous use should be protected from overloads by means of a device incorporated into the motor, or by an independent device, usually a fixed or adjustable thermal relay equal or less than to the value originated from the multiplication of the rated feed current at full load by:

- 1.25 for motors with a service factor equal or superior to 1.15; or
- 1.15 for motors with service factor equal to 1.0 (IEC 34)

Some motors are optionally fitted with overheating protective devices such as thermoresistances, thermistors, thermostats or thermal protectors.

The type of temperature detector to be used are selected taking into consideration the motor insulation temperature, type of motor and customer requirement.

THERMOSTAT (THERMAL PROBE)

They are bimetallic thermal detectors with normally closed silver contacts. They open as the temperature increases and then return to the original position as soon as the temperature acting on the bimetallic decreases, allowing new closing of the contacts.

Thermostats can be used for alarm, tripping systems or both (alarm and tripping) of three phase electric motors when requested by the customer. Thermostats are series connected directly to the contactor coil circuit.

Depending on the safety level and customer requirement, three thermostats (one per phase) or six thermostats (two per phase) can be installed. In order to operate as alarm and tripping (two thermostats per phase), the alarm thermostats must be suitable to act at the motor predetermined temperature, while the tripping thermostats must act at the maximum temperature of the insulating material.

Thermostats are also used on special applications of single phase motors. On these applications, the thermostat can be series connected with the motor power supply as long as the motor current does not exceed the maximum acceptable current of the thermostat.

If this occurs, connect the thermostat in series with the contactor coil.

Thermostats are installed in the coil heads of different phases.

THERMISTORS (PTC and NTC)

These are semi-conductor heat detectors which sharply change their resistance upon reading a set temperature.

PTC - Positive temperature coeficient.

NTC - Negative temperature coeficient.

The PTC type is a thermistor whose resistance increases sharply to a temperature defined value specified for each type. This sudden variation of the resistance interrupts the current in the PTC by acting an outlet relay which switches off the main circuit. It can also be used for alarm and tripping systems (two per phase).

NTC thermistors, which act adversily of PTC's, are not normally used on WEG motors as the control electronic circuits available commonly apply to PTC's.

Thermistors have reduced size, do not suffer mechanical wear and act quicker in relation to other temperature detectors.

Fitted with control electronic circuits, thermistors give complete protection for overheating, overload, sub or overvoltages or frequent reversing or on - off operations.

It is a low cost device, similar to a PT-100, but it requires a commanding relay for alarm or operation.

RESISTANCE TEMPERATURE DETECTORS (RTD) PT-100

The RTD operates on the principle that the electrical resistance of a metallic conductor varies linearly with the temperature. It is an element usually made of copper, platinum or nickel which allows a continuous follow up of the motor heating process through a control panel of high precision and acting sensibility. Highly used in the industry in general where temperature measuring and automation techniques are required. Also widely used on applications that require irregular intermittent duty.

A single detector can be used for alarm and tripping purposes.

THERMAL PROTECTORS

These are bimetallic thermal detectors with normally closed silver contacts. Mainly used as protection of single phase motors against overheating caused by overloads, locked rotor, voltage drop, etc. They are normally fitted in the motors when requested by the customer. The basic components are a bimetallic disc, two flexible contacts, a resistance and a pair of fixed contacts.

It is series connected with the supply voltage and, due to a thermal dissipation caused by the current pass through its internal resistance, the disc is deformed enough to open the contacts, and then motor feeding is interrupted. As soon as the temperature comes down, the protector should react.

Based on the resetting, there are two types of thermal protectors:

- a) Automatic overload protector where the resetting is done automatically.



b) Manual overload protector when the resetting is done through a manual release.

Table 6 shows a comparison between motor protection systems.

TABLE 6

COMPARISON BETWEEN MOTOR PROTECTION SYSTEMS			
Causes of overheating	Current-based protection		Protection with probe thermistor in motor
	Fuse only	Fuse and thermal protector	
Overload with 1.2 times rated current	○	●	●
Duty cycles S1 to S10	○	◐	●
Brakings, reversals and frequent starts	○	◐	●
Operation with more than 15 starts p/hour	○	◐	●
Locked rotor	◐	◐	●
Fault on one phase	○	◐	●
Excessive voltage fluctuation	○	●	●
Frequency fluctuation on main supply	○	●	●
Excessive ambient temperature	○	●	●
External heating caused by bearings, belts, pulleys, etc.	○	○	●
Obstructed ventilation	○	○	●

CAPTION ○ Unprotected
 ◐ Partially protected
 ● Totally protected

3.3 - START-UP

3.3.1 - PRELIMINARY INSPECTION

Before starting a motor for the first time, check the following:

- Remove all locking devices and blocks used in transit and check that the motor rotates freely;
- Check if the motor is firmly secured and that coupling elements are correctly mounted and aligned;
- Ascertain that voltage and frequency correspond to those indicated on the nameplate. Motor performance will be satisfactory as long as voltage and frequency remain in the range determined by IEC Standard.
- Check if connections are in accordance with the connection diagram shown on the nameplate and be sure that all terminal screws and nuts are tight;

e) Check the motor for proper grounding. Providing that there are no specifications calling for ground-insulated installation, the motor must be grounded in accordance with prevalent standard for grounding electrical machines. The screw identified by the symbol (⏚) should be used for this purpose. This screw is generally to be found in the terminal box or on the motor foot.

f) Check if motor leads correspond with the main supply as well as the control wires, and the overload protection device are in accordance with IEC Standards;

g) If the motor has been stored in a humid place, or has been stopped for some time, measure the insulating resistance as recommended under the item covering storage instructions;

h) Start the motor uncoupled to ascertain that it is running freely and in the desired direction.

To reverse the rotation of a three-phase motor, invert two terminal leads of the main power supply.

Medium voltage motors having an arrow on the frame indicating rotation direction can only turn in the direction shown;

3.3.2 - THE FIRST START-UP

THREE-PHASE MOTOR WITH SQUIRREL CAGE ROTOR

After careful checking of the motor, follow the normal sequence of starting operations listed in the control instructions for the initial start-up.

BEARING SPECIFICATION BY MOTOR TYPE

TABLE 7

FRAMES	Mounting Config.	BEARINGS	
		DE	ODE
TEFC motors			
63	all mounting configurations	6201-ZZ	6201-ZZ
71		6203-ZZ	6202-ZZ
80		6204-ZZ	6203-ZZ
90 S		6205-ZZ	6204-ZZ
90 L		6205-ZZ	6204-ZZ
100 L		6206-ZZ	6205-ZZ
112 M		6307-ZZ	6206-ZZ
132 S		6308-ZZ	6207-ZZ
132 M		6308-ZZ	6207-ZZ
160 M		6309-Z-C3	6209-Z-C3
160 L		6309-Z-C3	6209-Z-C3
180 M		6311-Z-C3	6211-Z-C3
180 L		6311-Z-C3	6211-Z-C3
200 L		6312-Z-C3	6212-Z-C3
200 M		6312-Z-C3	6212-Z-C3
225 S/M		6314-C3	6314-C3
250 S/M		6314-C3	6314-C3
280 S/M		6314-C3**	6314-C3
		6316-C3	6316-C3
315 S/M		6314-C3**	6314-C3
	6319-C3	6316-C3	
355 M/L	6314-C3	6314-C3	
	NU322-C3	6319-C3	

** Only valid for 2 pole motors.



3.3.3 - OPERATION

Drive the motor coupled to the load for a period of at least one hour while watching for abnormal noises or signs of overheating. Compare the line current with the value shown on the nameplate. Under continuous running conditions without load fluctuations, this should not exceed the rated current times the service factor, also shown on the nameplate.

All measuring and control instruments and apparatus should be continuously checked for any deviation and any irregularities corrected.

3.3.4 - STOPPING

Warning:

To touch any moving part of a running motor, even though disconnected, is a danger to life and limb.

Three-phase motor with squirrel cage rotor:
Open the stator circuits switch. With the motor at a complete stop, reset the auto-transformer, if any, to the "start" position.

BEARING SPECIFICATION BY MOTOR TYPE

TABLE 8

FRAMES	Mounting Config.	BEARINGS	
		DE	ODE
TEFC motors			
143 T	all mounting configurations	6205-ZZ	6204-ZZ
145 T		6205-ZZ	6204-ZZ
182 T		6307-ZZ	6206-ZZ
184 T		6307-ZZ	6206-ZZ
213 T		6308-ZZ	6207-ZZ
215 T		6308-ZZ	6207-ZZ
254 T		6309-C3	6209-C3
256 T		6309-C3	6209-C3
284 T/TS		6311-C3	6211-C3
286 T/TS		6311-C3	6211-C3
324 T/TS		6312-C3	6212-C3
326 T/TS		6312-C3	6212-C3
364 T/TS		6314-C3	6314-C3
365 T/TS		6314-C3	6314-C3
404 T		6314-C3	6314-C3
405 TS		6314-C3	6314-C3
444 T		6316-C3	6316-C3
444 TS		6314-C3**	6314-C3
445 T		6316-C3	6316-C3
445 TS		6314-C3**	6314-C3
504 Z	6319-C3	6316-C3	
505 U	6314-C3**	6314-C3	
505 Z	6319-C3	6316-C3	
586 T	6314-C3	6314-C3	
587 T	NU 322-C3	6319-C3	

** Only valid for 2 pole motors.

BEARING SPECIFICATION BY MOTOR TYPE

BEARINGS FOR SAW ARBOR MOTORS

TABLE 8A

SAW ARBOR	Mounting Config.	BEARINGS	
		DE	ODE
80 S MS	B 3	6307-ZZ	6207-ZZ
80 M MS		6307-ZZ	6207-ZZ
80 L MS		6307-ZZ	6207-ZZ
90 L MS		6308-ZZ	6208-ZZ

NEMA FRAME MOTORS

TABLE 8B

NEMA Frames	Mounting Config.	BEARINGS	
		DE	ODE
ODP motors			
48B	all mounting configurations	6203-ZZ	6202-ZZ
56 A		6203-ZZ	6202-ZZ
56 B		6203-ZZ	6202-ZZ
56 D		6204-ZZ	6202-ZZ
56 H		6204-ZZ	6202-ZZ



TABLE 9
BEARING LUBRICATION INTERVALS AND AMOUNT OF GREASE

1. SINGLE-ROW FIXED BALL BEARINGS										
BEARING CHARACTERISTICS		LUBRICATION INTERVALS (Running hours)								Amount of grease (g)
		II POLE		IV POLE		VI POLE		VIII POLE		
		60 Hz	50 Hz	60 Hz	50 Hz	60 Hz	50 Hz	60 Hz	50 Hz	
S E R I E S	6200	12500	13800							2
	6201	11700	13000	16600	18400					2
	6202	10500	11900	15400	17100	19500				2
	6203	9800	11200	14500	16200	18500				3
	6204	8700	10100	13300	14800	17100	19100			4
	6205	8000	9400	12600	14100	16200	18200	19300		4
	6206	7300	8700	12000	13400	15400	17200	18300		5
	6207	6600	8100	11400	12700	14500	16300	17300	19200	7
	6208	5900	7400	10800	12000	13700	15300	16300	18200	8
	6209	5300	6900	10400	11600	13400	15000	16000	17800	8
	6210	4900	6400	9700	11000	12900	14600	15600	17300	9
	6211	4300	5900	9500	10900	12700	14400	15300	17000	11
	6212	3800	5400	9300	10300	12400	14300	15200	16500	13
	6213	3100	4900	8900	10100	12200	14000	14800	16100	14
6214*	1100	2000	4100	5000	5900	6500	6900	7600	15	
6215*	1000	1800	4400	5000	5600	6300	6700	7600	17	
6216*	700	1600	4100	4700	5700	6500	6800	7500	19	

NOTE: The table above is intended for lubrication intervals at 70°C bearing temperature. For 15°C above 70°C, the lubrication interval is reduced to half. The intervals given above are not valid for special applications and / or special grease.
* Bearing lubrication intervals considering bearing temperature at 85°C.





**TABLE 9.1
BEARING LUBRICATION AND AMOUNT OF GREASE**

SINGLE-ROW FIXED BALL BEARINGS														
Bearing Characteristics	LUBRICATION INTERVALS												Amount of grease (g)	
	II Pole		IV Pole		VI Pole		VIII Pole		X Pole		XII Pole			
	60 Hz	50 Hz	60 Hz	50 Hz	60 Hz	50 Hz	60 Hz	50 Hz	60 Hz	50 Hz	60 Hz	50 Hz		
63 SERIES	6304	8700	10100	13300	14800	17100	19100							4
	6305	8000	9400	12600	14100	16200	18200	19300						6
	6306	7300	8700	12000	13400	15400	17200	18300						7
	6307	6600	8100	11400	12700	14500	16300	17300	19200					9
	6308	5900	7400	10800	12000	13700	15300	16300	18200	18600				11
	6309	5300	6900	10400	11600	13400	15000	16000	17800	18200	19900			13
	6310	4900	6400	9700	11000	12900	14600	19500	17300	17700	19500	19500		15
	6311	4300	5900	9500	10900	12700	14400	15300	17000	17400	19000	19000		18
	6312	3800	5400	9300	10300	12400	14300	15200	16500	16800	18200	18200		21
	6313	3100	4900	8900	10100	12200	14000	14800	16100	16400	17900	17900	19700	24
	6314	1100	2000	4100	5000	5900	6500	6900	7600	7700	8600	8600	9600	27
	6315	1000	1800	4400	5000	5600	6300	6700	7600	7900	8900	8900	9900	30
	6316	700	1600	4100	4700	5700	6500	6800	7500	7700	8500	8500	9500	34
	6317	800	1300	3900	4700	5600	6300	6700	7400	7500	8300	8300	9300	37
	6318	-----	1000	3800	4600	5500	6200	6600	7200	7400	8200	8200	9100	41
	6319	-----	800	3700	4500	5400	6100	6500	7100	7300	8000	8000	8900	45
6320	-----	-----	3600	4300	5300	6000	6300	7000	7100	7900	7900	8800	51	
6321	-----	-----	3400	4200	5100	5800	6200	6800	7000	7800	7800	8700	56	
6322	-----	-----	3100	4000	5000	5700	6100	6700	6900	7700	7700	8600	60	

**TABLE 10
BEARING LUBRICATION INTERVALS AND AMOUNT OF GREASE**

ROLLER BEARINGS														
Bearing Characteristics	LUBRICATION INTERVALS (Running hours)												Amount of grease (g)	
	II Pole		IV Pole		VI Pole		VIII Pole		X Pole		XII Pole			
Designation	60 Hz	50 Hz	60 Hz	50 Hz	60 Hz	50 Hz	60 Hz	50 Hz	60 Hz	50 Hz	60 Hz	50 Hz	60 Hz	50 Hz
NU3 SERIES	NU309	2800	4000	8300	9500	10700	11800	12500	14100	14500	16300	16300	18200	13
	NU310	2400	3600	7900	9100	10300	11400	12200	13700	14000	15800	15800	17700	15
	NU311	2000	3200	7400	8700	10000	11000	11800	13300	13600	15400	15400	17200	18
	NU312	1600	2700	6900	8300	9600	10700	11400	12800	13200	14900	14900	16800	21
	NU313	1500	2500	6600	8100	9400	10500	11200	12700	13000	14700	14700	16500	24
	NU314	700	1100	3100	3900	4600	5200	5500	6200	6400	7200	7200	8100	27
	NU315	-----	900	2900	3800	4500	5100	5500	6200	6300	7100	7100	7900	30
	NU316	-----	800	2800	3600	4400	5000	5400	6100	6200	7000	7000	7800	34
	NU317	-----	600	2600	3500	4300	4900	5300	6000	6100	6900	6900	7700	37
	NU318	-----	-----	2100	3300	4300	4900	5300	5900	6000	6700	6700	7500	41
	NU319	-----	-----	2300	3200	4100	4700	900	5800	6000	6700	6700	7500	45
	NU320	-----	-----	2000	3000	4000	4700	5000	5700	5900	6600	6600	7300	51
	NU321	-----	-----	1900	2800	4000	4600	4900	5600	5700	6500	6500	7200	56
	NU322	-----	-----	1900	2600	3900	4400	4800	5500	5600	6400	6400	7100	60





4 - MAINTENANCE

A well-designed maintenance program for electric motors, when correctly used, can be summed up as: periodical inspection of insulation levels, temperature rise, wear, bearing lubrication at the occasional checking of fan air flow. Inspection cycles depend upon the type of motor and the conditions under which it operates.

4.1 - CLEANLINESS

Motors should be kept clean, free of dust, debris and oil. Soft brushes or clean cotton rags should be used for cleaning. A jet of compressed air should be used to remove non-abrasive dust from the fan cover and any accumulated grime from the fan and cooling fins. Terminal boxes fitted to motors with IP-55 protection should be cleaned; their terminals should be free of oxidation, in perfect mechanical condition, and all unused space dust-free. Motors with IP(W) 55 protection are recommended for use under unfavourable ambient conditions.

4.2 - LUBRICATION

Motors made up to frame 160 are not fitted with grease fitting, while larger frames up to frame 200 this device is optional. For frame 225 to 355 grease fitting is supplied as standard. Proper Lubrication extends bearing life. Lubrication Maintenance Includes:

- a) Attention to the overall state of the bearings;
- b) Cleaning and lubrication;
- c) Careful inspection of the bearings.

Bearing temperature control is also part of routine maintenance. The temperature of bearings lubricated with suitable grease as recommended under item 4.2.2 should not exceed 70°C. Constant temperature control is possible with the aid of external thermometers or by embedded thermal elements. WEG motors are normally equipped with grease lubricated ball or roller bearings. Bearings should be lubricated to avoid the metallic contact of the moving parts, and also for protection against corrosion and wear. Lubricant properties deteriorate in the course of time and mechanical operation and, furthermore, all lubricants are subject to contamination under working conditions. For this reason, lubricants must be renewed and any lubricant consumed needs replacing from time to time.

4.2.1 - LUBRICATION INTERVALS

To apply correct amount of grease is an important aspect for a good lubrication.

Relubrication must be made based on the relubrication intervals Table. However, when a motor is fitted with a lubrication instructions plate, these instructions must be followed.

For an efficient initial bearing lubrication, the motor manual or the Lubrication Table must be followed. If this information is not available, the bearing must be greased up to its half (only the empty space between the moving parts).

When performing these tasks, care and cleanliness are recommended in order to avoid penetration of dust into the bearings.

4.2.2 - QUALITY AND QUANTITY OF GREASE

Correct lubrication is important!

Grease must be applied correctly and in sufficient quantity as both insufficient or excessive greasing are harmful.

Excessive greasing causes overheating brought about by the greater resistance caused on the rotating parts and, in particular, by the compacting of the lubricant and its eventual loss of lubricating qualities.

This can cause seepage with the grease penetrating the motor and dripping on the coils or other motor components.

A lithium based grease is commonly used for the lubrication of electric motor bearings as it has good mechanical stability, insoluble in water.

Greases for standard motors

Type	Supplier	Frame
Unirex	Esso	160M/L to 355M/L
Alvânia R3	Shell	Other Frames

Greases for special feature motors

Type	Temp. (°C)
Alvânia R3	(-30 to 135)
UNIREX N2	(-30 to 165)
BG 20	(-45 to 180)

This grease should never be mixed with different base greases. More details about the greases mentioned above can be obtained at an authorized service agent or you can contact WEG directly.

4.2.3. LUBRICATION INSTRUCTIONS

- Inject about half the estimated amount of grease and run the motor at full speed for approximately a minute; switch off the motor and inject the remaining grease.

The injection of all the grease with the motor at rest could cause penetration of a portion of the lubricant through the internal seal of the bearing case and hence into the motor.

Nipples must be clean prior to introduction of grease to avoid entry of any alien bodies into the bearing.

For lubricating, use only a manual grease gun.

BEARING LUBRICATION STEPS

1. Clean the area around the grease nipples with clean cotton fabric.
2. With the motor running, add grease with a manual grease gun until the quantity of grease recommended in Tables 9 or 10 has been applied.
3. Allow the motor to run long enough to eject all excess of grease.

4.2.4 - REPLACEMENT OF BEARINGS

The opening of a motor to replace a bearing should only be carried out by qualified personnel.

Damage to the core after the removal of the bearing cover is avoided by filling the gap between the rotor and the stator with stiff paper of a proper thickness.

Providing suitable tooling is employed, disassembly of a bearing is not difficult (Bearing Extractor).

The extractor grips should be applied to the sidewall of the inner ring to the stripped, or to an adjacent part.

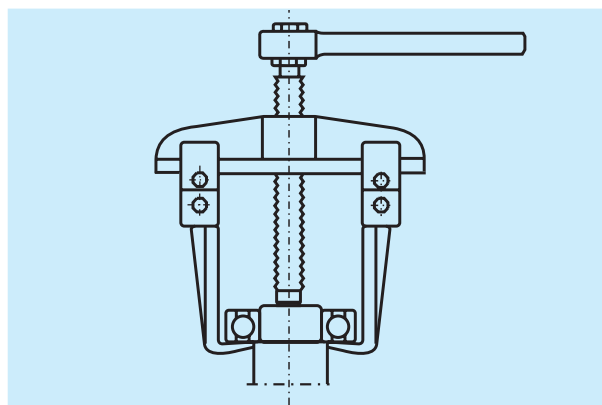

Fig. 4.2 - Bearing Extractor

To ensure perfect functioning and no injury to the bearing parts, it is essential that the assembly be undertaken under conditions of





complete cleanliness and by competent personnel.
 New bearings should not be removed from their packages until the moment of assembly.
 Prior to fitting a new bearing, ascertain that the shaft has no rough edges or signs of hammering.
 During assembly bearings cannot be subjected to direct blows. The aid used to press or strike the bearing should be applied to the inner ring.
 Protect all machined parts against oxidation by applying a coating of vaseline or oil immediately after cleaning.

STRIPPING OF WINDINGS - This step requires great care to avoid knocking and/or denting of enclosure joints and, when removing the sealing compound from the terminal box, damage or cracking of the frame.

IMPREGNATION - Protect all frame threads by using appropriate bolts, and terminal box support fitting with a non-adhesive varnish (ISO 287 - ISOLASIL).
 Protective varnish on machined parts should be removed soon after treating with impregnation varnish. This operation should be carried out manually without using tools.

ASSEMBLY - Inspect all parts for defects, such as cracks, joint incrustations, damaged threads and other potential problems.
 Assemble using a rubber headed mallet and a bronze bushing after ascertaining that all parts are perfect by fitted.
 Bolts should be positioned with corresponding spring washers and evenly tightened.

TESTING - Rotate the shaft by hand while examining for any drag problems on covers or fastening rings.

MOUNTING THE TERMINAL BOX - Prior to fitting the terminal box all cable outlet on the frame should be sealed with a self extinguishable sponge compound (1st layer) and on Explosion Proof Motors an Epoxy resin (ISO 340) mixed with ground quartz (2nd layer).

Drying time for this mixture is two hours during which the frame should not be handled and cable outlets should be upwards.
 When dry, see that the outlets and areas around the cables are perfectly sealed.
 Mount the terminal box and paint the motor.

4.3- MISCELLANEOUS RECOMMENDATIONS

- Any damaged parts (cracks, pittings in machined surfaces, defective threads) must be replaced and under no circumstances should attempt be made to recover them.
- Upon reassembling explosion proof motors IP(W) 55, the replacement of all seals is mandatory.

SINGLE PHASE MOTORS

SINGLE PHASE ASYNCHRONOUS INDUCTION MOTORS:

ADVANTAGES:
 WEG single phase motors, totally enclosed fan cooled (degree of protection IP55) are highly resistant to bad weather, any external contamination and action and penetration of rodents, and they offer more additional advantages in relation to standard motors.
 The capacitors - start and run-supply superior power factor and high efficiency, offering significant energy saving.
 The energy saving obtained by using this new single phase motors can be calculated comparing the efficiency and power factor curves in order to know the investment payback.
 These motors are built with an efficient starting method. The centrifugal switch mounted on a rigid base is fitted with special steel helicoidal springs, resistant to fatigue, driven by counter-weights designed in such a way to ensure the closing and opening under minimum and maximum established speeds.

FRACTIONAL MOTORS

FRACTIONAL ODP NEMA 48 AND 56 MOTORS:

SINGLE PHASE: Built with high starting torque which are suitable for heavy loads.
 They are supplied with starting capacitor.

APPLICATIONS: Compressors, pumps, industrial air conditioning equipment, general machines and tooling, other industrial and commercial components requiring high starting torque.

THREE PHASE: Designed with torque suitable to drive industrial machines as well as optimized breakdown torques to operate under instantaneous overload conditions.

APPLICATIONS: Compressors, pumps, fans, chippers and general use machines powered by three phase network and continuous duty.

THREE PHASE ODP FRACTIONAL MOTOR "JET PUMP"

This type of motor can be used where three phase power supply is applicable. It has high starting torque, and breakdown torque approximately 3 times the rated current.

FRACTIONAL ODP "JET PUMP" MOTOR - START CAPACITOR

It is a single phase motor designed with a main winding and a capacitor series connected with the auxiliary winding.
 The centrifugal switch disconnects the auxiliary winding when motor reaches about 80% of the synchronous speed. Then the motor operates continuously with the main winding.
 The start capacitor motors present high torques. The starting torque varies between 200 and 350% of the rated torque, and the breakdown torque between 200% and 300% of the rated torque.
 Based on these features, this type of motor is recommended for heavy starting load and it is used for the range of output up to 3HP (2.2kW).

APPLICATIONS: Water pumping systems by jet pumps, commercial and industrial pumps, domestic use pumps, centrifugal pumps and hydraulic pumps.

FRACTIONAL ODP MOTOR "JET PUMP PLUS" - SPLIT PHASE

It is a single phase motor built with two windings: main and starting auxiliary. The centrifugal switch disconnects the auxiliary winding when the motor reaches about 70% of the synchronous speed. Then the motor operates continuously with the main winding.
 The "Jet Pump Plus - Split Phase" has moderated torques. The starting torque varies between 150% and 200% of the rated torque, and the breakdown torque between 200% and 300% of the rated torque.
 It is a type of motor recommended for applications that require few starts and low starting torque.

These are the mechanical characteristics for this line of motors:

- Squirrel cage rotor
- Ball bearings
- 1045 steel shaft or stainless steel (optional)
- Feet and thermal protector (optional)
- CCW rotation direction
- Voltages: single-phase: 110V, 220V or 110/220V
 split-phase: without capacitor
- Standard painting is Red Oxid Primer.
- Degree of Protection is IP21.



THREE PHASE MOTOR - PREMIUM HIGH EFFICIENCY

Standard Features:

- Frequency: 60Hz and 50Hz
- Voltages: 220/380V, 380/660V, 440/760V or 220/380/440V
- Service Factor: 1.0
- Class of insulation: "F"
- Degree of Protection: IP55
- Design N (IEC 85)
- Speeds: 60Hz: 3600, 1800, 1200 and 900 rpm
50Hz: 3000, 1500, 1000 and 750 rpm
- Temperature rise: below 80°C

Optional Features:

- Class of insulation: "H"
- Degree of Protection: IP(W)55
- Thermal protection: Thermostats or thermistors
- Space heaters
- Routine and type test (IEC 34-2), witnessed or not.

Optional Features on Request:

- Design: H
- Hazardous location motors
- Explosion proof motors
- Increased safety
- Marine duty motors

THREE PHASE BRAKE MOTORS - Single Disc

GENERAL DESCRIPTION:

The brake motor is composed of an induction motor coupled to a single disc brake forming an integral and compact unit. The induction motor is a totally enclosed fan cooled motor with the same mechanical and electrical performance of the WEG standard motors.

The brake is built with few movable parts which gives long life with reduced maintenance. The two faces of the brake pads create a large contact area which reduces the pressure over them, reduces the heating and the wear is minimum.

Besides, the brake is cooled by the same motor cooling.

The electromagnet drive coil, protected with epoxy resin, operates continuously with voltages varying 10% above and below the rated voltage. It is DC powered, supplied by a bridge rectifier made of silicon diodes and varistors which avoid sudden voltage peaks and allow a quick current switching off.

The DC power supply gives the brake a quicker and uniform operation.

APPLICATIONS:

Brake motors are commonly used on: tooling-machines, sewing machines, packing machines, conveyors, bottle washing machines, winding machines, folding machines, hoists, rolling bridges, elevators, printing machines and others. In general terms, on equipment requiring quick stops based on safety, positioning and time saving factors.

BRAKE OPERATION:

When motor is switched off from power supply, the control also interrupts the coil current and then the electromagnet stops operating. The pressure springs force the armature towards the motor non drive endshield. The braking pads, which are fitted in the braking disc, are compressed between the two friction surfaces, the armature and the endshield braking the motor until it stops.

The armature is pulled against the electromagnet frame by eliminating the spring resistance. Once they are free, the braking pads move axially in their fittings and they stay out of the friction area.

In this way, the braking is finished permitting the motor to start freely.

As an option, WEG can supply lining braking disc.

INSTALLATION:

Brake motors can be mounted in any position as long as it is not subject to penetration of water, oil, abrasive dust, etc through the air inlet.

When normally mounted, the brake motor complies with Degree of Protection IP54 of IEC.

CONNECTION DIAGRAM

The WEG Brakemotor allows 3 types of connection diagram supplying slow, medium and quick brakings.

a) Slow Braking

The feeding of the brake coil bridge rectifier is done directly from the motor terminals, without interruption, as shown below:

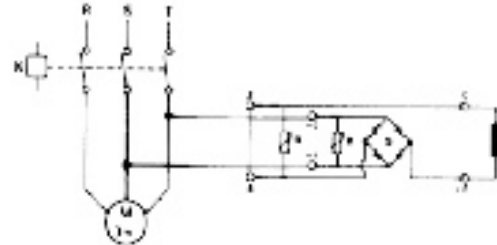

- D - Bridge rectifier
- R - Varistors
- L - Electromagnet coil
- K - Contactor

Fig. 1 - Connection diagram for slow braking

b) Medium Braking:

In this case a contact for interruption of the bridge rectifier feeding current in the AC circuit is fitted. It is essential that this be a NO auxiliary contact of the contactor itself or motor magnetic switch in order to allow switch on and off of brake and motor simultaneously.

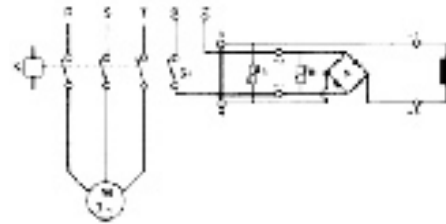

- D- Bridge rectifier
- R- Varistors
- L- Electromagnet coil
- K- Contactor
- S1- NO auxiliary contact.

Fig 2 - Connection diagram for medium braking.

c) Quick Braking:

A contact for interruption is directly fitted in one of the coil feeding cables in the DC circuit.

It is essential that this is a NO auxiliary contact of the contactor itself or motor magnetic switch.

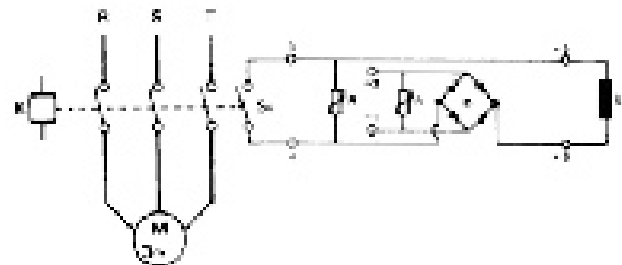

- D - Bridge rectifier
- R - Varistors
- L - Electromagnet coil
- K - Contactor
- S1 - NO auxiliary contact

Fig. 3 - Connection Diagram for quick braking.



BRAKE COIL FEEDING:

The medium and quick braking allow two feeding alternatives:

a) Through motor terminals:

Motor 220/380V: Connect motor terminals 2 and 6 to terminals 1 and 2 of the bridge rectifier.

Motor 220/380/440/760V: connect motor terminals 1 and 4 to terminals 1 and 2 of the bridge rectifier.

Two speed motor 220V.

- High Speed: Connect motor terminals 4 and 6 to terminals 1 and 2 of the bridge rectifier.
- Low Speed: Connect motor terminals 1 and 2 to terminals 1 and 2 of the bridge rectifier.
- Motor 440V: Connect two of the motor terminals to terminals 1 and 2 of the bridge rectifier.

b) Independent Feeding:

For motor built for other voltages, connect the brake coil terminals to the independent 24ADC power supply. However, always with simultaneous interruption with motor feeding. With independent feeding it is possible to electrically release the brake, as shown in Fig. 4.

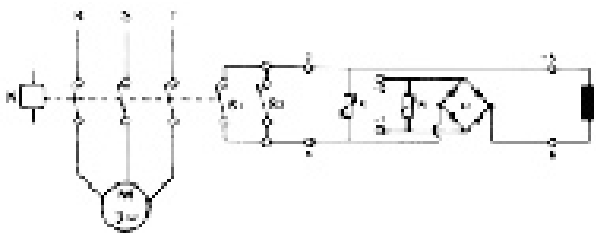

D - Bridge rectifier
R - Varistors
L - Electromagnet coil
K - Contactor
S1 - NO auxiliary contact
S2 - Electric release switch

Fig. 4 - Connection Diagram for independent feeding.

BRAKING TORQUE

It is possible to obtain a smoother motor stop by reducing the braking torque value. This is done by removing the brake pressure springs.

IMPORTANT:

The springs must be removed in such a way the remaining ones stay symmetrically disposed, avoiding in this way any friction even after operating the motor, and uneven wear of the braking pads.

BRAKE MAINTENANCE

As they are of simple construction, brake motors require low maintenance. What it is required to do is a periodical airgap adjustment.

It is recommended to clean internally the brake motor in cases of penetration of water, dust, etc. or at the time motor periodical maintenance is carried out.

AIRGAP ADJUSTMENT

WEG brake motors are supplied with an initial factory set air gap, that is, a gap between the armature and the frame with the brake energized, pre-adjusted at the factory to the minimum value as

indicated in Table 1.

TABLE 1

FRAME	Initial (factory set) Air gap (mm)	Maximum air gap (mm)
71	0.2 - 0.3	0.6
80	0.2 - 0.3	0.6
90 S - 90 L	0.2 - 0.3	0.6
100 L	0.2 - 0.3	0.6
112 M	0.2 - 0.3	0.6
132 S - 132 M	0.3 - 0.4	0.8
160M - 160L	0,3 - 0,4	0,8

Due to the natural wear of the braking pads, the size of the air gap gradually increases without affecting the performance of the brake until it reaches the maximum value shown on Table 1.

To adjust the air gap to its initial value, proceed as follows:

- a - Unfasten the bolts and remove the fan cover
- b - Remove the protective band
- c - Measure the air gap in three places, near the adjustment screws, using a set of feeler gauges.
- d - If the width of the gap is equal to or greater than the maximum indicated, or if the three readings are not the same, proceed to adjust as follows:
 - 1) Loosen the fixing bolts and the adjustment screws.
 - 2) Adjust the air gap to the initial value indicated in Table 1 by equally adjusting the three adjustment screws.
The value of the air gap must be uniform at the three measured points, and be such that the feeler gauge corresponding to the minimum gap, moves freely and the feeler gauge corresponding to the maximum gap cannot be introduced to any of the measured points.
 - 3) Adjust the adjustment screws until the ends touch the motor endshield. Do not adjust any further.
 - 4) Tighten the fixing bolts.
 - 5) Re-check the air gap to ensure the measurements are as per Point 2 above.
 - 6) Replace the protective band.
 - 7) Replace the fan cover

Periodical Inspection and Re-adjustment of the air gap

The time interval between periodical adjustments of the air gap, that is, the number of braking operations until the wear of pads leads the air gap to its maximum value depends on the load, the frequency of operations, and the condition of the working environment, etc. The ideal interval can only be determined by closely observing the performance of the brake motor during the first months of its operating under actual working conditions. As a guide, Table 2 indicates the typical values which can be expected under normal working conditions. The wear of the brake linings depends on the moment of inertia of the load.

EXPLOSION PROOF MOTORS

The motors are designed to operate in ambients considered as dangerous.

These are areas where inflammable gases, steams or combustible gas are or can be in the environment continuous, intermittent or periodically in amount enough to produce explosive mixture or inflammable originated from seepage, repairs or maintenance.

Due to this, the design and manufacturing criteria of the motor components are differentiated from standard motor lines, specially in reference to mechanical aspects.

This motor line follows the recommendations of the following standards: ABNT (Brazilian Association of Technical Standards), IEC (International Electrical Code), UL (Underwriters Laboratories Inc.), CSA (Canadian Standards Association).

The special features of an explosion proof motor are the following:

- Mechanical resistance strong enough to withstand the impact of an internal explosion.
- Dimensional geometric tolerances and controlled rugosity level to avoid passage of flames to the outside and to control the amount of





gases exchanged between inside and outside of the motor.
Below you will find an explanation of the features which make a motor to become explosion proof:

CONSTRUCTION FEATURES:

The features described above, by themselves, do not guarantee that the motor meets the Standard specifications. Then suitable

MECHANICAL RESISTANCE	<ul style="list-style-type: none"> - Cast iron rugged construction (walls are thicker); corrosion resistant. - Fixation of endshields made with tempered internally hexangled bolts, with high resistance to traction. - More bolts to fix the endshield
TIGHTNESS	<ul style="list-style-type: none"> - Use of epoxy base sealing compound between frame and terminal box - Fitting between endshields and frame with larger dimensions in comparison to standard motors, as per IEC 34-7 Standard. - Use of an internal DE and NDE bearing cap. - Touching surface between T-box and frame and T-box and endshield are machined (which does not require rubber sealing ring).

procedures and tools are required.
Therefore, explosion proof motors can not be assembled or serviced by personnel not authorized.

WARNING:

The operation place of an electric explosion proof motor is harmful to life.





5 - ABNORMAL SITUATIONS DURING OPERATION

ANALYSIS OF SOME ABNORMAL SITUATIONS AND POSSIBLE CAUSES ON ELECTRIC MOTORS:

ABNORMAL SITUATION	POSSIBLE CAUSES
MOTOR DOES NOT START	<ul style="list-style-type: none"> - Lack of voltage on motor terminals - Low feeding voltage - Wrong connection - Incorrect numbering of leads - Excessive load - Open stationary switch - Damaged capacitor - Auxiliary coil interrupted
LOW STARTING TORQUE	<ul style="list-style-type: none"> - Incorrect internal connection - Failed rotor - Rotor out of center - Voltage below the rated voltage - Frequency below the rated frequency - Frequency above the rated frequency - Capacitance below that specified - Capacitors series connected instead of parallel
LOW BREAKDOWN TORQUE	<ul style="list-style-type: none"> - Failed rotor - Rotor with bar inclination above that specified - Rotor out of center - Voltage below the rated voltage - Run capacitor below that specified
HIGH NO LOAD CURRENT	<ul style="list-style-type: none"> - Air gap above that specified - Voltage above that specified - Frequency below that specified - Wrong internal connection - Rotor out of center - Rotor rubbing on the stator - Defective bearing - Endbells fitted under pressure or badly fitted - Steel magnetic lamination without treatment - Run capacitor out of that specified - Stationary/centrifugal switch do not open
HIGH CURRENT UNDER LOAD	<ul style="list-style-type: none"> - Voltage out of the rated voltage - Overload - Frequency out of the rated frequency - Belts excessively tightened - Rotor rubbing on the stator
LOW INSULATION RESISTANCE	<ul style="list-style-type: none"> - Damaged slot insulating materials - Cut leads - Coil head touching the motor frame - Humidity or chemical agents present - Dust on the winding





ABNORMAL SITUATION	POSSIBLE CAUSES
BEARING HEATING	<ul style="list-style-type: none"> - Excessive amount of grease - Excessive axial thrust or radial force of the belt - Bent shaft - Loose endbells or out of center - Lack of grease - Foreign bodies in the grease
MOTOR OVERHEATING	<ul style="list-style-type: none"> - Obstructed ventilation - Smaller size fan - Voltage or frequency out of that specified - Rotor rubbing on the shaft - Failed rotor - Stator with insufficient impregnation - Overload - Defective bearing - Consecutive starts - Air gap below that specified - Improper run capacitor - Wrong connections
HIGH NOISE LEVEL	<ul style="list-style-type: none"> - Unbalancing - Bent shaft - Incorrect alignment - Rotor out of center - Wrong connections - Foreign bodies in the air gap - Foreign bodies between fan and fan cover - Worn bearings - Improper slots combination - Inadequate aerodynamic
EXCESSIVE VIBRATION	<ul style="list-style-type: none"> - Rotor out of center - Unbalance power supply voltage - Failed rotor - Wrong connections - Unbalanced rotor - Bearing housing with excessive clearance - Rotor rubbing on the stator - Bent shaft - Stator laminations loose - Use of fractional groups on run capacitor single-phase winding





SERVICE

Leaving the factory in perfect conditions is not enough for the electric motor. Although the high quality standard assured by Weg for several years of operation, there will be a day when the motor will require service: This can be corrective, preventive or orientative.

Weg gives great importance to service as this makes part of a successful sale.

Weg service is immediate and efficient.

At the moment you buy a Weg electric motor, you are also receiving an incomparable know-how developed in the company and you will count on our authorized services during the whole motor operating life, carefully selected and strategically located in more than fifty countries.



1-800-ASK-4WEG

*Tru-Metric*TM

NEW



- ✓ Multi-Frequency 60/50Hz
- ✓ EPACT Efficiency
- ✓ Aluminum frame with removable feet (63 up 132M)
- ✓ Cast Iron frame (63 up to 355M/L)

The Better Alternative





Tru-Metric™ - TEFC (IP55) High Efficiency - IEC Metric Frame

Suitable for
Inverter Duty

IEC
60Hz/50Hz

NEW

This line is designed and built according to European IEC 34 and IEC 79 Standards. The enclosure IP55 TEFC is ideal for indoor and outdoor applications. These motors are tested according to IEEE 112 std., method 'B' and their efficiency values are certified according to EPACT regulations (CC029A).

Standard Features

- EPACT CC# CC029A
- 3 phase, 50/60Hz, 380-415V (50Hz); 230/460V (60Hz)
- Aluminum with removable feet (63 up to 132M frames)
- Cast iron (63 up to 355M/L frames)
- Squirrel cage rotor / Aluminum die cast
- Enclosure TEFC (IP55)
- Oil Seal on both endshields
- Class 'F' insulation
- Service Factor: 1.15 in 60Hz
1.0 in 50Hz
- Temperature rise: Class 'B' (80°C)
- Continuous duty (S1)
- 104°F (40°C) ambient temperature
- Altitude: 3300 ft (1000 m)
- Stainless steel nameplate on both aluminum and cast iron frames
- Finish painting: Synthetic enamel alkyd resin base
- Color: Dark Gray (RAL 7022)
- Grease relief system in frame 225 S/M and above
- Thermistors (1 per phase) fitted in frames 225 S/M and above
- Drilled and tapped shaft
- Automatic drain plug
- Standard mouting: F-2 (B3R)
Also available in F-1 (B3L) and F-0 (B3T)



Applications

- Blowers
- Compressors
- Pumps
- Conveyor
- Textiles
- Marine Duty
- Other

**WEG is a world-wide
supplier of electric motors.
WEG IEC metric frame
motors have TRUE METRIC
FRAME dimensions!**

Optional Features

- Terminal block
- Flanges
- Class 'H' insulation
- Taconite labyrinth seal
- Cable glands
- Space heaters
- Double shaft end
- Thermistors
- Thermostats or RTD's (PT100)
- Regreasing system for frames 160M up to 200
- Drip cover (canopy) for shaft down applications
- Special painting plan for hostile environments
- Roller bearings on drive end

APPROVED BY



E 104590

APPROVED BY



LR 38324



Tru-Metric™ - TEFC (IP55)

High Efficiency - IEC Metric Frame

Suitable for
Inverter Duty

IEC
60Hz/50Hz



EPACT CC# CC0294A

kW	HP	RPM 60Hz / 50Hz	IEC Frame	Catalog Number	Frame Material	List Price	Eff. @ FL (60Hz)	Volts
								60Hz / 50Hz
0.18	0.25	3600 / 3000	63	.1836EP3EAL63	AL	194	68.0	230/460V / 380-415V
		3600 / 3000	63	.1836EP3E63	CI	194	68.0	230/460V / 380-415V
		1800 / 1500	63	.1818EP3EAL63	AL	185	69.0	230/460V / 380-415V
		1800 / 1500	63	.1818EP3E63	CI	185	69.0	230/460V / 380-415V
		1200 / 1000	71	.1812EP3EAL71	AL	234	61.0	230/460V / 380-415V
		1200 / 1000	71	.1812EP3E71	CI	234	61.0	230/460V / 380-415V
		900 / 750	80	.1809EP3EAL80	AL	374	50.5	230/460V / 380-415V
		900 / 750	80	.1809EP3E80	CI	374	50.5	230/460V / 380-415V
0.25	0.33	3600 / 3000	63	.2536EP3EAL63	AL	198	70.0	230/460V / 380-415V
		3600 / 3000	63	.2536EP3E63	CI	198	70.0	230/460V / 380-415V
		1800 / 1500	71	.2518EP3EAL71	AL	195	73.0	230/460V / 380-415V
		1800 / 1500	71	.2518EP3E71	CI	195	73.0	230/460V / 380-415V
		1000 / 1200	71	.2512EP3EAL71	AL	252	64.0	230/460V / 380-415V
		1000 / 1200	71	.2512EP3E71	CI	252	64.0	230/460V / 380-415V
		900 / 750	80	.2509EP3EAL80	AL	404	57.5	230/460V / 380-415V
		900 / 750	80	.2509EP3E80	CI	404	57.5	230/460V / 380-415V
0.37	0.50	3600 / 3000	71	.3736EP3EAL71	AL	214	73.0	230/460V / 380-415V
		3600 / 3000	71	.3736EP3E71	CI	214	73.0	230/460V / 380-415V
		1800 / 1500	71	.3718EP3EAL71	AL	201	73.0	230/460V / 380-415V
		1800 / 1500	71	.3718EP3E71	CI	201	73.0	230/460V / 380-415V
		1000 / 1200	80	.3712EP3EAL80	AL	262	64.0	230/460V / 380-415V
		1000 / 1200	80	.3712EP3E80	CI	262	64.0	230/460V / 380-415V
		900 / 750	90 S	.3709EP3EAL90S	AL	459	61.5	230/460V / 380-415V
		900 / 750	90 S	.3709EP3E90S	CI	459	61.5	230/460V / 380-415V
0.55	0.75	3600 / 3000	71	.5536EP3EAL71	AL	219	76.0	230/460V / 380-415V
		3600 / 3000	71	.5536EP3E71	CI	219	76.0	230/460V / 380-415V
		1800 / 1500	80	.5518EP3EAL80	AL	231	77.0	230/460V / 380-415V
		1800 / 1500	80	.5518EP3E80	CI	231	77.0	230/460V / 380-415V
		1000 / 1200	80	.5512EP3EAL80	AL	281	66.0	230/460V / 380-415V
		1000 / 1200	80	.5512EP3E80	CI	281	66.0	230/460V / 380-415V
		900 / 750	90 L	.5509EP3EAL90L	AL	483	62.5	230/460V / 380-415V
		900 / 750	90 L	.5509EP3E90L	CI	483	62.5	230/460V / 380-415V
0.75	1	3600 / 3000	80	.7536EP3EAL80	AL	239	79.0	230/460V / 380-415V
		3600 / 3000	80	.7536EP3E80	CI	239	79.0	230/460V / 380-415V
		1800 / 1500	80	.7518EP3EAL80	AL	235	80.0	230/460V / 380-415V
		1800 / 1500	80	.7518EP3E80	CI	235	80.0	230/460V / 380-415V
		1000 / 1200	90 S	.7512EP3EAL90S	AL	313	80.0	230/460V / 380-415V
		1000 / 1200	90 S	.7512EP3E90S	CI	313	80.0	230/460V / 380-415V
		900 / 750	100 L	.7509EP3EAL100L	AL	524	74.0	230/460V / 380-415V
		900 / 750	100 L	.7509EP3E100L	CI	524	74.0	230/460V / 380-415V
1.1	1.5	3600 / 3000	80	00136EP3EAL80	AL	256	82.5	230/460V / 380-415V
		3600 / 3000	80	00136EP3E80	CI	256	82.5	230/460V / 380-415V
		1800 / 1500	90 S	00118EP3EAL90S	AL	284	84.0	230/460V / 380-415V
		1800 / 1500	90 S	00118EP3E90S	CI	284	84.0	230/460V / 380-415V
		1000 / 1200	90 L	00112EP3EAL90L	AL	450	78.5	230/460V / 380-415V
		1000 / 1200	90 L	00112EP3E90L	CI	450	78.5	230/460V / 380-415V
		900 / 750	100 L	00109EP3EAL100L	AL	532	77.0	230/460V / 380-415V
		900 / 750	100 L	00109EP3E100L	CI	532	77.0	230/460V / 380-415V
1.5	2	3600 / 3000	90 S	00156EP3EAL90S	AL	304	84.0	230/460V / 380-415V
		3600 / 3000	90 S	00156EP3E90S	CI	304	84.0	230/460V / 380-415V
		1800 / 1500	90 L	00158EP3EAL90L	AL	316	84.0	230/460V / 380-415V
		1800 / 1500	90 L	00158EP3E90L	CI	316	84.0	230/460V / 380-415V
		1000 / 1200	100 L	00152EP3EAL100L	AL	489	81.5	230/460V / 380-415V
		1000 / 1200	100 L	00152EP3E100L	CI	489	81.5	230/460V / 380-415V
		900 / 750	112 M	00159EP3EAL112M	AL	604	82.5	230/460V / 380-415V
		900 / 750	112 M	00159EP3E112M	CI	604	82.5	230/460V / 380-415V

AL = Aluminum frame
CI = Cast Iron frame



Tru-Metric™ - TEFC (IP55)

High Efficiency - IEC Metric Frame

Suitable for
Inverter Duty

IEC
60Hz/50Hz

EPACT CC# CC0294A

kW	HP	RPM 60Hz / 50Hz	IEC Frame	Catalog Number	Frame Material	List Price	Eff. @ FL (60Hz)	Volts 60Hz / 50Hz		
2.2	3	3600 / 3000	90 L	00236EP3EAL90L	AL	456	85.5	230/460V / 380-415V		
		3600 / 3000	90 L	00236EP3E90L	CI	456	85.5	230/460V / 380-415V		
		1800 / 1500	100 L	00218EP3EAL100L	AL	380	87.5	230/460V / 380-415V		
		1800 / 1500	100 L	00218EP3E100L	CI	380	87.5	230/460V / 380-415V		
		1000 / 1200	112 M	00212EP3EAL112M	AL	674	86.5	230/460V / 380-415V		
		1000 / 1200	112 M	00212EP3E112M	CI	674	86.5	230/460V / 380-415V		
		900 / 750	132 S	00209EP3EAL132S	AL	852	84.0	230/460V / 380-415V		
		900 / 750	132 S	00209EP3E132S	CI	852	84.0	230/460V / 380-415V		
3	4	3600 / 3000	100 L	00336EP3EAL100L	AL	486	84.0	230/460V / 380-415V		
		3600 / 3000	100 L	00336EP3E100L	CI	486	84.0	230/460V / 380-415V		
		1800 / 1500	100 L	00318EP3EAL100L	AL	405	87.5	230/460V / 380-415V		
		1800 / 1500	100 L	00318EP3E100L	CI	405	87.5	230/460V / 380-415V		
		1000 / 1200	132 S	00312EP3AL132S	AL	721	87.5	230/460V / 380-415V		
		1000 / 1200	132 S	00312EP3132S	CI	721	87.5	230/460V / 380-415V		
		900 / 750	132 M	00309EP3EAL132M	AL	971	84.0	230/460V / 380-415V		
		900 / 750	132 M	00309EP3E132M	CI	971	84.0	230/460V / 380-415V		
4	5.5	3600 / 3000	112 M	00436EP3EAL112M	AL	527	87.5	230/460V / 380-415V		
		3600 / 3000	112 M	00436EP3E112M	CI	527	87.5	230/460V / 380-415V		
		1800 / 1500	112 M	00418EP3EAL112M	AL	455	89.5	230/460V / 380-415V		
		1800 / 1500	112 M	00418EP3E112M	CI	455	89.5	230/460V / 380-415V		
		1000 / 1200	132 M	00412EP3EAL132M	AL	756	87.5	230/460V / 380-415V		
		1000 / 1200	132 M	00412EP3E132M	CI	756	87.5	230/460V / 380-415V		
		900 / 750	160 M	00409EP3E160M	CI	1,175	85.5	230/460V / 380-415V		
		5.5	7.5	3600 / 3000	132 S	00536EP3EAL132S	AL	690	88.5	230/460V / 380-415V
3600 / 3000	132 S			00536EP3E132S	CI	690	88.5	230/460V / 380-415V		
1800 / 1500	132 S			00518EP3EAL132S	AL	625	89.5	230/460V / 380-415V		
1800 / 1500	132 S			00518EP3E132S	CI	625	89.5	230/460V / 380-415V		
1000 / 1200	132 M			00512EP3EAL132M	AL	1,043	87.5	230/460V / 380-415V		
1000 / 1200	132 M			00512EP3E132M	CI	1,043	87.5	230/460V / 380-415V		
900 / 750	160 M			00509EP3E160M	CI	1,354	85.5	230/460V / 380-415V		
7.5	10			3600 / 3000	132 S	00736EP3EAL132S	AL	779	89.5	230/460V / 380-415V
		3600 / 3000	132 S	00736EP3E132S	CI	779	89.5	230/460V / 380-415V		
		1800 / 1500	132 M	00718EP3EAL132M	AL	744	89.5	230/460V / 380-415V		
		1800 / 1500	132 M	00718EP3E132M	CI	744	89.5	230/460V / 380-415V		
		1000 / 1200	160 M	00712EP3E160M	CI	1,360	89.5	230/460V / 380-415V		
		900 / 750	160 L	00709EP3E160L	CI	1,674	88.5	230/460V / 380-415V		
		11	15	3600 / 3000	160 M	01136EP3E160M	CI	1,240	90.2	230/460V / 380-415V
				1800 / 1500	160 M	01118EP3E160M	CI	1,071	91.0	230/460V / 380-415V
1000 / 1200	160 L			01112EP3E160L	CI	1,864	90.2	230/460V / 380-415V		
900 / 750	180 L			01109EP3E180L	CI	2,432	89.5	230/460V / 380-415V		
15	20			3600 / 3000	160 M	01518EP3E160M	CI	1,423	90.2	230/460V / 380-415V
				1800 / 1500	160 L	01518EP3E160L	CI	1,315	91.0	230/460V / 380-415V
				1000 / 1200	180 L	01512EP3E180L	CI	2,291	92.0	230/460V / 380-415V
				900 / 750	200 L	01509EP3E200L	CI	3,112	89.5	230/460V / 380-415V
		18.5	25	3600 / 3000	160 L	01836EP3E160L	CI	1,725	91.0	230/460V / 380-415V
				1800 / 1500	180 M	01818EP3E180M	CI	1,670	92.4	230/460V / 380-415V
				1000 / 1200	200 L	01812EP3E200L	CI	2,882	91.7	230/460V / 380-415V
				900 / 750	225 S/M	01809EP3E225S/M	CI	3,657	91.7	230/460V / 380-415V
22	30			3600 / 3000	180 M	02236EP3E180M	CI	2,059	91.0	230/460V / 380-415V
				1800 / 1500	180 L	02218EP3E180L	CI	2,003	92.4	230/460V / 380-415V
				1000 / 1200	200 L	02212EP3E200L	CI	2,904	92.4	230/460V / 380-415V
				900 / 750	225 S/M	02209EP3E225S/M	CI	4,651	92.4	230/460V / 380-415V
		30	40	3600 / 3000	200 L	03036EP3E200L	CI	2,876	92.4	230/460V / 380-415V
				1800 / 1500	200 L	03018EP3E200L	CI	2,749	93.0	230/460V / 380-415V
				1000 / 1200	225 S/M	03012EP3E225S/M	CI	4,680	93.0	230/460V / 380-415V
				900 / 750	250 S/M	03009EP3E250S/M	CI	5,488	93.0	230/460V / 380-415V

AL = Aluminum frame
CI = Cast Iron frame

Tru-Metric™ - TEFC (IP55)

High Efficiency - IEC Metric Frame

Suitable for
Inverter Duty

IEC
60Hz/50Hz



EPACT CC# CC0294A

kW	HP	RPM 60Hz / 50Hz	IEC Frame	Catalog Number	Frame Material	List Price	Eff. @ FL (60Hz)	Volts 60Hz / 50Hz
37	50	3600 / 3000	200 L	03736EP3E200L	CI	3,236	92.4	230/460V / 380-415V
		1800 / 1500	225 S/M	03718EP3E225S/M	CI	4,119	93.0	230/460V / 380-415V
		1000 / 1200	250 S/M	03712EP3E250S/M	CI	6,055	93.0	230/460V / 380-415V
		900 / 750	280 S/M	03709EP3E280S/M	CI	7,281	92.4	230/460V / 380-415V
45	60	3600 / 3000	225 S/M	04536EP3E225S/M	CI	4,696	93.0	230/460V / 380-415V
		1800 / 1500	225 S/M	04518EP3E225S/M	CI	4,360	93.6	230/460V / 380-415V
		1000 / 1200	280 S/M	04512EP3E280S/M	CI	6,710	94.1	460V / 380-415V
		900 / 750	280 S/M	04509EP3E280S/M	CI	7,940	94.1	460V / 380-415V
55	75	3600 / 3000	250 S/M	05536EP3E250S/M	CI	5,811	93.0	230/460V / 380-415V
		1800 / 1500	250 S/M	05518EP3E250S/M	CI	5,286	94.1	230/460V / 380-415V
		1000 / 1200	280 S/M	05512EP3E280S/M	CI	7,670	94.5	460V / 380-415V
		900 / 750	315 S/M	05509EP3E315S/M	CI	9,529	94.5	460V / 380-415V
75	100	3600 / 3000	280 S/M	07536EP3E280S/M	CI	7,357	93.6	460V / 380-415V
		3600 / 3000	280 S/M	07536EP3G280S/M	CI	7,357	93.6	460V / 380-415V
		1800 / 1500	280 S/M	07518EP3E280S/M	CI	7,287	94.5	460V / 380-415V
		1800 / 1500	280 S/M	07518EP3G280S/M	CI	7,287	94.5	460V / 380-415V
		1000 / 1200	315 S/M	07512EP3E315S/M	CI	9,720	95.0	460V / 380-415V
		1000 / 1200	315 S/M	07512EP3G315S/M	CI	9,720	95.0	460V / 380-415V
		900 / 750	315 S/M	07509EP3E315S/M	CI	11,554	93.0	460V / 380-415V
		900 / 750	315 S/M	07509EP3G315S/M	CI	11,554	93.0	460V / 380-415V
90	125	3600 / 3000	280 S/M	09036EP3G280S/M	CI	9,863	94.5	460V / 380-415V
		1800 / 1500	280 S/M	09018EP3G280S/M	CI	8,978	94.5	460V / 380-415V
		1200 / 1000	315 S/M	09012EP3G315S/M	CI	11,472	95.0	460V / 380-415V
		900 / 750	315 S/M	09009EP3G315S/M	CI	13,190	95.4	460V / 380-415V
110	150	3600 / 3000	315 S/M	11036EP3G315S/M	CI	12,398	94.5	460V / 380-415V
		1800 / 1500	280 S/M	11018EP3G280S/M	CI	9,754	95.0	460V / 380-415V
		1200 / 1000	315 S/M	11012EP3G315S/M	CI	12,564	95.0	460V / 380-415V
		900 / 750	355 M/L	11009EP3G355M/L	CI	17,294	94.1	460V / 380-415V
132	175	3600 / 3000	315 S/M	13236EP3G315S/M	CI	13,674	94.5	460V / 380-415V
		1800 / 1500	315 S/M	13218EP3G315S/M	CI	11,639	95.0	460V / 380-415V
		1200 / 1000	355 M/L	13212EP3G355M/L	CI	16,874	95.0	460V / 380-415V
		900 / 750	355 M/L	13209EP3G355M/L	CI	20,874	94.1	460V / 380-415V
150	200	3600 / 3000	315 S/M	15036EP3G315S/M	CI	15,484	95.0	460V / 380-415V
		1800 / 1500	315 S/M	15018EP3G315S/M	CI	12,843	95.0	460V / 380-415V
		1200 / 1000	355 M/L	15012EP3G355M/L	CI	19,764	95.0	460V / 380-415V
		900 / 750	355 M/L	15009EP3G355M/L	CI	26,589	94.1	460V / 380-415V
185	250	3600 / 3000	315 S/M	18536EP3G315S/M	CI	16,438	95.4	460V / 380-415V
		1800 / 1500	315 S/M	18518EP3G315S/M	CI	16,263	95.0	460V / 380-415V
		1200 / 1000	355 M/L	18512EP3G355M/L	CI	26,964	95.0	460V / 380-415V
		900 / 750	355 M/L	18509EP3G355M/L	CI	28,594	94.5	460V / 380-415V
220	300	3600 / 3000	355 M/L	22036EP3G355M/L	CI	27,395	95.4	460V / 380-415V
		1800 / 1500	355 M/L	22018EP3G355M/L	CI	22,452	95.4	460V / 380-415V
		1200 / 1000	355 M/L	22012EP3G355M/L	CI	28,467	95.0	460V / 380-415V
		900 / 750	355 M/L	22009EP3G355M/L	CI	35,883	94.5	460V / 380-415V
260	350	3600 / 3000	355 M/L	26036EP3G355M/L	CI	31,377	95.4	460V / 380-415V
		1800 / 1500	355 M/L	26018EP3G355M/L	CI	27,115	95.4	460V / 380-415V
		1200 / 1000	355 M/L	26012EP3G355M/L	CI	32,841	95.0	460V / 380-415V
300	400	1800 / 1500	355 M/L	30018EP3G355M/L	CI	29,722	95.4	460V / 380-415V
		1200 / 1000	355 M/L	30012EP3G355M/L	CI	37,359	95.0	460V / 380-415V
330	450	1200 / 1000	355 M/L	33012EP3G355M/L	CI	40,002	95.0	460V / 380-415V

AL = Aluminum frame
C I = Cast Iron frame



Tru-Metric™ - TEFC (IP55)

High Efficiency - IEC Metric Frame

Suitable for
Inverter Duty

IEC
60Hz / 50Hz

Electrical Data - 60Hz - 460V

Rated Output		Rated Speed rpm	IEC Frame	Full Load Current In A		LRC FLC	Locked Rotor Current kVA code	Full Load Torque Tn Lb.Ft	Locked Rotor Torque TI/Tn	Break-Down Torque Tb/Tn	Efficiency η %			Power Factor Cos φ			Service Factor SF	Moment of Inertia Wk ² Lb.Ft ²	Allowable Locked Rotor Time Hot/Cold (s)	Approx. Weight Lb
kW	HP			At 230V	At 460V						% of full load									
											50	75	100	50	75	100				
0.18	0.25	3310	63	0.96	0.48	5.0	J	0.38	3.0	3.1	58.0	65.0	68.0	0.48	0.60	0.70	1.15	0.00285	20/44	8
		1710	63	1.02	0.51	4.6	J	0.74	2.8	2.9	63.0	67.0	69.0	0.42	0.54	0.64	1.15	0.01329	19/42	10
		1100	71	1.54	0.77	3.5	K	1.15	2.8	2.8	49.0	57.0	61.0	0.31	0.40	0.48	1.15	0.01875	15/33	13
		860	80	1.60	0.80	3.3	K	1.48	2.0	2.4	34.6	43.3	50.5	0.40	0.48	0.56	1.15	0.05743	8/18	19
0.25	0.33	3350	63	1.24	0.62	5.4	K	0.53	3.3	3.4	62.0	67.0	70.0	0.50	0.62	0.72	1.15	0.00380	22/48	10
		1710	71	1.36	0.68	5.0	K	1.03	3.1	3.4	66.0	71.0	73.0	0.42	0.54	0.63	1.15	0.01875	32/70	13
		1100	71	2.00	1.00	3.5	K	1.60	2.8	2.8	53.0	62.0	64.0	0.31	0.41	0.49	1.15	0.02278	11/24	15
		845	80	1.74	0.87	3.4	J	2.09	1.7	2.0	47.2	54.3	57.5	0.43	0.54	0.63	1.15	0.06977	10/22	21
0.37	0.5	3420	71	1.66	0.83	5.5	J	0.76	3.1	3.3	67.0	72.0	73.0	0.56	0.68	0.77	1.15	0.00783	23/51	12
		1710	71	2.12	1.06	5.0	K	1.52	3.4	3.6	65.0	71.0	73.0	0.38	0.51	0.60	1.15	0.01875	36/79	13
		1135	80	2.14	1.07	5.0	K	2.30	2.9	3.0	57.0	63.0	64.0	0.48	0.60	0.68	1.15	0.05743	16/35	18
		840	90 S	2.70	1.35	4.4	L	3.10	2.3	2.5	56.5	62.0	61.5	0.36	0.46	0.56	1.15	0.10631	12/26	33
0.55	0.75	3420	71	2.28	1.14	5.7	H	1.13	3.2	3.2	72.0	75.0	76.0	0.60	0.72	0.80	1.15	0.01068	16/35	15
		1740	80	2.50	1.25	7.5	L	2.23	3.2	3.6	72.0	76.5	77.0	0.50	0.63	0.72	1.15	0.05743	10/22	20
		1135	80	3.26	1.63	5.2	L	3.42	3.3	3.2	56.5	63.0	66.0	0.44	0.55	0.64	1.15	0.07380	9/20	23
		845	90 L	4.24	2.12	4.0	L	4.59	2.7	2.9	56.4	62.2	62.5	0.33	0.43	0.52	1.15	0.14618	11/24	37
0.75	1	3400	80	2.84	1.42	6.0	H	1.55	2.9	3.1	76.0	79.0	79.0	0.69	0.79	0.84	1.15	0.01875	18/40	20
		1730	80	3.02	1.51	7.4	K	3.06	3.1	3.4	76.2	79.0	80.0	0.55	0.69	0.78	1.15	0.06977	8/18	23
		1145	90 S	3.42	1.71	5.4	J	4.62	2.6	2.7	77.8	80.0	80.0	0.47	0.60	0.69	1.15	0.14618	22/48	53
		865	100 L	4.62	2.31	4.6	K	6.11	1.6	2.4	70.0	72.0	74.0	0.37	0.46	0.55	1.15	0.26601	16/35	49
1.1	1.5	3410	80	4.14	2.07	7.2	J	2.27	3.7	3.7	79.0	80.5	82.5	0.61	0.73	0.81	1.15	0.02278	10/22	22
		1745	90 S	4.32	2.16	7.6	K	4.44	2.9	3.5	80.0	82.5	84.0	0.55	0.67	0.76	1.15	0.11960	10/22	31
		1145	90 L	5.50	2.75	5.6	K	6.77	3.2	3.0	74.5	78.0	78.5	0.42	0.55	0.64	1.15	0.15947	8/18	40
		860	100 L	6.52	3.26	4.2	J	9.01	1.7	2.4	72.0	75.5	77.0	0.37	0.47	0.55	1.15	0.34575	18/40	75
1.5	2	3480	90 S	5.40	2.70	9.1	L	3.04	3.8	3.7	81.5	83.7	84.0	0.65	0.76	0.83	1.15	0.04865	10/22	32
		1755	90 L	5.98	2.99	8.8	M	6.02	3.5	4.0	81.5	84.0	84.0	0.53	0.65	0.75	1.15	0.15947	9/20	40
		1160	100 L	7.46	3.73	6.1	L	9.11	2.7	3.3	77.0	80.0	81.5	0.41	0.52	0.62	1.15	0.34575	25/55	66
		870	112 M	8.16	4.08	5.7	L	12.2	3.5	3.8	77.0	80.0	82.5	0.35	0.47	0.56	1.15	0.57664	17/37	77
2.2	3	3490	90 L	8.28	4.14	9.9	M	4.44	4.2	4.4	82.7	84.5	85.5	0.57	0.70	0.78	1.15	0.05743	6/13	33
		1745	100 L	8.88	4.44	9.0	M	8.89	4.9	5.4	84.0	86.5	87.5	0.49	0.63	0.71	1.15	0.29069	10/22	71
		1165	112 M	9.38	4.69	8.0	L	13.3	3.4	3.5	84.0	86.5	86.5	0.45	0.58	0.68	1.15	0.62101	16/35	99
		875	132 S	9.40	4.70	7.4	L	17.7	2.5	2.7	82.5	84.0	84.0	0.50	0.62	0.70	1.15	1.78616	20/44	132
3	4	3505	100 L	10.4	5.21	9.0	L	6.03	3.5	4.0	80.0	82.5	84.0	0.71	0.81	0.86	1.15	0.14618	8/18	55
		1740	100 L	11.8	5.89	9.7	N	12.2	4.6	4.9	84.0	86.5	87.5	0.51	0.65	0.73	1.15	0.29069	10/22	71
		1175	132 S	13.7	6.83	8.1	M	18.0	2.7	3.4	84.0	86.5	87.5	0.42	0.54	0.63	1.15	1.37990	20/44	146
		870	132 M	12.8	6.40	7.1	L	24.3	2.4	2.6	82.5	84.0	84.0	0.49	0.61	0.70	1.15	2.02441	19/42	154
3.7	5	3495	112 M	13.7	6.83	9.5	L	8.07	3.0	4.2	84.0	86.5	87.5	0.69	0.79	0.84	1.15	0.19981	10/22	71
		1755	112 M	14.4	7.19	7.6	J	16.1	2.3	3.1	88.5	89.5	89.5	0.59	0.71	0.78	1.15	0.44494	12/26	90
		1170	132 M	16.9	8.44	7.7	L	24.1	2.4	3.2	85.5	87.5	87.5	0.48	0.60	0.68	1.15	1.37990	20/44	174
		880	160 M	19.3	9.63	5.4	J	32.0	2.5	2.9	82.5	85.5	85.5	0.40	0.52	0.61	1.15	2.89720	24/53	243
5.5	7.5	3535	132 S	17.9	8.97	9.2	K	11.0	3.0	3.8	84.0	87.5	88.5	0.72	0.82	0.87	1.15	0.57664	15/33	110
		1770	132 S	18.6	9.29	10.0	L	21.9	2.6	3.5	87.5	89.5	89.5	0.64	0.76	0.83	1.15	1.28783	9/20	88
		1170	132 M	22.6	11.3	7.2	K	33.1	2.1	2.8	85.5	87.5	87.5	0.50	0.63	0.70	1.15	1.56381	11/24	154
		880	160 M	27.0	13.5	5.5	J	44.0	2.8	3.0	82.5	85.5	85.5	0.38	0.50	0.60	1.15	3.40858	20/44	278
7.5	10	3535	132 S	24.8	12.4	9.4	L	15.0	3.0	3.9	85.5	88.5	89.5	0.69	0.80	0.85	1.15	0.57664	8/18	110
		1765	132 M	25.4	12.7	9.5	L	29.9	2.6	3.5	88.5	89.5	89.5	0.63	0.75	0.83	1.15	1.56381	8/18	148
		1175	160 M	28.4	14.2	7.0	J	45.0	3.0	3.5	87.5	89.5	89.5	0.51	0.65	0.74	1.15	3.40858	16/35	276
		880	160 L	30.4	15.2	5.4	H	60.1	2.0	2.2	85.5	87.5	88.5	0.50	0.62	0.70	1.15	4.43110	15/33	320
11	15	3560	160 M	37.8	18.9	10.2	M	21.8	3.4	4.8	84.0	90.2	90.2	0.63	0.75	0.81	1.15	1.25650	12/26	243
		1765	160 M	40.0	20.0	7.0	J	43.9	3.2	3.2	87.5	90.2	91.0	0.56	0.69	0.76	1.15	2.38178	19/42	276
		1175	160 L	43.2	21.6	7.5	K	66.0	3.4	3.8	87.5	89.5	90.2	0.48	0.62	0.71	1.15	4.17529	12/26	300
		885	180 L	40.6	20.3	9.0	L	87.6	2.6	3.0	87.5	88.5	89.5	0.57	0.69	0.76	1.15	7.19897	10/22	404
15	20	3550	160 M	50.2	25.1	8.9	K	29.8	2.9	4.0	88.5	90.2	90.2	0.66	0.77	0.83	1.15	1.25650	11/24	243
		1765	160 L	53.8	26.9	6.7	J	59.9	3.0	3.0	88.5	90.2	91.0	0.58	0.70	0.77	1.15	2.73892	11/24	287
		1175	180 L	47.0	23.5	9.0	K	90.0	2.8	3.8	91.7	92.4	92.0	0.71	0.82	0.87	1.15	8.18068	12/26	459
		880	200 L	61.8	30.9	5.0	G	120	2.1	2.1	87.5	86.5	89.5	0.48	0.61	0.68	1.15	8.93909	33/73	496
18.5	25	3555	160 L	60.0	30.0	9.9	L	36.7	3.1	4.1	89.5	91.0	91.0	0.71	0.81	0.85	1.15	1.53557	11/24	287
		1770	180 M	63.6	31.8	8.5	K	73.7	3.4	3.2	90.2	91.7	92.4	0.60	0.73	0.79	1.15	4.68264	12/26	386
		1180	200 L	63.4	31.7	6.6	H	110	2.4	2.4	91.0	92.4	91.7	0.63	0.76	0.80	1.15	8.93909	25/55	494
		885	225S/M	61.8	30.9	7.8	J													



Electrical Data - 60Hz - 460V

Rated Output		Rated Speed rpm	IEC Frame	Full Load Current In A		LRC FLC	Locked Rotor Current kVA code	Full Load Torque Tn Lb.Ft	Locked Rotor Torque TI/Tn	Break-Down Torque Tb/Tn	Efficiency η %			Power Factor Cos φ			Service Factor SF	Moment of Inertia Wk² Lb.Ft²	Allowable Locked Rotor Time Hot/Cold (s)	Approx. Weight Lb
kW	HP			At 230V	At 460V						% of full load									
											50	75	100	50	75	100				
22	30	3555	180 M	71.4	35.7	9.5	L	43.6	2.8	3.7	89.5	91.0	91.0	0.74	0.82	0.85	1.15	2.82838	9/20	397
		1770	180 L	73.8	36.9	8.7	K	87.6	3.5	3.2	91.0	92.4	92.4	0.65	0.76	0.81	1.15	5.53407	11/24	430
		1180	200 L	74.8	37.4	7.0	H	131	2.5	2.4	91.0	92.4	92.4	0.63	0.76	0.80	1.15	10.64200	20/44	562
		885	225S/M	74.8	37.4	8.5	K	175	2.1	3.2	91.0	92.4	92.4	0.60	0.73	0.80	1.15	23.45520	15/33	805
30	40	3575	200 L	97.0	48.5	8.4	K	59.1	3.2	3.5	90.2	91.7	92.4	0.72	0.80	0.84	1.15	4.89550	13/29	540
		1780	200 L	102	51.2	7.8	J	119	2.8	2.8	91.7	93.0	93.0	0.65	0.75	0.79	1.15	7.85344	18/40	529
		1185	225S/M	101	50.6	8.0	K	178	3.1	3.5	90.2	91.7	93.0	0.60	0.73	0.80	1.15	23.45520	18/40	807
		885	250S/M	101	50.6	8.5	K	239	2.2	3.2	92.4	93.0	93.0	0.63	0.75	0.80	1.15	29.04010	16/35	970
37	50	3570	200 L	118	59.1	8.5	K	73.0	3.8	3.4	91.2	92.4	92.4	0.73	0.81	0.85	1.15	5.32122	18/40	573
		1780	225S/M	116	58.1	7.4	H	146	2.6	3.0	91.7	93.0	93.0	0.72	0.82	0.86	1.15	16.60790	14/31	893
		1185	250S/M	122	60.9	8.0	J	220	3.2	3.4	91.0	92.4	93.0	0.68	0.78	0.82	1.15	31.27380	20/44	992
		895	280S/M	129	64.4	8.0	K	291	2.0	2.5	91.7	92.4	92.4	0.63	0.73	0.78	1.15	62.71790	23/51	1389
45	60	3665	225S/M	135	67.5	8.5	J	86.5	2.9	3.6	91.0	92.4	93.0	0.81	0.88	0.90	1.15	9.36481	16/35	849
		1780	225S/M	136	67.8	7.4	H	178	3.0	3.2	92.4	93.0	93.6	0.77	0.85	0.89	1.15	19.92940	12/26	882
		1190	280S/M	146	73.2	7.2	H	267	2.2	2.6	93.0	93.6	94.1	0.67	0.77	0.82	1.15	54.53720	25/55	1345
		890	280S/M	160	80.0	8.5	L	356	2.3	2.8	93.0	93.6	94.1	0.58	0.69	0.75	1.15	62.71790	26/57	1389
55	75	3565	250S/M	163	81.6	8.9	J	109	2.8	3.6	90.2	92.4	93.0	0.84	0.89	0.91	1.15	13.19600	15/33	1080
		1780	250S/M	167	83.4	7.4	H	218	3.1	3.5	93.0	94.1	94.1	0.75	0.84	0.88	1.15	27.40290	20/44	992
		1190	280S/M	178	89.1	7.0	H	326	2.2	2.6	93.6	94.1	94.5	0.66	0.77	0.82	1.15	62.71790	45/99	1444
		890	315S/M	187	93.7	7.8	J	436	2.0	2.5	93.6	94.1	94.5	0.64	0.74	0.78	1.15	81.80610	27/59	1610
75	100	3575	280S/M	232	116	8.6	J	148	2.3	3.4	90.2	93.0	93.6	0.78	0.84	0.87	1.15	30.15680	51/112	1687
		1785	280S/M	228	114	8.0	J	296	2.3	2.6	93.0	94.1	94.5	0.75	0.83	0.87	1.15	51.44640	21/46	1455
		1190	315S/M	234	117	6.4	G	444	2.1	2.2	94.1	94.5	95.0	0.74	0.82	0.85	1.15	81.80610	24/53	1599
		895	315S/M	266	133	9.5	M	591	2.8	3.0	92.5	93.0	93.0	0.62	0.72	0.76	1.15	114.5283	19/42	2007
90	125	3575	280S/M	272	136	8.8	J	177	2.5	3.5	91.0	93.6	94.5	0.79	0.85	0.88	1.15	33.50770	33/73	1632
		1785	280S/M	274	137	8.6	J	355	2.6	2.8	93.6	94.1	94.5	0.75	0.83	0.87	1.15	66.68980	22/48	1753
		1190	315S/M	280	140	7.0	G	533	2.4	2.4	94.1	94.5	95.0	0.73	0.81	0.85	1.15	95.44040	48/106	1786
		890	315S/M	296	148	7.8	J	713	2.2	2.5	95.0	95.0	95.4	0.68	0.77	0.80	1.15	125.4358	28/62	2117
110	150	3575	315S/M	332	166	8.8	J	217	2.5	3.4	92.4	94.1	94.5	0.80	0.86	0.88	1.15	35.74140	38/84	1830
		1785	280S/M	334	167	8.6	J	434	2.6	2.7	91.1	94.5	95.0	0.78	0.84	0.87	1.15	76.21700	29/64	1852
		1185	315S/M	364	182	7.6	J	654	3.1	3.0	93.0	94.5	95.0	0.62	0.74	0.80	1.15	125.4358	30/66	2161
		895	355M/L	382	191	6.8	H	866	1.4	2.4	92.5	93.6	94.1	0.59	0.71	0.77	1.15	298.0590	41/90	3065
132	175	3575	315S/M	394	197	8.8	J	260	2.5	3.3	93.0	94.1	94.5	0.83	0.88	0.89	1.15	41.32600	32/70	1985
		1785	315S/M	410	205	8.3	J	521	2.6	2.8	94.1	94.5	95.0	0.72	0.81	0.85	1.15	89.55490	34/75	2194
		1190	355M/L	442	221	6.4	H	782	2.0	2.3	93.0	94.1	95.0	0.65	0.74	0.79	1.15	226.1773	60/132	3014
		895	355M/L	458	229	6.7	H	1039	1.4	2.4	92.6	93.6	94.1	0.59	0.71	0.77	1.15	312.9619	41/90	3186
150	200	3575	315S/M	440	220	8.6	J	296	2.5	3.1	93.6	94.5	95.0	0.85	0.89	0.90	1.15	50.26160	37/81	2183
		1785	315S/M	466	233	8.4	J	592	2.8	2.9	94.1	94.5	95.0	0.73	0.81	0.85	1.15	89.55490	18/40	2205
		1195	355M/L	496	248	6.7	H	885	2.3	2.4	93.5	94.5	95.0	0.66	0.76	0.80	1.15	237.4863	58/128	3308
		895	355M/L	514	257	7.0	J	1181	1.5	2.5	93.0	94.1	94.1	0.60	0.72	0.78	1.15	387.4767	41/90	3506
185	250	3575	315S/M	554	277	9.4	K	365	2.9	3.9	93.6	94.5	95.4	0.77	0.85	0.88	1.15	50.26160	37/81	2183
		1785	315S/M	588	294	8.6	K	730	2.7	3.0	93.6	94.5	95.0	0.69	0.78	0.83	1.15	89.55490	19/42	2216
		1195	355M/L	612	306	7.0	H	1091	2.5	2.7	93.5	94.5	95.0	0.65	0.75	0.80	1.15	277.0672	60/132	3528
		895	355M/L	630	315	7.3	J	1457	1.6	2.6	93.0	94.1	94.5	0.60	0.71	0.78	1.15	461.9913	41/90	4145
220	300	3585	355M/L	636	318	9.2	J	432	2.4	3.5	93.8	95.0	95.4	0.83	0.89	0.91	1.15	122.7090	63/139	3638
		1790	355M/L	666	333	8.0	H	866	2.3	2.6	94.3	95.0	95.4	0.79	0.85	0.87	1.15	185.7931	35/77	3572
		1195	355M/L	736	368	7.2	H	1297	2.5	2.6	94.1	95.0	95.0	0.64	0.74	0.79	1.15	327.9572	60/132	3958
		895	355M/L	740	370	7.6	J	1732	1.8	2.5	93.8	94.5	94.5	0.62	0.73	0.79	1.15	484.3459	31/68	4256
260	350	3585	355M/L	744	372	8.6	J	511	2.3	3.2	94.4	95.4	95.4	0.87	0.91	0.92	1.15	136.3433	63/139	3749
		1790	355M/L	786	393	7.9	H	1024	2.4	2.6	94.0	95.0	95.4	0.80	0.85	0.87	1.15	199.0641	10/22	3043
		1195	355M/L	858	429	6.7	H	1533	2.4	2.4	94.2	95.0	95.0	0.66	0.76	0.80	1.15	399.2661	60/132	4013
300	400	1790	355M/L	898	449	7.5	H	1181	2.3	2.4	94.2	95.0	95.4	0.83	0.86	0.88	1.15	243.3006	30/66	3903
		1190	355M/L	966	483	6.0	G	1777	2.0	2.0	94.5	95.0	95.0	0.72	0.80	0.82	1.15	350.5749	50/110	4079
330	450	1190	355M/L	1090	545	6.2	G	1954	2.1	2.1	94.5	95.0	95.0	0.67	0.76	0.80	1.15	367.5383	50/110	4190

The values shown are subject to change without prior notice. To obtain guaranteed values, please contact our nearest sales office.



Tru-Metric™ - TEFC (IP55)

High Efficiency - IEC Metric Frame

Suitable for
Inverter Duty

IEC
60Hz / 50Hz

Electrical Data - 50Hz - 380V

Rated Output		Rated Speed rpm	IEC Frame	Full Load Current In A At 460V	LRC FLC	Locked Rotor Current kVA code	Full Load Torque Tn Lb.Ft	Locked Rotor Torque TI/Tn	Break-Down Torque Tb/Tn	Efficiency η %			Power Factor Cos φ			Service Factor SF	Moment of Inertia Wk ² Lb.Ft ²	Allowable Locked Rotor Time Hot/Cold (s)	Approx. Weight Lb
kW	HP									% of full load									
										50	75	100	50	75	100				
0.18	0.25	2700	63	0.50	4.4	G	0.47	2.2	2.3	62.0	66.0	68.0	0.58	0.70	0.80	1.00	0.00285	20/44	8
		1390	63	0.55	4.6	H	0.91	2.0	2.1	63.0	66.0	68.0	0.50	0.63	0.73	1.00	0.01329	19/42	10
		880	71	0.79	3.5	J	1.44	2.1	2.2	53.0	59.0	61.0	0.37	0.47	0.57	1.00	0.01875	15/33	13
		690	80	0.78	4.5	L	1.84	1.7	1.8	44.0	53.3	55.5	0.45	0.55	0.63	1.00	0.05743	8/18	19
0.25	0.33	2700	63	0.68	4.6	G	0.65	2.5	2.6	65.0	68.0	70.0	0.56	0.70	0.80	1.00	0.00380	22/48	10
		1385	71	0.75	5.0	J	1.27	2.6	2.6	68.0	70.0	72.0	0.47	0.61	0.70	1.00	0.01875	32/70	13
		880	71	1.04	3.5	J	2.00	2.0	2.0	57.0	62.0	63.0	0.37	0.48	0.58	1.00	0.02278	11/24	15
		690	80	0.95	4.1	J	2.55	1.7	1.7	52.0	61.0	63.8	0.43	0.55	0.63	1.00	0.06977	10/22	21
0.37	0.5	2760	71	0.93	5.5	H	0.94	2.3	2.5	70.0	72.0	73.0	0.63	0.75	0.83	1.00	0.00783	23/51	12
		1370	71	1.13	5.0	J	1.90	2.6	2.6	68.0	71.0	73.0	0.45	0.58	0.68	1.00	0.01875	36/79	13
		920	80	1.16	5.2	J	2.83	1.6	2.0	64.0	68.5	70.0	0.48	0.63	0.69	1.00	0.05743	16/35	18
		680	90 S	1.45	4.5	K	3.83	2.2	2.2	55.0	64.9	67.0	0.44	0.52	0.58	1.00	0.10631	12/26	33
0.55	0.75	2750	71	1.31	5.7	H	1.41	2.4	2.4	73.0	74.0	75.0	0.67	0.79	0.85	1.00	0.01068	16/35	15
		1410	80	1.36	5.7	H	2.75	2.2	2.5	71.0	76.0	77.0	0.62	0.74	0.80	1.00	0.05743	10/22	20
		910	80	1.56	5.3	J	4.26	2.0	2.1	65.0	68.5	70.5	0.53	0.67	0.76	1.00	0.07380	9/20	23
		680	90 L	1.82	5.2	K	5.70	2.2	2.1	65.0	73.5	74.0	0.45	0.53	0.62	1.00	0.14618	11/24	37
0.75	1	2750	80	1.68	6.0	H	1.92	2.4	2.4	75.0	78.0	78.0	0.75	0.84	0.87	1.00	0.01875	18/40	20
		1400	80	1.69	5.5	G	3.78	2.2	2.3	76.5	78.5	80.3	0.66	0.78	0.84	1.00	0.06977	8/18	23
		930	90 S	1.99	5.3	H	5.68	2.0	2.0	77.0	78.5	76.4	0.54	0.67	0.75	1.00	0.14618	22/48	53
		690	100 L	2.43	4.6	J	7.66	1.7	2.0	71.5	74.0	75.5	0.44	0.54	0.62	1.00	0.26601	16/35	49
1.1	1.5	2800	80	2.41	7.2	J	2.77	2.9	2.9	79.0	80.0	81.5	0.69	0.79	0.85	1.00	0.02278	10/22	22
		1450	90 S	2.59	7.5	K	5.35	2.3	2.4	81.5	83.8	83.8	0.56	0.70	0.77	1.00	0.11960	10/22	31
		910	90 L	3.33	5.5	K	8.52	2.2	2.2	70.0	72.5	74.8	0.50	0.60	0.67	1.00	0.15947	8/18	40
		690	100 L	3.34	4.2	G	11.2	1.4	2.0	71.0	74.5	76.9	0.43	0.56	0.65	1.00	0.34575	18/40	75
1.5	2	2845	90 S	3.09	7.3	J	3.72	2.3	2.5	83.0	84.3	84.7	0.71	0.83	0.87	1.00	0.04865	10/22	32
		1450	90 L	3.26	8.6	L	7.29	2.6	3.0	83.5	85.5	85.2	0.60	0.74	0.82	1.00	0.15947	9/20	40
		945	100 L	4.22	5.5	J	11.2	2.2	2.5	77.0	79.0	79.5	0.47	0.59	0.68	1.00	0.34575	25/55	66
		700	112 M	4.09	5.7	J	15.1	2.1	2.6	79.8	81.0	82.0	0.47	0.58	0.68	1.00	0.57664	17/37	77
2.2	3	2850	90 L	4.50	8.0	J	5.44	2.5	2.7	85.2	86.3	86.4	0.70	0.81	0.86	1.00	0.05743	6/13	33
		1440	100 L	5.02	9.4	M	10.8	3.9	4.0	85.5	86.5	86.5	0.56	0.69	0.77	1.00	0.29069	10/22	71
		955	112 M	5.58	7.0	K	16.2	2.7	2.7	84.0	85.5	85.5	0.49	0.62	0.70	1.00	0.62101	16/35	99
		700	132 S	5.56	7.0	K	22.1	2.2	2.5	82.5	84.0	84.6	0.51	0.63	0.71	1.00	1.78616	20/44	132
3	4	2880	100 L	5.89	8.2	J	7.34	2.3	2.7	86.5	88.0	88.0	0.76	0.85	0.88	1.00	0.14618	8/18	55
		1430	100 L	6.75	7.6	K	14.8	3.6	3.6	85.7	86.5	85.5	0.59	0.72	0.79	1.00	0.29069	10/22	71
		970	132 S	7.36	7.1	K	21.8	2.2	2.7	84.0	86.0	86.0	0.52	0.64	0.72	1.00	1.37990	20/44	146
		700	132 M	7.14	6.0	H	30.2	2.1	2.2	84.3	86.0	86.3	0.54	0.66	0.74	1.00	2.02441	19/42	154
3.7	5	2885	112 M	7.73	8.2	J	9.77	2.2	2.8	86.7	88.0	88.3	0.77	0.85	0.89	1.00	0.19981	10/22	71
		1445	112 M	8.47	7.1	J	19.5	1.8	2.3	87.5	88.5	87.5	0.66	0.77	0.82	1.00	0.44494	12/26	90
		965	132 M	9.29	6.6	J	29.2	2.2	2.4	84.2	86.8	87.2	0.60	0.70	0.75	1.00	1.37990	20/44	174
		720	160 M	10.0	5.6	H	39.2	2.0	2.6	84.5	86.0	86.5	0.48	0.61	0.70	1.00	2.89720	24/53	243
5.5	7.5	2930	132 S	10.6	8.0	J	13.2	2.2	2.7	89.0	90.3	90.2	0.75	0.83	0.87	1.00	0.57664	15/33	110
		1460	132 S	10.9	8.5	K	26.5	2.1	2.8	88.2	89.5	90.0	0.68	0.80	0.85	1.00	1.28783	9/20	88
		940	132 M	12.4	6.8	J	41.2	2.0	2.3	83.6	86.6	87.6	0.60	0.71	0.77	1.00	1.56381	11/24	154
		720	160 M	13.7	5.6	H	53.8	2.0	2.6	84.2	86.6	87.0	0.46	0.60	0.70	1.00	3.40858	20/44	278
7.5	10	2915	132 S	14.3	8.0	J	18.1	2.1	2.7	88.9	90.5	90.6	0.74	0.83	0.88	1.00	0.57664	8/18	110
		1455	132 M	14.3	8.2	J	36.3	2.0	2.6	88.0	89.8	90.3	0.75	0.84	0.88	1.00	1.56381	8/18	148
		965	160 M	15.5	6.6	H	54.8	2.0	2.6	86.9	89.0	89.9	0.66	0.77	0.82	1.00	3.40858	16/35	276
		720	160 L	17.8	5.2	G	73.4	1.8	2.4	85.5	88.2	89.0	0.50	0.64	0.72	1.00	4.43110	15/33	320
11	15	2945	160 M	21.3	8.5	J	26.3	2.5	3.0	90.3	91.9	92.2	0.76	0.81	0.85	1.00	1.25650	12/26	243
		1450	160 M	21.6	6.0	G	53.5	1.8	2.1	90.9	91.5	91.0	0.72	0.81	0.85	1.00	2.38178	19/42	276
		970	160 L	22.8	7.0	H	79.9	2.0	2.3	89.9	90.5	90.3	0.64	0.76	0.81	1.00	4.17529	12/26	300
		720	180 L	23.8	7.0	J	108	2.0	2.2	86.7	88.5	89.0	0.63	0.75	0.79	1.00	7.19897	10/22	404
15	20	2930	160 M	28.7	8.2	J	36.1	2.2	2.6	90.9	91.7	92.4	0.76	0.83	0.86	1.00	1.25650	11/24	243
		1460	160 L	29.6	6.1	G	72.4	1.8	2.1	90.0	91.9	91.8	0.71	0.80	0.84	1.00	2.73892	11/24	287
		960	180 L	27.6	7.3	H	110	2.4	2.5	91.0	91.8	91.6	0.80	0.88	0.90	1.00	8.18068	12/26	459
		720	200 L	34.9	5.0	G	147	1.8	2.0	89.0	90.8	90.8	0.55	0.67	0.72	1.00	8.93909	33/73	496
18.5	25	2940	160 L	34.7	8.8	K	44.3	2.0	2.5	92.0	92.8	93.0	0.76	0.84	0.87	1.00	1.53557	11/24	287
		1465	180 M	35.9	8.0	J	89	2.7	2.7	91.8	93.0	93.3	0.70	0.80	0.84	1.00	4.68264	12/26	386
		970	200 L	35.6	6.5	G	134	2.2	2.3	90.6	92.6	92.9	0.72	0.80	0.85	1.00	8.93909	25/55	494
		730	225S/M	36.0	7.8	J	179	2.0	2.3	90.3	91.0	91.8	0.73	0.81	0.85	1.00	20.1045	16/35	750

The values shown are subject to change without prior notice. To obtain guaranteed values, please contact our nearest sales office.

IEC Tru-Metric™ - TEFC (IP55)

High Efficiency - IEC Metric Frame

Suitable for
Inverter Duty

IEC
60Hz / 50Hz



Electrical Data - 50Hz - 380V

Rated Output		Rated Speed rpm	IEC Frame	Full Load Current In A At 460V	LRC FLC	Locked Rotor Current kVA code	Full Load Torque Tn Lb.Ft	Locked Rotor Torque Tl/Tn	Break-Down Torque Tb/Tn	Efficiency η %			Power Factor Cos φ			Service Factor SF	Moment of Inertia WK² Lb.Ft²	Allowable Locked Rotor Time Hot/Cold (s)	Approx. Weight Lb
kW	HP									% of full load									
					50	75	100	50	75	100									
22	30	2945	180 M	40.1	8.6	J	52.6	2.5	2.4	92.9	93.7	93.7	0.78	0.86	0.89	1.00	2.82838	9/20	397
		1470	180 L	41.1	8.6	J	105	2.5	2.6	92.2	93.4	93.5	0.75	0.84	0.87	1.00	5.53407	11/24	430
		970	200 L	42.8	7.0	H	160	2.2	2.4	91.0	92.5	92.9	0.70	0.78	0.84	1.00	10.6420	20/44	562
		735	225S/M	43.7	8.5	K	211	2.0	2.6	91.5	92.0	92.2	0.67	0.78	0.83	1.00	23.4552	15/33	805
30	40	2950	200 L	54.0	7.4	H	71.7	2.5	2.1	92.7	93.6	93.8	0.86	0.89	0.90	1.00	4.89550	13/29	540
		1475	200 L	57.1	7.0	H	143	2.2	2.3	93.5	94.1	93.9	0.71	0.81	0.85	1.00	7.85344	18/40	529
		980	225S/M	57.7	8.0	J	216	2.3	2.8	91.5	93.2	93.0	0.70	0.80	0.85	1.00	23.45520	18/40	807
		730	250S/M	58.5	8.5	K	290	2.0	2.8	92.5	93.0	92.8	0.68	0.78	0.84	1.00	29.04010	16/35	970
37	50	2955	200 L	68.6	8.3	J	88.2	2.5	2.5	93.3	94.0	94.2	0.72	0.82	0.87	1.00	5.32122	18/40	573
		1475	225S/M	68.0	7.2	H	177	2.0	2.4	92.9	94.0	94.0	0.79	0.86	0.88	1.00	16.60790	14/31	893
		970	250S/M	71.2	7.0	H	269	2.2	2.2	91.5	94.0	94.0	0.77	0.83	0.84	1.00	31.27380	20/44	992
		740	280S/M	74.9	7.6	J	352	1.6	2.0	92.5	93.5	93.8	0.69	0.77	0.80	1.00	62.71790	23/51	1389
45	60	2955	225S/M	79.5	8.5	J	107	2.2	2.7	93.9	94.5	94.5	0.84	0.89	0.91	1.00	9.36481	16/35	849
		1475	225S/M	80.6	7.4	H	215	2.1	2.5	94.0	94.3	94.2	0.82	0.88	0.90	1.00	19.92940	12/26	882
		980	280S/M	86.5	7.2	H	324	2.2	2.5	92.0	93.3	94.1	0.71	0.80	0.84	1.00	54.53720	25/55	1345
		735	280S/M	92.1	7.0	H	431	1.8	1.8	92.8	93.6	94.0	0.63	0.74	0.79	1.00	62.71790	26/57	1389
55	75	2960	250S/M	95.9	8.9	J	131	2.2	2.9	94.2	94.7	94.7	0.86	0.90	0.92	1.00	13.19600	15/33	1080
		1475	250S/M	98.3	7.4	H	263	2.1	2.5	94.2	94.6	94.5	0.79	0.87	0.90	1.00	27.40290	20/44	992
		980	280S/M	108	7.0	H	396	2.2	2.3	92.5	93.9	94.2	0.68	0.77	0.82	1.00	62.71790	45/99	1444
		735	315S/M	107	6.5	G	527	1.8	1.9	93.8	94.3	94.4	0.71	0.80	0.83	1.00	81.80610	27/59	1610
75	100	2970	280S/M	136	7.7	H	178	1.6	2.7	93.0	94.4	95.0	0.83	0.87	0.88	1.00	30.15680	51/112	1687
		1480	280S/M	136	7.2	H	357	2.0	2.2	93.5	94.8	95.0	0.81	0.87	0.88	1.00	51.44640	21/46	1455
		980	315S/M	142	6.8	H	539	2.0	2.2	93.0	94.0	94.5	0.77	0.83	0.85	1.00	81.80610	24/53	1599
		740	315S/M	148	9.0	K	714	2.2	2.3	93.0	94.0	94.8	0.66	0.77	0.81	1.00	114.5283	19/42	2007
90	125	2970	280S/M	159	8.2	H	214	1.6	2.4	94.3	95.5	95.8	0.84	0.88	0.90	1.00	33.50770	33/73	1632
		1485	280S/M	161	7.8	H	427	2.2	2.3	94.4	95.1	95.2	0.81	0.87	0.89	1.00	66.68980	22/48	1753
		980	315S/M	172	6.5	G	647	2.0	2.0	92.9	94.3	94.8	0.74	0.81	0.84	1.00	95.44040	48/106	1786
		735	315S/M	167	6.8	G	863	2.0	2.0	94.0	94.8	95.0	0.73	0.80	0.86	1.00	125.4358	28/62	2117
110	150	2970	315S/M	194	8.0	H	261	1.6	2.4	94.4	95.5	95.8	0.84	0.88	0.90	1.00	35.74140	38/84	1830
		1480	280S/M	197	7.6	H	524	2.2	2.3	94.6	95.1	95.4	0.82	0.87	0.89	1.00	76.21700	29/64	1852
		980	315S/M	207	6.8	G	791	2.1	2.2	93.6	94.8	95.1	0.73	0.73	0.85	1.00	125.4358	30/66	2161
		745	355M/L	220	6.6	H	1041	1.2	2.0	94.5	94.9	95.0	0.65	0.75	0.80	1.00	298.0590	41/90	3065
132	175	2970	315S/M	235	8.3	J	313	1.7	2.3	94.3	95.5	96.0	0.80	0.87	0.89	1.00	41.32600	32/70	1985
		1480	315S/M	236	7.8	H	629	2.2	2.3	94.9	95.3	95.6	0.83	0.88	0.89	1.00	89.55490	34/75	2194
		990	355M/L	262	5.8	G	940	1.6	1.9	93.5	94.5	94.6	0.71	0.79	0.81	1.00	226.1773	60/132	3014
		745	355M/L	264	6.5	H	1249	1.2	2.0	94.5	95.0	95.1	0.66	0.75	0.80	1.00	312.9619	41/90	3186
150	200	2970	315S/M	264	7.5	H	356	1.8	2.3	95.0	95.8	96.1	0.86	0.89	0.90	1.00	50.26160	37/81	2183
		1480	315S/M	270	8.0	J	714	2.2	2.5	94.2	95.5	95.9	0.80	0.86	0.88	1.00	89.55490	18/40	2205
		990	355M/L	290	6.5	G	1068	1.8	2.0	94.2	95.5	95.7	0.70	0.79	0.82	1.00	237.4863	58/128	3308
		745	355M/L	298	6.8	H	1419	1.3	2.0	94.5	95.2	95.5	0.67	0.76	0.80	1.00	387.4767	41/90	3506
185	250	2970	315S/M	325	7.2	G	439	1.8	2.3	95.0	95.9	96.2	0.86	0.89	0.90	1.00	50.26160	37/81	2183
		1485	315S/M	341	7.3	H	878	2.3	2.7	94.9	95.7	95.8	0.73	0.82	0.86	1.00	89.55490	19/42	2216
		990	355M/L	358	6.7	H	1317	2.0	2.1	94.2	95.5	95.7	0.71	0.78	0.82	1.00	277.0672	60/132	3528
		745	355M/L	368	7.0	H	1750	1.4	2.0	94.8	95.2	95.6	0.67	0.76	0.80	1.00	461.9913	41/90	4145
220	300	2985	355M/L	377	8.5	H	519	2.0	2.8	95.0	96.0	96.4	0.86	0.90	0.92	1.00	122.7090	63/139	3638
		1490	355M/L	390	8.0	H	1041	2.1	2.3	95.2	96.0	96.3	0.83	0.88	0.89	1.00	185.7931	35/77	3572
		990	355M/L	431	6.9	H	1566	2.0	2.1	94.5	95.5	95.7	0.70	0.78	0.81	1.00	327.9572	60/132	3958
		740	355M/L	432	7.4	H	2095	1.5	2.0	95.0	95.5	95.6	0.68	0.78	0.81	1.00	484.3459	31/68	4256
260	350	2980	355M/L	446	8.2	H	615	1.9	2.5	95.4	96.1	96.2	0.89	0.91	0.92	1.00	136.3433	63/139	3749
		1490	355M/L	472	6.3	F	1230	1.9	2.2	94.0	94.8	95.2	0.83	0.86	0.88	1.00	199.0641	10/22	3043
		990	355M/L	503	6.5	G	1851	1.9	2.0	94.8	95.5	95.7	0.72	0.80	0.82	1.00	339.2661	60/132	4013
300	400	1485	355M/L	544	6.0	F	1424	1.9	2.0	94.2	94.8	95.2	0.84	0.86	0.88	1.00	243.3006	30/66	3903
		990	355M/L	580	5.7	F	2136	1.7	1.7	95.0	95.5	95.8	0.77	0.81	0.82	1.00	350.5749	50/110	4079
330	450	990	355M/L	645	5.8	F	2349	1.7	1.7	95.1	95.7	96.0	0.73	0.80	0.81	1.00	367.5383	50/110	4190

The values shown are subject to change without prior notice. To obtain guaranteed values, please contact our nearest sales office.



Tru-Metric™ - TEFC (IP55)

High Efficiency - IEC Metric Frame

Suitable for
Inverter Duty

IEC
60Hz / 50Hz

Electrical Data - 50Hz - 415V

Rated Output		Rated Speed rpm	IEC Frame	Full Load Current In A At 460V	LRC FLC	Locked Rotor Current kVA code	Full Load Torque Tn Lb.Ft	Locked Rotor Torque TI/Tn	Break-Down Torque Tb/Tn	Efficiency η %			Power Factor Cos φ			Service Factor SF	Moment of Inertia Wk ² Lb.Ft ²	Allowable Locked Rotor Time Hot/Cold (s)	Approx. Weight Lb
kW	HP									% of full load									
										50	75	100	50	75	100				
0.18	0.25	2760	63	0.53	4.4	H	0.46	2.8	2.8	58.0	64.0	67.0	0.48	0.60	0.70	1.00	0.00285	20/44	8
		1410	63	0.57	4.6	J	0.90	2.6	2.7	60.0	66.0	68.0	0.42	0.54	0.65	1.00	0.01329	19/42	10
		900	71	0.88	3.5	K	1.41	2.6	2.6	47.0	54.0	58.0	0.32	0.41	0.49	1.00	0.01875	15/33	13
		710	80	0.78	4.5	M	1.79	1.9	2.0	43.9	53.0	56.3	0.40	0.50	0.57	1.00	0.05743	8/18	19
0.25	0.33	2760	63	0.68	4.6	H	0.64	2.8	3.0	63.0	67.0	71.0	0.47	0.61	0.72	1.00	0.00380	22/48	10
		1410	71	0.76	5.0	K	1.25	3.1	3.1	67.0	71.0	72.0	0.41	0.54	0.64	1.00	0.01875	32/70	13
		900	71	1.12	3.5	K	1.96	2.6	2.6	51.0	58.0	61.0	0.33	0.42	0.51	1.00	0.02278	11/24	15
		710	80	0.92	4.1	K	2.48	1.9	1.9	56.5	62.5	64.2	0.40	0.52	0.59	1.00	0.06977	10/22	21
0.37	0.5	2800	71	0.92	5.5	J	0.93	2.8	3.0	69.0	72.0	73.0	0.54	0.67	0.77	1.00	0.00783	23/51	12
		1410	71	1.21	5.0	K	1.85	3.2	3.2	64.0	70.0	71.0	0.38	0.50	0.60	1.00	0.01875	36/79	13
		930	80	1.19	5.2	K	2.80	1.8	2.2	61.0	67.0	70.0	0.40	0.58	0.62	1.00	0.05743	16/35	18
		690	90 S	1.42	4.5	L	3.78	2.4	2.5	52.0	64.0	67.0	0.35	0.47	0.54	1.00	0.10631	12/26	33
0.55	0.75	2820	71	1.26	5.7	H	1.37	2.9	2.9	72.0	74.0	76.0	0.58	0.71	0.80	1.00	0.01068	16/35	15
		1455	80	1.30	5.7	J	2.66	2.8	2.9	72.0	76.5	78.3	0.53	0.67	0.75	1.00	0.05743	10/22	20
		930	80	1.63	5.3	K	4.17	2.2	2.3	60.0	68.9	71.0	0.44	0.60	0.66	1.00	0.07380	9/20	23
		700	90 L	1.79	5.2	K	5.54	2.4	2.4	65.0	73.0	73.5	0.37	0.50	0.58	1.00	0.14618	11/24	37
0.75	1	2800	80	1.57	6.0	H	1.89	2.8	2.9	77.0	79.0	79.0	0.67	0.79	0.84	1.00	0.01875	18/40	20
		1430	80	1.61	5.5	H	3.70	2.6	2.8	78.5	80.0	81.1	0.58	0.72	0.80	1.00	0.06977	8/18	23
		940	90 S	1.92	5.3	J	5.62	2.6	2.4	77.1	78.9	77.8	0.48	0.61	0.70	1.00	0.14618	22/48	53
		710	100 L	2.29	4.6	J	7.44	1.9	2.2	70.0	74.0	76.0	0.38	0.51	0.60	1.00	0.26601	16/35	49
1.1	1.5	2825	80	2.35	7.2	K	2.74	3.4	3.4	78.0	80.0	81.5	0.58	0.71	0.80	1.00	0.02278	10/22	22
		1460	90 S	2.66	7.5	L	5.31	2.7	3.0	75.0	83.0	83.5	0.47	0.62	0.69	1.00	0.11960	10/22	31
		930	90 L	3.30	5.5	K	8.34	2.4	2.4	69.5	72.5	74.9	0.45	0.55	0.62	1.00	0.15947	8/18	40
		710	100 L	3.26	4.2	H	10.9	1.6	2.2	70.0	74.0	77.0	0.39	0.51	0.61	1.00	0.34575	18/40	75
1.5	2	2865	90 S	2.95	7.3	J	3.69	2.8	3.1	83.0	84.9	85.3	0.63	0.76	0.83	1.00	0.04865	10/22	32
		1460	90 L	3.32	8.6	M	7.24	3.0	3.6	83.0	84.6	85.0	0.50	0.64	0.74	1.00	0.15947	9/20	40
		955	100 L	4.24	5.5	K	11.1	2.8	3.2	74.0	78.5	79.3	0.40	0.52	0.62	1.00	0.34575	25/55	66
		715	112 M	4.05	5.7	K	14.8	2.4	3.0	79.3	80.8	81.8	0.43	0.55	0.63	1.00	0.57664	17/37	77
2.2	3	2860	90 L	4.31	8.0	K	5.42	3.1	3.3	84.8	86.0	86.6	0.58	0.73	0.82	1.00	0.05743	6/13	33
		1445	100 L	4.98	9.4	N	10.7	4.9	5.0	83.8	86.0	86.5	0.48	0.62	0.71	1.00	0.29069	10/22	71
		965	112 M	5.51	7.0	L	16.1	3.5	3.5	82.5	85.5	85.5	0.42	0.55	0.65	1.00	0.62101	16/35	99
		715	132 S	5.26	7.0	K	21.7	2.6	2.9	81.6	83.9	84.4	0.48	0.59	0.69	1.00	1.78616	20/44	132
3	4	2900	100 L	5.50	8.2	K	7.29	2.9	3.3	86.3	88.0	88.3	0.65	0.80	0.86	1.00	0.14618	8/18	55
		1440	100 L	6.69	8.6	M	14.7	4.5	4.6	83.9	85.5	85.5	0.50	0.64	0.73	1.00	0.29069	10/22	71
		975	132 S	7.16	8.4	M	21.7	2.8	3.1	83.0	86.0	87.0	0.45	0.58	0.67	1.00	1.37990	20/44	146
		715	132 M	6.72	6.0	J	29.6	2.5	2.6	84.0	85.5	86.2	0.50	0.63	0.72	1.00	2.02441	19/42	154
3.7	5	2910	112 M	7.31	8.2	J	9.69	2.6	3.4	86.7	88.3	88.5	0.65	0.82	0.86	1.00	0.19981	10/22	71
		1455	112 M	8.06	7.1	J	19.4	2.4	2.9	87.5	88.5	88.5	0.58	0.71	0.78	1.00	0.44494	12/26	90
		970	132 M	9.13	6.6	J	29.1	2.4	2.6	83.5	86.4	87.1	0.50	0.63	0.70	1.00	1.37990	20/44	174
		730	160 M	10.2	5.6	J	38.6	2.4	3.1	84.4	86.0	86.6	0.41	0.54	0.63	1.00	2.89720	24/53	243
5.5	7.5	2950	132 S	10.1	8.0	J	13.1	2.7	3.3	88.0	89.8	90.0	0.70	0.78	0.84	1.00	0.57664	15/33	110
		1470	132 S	10.5	8.5	K	26.4	2.5	3.4	87.5	89.4	89.9	0.55	0.72	0.81	1.00	1.28783	9/20	88
		950	132 M	11.6	6.8	J	40.8	2.2	2.5	83.0	86.5	87.6	0.55	0.68	0.75	1.00	1.56381	11/24	154
		730	160 M	14.7	5.6	J	53.1	2.5	3.0	84.1	86.4	87.0	0.38	0.50	0.60	1.00	3.40858	20/44	278
7.5	10	2920	132 S	13.3	8.0	J	18.1	2.6	3.2	88.5	90.7	90.9	0.70	0.80	0.86	1.00	0.57664	8/18	110
		1465	132 M	13.8	8.2	K	36.1	2.4	3.1	88.0	89.9	90.3	0.62	0.78	0.84	1.00	1.56381	8/18	148
		970	160 M	14.5	6.6	H	54.5	2.5	3.1	87.0	89.5	90.0	0.58	0.71	0.80	1.00	3.40858	16/35	276
		730	160 L	18.3	5.2	H	72.4	2.2	2.8	85.4	88.1	89.0	0.41	0.54	0.64	1.00	4.43110	15/33	320
11	15	2955	160 M	20.0	8.5	K	26.2	3.0	3.6	90.2	92.0	92.2	0.70	0.79	0.83	1.00	1.25650	12/26	243
		1470	160 M	20.7	6.0	G	52.7	2.2	2.6	90.0	91.6	91.3	0.65	0.75	0.81	1.00	2.38178	19/42	276
		975	160 L	22.3	7.0	J	79.5	2.4	2.7	89.3	90.0	90.3	0.54	0.68	0.76	1.00	4.17529	12/26	300
		730	180 L	22.3	7.0	J	106	2.4	2.6	86.3	88.5	89.0	0.60	0.70	0.77	1.00	7.19897	10/22	404
15	20	2935	160 M	26.9	8.2	J	36	2.7	3.2	90.7	91.6	92.4	0.71	0.81	0.84	1.00	1.25650	11/24	243
		1470	160 L	27.7	6.1	G	71.9	2.2	2.7	90.0	91.9	91.8	0.60	0.74	0.82	1.00	2.73892	11/24	287
		970	180 L	25.9	7.3	H	109	2.6	2.7	91.0	91.8	91.6	0.77	0.85	0.88	1.00	8.18068	12/26	459
		730	200 L	33.1	5.0	G	145	2.1	2.4	89.0	90.8	91.3	0.51	0.63	0.69	1.00	8.93909	33/73	496
18.5	25	2950	160 L	33.3	8.8	K	44.2	2.6	3.0	91.6	92.7	93.0	0.70	0.81	0.83	1.00	1.53557	11/24	287
		1475	180 M	34.5	8.0	J	88.4	3.1	3.1	91.3	92.9	93.3	0.60	0.73	0.80	1.00	4.68264	12/26	386
		980	200 L	33.7	6.5	G	133	2.4	2.7	90.5	92.8	93.0	0.65	0.75	0.82	1.00	8.93909	25/55	494
		740	225S/M	33.8	7.8	J	176	2.2	2.7	90.0	91.0	91.8	0.67	0.77	0.83	1.00	20.10450	16/35	750

The values shown are subject to change without prior notice. To obtain guaranteed values, please contact our nearest sales office.

IEC Tru-Metric™ - TEFC (IP55)

High Efficiency - IEC Metric Frame

Suitable for
Inverter Duty

IEC
60Hz / 50Hz



Electrical Data - 50Hz - 415V

Rated Output		Rated Speed rpm	IEC Frame	Full Load Current In A At 460V	LRC FLC	Locked Rotor Current kVA code	Full Load Torque Tn Lb.Ft	Locked Rotor Torque Tl/Tn	Break-Down Torque Tb/Tn	Efficiency η %			Power Factor Cos φ			Service Factor SF	Moment of Inertia WK² Lb.Ft²	Allowable Locked Rotor Time Hot/Cold (s)	Approx. Weight Lb
kW	HP									% of full load									
					50	75	100	50	75	100									
22	30	2955	180 M	38.6	8.6	J	52.5	3.0	3.0	92.0	93.2	93.4	0.74	0.82	0.85	1.00	2.82838	9/20	397
		1475	180 L	38.5	8.6	J	105	3.0	3.2	92.0	93.4	93.6	0.67	0.78	0.85	1.00	5.53407	11/24	430
		980	200 L	41.2	7.0	H	158	2.5	2.8	91.0	92.5	92.9	0.60	0.72	0.80	1.00	10.64200	20/44	562
		735	225S/M	41.4	8.5	K	211	2.4	3.1	90.8	92.0	92.4	0.60	0.73	0.80	1.00	23.45520	15/33	805
30	40	2960	200 L	50.4	7.4	H	71.4	2.9	2.7	92.8	93.7	94.1	0.82	0.87	0.88	1.00	4.89550	13/29	540
		1480	200 L	54.9	7.0	H	143	2.6	2.9	92.5	93.9	93.8	0.63	0.75	0.81	1.00	7.85344	18/40	529
		985	225S/M	56.1	8.0	K	215	2.8	3.4	91.0	93.2	93.0	0.61	0.74	0.80	1.00	23.45520	18/40	807
		735	250S/M	55.5	8.5	K	288	2.4	3.2	91.5	93.0	92.8	0.62	0.75	0.81	1.00	29.04010	16/35	970
37	50	2965	200 L	63.5	8.3	J	87.9	2.9	2.9	93.0	94.0	94.3	0.70	0.80	0.86	1.00	5.32122	18/40	573
		1480	225S/M	63.7	7.2	H	176	2.4	2.9	92.5	93.9	93.9	0.70	0.82	0.86	1.00	16.60790	14/31	893
		985	250S/M	68.5	7.0	H	265	2.5	2.6	91.6	93.9	93.9	0.72	0.79	0.80	1.00	31.27380	20/44	992
		745	280S/M	71.3	7.6	J	350	2.0	2.4	91.7	93.0	93.8	0.60	0.72	0.77	1.00	62.71790	23/51	1389
45	60	2965	225S/M	74.4	8.5	J	107	2.7	3.2	93.3	94.4	94.6	0.80	0.87	0.89	1.00	9.36481	16/35	849
		1480	225S/M	75.4	7.4	H	214	2.5	3.1	93.8	94.2	94.4	0.77	0.85	0.88	1.00	19.92940	12/26	882
		985	280S/M	81.2	7.2	H	322	2.6	2.9	91.0	93.2	94.0	0.65	0.76	0.82	1.00	54.53720	25/55	1345
		740	280S/M	91.1	7.0	J	429	2.0	2.2	92.5	93.7	94.1	0.53	0.65	0.73	1.00	62.71790	26/57	1389
55	75	2970	250S/M	89.5	8.9	J	131	2.7	3.6	94.1	95.0	95.0	0.83	0.88	0.90	1.00	13.19600	15/33	1080
		1480	250S/M	91.8	7.4	H	262	2.5	3.1	94.0	94.7	94.7	0.74	0.84	0.88	1.00	27.40290	20/44	992
		985	280S/M	102	7.0	H	394	2.5	2.7	92.0	93.5	94.2	0.60	0.74	0.80	1.00	62.71790	45/99	1444
		740	315S/M	100	6.5	G	524	2.1	2.1	93.5	94.5	94.6	0.65	0.75	0.81	1.00	81.80610	27/59	1610
75	100	2975	280S/M	126	7.7	H	178	2.0	3.0	93.0	94.4	95.0	0.78	0.85	0.87	1.00	30.15680	51/112	1687
		1485	280S/M	126	7.2	H	356	2.4	2.6	93.8	95.0	95.2	0.77	0.84	0.87	1.00	51.44640	21/46	1455
		985	315S/M	133	6.8	H	537	2.3	2.6	92.5	94.0	94.4	0.72	0.79	0.83	1.00	81.80610	24/53	1599
		745	315S/M	145	9.0	L	710	2.8	3.0	92.0	93.5	94.9	0.60	0.70	0.76	1.00	114.5283	19/42	2007
90	125	2975	280S/M	149	8.2	H	213	2.0	3.0	94.3	95.5	95.8	0.81	0.86	0.88	1.00	33.50770	33/73	1632
		1485	280S/M	151	7.8	H	427	2.6	2.9	94.1	95.0	95.3	0.77	0.84	0.87	1.00	66.68980	22/48	1753
		985	315S/M	161	6.5	G	644	2.3	2.3	92.5	94.1	94.8	0.69	0.78	0.82	1.00	95.44040	48/106	1786
		740	315S/M	161	6.8	G	857	2.2	2.4	93.6	94.6	95.1	0.68	0.76	0.82	1.00	125.4358	28/62	2117
110	150	2975	315S/M	182	8.0	H	261	2.0	2.9	94.4	95.4	95.8	0.80	0.86	0.88	1.00	35.74140	38/84	1830
		1485	280S/M	182	7.6	H	522	2.6	2.9	94.0	95.1	95.6	0.78	0.85	0.88	1.00	76.21700	29/64	1852
		985	315S/M	194	6.8	H	787	2.5	2.6	93.3	94.8	95.2	0.66	0.77	0.83	1.00	125.4358	30/66	2161
		745	355M/L	215	6.6	H	1041	1.5	2.4	93.5	94.8	95.0	0.56	0.69	0.75	1.00	298.0590	41/90	3065
132	175	2975	315S/M	217	8.3	J	313	2.1	2.9	94.3	95.5	96.0	0.78	0.85	0.88	1.00	41.32600	32/70	1985
		1485	315S/M	218	7.8	H	626	2.6	2.9	94.7	95.3	95.7	0.78	0.86	0.88	1.00	89.55490	34/75	2194
		990	355M/L	251	5.8	G	940	2.0	2.2	92.7	94.5	94.9	0.63	0.73	0.77	1.00	226.1773	60/132	3014
		745	355M/L	257	6.5	H	1249	1.5	2.4	93.5	94.8	95.1	0.56	0.68	0.75	1.00	312.9619	41/90	3186
150	200	2975	315S/M	244	7.5	H	355	2.1	2.9	95.0	95.8	96.2	0.82	0.88	0.89	1.00	50.26160	37/81	2183
		1485	315S/M	253	8.0	J	712	2.6	2.9	94.2	95.8	95.9	0.75	0.82	0.86	1.00	89.55490	18/40	2205
		995	355M/L	276	6.5	H	1062	2.2	2.4	94.0	95.3	95.7	0.64	0.74	0.79	1.00	237.4863	58/128	3308
		745	355M/L	288	6.8	H	1419	1.6	2.5	94.0	95.0	95.4	0.58	0.70	0.76	1.00	387.4767	41/90	3506
185	250	2975	315S/M	301	7.2	G	438	2.2	2.8	95.0	96.0	96.2	0.82	0.89	0.89	1.00	50.26160	37/81	2183
		1485	315S/M	319	7.3	H	878	2.7	3.2	95.0	95.8	95.9	0.70	0.80	0.84	1.00	89.55490	19/42	2216
		995	355M/L	345	6.7	H	1310	2.4	2.5	94.0	95.3	95.7	0.61	0.72	0.78	1.00	277.0672	60/132	3528
		745	355M/L	355	7.0	J	1750	1.8	2.6	94.1	95.0	95.5	0.58	0.70	0.76	1.00	461.9913	41/90	4145
220	300	2990	355M/L	353	8.5	J	519	2.3	3.4	94.5	96.1	96.4	0.82	0.88	0.90	1.00	122.7090	63/139	3638
		1490	355M/L	366	8.0	H	1041	2.5	2.9	95.0	96.0	96.2	0.77	0.84	0.87	1.00	185.7931	35/77	3572
		995	355M/L	415	6.9	H	1558	2.4	2.5	94.1	95.4	95.7	0.60	0.71	0.77	1.00	327.9572	60/132	3958
		745	355M/L	410	7.4	J	2081	1.9	2.5	94.5	95.4	95.6	0.61	0.72	0.78	1.00	484.3459	31/68	4256
260	350	2985	355M/L	413	8.2	H	614	2.2	3.1	95.1	96.1	96.2	0.87	0.90	0.91	1.00	136.3433	63/139	3749
		1490	355M/L	441	7.5	H	1230	2.2	2.6	94.0	95.0	95.4	0.80	0.84	0.86	1.00	199.0641	10/22	3043
		995	355M/L	485	6.5	J	1842	2.3	2.4	94.2	95.4	95.7	0.62	0.73	0.78	1.00	339.2661	60/132	4013
300	400	1490	355M/L	497	7.1	H	1419	2.3	2.4	94.3	95.0	95.4	0.83	0.86	0.88	1.00	243.3006	30/66	3903
		990	355M/L	545	5.7	F	2136	2.0	2.0	94.4	95.4	95.8	0.70	0.78	0.80	1.00	350.5749	50/110	4079
330	450	990	355M/L	621	5.8	G	2349	2.0	2.1	94.4	95.4	96.0	0.62	0.73	0.77	1.00	367.5383	50/110	4190

The values shown are subject to change without prior notice. To obtain guaranteed values, please contact our nearest sales office.



Mechanical Data - Cast Iron frames

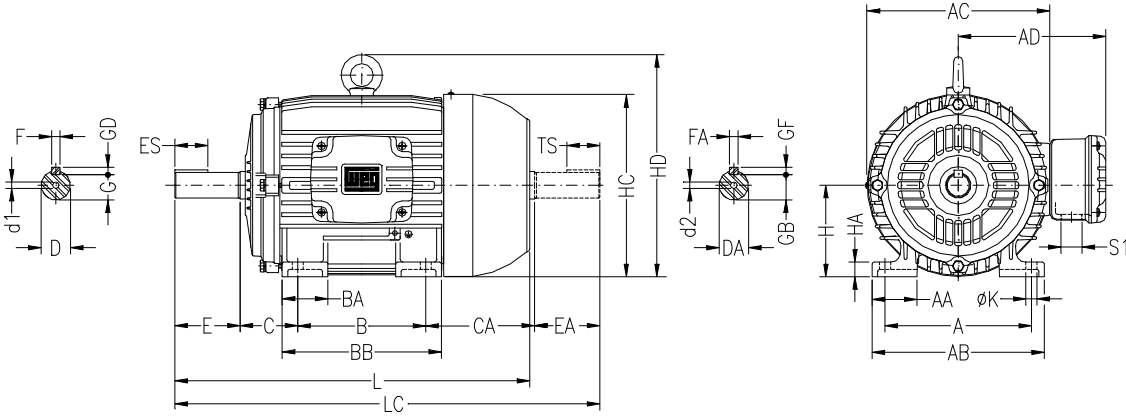

Dimensions in millimeters and inches

FRAME	IEC	NEMA	A	AA	AB	AC	AD	B	BA	BB	C	CA	D.E. Shaft					O.D.E. Shaft				
													D	E	F	G	GD	DA	EA	TS	FA	GB
63	-	100	21	116	125	113	80	22	95	40	78	11j6	23	4	8.5	4	9j6	20	12	3	7.2	3
		3.937	0.827	4.557	4.921	4.449	3.150	0.866	3.740	1.575	3.071	0.430	0.906	14	0.157	0.335	0.157	0.350	0.787	0.472	0.118	0.283
71	-	112	30	132	141	121	90	38	113.5	45	88	14j6	30	5	11	5	11j6	23	4	8.5	4	
		4.409	1.181	5.197	5.551	4.764	3.543	1.496	4.469	1.772	3.465	0.550	1.181	0.197	0.433	0.197	0.430	0.906	14	0.157	0.335	0.157
80	-	125	35	149	159	130	100	40	125.5	50	93	19j6	40	6	15.5	6	14j6	30	5.51	11	11	
		4.921	1.378	5.866	6.260	5.118	3.937	1.575	4.941	1.969	3.661	0.740	1.575	0.866	0.236	0.610	0.236	0.550	1.181	0.433	0.433	0.433
90S	143T	140	38	164	179	150	100	42	131	56	104	24j6	50	28	40	25	16j6	40	25	5	19.7	5
90L	145T	140	38	164	179	150	100	42	131	56	104	24j6	50	28	40	25	16j6	40	25	5	19.7	5
100L	-	160	49	188	199	160	140	50	173	63	118	28j6	60	36	24	28	22j6	50	28	6	23.6	6
112M	184T	190	48	220	222	180	140	50	173	63	118	28j6	60	36	24	28	22j6	50	28	6	23.6	6
132S	213T	216	51	248	270	207	178	55	216	89	150	38j6	80	56	10	33	28j6	60	36	8	31.5	7
132M	215T	216	51	248	270	207	178	55	216	89	150	38j6	80	56	10	33	28j6	60	36	8	31.5	7
160M	254T	254	64	308	312	250	210	65	254	108	174	42j6	120	12	37	42j6	120	12	12	37	8	
160L	256T	254	64	308	312	250	210	65	254	108	174	42j6	120	12	37	42j6	120	12	12	37	8	
180M	284T	279	80	350	358	270	241	75	294	121	200	48j6	80	14	42.5	9	48j6	110	80	14	42.5	9
180L	286T	279	80	350	358	270	241	75	294	121	200	48j6	80	14	42.5	9	48j6	110	80	14	42.5	9
200M	324T	318	82	385	396	294	267	85	332	133	222	55m6	110	16	49	10	55m6	100	16	16	19.29	10
200L	326T	318	82	385	396	294	267	85	332	133	222	55m6	110	16	49	10	55m6	100	16	16	19.29	10
225S/M	364/5TS	356	80	436	476	368	311	105	391	149	280	55m6*	100	6.30	1.929	10	55m6	100	16	16	19.29	10
		14.016	3.150	17.165	18.740	14.488	12.244	4.134	15.394	5.866	280	11.024	255	2.160	3.937	0.394	2.160	3.937	0.630	1.929	0.394	
250S/M	404/5TS	406	506	506	476	368	311	138	449	168	280	60m6	140	18	2.087	11	60m6	140	125	18	53	11
		15.984	19.921	19.921	18.740	14.488	12.244	5.433	17.677	6.614	280	11.024	255	3.360	0.709	2.087	0.433	2.360	5.512	4.921	0.709	2.087
280S/M	444/5TS	457	557	557	476	368	311	142	510	190	280	65m6*	125	20	2.657	12	60m6	140	125	18	53	11
		17.992	21.929	21.929	18.740	14.488	12.244	5.591	20.079	7.480	280	11.024	255	2.560	0.787	2.657	0.472	2.360	5.512	4.921	0.709	2.087
315S/M	504/5TS	508	628	628	476	368	311	152	558	216	280	65m6*	160	18	2.283	11	60m6	140	125	18	53	11
		20.000	24.724	24.724	18.740	14.488	12.244	5.984	21.969	8.504	280	11.024	255	2.560	0.866	2.283	0.433	2.360	5.512	4.921	0.866	2.283
355M/L	586/7TS	610	750	750	476	368	311	200	760	254	280	75m6**	170	18	2.660	12*	60m6	140	125	18	53	11
		24.016	29.528	29.528	18.740	14.488	12.244	7.874	29.921	10.000	280	11.024	255	2.950	1.102	2.660	0.470	2.360	5.512	4.921	0.866	2.283
355M/L	586/7T	610	750	750	476	368	311	200	760	254	280	75m6**	170	18	2.660	12*	60m6	140	125	18	53	11
		24.016	29.528	29.528	18.740	14.488	12.244	7.874	29.921	10.000	280	11.024	255	2.950	1.102	2.660	0.470	2.360	5.512	4.921	0.866	2.283

Continue in
the next
page



Mechanical Data - Cast Iron frames

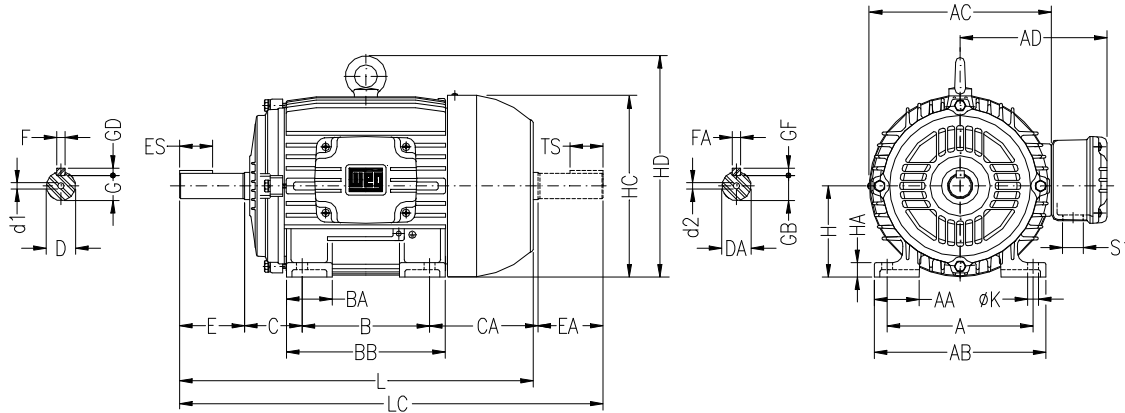

Dimensions in millimeters and inches

FRAME		H	HA	HC	HD	K	L	LC	S1	d1	d2	BEARINGS	
IEC	NEMA											D.E.	O.D.E.
63	-	63 2.480	8 0.315	124 4.882	X	7 0.276	216 8.504	241 9.488	NPT 1/2"	EM4	EM3	6201-ZZ	
71	-	71 2.795	12 0.472	139 5.472		248 9.764	276 10.866	NPT 3/4"	DM6			DM4	6203-ZZ
80	-	80 3.150	13 0.512	157 6.181	276 10.866	313 12.323	NPT 1"			DM10	DM8		6204-ZZ
90S	143T	90 3.543	15 0.591	177 6.969	304 11.969	350 13.780		NPT 1 1/2"	DM16			DM6	6205-ZZ
90L	145T	90 3.543	15 0.591	177 6.969	329 12.953	375 14.764	NPT 1 1/2"			DM16	DM8		6206-ZZ
100L	-	100 3.937	16 0.630	198 7.795	280 11.024	376 14.803		431 16.969	NPT 1"			DM12	DM10
112M	184T	112 4.409	18.5 0.728	235 9.252	280 11.024	393 15.472	448 17.638	NPT 1 1/2"		DM16	DM8		
132S	213T	132 5.197	20 0.787	274 10.787	319 12.559	452 17.795	519 20.433		NPT 2"			DM16	DM10
132M	215T	132 5.197	20 0.787	274 10.787	319 12.559	490 19.291	557 21.929	NPT 1 1/2"		DM16	DM16		
160M	254T	160 6.299	22 0.866	317 12.480	370 14.567	598 23.543	712 28.031		NPT 1 1/2"			DM16	DM16
160L	256T	160 6.299	22 0.866	317 12.480	370 14.567	642 25.276	756 29.764	NPT 2"		DM16	DM16		
180M	284T	180 7.087	28 1.102	360 14.173	413 16.260	664 26.142	782 30.787		NPT 3"			DM16	DM16
180L	286T	180 7.087	28 1.102	360 14.173	413 16.260	702 27.638	820 32.283	NPT 3"		DM16	DM16		
200M	324T	200 7.874	30 1.181	402 15.827	464 18.268	729 28.701	842 33.150		NPT 3"			DM16	DM16
200L	326T	200 7.874	30 1.181	402 15.827	464 18.268	767 30.197	880 34.646	NPT 3"		DM16	DM16		
225S/M	364/5TS	225 8.858	34 1.339	466 18.346	537 21.142	817 32.165	935 36.811		NPT 3"			DM16	DM16
	364/5T							847 33.346		995 39.173	6314-C3		
250S/M	404/5TS	250 9.843	42 1.654	491 19.331	562 22.126	923 36.339	1071 42.165	NPT 3"	DM16	DM16	M20	6314-C3	
	404/5T											1036 40.787	1188 46.772
280S/M	444/5TS	280 11.024	52 2.047	613 24.134	703 27.677	1126 44.331	1278 50.315	NPT 3"	DM16	DM16	M20	6314-C3	
	444/5T											1156 45.512	1308 51.496
315S/M	504/5TS	315 12.402	52 2.047	613 24.134	703 27.677	1126 44.331	1278 50.315	2 x NPT 3"	DM16	DM16	M20	6314-C3	
	504/5T											1156 45.512	1308 51.496
355M/L	586/7TS	355 13.976	50 1.969	725 28.543	834 32.835	1366 53.780	1561 61.457	NPT 3"	DM16	DM16	M20	6316-C3*	
	586/7T											1436 56.535	1661 65.394
										M24	M20	NU-322-C3	6319-C3

Note: * II pole - 60Hz
** II pole - 50Hz

Mechanical Data - Cast Iron frames

'C' and 'C' DIN

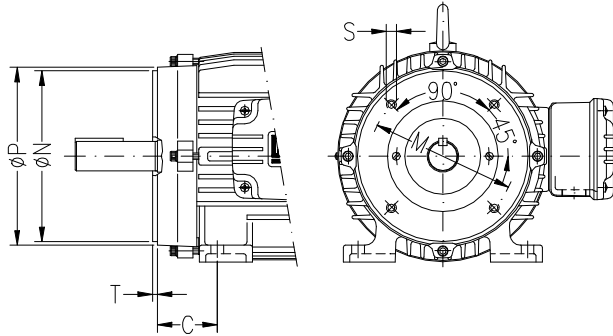

Flange 'FF'

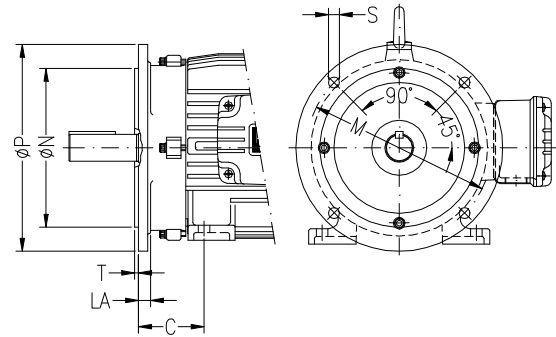

Dimensions in millimeters and inches

FRAME IEC	"C" FLANGE DIMENSIONS							n° of Holes				
	Flange	C	M	N	P	S	T					
63	FC-95	40	95.2	76.2	143	UNC	1/4"20	4				
71		1.57							3.75	3.00	5.63	0.16
80		1.77										
90S/L	FC-149	50	149.2	114.3	165	UNC	3/8"16	4				
100L		1.97										
100L	FC-184	56	184.2	215.9	225	UNC	1/2"13	6.3				
112M		2.20							7.25	8.50	8.86	0.25
132S/M		2.48										
160M/L	FC-228	70	228.6	266.7	280	UNC	1/2"13	8				
180M/L		2.76										
200M/L	FC-279	89	279.4	317.5	395	UNC	5/8"11	8				
225S/M		3.50							11.00	12.50	15.55	0.16
250S/M	4.25											
280S/M	FC-355	108	355.6	406.4	455	UNC	5/8"11	8				
315S/M		4.76							14.00	16.00	17.91	0.14
	5.24											
	FC-368	121	368.3	419.1								
		4.76							14.50	16.50		
	5.24											

IEC Frame	"FF" FLANGE DIMENSIONS										n° of Holes
	Flange	C	LA	M	N	P	T	S	a		
63	FF-115	40	9	115	95	140	3	10	45°	4	
71		1.57		4.53	3.74	5.51	0.12				
80	FF-130	45	0.35	130	110	160	3.5	0.39			
90S/L		1.77		5.12	4.33	6.30					
100L	FF-165	50	10	165	130	200	0.14	12			
112M		1.97		6.50	5.12	7.87					
132S/M	FF-215	56	11	215	180	250	4	15	45°	4	
160M/L		2.20		8.46	7.09	9.84					0.16
180M/L	FF-265	63	12	265	230	300	5	19	22°30'	8	
200M/L		2.48		10.43	9.06	11.81					0.20
225S/M	FF-300	70	18	300	250	350	0.20	0.75			
250S/M		2.76		11.81	9.84	13.78					
280S/M	FF-350	89	0.71	350	300	400	5	19			
315S/M		3.50		13.78	11.81	15.75					
355M/L	FF-400	108	22	400	350	450	6	24			
		4.25		15.75	13.78	17.72					
	FF-500	121	0.87	500	450	550	0.24	0.94			
		4.76		19.69	17.72	21.65					
	FF-600	133		600	550	660					
		5.24		23.62	21.65	25.98					
	FF-740	149		740	680	800					
		5.87		29.13	26.77	31.50					
		168		850	740	850					
		6.61		31.50	28.77	31.50					
		190		950	850	950					
		7.48		31.50	28.77	31.50					

FRAME IEC	"C" DIN FLANGE DIMENSIONS							n° of Holes
	Flange	C	M	N	P	S	T	
63	C-90	40	75	60	90	M5	2.5	4
71		1.57	2.95	2.36	3.54		0.10	
80	C-105	45	85	70	105	M6	3	
90S/L		1.77	3.35	2.76	4.13		0.12	
100L	C-120	50	100	80	120	M8	3.5	
112M		1.97	3.94	3.15	4.72		0.14	
132S/M	C-160	56	115	95	140	M10	3.5	
		2.20	4.53	3.74	5.51		0.14	
	C-200	63	130	110	160		3.5	
		2.48	5.12	4.33	6.30		0.14	
		70	165	130	200		3.5	
		2.76	6.50	5.12	7.87		0.14	
		89	165	130	200		3.5	
		3.50	6.50	5.12	7.87		0.14	



WEG Electric Motors Corporation | 1327 Northbrook Parkway | Suwanee, GA 30024 | Ph. 800-275-4934 | Fax 770-338-1632

Atlanta • Chicago • Kansas City • Los Angeles • Rochester

www.wegelectric.com