

Operator Manual

Rotary lobe blower

FBC vac SIGMA CONTROL 2

Number: 902318 03 USE

Manufacturer:

KAESER KOMPRESSOREN SE

96410 Coburg • PO Box 2143 • GERMANY • Tel. +49-(0)9561-6400 • Fax +49-(0)9561-640130

www.kaeser.com

Original instructions
/KKW/BFBCV 2.14 en Z1 SBA-GEBLAESE-SC

20220708 084935

| | | |
|----------|--|----|
| 1 | Regarding this Document | |
| 1.1 | Using this document | 1 |
| 1.2 | Further documents | 1 |
| 1.3 | Copyright | 1 |
| 1.4 | Symbols and labels | 1 |
| 1.4.1 | Warnings | 1 |
| 1.4.2 | Potential damage warnings | 2 |
| 1.4.3 | Other alert notes and their symbols | 2 |
| 2 | Technical Data | |
| 2.1 | Nameplate | 4 |
| 2.2 | Option codes | 4 |
| 2.3 | Weight | 5 |
| 2.3.1 | START CONTROL (STC) | 5 |
| 2.3.2 | OMEGA FREQUENCY CONTROL (OFC) | 6 |
| 2.4 | Drive motor | 6 |
| 2.5 | Recommended oil | 6 |
| 2.6 | Lubricating oil charge | 7 |
| 2.7 | Permitted pressure drop | 7 |
| 2.8 | Temperature | 7 |
| 2.9 | Ambient and intake conditions | 7 |
| 2.10 | Sound pressure level | 8 |
| 2.11 | Power Supply | 8 |
| 2.12 | Power supply specifications | 9 |
| 2.12.1 | START CONTROL (STC) | 9 |
| 2.12.2 | OMEGA FREQUENCY CONTROL (OFC) | 10 |
| 2.13 | Options | 11 |
| 2.13.1 | Oil level monitoring | 11 |
| 2.13.2 | Speed monitor | 11 |
| 2.13.3 | Check valve | 12 |
| 2.13.4 | Piped inlet | 12 |
| 2.13.5 | Fan (sound enclosure) | 12 |
| 2.13.6 | Exhaust silencer (pipeline) | 13 |
| 2.13.7 | Exhaust silencer (diffusion to ambient) | 13 |
| 3 | Safety and Responsibility | |
| 3.1 | Basic instructions | 14 |
| 3.2 | Specified use | 14 |
| 3.3 | Improper use | 14 |
| 3.4 | User's responsibilities | 15 |
| 3.4.1 | Observe statutory and universally accepted regulations | 15 |
| 3.4.2 | Qualified personnel | 15 |
| 3.5 | Dangers | 15 |
| 3.5.1 | Safely dealing with sources of danger | 15 |
| 3.5.2 | Safe machine operation | 17 |
| 3.5.3 | Organizational measures | 19 |
| 3.6 | Danger areas | 20 |
| 3.7 | Safety devices | 20 |
| 3.8 | Working life of safety functions | 20 |
| 3.9 | Safety signs | 21 |
| 3.10 | In emergency | 23 |
| 3.10.1 | Correct fire fighting | 23 |
| 3.10.2 | Remove lubricating oil from the skin. | 24 |
| 3.11 | Environmental protection | 24 |
| 3.12 | Warranty | 24 |

| | | |
|----------|--|----|
| 4 | Design and Function | |
| 4.1 | Machine | 25 |
| 4.2 | SIGMA CONTROL 2 operating panel | 26 |
| 4.2.1 | Keys | 26 |
| 4.2.2 | LEDs | 27 |
| 4.2.3 | RFID sensor field | 27 |
| 4.3 | Machine | 28 |
| 4.4 | Blower block | 29 |
| 4.5 | Safety relief valve | 29 |
| 4.6 | Safety devices | 30 |
| 4.7 | Compensator | 30 |
| 4.8 | Automatic starting | 30 |
| 4.9 | Floating relay contacts | 31 |
| 4.10 | Options | 31 |
| 4.10.1 | Oil level monitor | 31 |
| 4.10.2 | Speed monitor | 31 |
| 4.10.3 | Check valve | 31 |
| 4.10.4 | Piped inlet | 31 |
| 4.10.5 | Exhaust silencer (pipeline) | 31 |
| 4.10.6 | Exhaust silencer (diffusion to surroundings) | 32 |
| 5 | Installation and Operating Conditions | |
| 5.1 | Ensuring safety | 34 |
| 5.2 | Installation conditions | 34 |
| 5.2.1 | Determining installation location and clearances | 34 |
| 5.2.2 | Ensuring adequate ventilation | 36 |
| 6 | Installation | |
| 6.1 | Ensuring safety | 37 |
| 6.2 | Reporting transport damage | 38 |
| 6.3 | Anchoring the machine | 38 |
| 6.4 | Connecting the power supply | 38 |
| 6.4.1 | Under frequency control | 39 |
| 6.5 | Connecting to the vacuum network | 39 |
| 6.6 | Sound enclosure: Removing transport securing devices | 40 |
| 6.7 | Fitting the cover plate | 40 |
| 7 | Initial Start-up | |
| 7.1 | Ensuring safety | 42 |
| 7.2 | Instructions to be observed before commissioning | 43 |
| 7.3 | Checking installation and operating conditions | 43 |
| 7.4 | Re-greasing the motor bearings | 44 |
| 7.5 | Configuring the controller | 44 |
| 7.6 | Setting the display language | 44 |
| 7.7 | Checking the direction of rotation for the drive motor | 45 |
| 7.8 | START CONTROL (STC): Setting the overload protection cut-out | 46 |
| 7.9 | Starting the machine for the first time | 46 |
| 8 | Operation | |
| 8.1 | Switching on and off | 47 |
| 8.1.1 | Switching on | 47 |
| 8.1.2 | Switching off | 48 |
| 8.2 | Switching off and on in an emergency | 48 |
| 8.3 | Switching on and off from a remote control center | 49 |
| 8.4 | Switching on and off with the clock (timer) | 50 |
| 8.5 | Checking the ventilator fan function (sound enclosure) | 51 |

| | | |
|-----------|---|-----|
| 8.6 | Interpreting operation messages | 51 |
| 8.7 | Acknowledging alarm and warning messages | 51 |
| 9 | Fault Recognition and Rectification | |
| 9.1 | Basic instructions | 53 |
| 9.2 | Other faults | 53 |
| 9.3 | Sound enclosure faults | 54 |
| 10 | Maintenance | |
| 10.1 | Ensuring safety | 55 |
| 10.2 | Maintenance schedule | 56 |
| 10.2.1 | Logging maintenance work | 56 |
| 10.2.2 | Resetting maintenance interval counters | 56 |
| 10.2.3 | Regular maintenance tasks | 56 |
| 10.2.4 | Regular service tasks | 57 |
| 10.3 | Cleaning or replacing the control cabinet filter mats | 58 |
| 10.4 | Sound enclosure | 59 |
| 10.5 | Drive belt maintenance | 60 |
| 10.6 | Checking the oil level | 61 |
| 10.7 | Replenishing lubricating oil | 61 |
| 10.8 | Changing the oil | 62 |
| 10.9 | Air filter maintenance | 64 |
| 10.10 | Air filter maintenance | 64 |
| 10.11 | Machine cleaning | 65 |
| 10.12 | Motor maintenance | 65 |
| 10.12.1 | Drive motor bearings with re-greasing facility | 65 |
| 10.12.2 | Permanently greased drive motor bearings | 66 |
| 10.12.3 | Fan motor | 66 |
| 10.13 | Testing the safety relief valve | 66 |
| 10.14 | Testing the EMERGENCY STOP push button | 67 |
| 10.15 | Documenting maintenance and service work | 68 |
| 11 | Spares, Operating Materials, Service | |
| 11.1 | Note the nameplate | 69 |
| 11.2 | Ordering spares and operating fluids/materials | 69 |
| 11.3 | Replacement parts for service and repair | 69 |
| 11.3.1 | Option C33, START CONTROL (STC) | 69 |
| 11.3.2 | Option C34, OMEGA FREQUENCY CONTROL (OFC) | 72 |
| 11.4 | KAESER AIR SERVICE | 75 |
| 11.5 | Completing the contamination declaration | 75 |
| 12 | Decommissioning, Storage and Transport | |
| 12.1 | Decommissioning | 76 |
| 12.2 | Packing | 76 |
| 12.3 | Transport | 77 |
| 12.3.1 | Safety | 77 |
| 12.3.2 | Transport machine with a pallet truck or forklift truck | 77 |
| 12.4 | Storage | 77 |
| 12.5 | Disposal | 78 |
| 13 | Annex | |
| 13.1 | Pipeline and instrument flow diagram (P+I diagram) | 79 |
| 13.2 | Dimensional drawing | 82 |
| 13.3 | Sound emission | 85 |
| 13.4 | Electrical diagrams | 89 |
| 13.4.1 | Option C33, START CONTROL (STC) | 89 |
| 13.4.2 | Option C34, OMEGA FREQUENCY CONTROL (OFC) | 140 |

13.5 Project planning data 177

| | | |
|---------|--|----|
| Fig. 1 | Three-phase star (wye); 4 wire; center point solidly grounded | 9 |
| Fig. 2 | Three-phase star (wye); 3 wire; center point solidly grounded | 9 |
| Fig. 3 | Location of the safety signs on the machine | 21 |
| Fig. 4 | Safety sign location, electronically actuated components | 21 |
| Fig. 5 | Safety sign position, blow-off silencer, Option H16, H19 | 21 |
| Fig. 6 | Machine overview | 25 |
| Fig. 7 | Indicating and operating elements | 26 |
| Fig. 8 | Indicating and operating elements | 27 |
| Fig. 9 | RFID sensor field | 28 |
| Fig. 10 | Machine | 28 |
| Fig. 11 | Blower block | 29 |
| Fig. 12 | Safety relief valve | 29 |
| Fig. 13 | Compensator | 30 |
| Fig. 14 | Exhaust silencer (pipeline) | 32 |
| Fig. 15 | Exhaust silencer (diffusion to surroundings) | 33 |
| Fig. 16 | Recommended positioning of the machine, minimum dimensions [in.] | 35 |
| Fig. 17 | Removing the transport securing devices | 40 |
| Fig. 18 | Fitting the cover plate | 41 |
| Fig. 19 | Switching the machine on and off | 47 |
| Fig. 20 | Switching off in an emergency | 48 |
| Fig. 21 | Switching on and off from a remote control center | 49 |
| Fig. 22 | Switching on and off with the clock (timer) | 50 |
| Fig. 23 | Acknowledging messages | 52 |
| Fig. 24 | Control cabinet ventilation grill | 59 |
| Fig. 25 | Sound enclosure | 59 |
| Fig. 26 | Drive belt maintenance | 60 |
| Fig. 27 | Checking the oil level | 61 |
| Fig. 28 | Replenishing lubricating oil | 62 |
| Fig. 29 | Changing the oil | 63 |
| Fig. 30 | Changing the air filter | 64 |
| Fig. 31 | Maintenance of a drive motor with re-greasing facility | 66 |
| Fig. 32 | Testing the EMERGENCY STOP push button | 67 |
| Fig. 33 | Transport | 77 |

| | | |
|---------|--|----|
| Tab. 1 | Danger levels and their definition (personal injury) | 1 |
| Tab. 2 | Danger levels and their definition (damage to property) | 2 |
| Tab. 3 | Nameplate | 4 |
| Tab. 4 | Option codes | 4 |
| Tab. 5 | START CONTROL (STC) weight | 5 |
| Tab. 6 | Weight OMEGA FREQUENCY CONTROL (OFC) | 6 |
| Tab. 7 | Drive motor | 6 |
| Tab. 8 | Recommended oil | 6 |
| Tab. 9 | Lubricating oil charge | 7 |
| Tab. 10 | Temperature | 7 |
| Tab. 11 | Ambient and intake conditions | 8 |
| Tab. 12 | Connection data 208V±10% / 3 / 60Hz | 9 |
| Tab. 13 | Connection data 230V±10% / 3 / 60Hz | 10 |
| Tab. 14 | Connection data 460V±10% / 3 / 60Hz | 10 |
| Tab. 15 | Connection data 575V±10% / 3 / 60Hz | 10 |
| Tab. 16 | Connection data 460V/ 3 / 60Hz | 11 |
| Tab. 17 | Oil level monitoring (Option C5) | 11 |
| Tab. 18 | Speed monitor (Option C10) | 11 |
| Tab. 19 | Speed monitor sensor (Option C10) | 12 |
| Tab. 20 | Check valve (Option G1) | 12 |
| Tab. 21 | Fan flow rate | 12 |
| Tab. 22 | Danger areas | 20 |
| Tab. 23 | Category and Performance Level | 20 |
| Tab. 24 | Safety signs | 21 |
| Tab. 25 | Controls | 26 |
| Tab. 26 | Display elements | 27 |
| Tab. 27 | RFID sensor field | 28 |
| Tab. 28 | Recommended positioning of the machine, minimum dimensions | 35 |
| Tab. 29 | Compensator torques | 39 |
| Tab. 30 | Recommissioning after storage/standstill | 43 |
| Tab. 31 | Installation conditions check list | 43 |
| Tab. 32 | Starting frequency | 47 |
| Tab. 33 | Machine identification | 49 |
| Tab. 34 | Remote control identification | 49 |
| Tab. 35 | Machine identification | 50 |
| Tab. 36 | Other faults and remedies | 53 |
| Tab. 37 | Faults and remedies (option H12) | 54 |
| Tab. 38 | Regular maintenance tasks | 57 |
| Tab. 39 | Regular service tasks | 58 |
| Tab. 40 | Logged maintenance tasks | 68 |
| Tab. 41 | Consumable parts | 69 |
| Tab. 42 | Sound emission - legend | 85 |

1 Regarding this Document

1.1 Using this document

This operating or installation manual is part of the machine. It describes the machine as it was at the time of first delivery after manufacture.

- Keep the operating manual in a safe place throughout the life of the machine.
- Pass the operating manual on to the next owner/user.
- Ensure that all amendments received are entered or inserted in the operating manual.
- Enter details from the machine nameplate and individual items of equipment in the tables in chapter 2.

1.2 Further documents

Included with this Operating Manual are additional documents intended to assist in the safe operation of the machine:

- Manufacturer's Declaration or Declaration of Conformity according to applicable directives.
- User Manual for SIGMA CONTROL 2.

Missing documents can be requested from KAESER.

- Ensure that all documents are complete and observe the instructions contained within them.
- Ensure that you provide the data from the nameplate when ordering documents.

1.3 Copyright

This operator manual is copyright protected. Queries regarding use or duplication of the documentation should be referred to KAESER. Correct use of information will be fully supported.

1.4 Symbols and labels

- Please note the symbols and labels used in this document.

1.4.1 Warnings

Warnings indicate danger potentially resulting in personal injury, if the measures specified are not taken.

Warnings indicate three levels of danger identified by the corresponding signal word:

| Signal term | Meaning | Consequences of non-compliance |
|-------------|--|---|
| DANGER | Warns of imminent danger | Will very likely result in death or severe injury |
| WARNING | Warns of potentially imminent danger | May result in death or severe injury |
| CAUTION | Warns of a potentially dangerous situation | May result in moderate physical injury |

Tab. 1 Danger levels and their definition (personal injury)

Warning notes may precede a chapter. They apply to the entire chapter including all sub-sections.

1 Regarding this Document

1.4 Symbols and labels

Example:

⚠ DANGER

The type and source of the imminent danger is shown here!

The possible consequences of ignoring a warning are shown here.

The word "DANGER" indicates that death or severe injury can very likely result from ignoring the warning.

➤ *The measures required to protect yourself from danger are shown here.*

Warning notes referring to a sub-section or the subsequent step are integrated into the procedure and numbered as a step.

Example:

1. **⚠ WARNING** *The type and source of the imminent danger is shown here!*
The possible consequences of ignoring a warning are shown here.
The word "WARNING" indicates that death or severe injury may result from ignoring the warning.
➤ *The measures required to protect yourself from danger are shown here.*
2. Always read and comply with warning instructions.

1.4.2 Potential damage warnings

Contrary to the warnings shown above, damage warnings do not indicate potential personal injury.

Damage warnings have only one danger level, identified by this signal word:

| Signal term | Meaning | Consequences of non-compliance |
|-------------|--|--------------------------------|
| NOTE | Warns of a potentially dangerous situation | Damage to property is possible |

Tab. 2 Danger levels and their definition (damage to property)

Example:

NOTICE

The type and source of the imminent danger is shown here!

Potential effects when ignoring the warning are indicated here.

➤ *The protective measures against the damages are shown here.*

➤ Carefully read and fully comply with warnings against damages.

1.4.3 Other alert notes and their symbols



This symbol indicates particular important information.

Material Here you will find details on special tools, operating materials or spare parts.

Precondition Here you will find conditional requirements necessary to carry out the task.
The conditional requirements relevant to safety shown here will help you to avoid dangerous situations.

Option H12 ➤ This symbol is placed by lists of actions comprising one stage of a task.
Operating instructions with several steps are numbered in the sequence of the operating steps.
Information relating to one option only are marked with an option code (e.g., H12 indicates that this section applies only to machines with sound enclosure). Option codes used in this operating manual are explained in chapter 2.2.



Information referring to potential problems are identified by a question mark.
The cause is specified in the help text ...
➤ ... as is a solution.



This symbol refers to important information or measures concerning environmental protection.

Further information Further subjects are introduced here.

2 Technical Data

2.1 Nameplate

The machine's nameplate contains the model type and important technical information.

The nameplate is attached to the machine frame and on the left-hand side panel of the sound enclosure (Option H12).

The specified value for the full load current has been calculated including the associated lambda factor. This value can be found in chapter 2.12.2 (Option C34).

The information given on the nameplate relates to the standard inlet conditions of 14.7 psi and +68°F.

➤ Enter the data from the nameplate here as a reference:

| Characteristic | Value |
|--------------------------------|-------|
| Rotary lobe blowers | |
| Material no. | |
| Serial no. | |
| Ambient temperature | |
| Rated power | |
| Rated motor speed | |
| Full load current | |
| Full load current, drive motor | |
| Electrical connection | |
| Wiring diagram | |
| Year of manufacture | |

Tab. 3 Nameplate

2.2 Option codes

The table contains a list of possible options.

➤ Enter options here as a reference:

| Option | Option code | Available? |
|--|-------------|------------|
| Operating mode: Vacuum | B14 | ✓ |
| Oil level monitoring | C5 | |
| Speed monitor | C10 | |
| Unloaded start valve (AFE) | C11 | — |
| Unloaded start valve with regulating valve (AFR) | C18 | — |
| Under frequency control | C32 | |
| START CONTROL (STC) | C33 | |
| OMEGA FREQUENCY CONTROL (OFC) | C34 | |

Available: ✓

Not available: —

| Option | Option code | Available? |
|--|-------------|------------|
| Oil temperature monitoring | C39 | — |
| Communication module: PROFIBUS DP | C41 | |
| Communication module: Modbus RTU | C42 | |
| Communication module: DEVICENET | C43 | |
| Communication module: Modbus TCP | C44 | |
| Communication module: PROFINET IO | C45 | |
| Filter differential pressure switch | F5 | |
| Check valve | G1 | |
| Intake from pipe network | H11 | ✓ |
| Sound enclosure | H12 | ✓ |
| Exhaust silencer (pipeline) | H16 | |
| Exhaust silencer (diffusion to surroundings) | H19 | |
| Available: ✓ | | |
| Not available: — | | |

Tab. 4 Option codes

2.3 Weight

The values shown are maximum values. The actual weight of individual machines depends on equipment fitted.

2.3.1 Option C33 START CONTROL (STC)

| Rated power [hp] | Weight [lb] | | |
|------------------|--------------|--------------|--------------|
| | FB 441 C vac | FB 621 C vac | FB 791 C vac |
| 40.0 | 3913 | 4079 | 4420 |
| 50.0 | 3957 | 4123 | 4464 |
| 60.0 | 4023 | 4189 | 4530 |
| 75.0 | 4287 | 4453 | 4795 |
| 100.0 | 4409 | 4575 | 4916 |
| 125.0 | 4960 | 5126 | 5467 |
| 150.0 | — | 5247 | 5589 |
| — | — | — | — |
| — | — | — | — |

Tab. 5 START CONTROL (STC) weight

2.3.2 Option C34
OMEGA FREQUENCY CONTROL (OFC)

| Rated power [hp] | Weight [lb] | | |
|------------------|--------------|--------------|--------------|
| | FB 441 C vac | FB 621 C vac | FB 791 C vac |
| 40.0 | 4012 | 4178 | 4519 |
| 50.0 | 4068 | 4223 | 4575 |
| 60.0 | 4134 | 4299 | 4641 |
| 75.0 | 4453 | 4619 | 4960 |
| 100.0 | 4586 | 4751 | 5093 |
| 125.0 | 5126 | 5291 | 5633 |
| 150.0 | — | 5445 | 5787 |
| — | — | — | — |
| — | — | — | — |

Tab. 6 Weight OMEGA FREQUENCY CONTROL (OFC)

2.4 Drive motor

➤ Copy the data from the motor nameplate or service plate into the table:

| Feature | Value |
|---|-------|
| Enclosure protection | IP55 |
| Motor bearing re-greasing interval *[h] | 2000 |
| Grease requirement, each bearing [g] | |

h = operating hours

* The lubricating interval is max. 2000 h, even if a longer interval is indicated on the motor service plate.

Tab. 7 Drive motor

2.5 Recommended oil

The lubricant type to be used depends on the operating conditions.

| | OMEGA FLUID | |
|-------------|---------------|---------------|
| | SB 220 | FGB 220 |
| Description | Synthetic oil | Synthetic oil |

| | OMEGA FLUID | |
|-------------|--|---|
| | SB 220 | FGB 220 |
| Application | Suitable for all applications, except food processing. | Specifically for applications where the compressed air comes into contact with food products. |

Tab. 8 Recommended oil

Further information An adhesive label identifying the used lubricating oil is attached to the blower block and the belt guard.
 Information on ordering oil is found in chapter 11.2.

2.6 Lubricating oil charge

The block oil chambers are filled with oil at the factory.

Guide value

| | Drive-end | Gear-end |
|-----------------------------|-----------|----------|
| Lubricating oil charge [qt] | 1.1 ±15% | 1.4 ±15% |

Tab. 9 Lubricating oil charge

2.7 Permitted pressure drop

Ensure that the pressure drop in the downstream pipes is max. 0.2 psi.



The same applies to machines with exhaust silencer (pipe), option H16.

2.8 Temperature

| | FB 441 C vac | FB 621 C vac | FB 791 C vac |
|--|--------------|--------------|--------------|
| Maximum block discharge temperature [°F] | 320 | 320 | 320 |
| Maximum temperature differential [K] * | 115 | 115 | 115 |

*Discharge temperature minus inlet temperature

Tab. 10 Temperature

2.9 Ambient and intake conditions

The following conditions must be maintained:

- No salty atmosphere in the immediate vicinity of the machine.
- The air must be free of chemicals or explosive substances.

| | FB 441 C vac | FB 621 C vac | FB 791 C vac |
|--------------------------------------|--------------|--------------|--------------|
| Permissible ambient temperature [°F] | 32 – 104 | 32 – 104 | 32 – 104 |
| Permissible intake temperature [°F] | 14 – 104 | 14 – 104 | 14 – 104 |
| Relative humidity [%] | 0 – 80 | 0 – 80 | 0 – 80 |
| Maximum altitude AMSL [ft.] | 3281 | 3281 | 3281 |

Tab. 11 Ambient and intake conditions



Differing ambient and intake conditions require the recalculation of the performance data, and are permissible only upon agreement by the manufacturer.

2.10 Sound pressure level

Operating state LOAD under the following conditions:

- Nominal speed
- Nominal suction capacity
- Nominal pressure

Measuring condition according to DIN EN ISO 2151 and basic standard ISO 9614–2:

- Measurement distance: 3 ft.
- Tolerance: ± 3 dB(A)
- Sound insulated pipeline

Further information The sound pressure level and sound power level values for your machine are provided in the tables shown in chapter 13.3.

These values refer to the design condition. They do not apply to the control range with frequency converter.

2.11 Power Supply

Basic requirements

The machine is designed for an electrical supply according to National Electric Code (NEC), edition 2020, particularly article 670 and NFPA 79, edition 2021, particularly section 4.4. In the absence of any user-specified alternatives, the limits given in these standards must be adhered to. Consult manufacturer for any other specific power supply.

The incoming line within the control panel should be as short as possible.

If external sensors or communication lines are to be connected to the machine, use shielded cables and insert the same through EMC fittings into the control panel.

Three-phase

Do **NOT** operate package on any unsymmetrical power supply. Also do **NOT** operate package on power supplies such as a three phase WYE system with center point not solidly grounded or three-phase (open) delta.

The machine requires a symmetrical three-phase power supply transformer with a WYE configuration output as shown in Figure 1 and Figure 2. In a symmetrical three phase supply the phase angles and voltages are all the same.

Other power supplies are not suitable.



Fig. 1 Three-phase star (wye); 4 wire; center point solidly grounded



Fig. 2 Three-phase star (wye); 3 wire; center point solidly grounded

Further information Please contact an authorized KAESER service representative for options.
The electrical diagram 13.4 contains further specifications for electrical connection.

2.12 Power supply specifications

The following multi-strand copper core wires are given according to 2020 NEC 310.14, 310.15, 310.16 and table 310.16 adjusted for 40°C ambient temperature.

If other local conditions prevail, like for example high temperature, the cross section should be checked and adjusted according to 2020 NEC 110.14(C), 220.3, 310.14, 310.15, 310.16, 310.15(B)(1), table 310.15(C)(1), 430.6, 430.22, 430.24, 670.4(A) and other local codes.

Dual element time delay fuses are selected according to 2020 NEC 240.6, 430.52 and tables 430.52, 430.248 and 430.250.

We strongly suggest using a separate copper conductor for the equipment GROUNDING. 2020 NEC table 250.122 will point out the "minimum size", however, we recommend a ground conductor the same size as the power leads, if local codes allow.

2.12.1 Option C33 START CONTROL (STC)

Rated power supply: 208V±10% / 3 / 60Hz

| Rated power [hp] | 40.0 | 50.0 | 60.0 | 75.0 | 100.0 | 125.0 | 150.0 | — | — |
|-------------------------|------|------|------|------|-------|-------|-------|---|---|
| Backup fuse [A] | — | — | — | — | — | — | — | — | — |
| Supply line [AWG] | — | — | — | — | — | — | — | — | — |
| Current consumption [A] | — | — | — | — | — | — | — | — | — |

Tab. 12 Connection data 208V±10% / 3 / 60Hz

Rated power supply: 230V±10% / 3 / 60Hz

| Rated power [hp] | 40.0 | 50.0 | 60.0 | 75.0 | 100.0 | 125.0 | 150.0 | — | — |
|-------------------------|------|------|------|------|-------|-------|-------|---|---|
| Backup fuse [A] | — | — | — | — | — | — | — | — | — |
| Supply line [AWG] | — | — | — | — | — | — | — | — | — |
| Current consumption [A] | — | — | — | — | — | — | — | — | — |

Tab. 13 Connection data 230V±10% / 3 / 60Hz

Rated power supply: 460V±10% / 3 / 60Hz

| Rated power [hp] | 40.0 | 50.0 | 60.0 | 75.0 | 100.0 | 125.0 | 150.0 | — | — |
|-------------------------|--------|--------|--------|-------------|-------------|--------|-------------|---|---|
| Backup fuse [A] | 60.0 | 80.0 | 90.0 | 110.0 | 150.0 | 200.0 | 225.0 | — | — |
| Supply line [AWG] | 1x 4x4 | 1x 4x3 | 1x 4x2 | 1x 4x1/0 | 1x 4x3/0 | 2x 4x2 | 2x 4x1/0 | — | — |
| Current consumption [A] | 54.1 | 65.1 | 80.1 | 94.1 | 127.1 | 160.1 | 193.1 | — | — |

Tab. 14 Connection data 460V±10% / 3 / 60Hz

Rated power supply: 575V±10% / 3 / 60Hz

| Rated power [hp] | 40.0 | 50.0 | 60.0 | 75.0 | 100.0 | 125.0 | 150.0 | — | — |
|-------------------------|--------|--------|--------|--------|-------------|-------------|--------|---|---|
| Backup fuse [A] | 50.0 | 60.0 | 70.0 | 90.0 | 125.0 | 150.0 | 175.0 | — | — |
| Supply line [AWG] | 1x 4x6 | 1x 4x4 | 1x 4x3 | 1x 4x2 | 1x 4x1/0 | 1x 4x3/0 | 2x 4x2 | — | — |
| Current consumption [A] | 43.1 | 51.2 | 63.2 | 74.8 | 102.2 | 127.6 | 151.2 | — | — |

Tab. 15 Connection data 575V±10% / 3 / 60Hz

**2.12.2 Option C34
 OMEGA FREQUENCY CONTROL (OFC)**
Protective conductor requirements

Due to the leakage currents of ≥ 10 mA caused by the anti-interference capacitors in the frequency converter, a minimum diameter of 8 AWG is required for the protective conductor.

Use one of the following options if the protective conductor for the supply cable is smaller than 8 AWG:

- Multicore cable including protective conductor with a minimum cross-section of 8 AWG,
- a minimum cross-section of 8 AWG for the protective conductor alone,
- a second protective conductor with the same cross-section as the supply line,
- automatic deactivation of the power supply as soon as the protective conductor is interrupted.



Note on the lambda factor:

In addition to their fundamental oscillation, non-sinusoidal variables also contain harmonics for which no fixed phase shift angle ϕ (phi) can be specified. Instead, the power factor λ (lambda) must be used. In electrical engineering, the power factor λ denotes the ratio of the active power value P to the apparent power value S.

In the event of deviating network characteristics and therefore lambda value at the user-end, the full load current and supply cable cross-section may need to be reassessed.

Rated power supply: 460V / 3 / 60Hz

| Rated power [hp] | 40.0 | 50.0 | 60.0 | 75.0 | 100.0 | 125.0 | 150.0 | — | — |
|--|--------|--------|--------|-------------|-------------|-------------|-------------|---|---|
| Backup fuse [A] | 60.0 | 70.0 | 90.0 | 100.0 | 150.0 | 175.0 | 225.0 | — | — |
| Supply line [AWG] | 1x 4x4 | 1x 4x2 | 1x 4x2 | 1x 4x1/0 | 1x 4x2/0 | 1x 4x3/0 | 2x 4x1/0 | — | — |
| Current consumption [A] | 51.3 | 61.6 | 74.9 | 90.6 | 120.3 | 148.4 | 187.6 | — | — |
| Power factor [λ] (lambda) | 0.900 | 0.917 | 0.920 | 0.920 | 0.920 | 0.920 | 0.886 | — | — |

Tab. 16 Connection data 460V/ 3 / 60Hz

2.13 Options

Technical data for the options available for your machine are given in the following.

2.13.1 Option C5 Oil level monitoring

| Feature | Data |
|-------------------------|-----------------|
| Max. voltage [V] | 48 |
| Switching current [A] | 0.5 |
| Switching capacity [hp] | 0.03 |
| Type of contact | Normally closed |
| Degree of protection | IP67 |

Tab. 17 Oil level monitoring (Option C5)

Further information The electrical diagram in chapter 13.4 contains details of the power supply.

2.13.2 Option C10 Speed monitor

Sensor

| Feature | Data |
|--------------------------------------|------------|
| Rated switching distance S_n [in.] | 0.12–0.16 |
| Installation conditions | Not flush |
| Output function | DC PNP/NPN |

| Feature | Data |
|----------------------|-----------|
| Enclosure protection | IP 67 |
| Connection | M12 |
| Working principle | Inductive |

Tab. 18 Speed monitor (Option C10)

Sensor

| Feature | Data |
|--|--|
| Rated voltage [V] | 110 – 240 AC/DC (50 – 60 Hz) / 27 DC (typ. 24 DC) |
| Contact load capacity | 6 A (250 V AC); B300, R300 |
| Power consumption [VA] | 5 |
| Start override [s] | 0 – 1000 |
| Ambient temperature [°F] | -4 – +140 |
| Degree of protection - enclosure/terminals | IP 50 / IP 20 |
| Connection | up to 2.5 mm ² (AWG 14) |

Tab. 19 Speed monitor sensor (Option C10)

Further information The electrical diagram in chapter 13.4 contains details of the power supply.

2.13.3 Option G1 Check valve

| Nominal pipe size | Max. pressure and back pressure [psi] |
|-------------------|---------------------------------------|
| DN 200 | 21.8 |
| DN 250 | 17.4 |

Tab. 20 Check valve (Option G1)

2.13.4 Option H11 Piped inlet

The dimensional drawings in chapter 13.2 include connection dimensions.

2.13.5 Option H12 Fan (sound enclosure)

| Feature | Value |
|-------------------------|-------|
| Maximum flow rate [cfm] | 2148 |

Tab. 21 Fan flow rate

2.13.6 Option H16, H12
Exhaust silencer (pipeline)

The mounting position is shown in the dimensional drawing in chapter 13.2.

2.13.7 Option H19, H12
Exhaust silencer (diffusion to ambient)

The mounting position is shown in the dimensional drawing in chapter 13.2.

3 Safety and Responsibility

3.1 Basic instructions

The machine is manufactured to the latest engineering standards and acknowledged safety regulations. Nevertheless, dangers can arise through its operation:

- Danger to life and limb of the operator or third parties,
- Damages to the machine and other material assets.



Disregard of warning or safety instructions can cause serious injuries!

- Read the operating and installation manual carefully and take note of the contents for safe machine operation.
- Use this machine only if it is in a technically perfect condition and only for the purpose for which it is intended; observe all safety measures and the instructions in the service manual!
- Immediately rectify (have rectified) any faults that could be detrimental to safety!

3.2 Specified use

The machine is designed exclusively for the generation of vacuum in a commercial or industrial environment where air as delivery medium is approved for use. Any other use is considered incorrect. The manufacturer is not liable for any damages that may result from incorrect use. The user alone is liable for any risks incurred.

- Comply with the instructions in this operating manual.
- Operate the machine only within its performance limits and under the permitted ambient conditions.
- Operate the machine only when completely installed.

3.3 Improper use

Improper usage can cause damage to property and/or (severe) injuries.

- Only use the machine as intended.
- Use hot cooling air for heating purposes only if there is no risk to the health of humans or animals. If necessary, cooling air should be treated by suitable means.
- Do not allow the machine to take in toxic, acidic, flammable or explosive gases or vapors.
- Do not operate the machine in areas in which specific requirements with regard to explosion protection are in force.
- Intake of solid particles > 0.004 inch is not permitted.
- Persons are not allowed to remain near the exhaust outlet.
- Exhaust air must not be used for breathing purposes.

3.4 User's responsibilities

3.4.1 Observe statutory and universally accepted regulations

This is, for example, nationally implemented European directives and/or applicable national legislation, safety and accident prevention regulations.

- Observe relevant statutory and accepted regulations during installation, operation and maintenance of the machine.

3.4.2 Qualified personnel

These are people who, by virtue of their training, knowledge and experience as well as their knowledge of relevant regulations can assess the work to be done and recognize the possible dangers involved.

Authorized operators possess the following qualifications:

- Are of legal age,
- Are familiar with and adhere to the safety instructions and sections of the service manual relevant to operation,
- Have received adequate training and authorization to operate electrical and vacuum devices.

Authorized installation and maintenance personnel have the following qualifications:

- Are of legal age,
 - Have read, are familiar with and adhere to the safety instructions and sections of the service manual applicable to installation and maintenance,
 - Are completely familiar with the safety concepts and regulations of electrical and vacuum engineering,
 - Are able to recognize the possible dangers of electrical and vacuum devices and take appropriate measures to safeguard persons and property,
 - Have received adequate training in and authorization for the safe installation and maintenance of this machine.
- Ensure that personnel entrusted with operation, installation and maintenance are qualified and authorized to carry out their tasks.

3.5 Dangers

Basic instructions

Information concerning the various forms of danger that can arise during machine operation are found here.

Basic safety instructions are found in this service manual at the beginning of each chapter in the section entitled 'Safety'.

Warning instructions are found before a potentially dangerous task.

3.5.1 Safely dealing with sources of danger

The following describes the various forms of danger that can occur during machine operation.

Electricity

Touching voltage carrying components can result in electric shocks, burns or death.

- All power supplies must be fitted with lockable isolating devices by the user.
- Allow only qualified and authorized electricians or trained personnel under the supervision of a qualified and authorized electrician to carry out work on electrical equipment according to electrical engineering regulations.
- Before commissioning or re-commissioning the machine, the user must ensure adequate protection against electric shock from direct or indirect contact.
- Before starting any work on electrical equipment:
Switch off and lock out the power supply disconnecting device, and verify the absence of any voltage.
- Switch off any external power sources.
These may be connections to the electric machine heating for example.
- Use fuses corresponding to machine power.
- Regularly check that all electrical connections are tight and in proper condition.

Forces of compression

- Do not carry out welding, heat treatment or mechanical modifications on pressurized components, as this adversely affects the components' resistance to pressure.
The safety of the machine cannot be guaranteed.

Quality of discharge air

The quality of the discharge air and any substances it may contain depends on the quality of the air drawn from the vacuum network.

- Never breathe in exhaust air.
- Lead exhaust air outdoors to a point far from any persons.

Spring forces

Springs under tension or compression store energy. Uncontrolled release of this energy can cause serious injury or death.

Safety relief valves are heavily spring-loaded.

- Do not open or dismantle any valves.

Rotating components

Touching the fan wheel or the belt drive while the machine is running can result in serious injury.

- Do not remove separating protective installations when the machine is running.
- Switch off and lock out the power supply disconnecting device, and verify the absence of any voltage.
- Wear close-fitting clothes and a hair net if necessary.
- Ensure that all covers and safety guards are in place and secured before re-starting.

Temperature

High temperatures are generated during compression. Touching hot components may cause injuries.

- Switch off and lock out the power supply disconnecting device and verify the absence of any voltage.
- Wear close-fitting clothes and a hair net if necessary.
- Ensure that all covers and safety guards are in place and secured before re-starting.

Noise

The sound enclosure absorbs the machine noise to a tolerable level. This function will be effective only if the sound enclosure is closed.

- Wear hearing protection if necessary.

Operating fluids/materials

The used operating fluids and materials can cause adverse health effects. Suitable safety measures must be taken in order to prevent injuries.

- Strictly forbid fire, open flame and smoking.
- Follow safety regulations when dealing with oils, lubricants, and chemical substances.
- Avoid contact with skin and eyes.
- Do not inhale oil mist and vapors.
- Do not eat or drink while handling lubricants.
- Keep suitable fire extinguishing agents ready for use.
- Use only KAESER approved operating materials.

Unsuitable spare parts

Unsuitable spare parts compromise the safety of the machine.

- Use only spare parts approved by the manufacturer for use in this machine.
- Use only genuine KAESER replacement parts on pressure bearing parts.

Conversion or modification of the machine

Modifications, additions or conversions to or of the machine can result in unpredictable hazards.

- Do not convert or modify the machine!
- Prior to any technical modification and expansions of the machine, obtain the written approval of the manufacturer.

Extending or modifying the compressor station

If dimensioned appropriately, safety relief valves reliably prevent an impermissible rise in pressure. New dangers may arise if you modify or extend the compressor station.

- When extending or modifying the compressor system:
Check the blow-off capacity of the safety relief valves prior to installing the new machine.
- If the blow-off capacity is insufficient:
Install safety relief valves with larger blow-off capacity.

3.5.2 Safe machine operation

The following is information supporting you in the safe handling of the machine during individual product life phases.

Personal protective equipment

When working on the machine you may be exposed to dangers that can result in accidents with severe adverse health effects.

- Wear protective clothing as necessary.

Suitable protective clothing (examples):

- Safety work wear
- Protective gloves
- Safety boots
- Eye protection
- Ear protection

Transporting

The weight and size of the machine require safety measures during its transport to prevent accidents.

- Use suitable lifting gear that conforms to local safety regulations.
- Allow transportation only by personnel trained in the safe movement of loads.
- Attach lifting gear only to suitable lifting points.
- Be aware of the center of gravity to avoid tipping.
- Make sure the danger zone is clear of personnel.
- Do not step onto machine components to climb up the machine.

Assembly

- Make sure no power is applied when electrical connections are made.
- Use only electrical cables that are suitable and approved for the surroundings and electrical loads applied.
- Attach or detach pipework only with the machine at atmospheric pressure.
- Use only pressure lines that are suitable and approved for the maximum working vacuum and the intended medium.
- Do not allow connection pipes to be placed under mechanical stress.
- Do not induce any forces into the machine via the connections, so that the compressive forces must be balanced by bracing.
- Do not step onto machine components to climb up the machine.

Installation

A suitable installation location for the machine prevents accidents and faults.

- Install the machine in a suitable compressor room.
- Ensure sufficient and suitable lighting such that the display can be read and work carried out comfortably and safely.
- Ensure accessibility so that all work on the machine can be carried out without danger or hindrance.
- If installed outdoors, the machine must be protected from frost, direct sunlight, dust, rain and splashing water.
- Do not operate in areas in which specific requirements with regard to explosion protection are in force.

- Ensure adequate ventilation.
- Place the machine in such a manner that the working conditions in its environment are not impaired.
- Comply with limit values for ambient temperature and humidity.
- The intake air must not contain any damaging contaminants, Damaging contaminants are for instance: explosive or chemically instable gases and vapors, acid or base forming substances such as ammonia, chlorine or hydrogen sulfide.
- Do not position the machine in the warm exhaust air flow from other machines.
- Keep suitable fire extinguishing agents ready for use.

Commissioning, operation and maintenance

During commissioning, operation and maintenance you may be exposed to dangers resulting from, e.g., electricity, pressure and temperature. Careless actions can cause accidents with severe adverse effects for your health.

- Allow maintenance work to be carried out only by authorized personnel.
- Wear close-fitting, flame-resistant clothing. Wear protective clothing as necessary.
- Switch off and lock out the power supply disconnecting device, and verify the absence of voltage.
- Check that there is no voltage on floating relay contacts.
- Vent all components and chambers under vacuum to atmospheric pressure.
- Allow the machine to cool down.
- Do not open the sound enclosure while the machine is switched on.
- Do not open or dismantle any valves.
- Use only spare parts approved by KAESER for use in this machine.
- Carry out regular inspections:
for visible damage,
of safety installations,
of the EMERGENCY STOP push button,
of any components requiring monitoring.
- Pay particular attention to cleanliness during all maintenance and repair work. Cover components and openings with clean cloths, paper or tape to keep them clean.
- Do not leave any loose components, tools or cleaning rags on or in the machine.
- Components removed from the machine can still be dangerous.
Do not attempt to open or destroy any components taken from the machine.

Decommissioning, storage and disposal:

Improper handling of old operating fluids and components represent a danger for the environment.

- Drain off fluids and dispose of them according to applicable environmental regulations. These include, for example, lubricating oil.
- Dispose of the machine in accordance with local environmental regulations.

3.5.3 Organizational measures

- Designate personnel and their responsibilities.
- Give clear instructions on reporting faults and damage to the machine.
- Give instructions on fire reporting and fire-fighting measures.

3.6 Danger areas

The table gives information on areas dangerous to personnel.

Only authorized personnel may enter these areas.

| Function | Danger area | Authorized personnel |
|--------------|---|---|
| Transporting | Within a 10 ft radius of the machine. | Installation personnel for transporting preparation. No personnel during transporting. |
| | Beneath the lifted machine. | No personnel! |
| Installation | Within the machine. Within 3 ft radius of the machine and its power supply cables. | Installation personnel |
| Operation | Within a 3 ft radius of the machine. | Operating personnel |
| Maintenance | Within the machine. | Maintenance personnel |
| | Within a 3 ft radius of the machine. | |

Tab. 22 Danger areas

3.7 Safety devices

Various safety devices ensure safe working with the machine.

- Do not change, bypass or disable safety devices.
- Check safety devices for correct function regularly.
- Do not remove or obliterate labels and notices.
- Ensure that labels and notices are clearly legible.

Further information More information on safety devices is contained in chapter 4, section 4.6.

3.8 Working life of safety functions

Pursuant to ISO 13849-1:2015, Category and Performance Level (PL) of the machine's safety functions have been analyzed and assessed:

| Safety function | Category | Performance Level |
|----------------------------|----------|-------------------|
| EMERGENCY STOP push button | 1 | c |

Tab. 23 Category and Performance Level

The safety-relevant functions of the safety devices are designed for a working life of 20 years. The working life starts with the original machine commissioning, and is not extended by times during which the machine was not in use.

The following components are affected:

- EMERGENCY STOP push button
- Option C33, START CONTROL (STC):
Star-delta contactor combination
- Option C34, OMEGA FREQUENCY CONTROL (OFC):
Frequency converter

1. The functions of the safety devices must be replaced by KAESER SERVICE after a working life of 20 years.
2. Have an authorized KAESER service representative check the reliability of the safety functions.

3.9 Safety signs

The illustration shows the location of the safety signs on the machine. Table 24 lists the various safety signs used and their meanings.

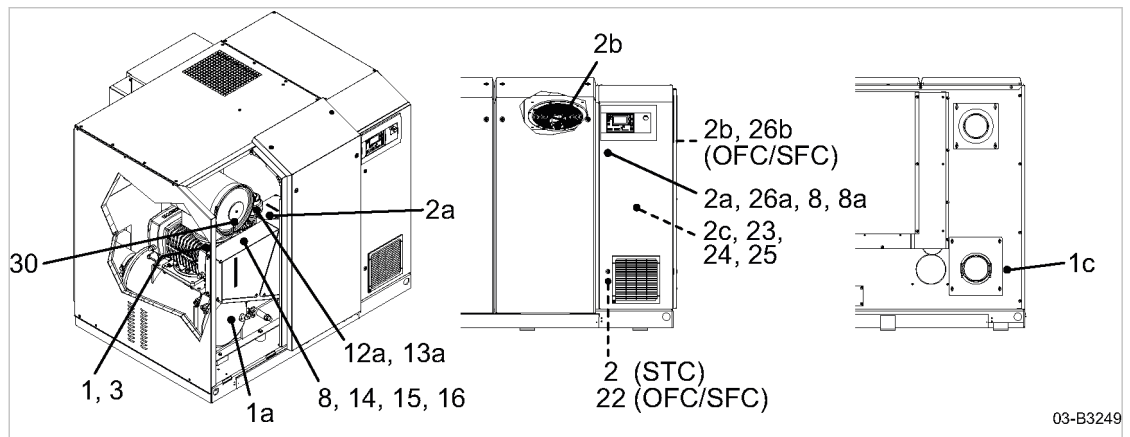

Fig. 3 Location of the safety signs on the machine

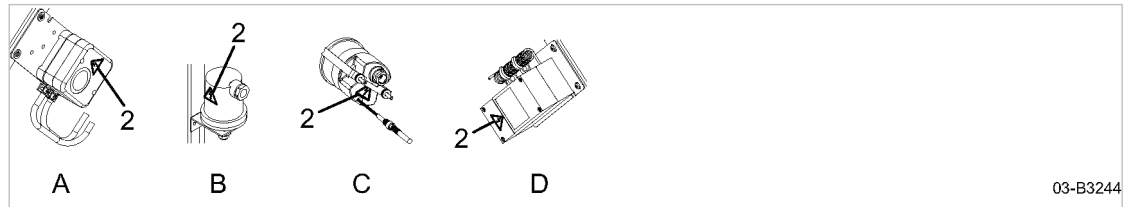

Fig. 4 Safety sign location, electronically actuated components

- | | |
|---|--|
| (A) Filter differential pressure switch | (C) Temperature display with switching point |
| (B) Pressure switch | (D) Thermostat |

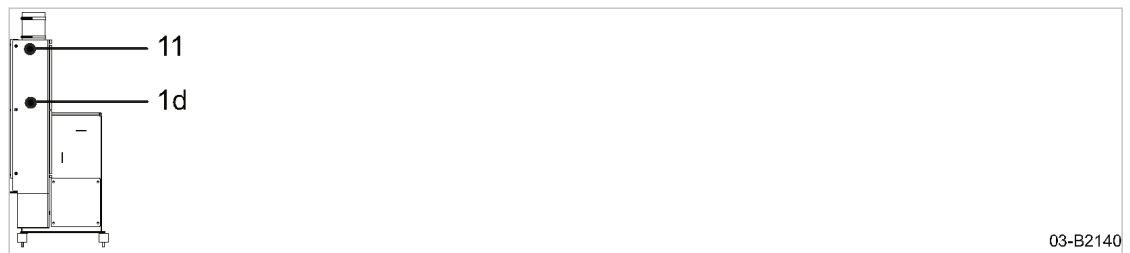

















Fig. 5 Safety sign position, blow-off silencer, Option H16, H19

| Location | Symbol | Meaning |
|---------------------|--------|--|
| 1 1a 1c 1d | | Hot surface can cause burns! ➤ Let the machine cool down. ➤ Wear long-sleeved garments (not synthetics such as polyester) and protective gloves. |

| Location | Symbol | Meaning |
|---------------------|---|--|
| 2 2a 2b 2c |  | Danger of fatal injury from touching electrically live components! <ul style="list-style-type: none"> ➤ Switch off and lock out / tag out the power supply disconnecting device and verify the absence of any voltage before opening any machine enclosure or guard. |
| 3 |  | Rotating rotors! Risk of serious lacerations or even severing of extremities (fingers) from rotating components. <ul style="list-style-type: none"> ➤ Operate the machine only when a connection is made to the inlet port. ➤ Switch off and lock out / tag out the power supply disconnecting device and verify the absence of any voltage before opening any machine enclosure or guard. |
| 8 |  | Personal injury or damage to the machine by incorrect operation! <ul style="list-style-type: none"> ➤ Read and understand the service manual and all safety signs before switching on this machine. |
| 8a |  | Machine starts automatically! Severe injury can result from rotating components, electrical voltage, and air pressure. <ul style="list-style-type: none"> ➤ Switch off and lock out / tag out the power supply disconnecting device and verify the absence of any voltage before opening any machine enclosure or guard. |
| 11 |  | Hot gas! Burning, from contact with hot gasses. <ul style="list-style-type: none"> ➤ Do not enter danger zone. ➤ Wear long-sleeved garments (not synthetics such as polyester) and protective gloves. |
| 12a |  | Serious injury or death can result from loosening or opening component that is under pressure and heavily spring loaded! <ul style="list-style-type: none"> ➤ Do not open or dismantle the valve. ➤ Contact an authorized KAESER service representative if a fault occurs. |
| 13a |  | Serious injury or death can result from loosening or opening component under pressure! <ul style="list-style-type: none"> ➤ Depressurize all pressurized components and enclosures. ➤ Ensure the machine remains depressurized. ➤ Check that machine is depressurized. |
| 14 |  | Severe injury could result from touching the v-belt drive while it is rotating! <ul style="list-style-type: none"> ➤ Switch off and lock out / tag out the power supply disconnecting device and check that no voltage is present. |
| 15 |  | Injury and/or contamination can result from breathing compressed air! Contamination of food can result from using untreated compressed air for food processing! <ul style="list-style-type: none"> ➤ Never breathe untreated compressed air. ➤ Air from this compressor must meet OSHA 29CFR1910.134 and FDA 21CFR178.3570 standards, if used for breathing or food processing. Use proper compressed air treatment. |

| Location | Symbol | Meaning |
|------------|---|---|
| 16 |  | Noise due to opened service panel of the sound enclosure (Option H12)! ► Hearing may be damaged. ► Wear hearing protection. |
| 22 |  | High protective conductor current! Touching electrically live components can cause serious injury or death. ► Switch off and lock out / tag out the power supply disconnecting device and check that no voltage is present. ► Wait at least 5 minutes. ► Verify the absence of any voltage. |
| 23 |  | Danger of fatal injury from touching electrically live components! ► Switch off and lock out / tag out the power supply disconnecting device and verify the absence of any voltage. |
| 24 |  | Risk of electric shock! ► If the interrupter has tripped current-carrying components of the controller should be examined and replaced if damaged to reduce the risk of fire or electric shock. |
| 25 |  | Risk of electric shock! ► To maintain high current short-circuit, and ground-fault protection, the manufacturer's instructions for setting the interrupter must be followed to reduce the risk of fire or electric shock. |
| 26a 26b |  | Danger of fatal injury from electrical voltage and charged capacitors! ► Before starting any work on the electrical equipment: Switch off the power supply disconnecting device, lock out / tag out the device, verify the absence of any voltage. ► Following shutdown of the power supply disconnecting device, wait for 5 minutes before opening the control cabinet/connector box. ► Before starting work on the frequency converter or intermediate circuit capacitors, wait for at least 5 minutes. |
| 30 |  | Danger of bursting from excessive pressure! ► Always remove the inlet silencer cover when checking the direction of rotation. |

Tab. 24 Safety signs

3.10 In emergency

3.10.1 Correct fire fighting

Suitable extinguishing agents

- Foam
- Carbon dioxide
- Sand or dirt

Unsuitable or unsafe extinguishing agents

- Strong jet of water

1. Keep calm.
2. Give the alarm.
3. Switch off the power supply disconnecting device, if possible.
4. Move to safety.
 - Warn persons in danger.
 - Help incapacitated persons.
 - Close the doors.
5. Try to extinguish the fire if you have the skill to do so.

3.10.2 Remove lubricating oil from the skin.

- Eye contact:
Rinse eyes thoroughly with lukewarm water and seek medical assistance.
- Skin contact:
Wash off immediately.

3.11 Environmental protection

- Store and dispose of operating materials and replaced parts in accordance with local environmental protection regulations.
- Observe national regulations.
This applies particularly to parts contaminated with lubricating oil.



- Do not allow lubricating oil to escape to the environment or into the sewage system.

3.12 Warranty

This operator manual contains no independent warranty commitment. Our general terms and conditions of business apply with regard to warranty.

A condition of our warranty is that the machine is used for the purpose for which it is intended under the conditions specified.

Due to the multitude applications for which the machine is suitable the obligation lies with the user to determine its suitability for his specific application.

In addition, we accept no warranty obligation for:

- the use of unsuitable parts or operating materials,
- unauthorized modifications,
- incorrect maintenance,
- incorrect repair.

Correct maintenance and repair includes the use of original spare parts and operating materials.

- Obtain confirmation from KAESER that your specific operating conditions are suitable.

4 Design and Function

4.1 Machine

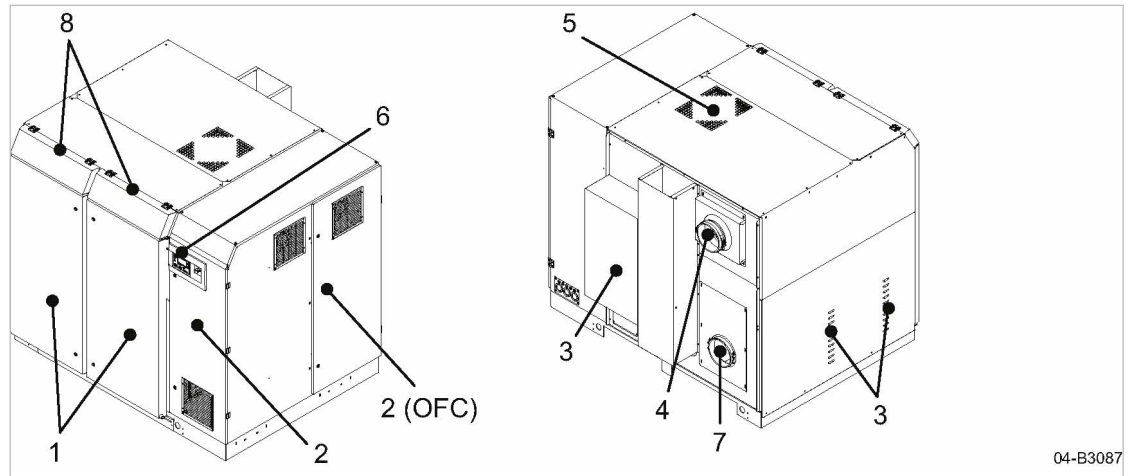

Fig. 6 Machine overview

- | | | | |
|---|----------------------|---|----------------------------|
| ① | Access door | ⑤ | Cooling air outlet |
| ② | Control cabinet door | ⑥ | Controller SIGMA CONTROL 2 |
| ③ | Cooling air inlet | ⑦ | Exhaust air outlet |
| ④ | Intake air inlet | ⑧ | Flip panels |

The sound enclosure has access panels ① and flip panels ⑧ that can be opened.

The control cabinet door ② can be swung open.

Latches are released by a key supplied with the machine.

The sound enclosure has several functions when it is closed:

- Sound insulation
- Airflow control

The sound enclosure is not suitable for the following uses:

- Walking on, standing on or sitting on.
- Use as a resting place or storage of any kind of load.

Process air flow

Intake air is drawn into the inlet silencer via the intake line.

Air is discharged through the exhaust air outlet ⑦.

Cooling air flow

The drive motor fan draws cooling air through the cooling air inlet ③ into the sound enclosure to cool the drive motor and the machine.

Cooling air flow is boosted by a fan within the sound enclosure. The warm air is expelled to the exterior in order to prevent the machine from overheating.

4.2 SIGMA CONTROL 2 operating panel

4.2.1 Keys

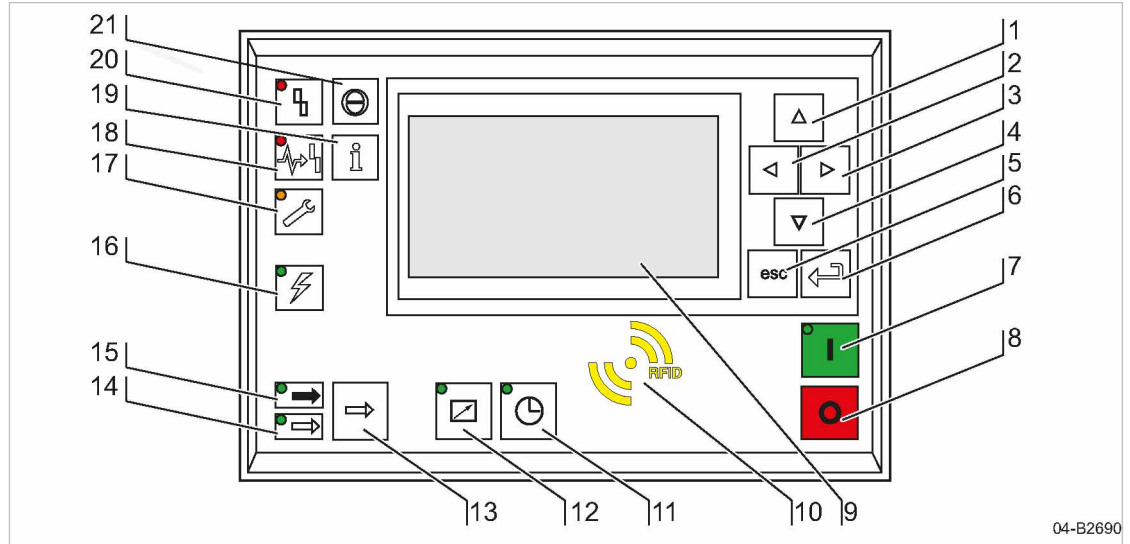

Fig. 7 Indicating and operating elements

| Item | Name | Function |
|------|------------------------|--|
| ① | «Up» | Scrolls up the menu options. Increases a parameter value. |
| ② | «Left» | Jumps to the left. Moves the cursor position to the next left field. |
| ③ | «Right» | Jumps to the right. Moves the cursor position to the next right field. |
| ④ | «Down» | Scrolls down the menu options. Reduces a parameter value. |
| ⑤ | «Escape» | Returns to the next higher menu option level. Exits the Edit mode without saving. |
| ⑥ | «Enter» | Jumps to the selected menu option. Exits the Edit mode and saves. |
| ⑦ | «ON» | Switches the machine on. |
| ⑧ | «OFF» | Switches the machine off. |
| ⑩ | RFID | RFID sensor field for user log-in with RFID Equipment Card. |
| ⑪ | «Timer control» | Switches timer control on and off. |
| ⑫ | «Remote control» | Switches remote control on and off. |
| ⑬ | «LOAD/IDLE» | Toggles between the LOAD and IDLE operating modes. |
| ⑰ | «Information & Events» | Displays the event memory. |
| ⑳ | «Reset» | Signifies recognition of alarms and warning messages. If permissible: Resets the fault counter (RESET). |

Tab. 25 Controls

4.2.2 LEDs

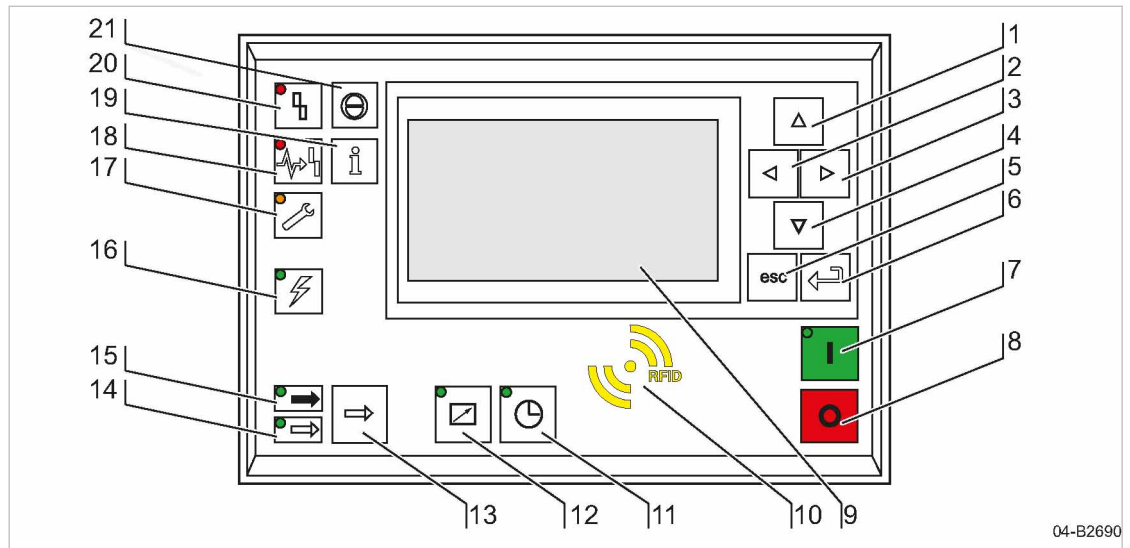

Fig. 8 Indicating and operating elements

| Item | Name | Function |
|------|----------------------|--|
| 7 | ON | Display illuminates green when the machine switched on. |
| 9 | Display | Graphic display with 8 lines and 30 characters per line. |
| 11 | Timer control | Continuous green light when the machine is controlled by the timer. |
| 12 | Remote control | Continuous green light when the machine is in remote control. |
| 14 | IDLE | Continuous green light when the machine is running in IDLE. Flashes when the «LOAD/IDLE» toggle key is pressed. |
| 15 | LOAD | Continuous green light when the machine is running in LOAD. |
| 16 | Controller on | Continuous green light when voltage is applied to the controller. |
| 17 | Warning | Flashes in yellow in the following events: <ul style="list-style-type: none"> ■ Maintenance necessary. ■ Warning message |
| 18 | Communications error | Continuous red light to indicate a faulty communication connection without machine shut-down. |
| 20 | Fault | Flashes red to indicate a machine fault. Continuous red light after acknowledgement. |

Tab. 26 Display elements

4.2.3 RFID sensor field

RFID is the abbreviation for “Radio Frequency Identification” and enables the identification of persons or objects.

Placing a suitable transponder in front of the RFID sensor field of the controller will automatically activate the communication between transponder and SIGMA CONTROL 2.

A suitable transponder is the RFID Equipment Card. Two of them have been provided with the machine.

Typical application:

- Operators log on at the machine.
(Manual input of the password not required)



The RFID Equipment Cards are carefully packed in a plastic sleeve. This plastic sleeve is attached to the rear of the controller in the control cabinet.

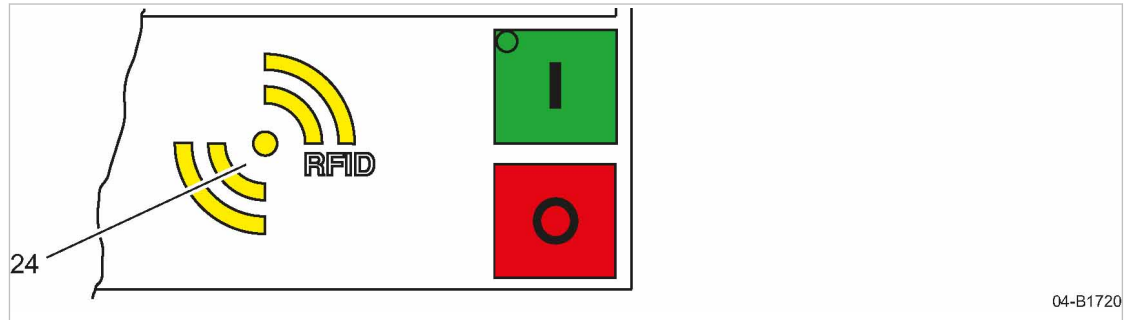

Fig. 9 RFID sensor field

| Item | Name | Function |
|------|------|---|
| 24 | RFID | RFID sensor field for the communication with a RFID Equipment Card or RFID Key. |

Tab. 27 RFID sensor field

Further information More information about the use of RFID technology is provided in the SIGMA CONTROL 2 operating manual.

4.3 Machine

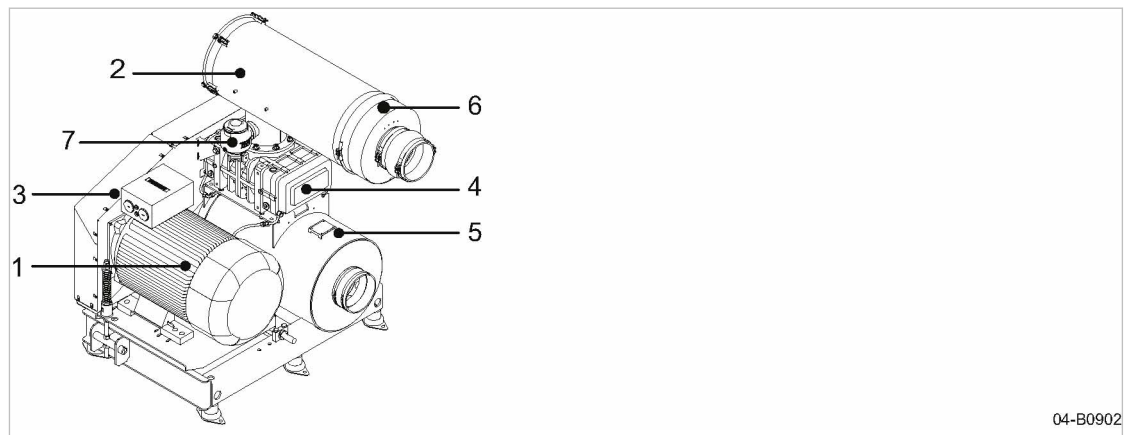

Fig. 10 Machine

- | | |
|------------------|---------------------------|
| ① Drive motor | ⑤ Outlet silencer |
| ② Inlet silencer | ⑥ Check valve (Option G1) |
| ③ Belt guard | ⑦ Safety relief valve |
| ④ Blower block | |

The drive motor (electric motor) ① drives the blower block ④ via a belt drive. Air is drawn into the inlet silencer ② via an air filter where it is cleaned.

The air is then pushed from the blower block in a vertical direction into the outlet silencer (5), where the process induces pressure build-up.

4.4 Blower block

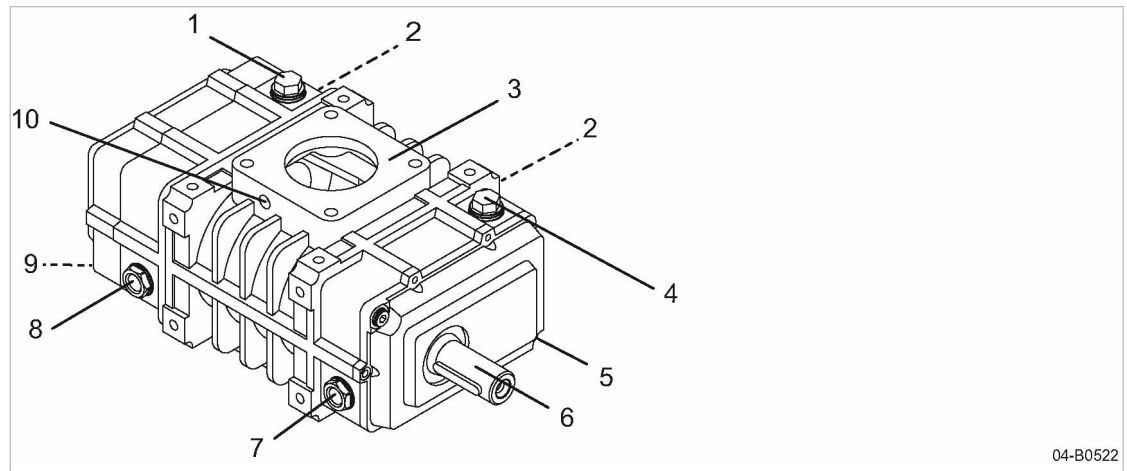

Fig. 11 Blower block

- | | |
|----------------------------------|--|
| ① Gear-end oil inlet | ⑥ Drive shaft |
| ② Side gas drainage (closed) | ⑦ Drive-end oil sight glass |
| ③ Flange connection (both sides) | ⑧ Gear-end oil sight glass |
| ④ Drive-end oil inlet | ⑨ Gear-end oil drain |
| ⑤ Drive-end oil drain | ⑩ Connection for measuring instrument (both sides) |

A pair of rotors with intermeshing lobes turn in opposite directions within a casing. The rotors are synchronized by timing gears on one end. Air in the block inlet is trapped between the rotor lobes and the casing and moved round to the discharge port.

As there is no contact between the rotors themselves and the casing, oil film lubrication is not required.

4.5 Safety relief valve

The safety relief valve protects the vacuum system from excessive vacuum. It is factory set.

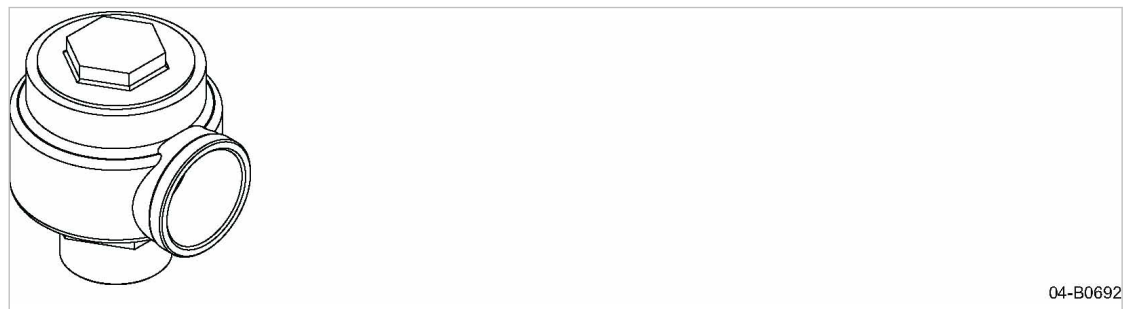

Fig. 12 Safety relief valve

4.6 Safety devices

The following safety devices are provided and may not be modified in any way:

- Safety relief valve:
This valve protects the vacuum system from excessive vacuum. It is factory set.
- Covers over moving parts and electrical connections:
These protect against accidental contact.
- Sound enclosure (Option H12):
The sound enclosure prevents excessive noise emission.
- Drive motor with 3 PTC thermistors:
Motor protection against overheating in connection with the user's protection cut-out.

4.7 Compensator

The compensator functions as follows:

- Inlet and outlet connections to silencers and accessories
- Isolates the machine vibrations from the air pipeline

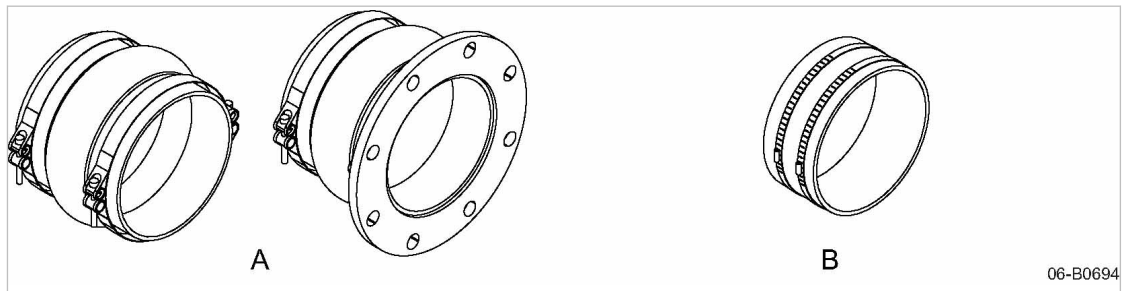

Fig. 13 Compensator

- (A) Compensator, suction side
- (B) Compensator, exhaust side

4.8 Automatic starting

Depending on the settings in the controller, the machine can automatically start after a power failure or external deactivation.

You must be logged in with the RFID Equipment Card in order to activate or deactivate this option. Option deactivated (factory setting):

- Machine remains deactivated after a network power failure.

Option activated:

- Machine automatically restarts after the voltage supply has returned.

Further information Note the instructions in the operating manual supplied with SIGMA CONTROL 2 for activating and deactivating this function.

4.9 Floating relay contacts

Floating relay contacts are provided for the transfer of operational state (messages). Information on location, loading capacity, and type of contact can be found in the electrical diagram.



If the floating relay contacts are connected to an external voltage source, voltage may be present even when the machine is isolated from the power supply.

4.10 Options

The options available for your machine are described below.

4.10.1 Option C5 Oil level monitor

The oil level switch monitors the level of lubricating oil in the blower block. This electronic monitoring does not relieve the obligation to perform regular manual checks of the lubricating oil level.

Two float-type level sensors monitor the level of oil in the drive and gear-end oil chambers. If the oil level falls below the minimum level, a switching contact is opened.

The controller registers the signal, displays an alarm message and shuts down the machine.

4.10.2 Option C10 Speed monitor

The speed monitor measures the rotational speed of the block rotors.

If the set minimum speed is not reached, the controller displays an alarm message and shuts down the machine.

4.10.3 Option G1 Check valve

The check valve prevents a reversal of the normal air flow direction.

The valve is closed when the machine is at standstill.

The check valve is integrated in the intake silencer.

4.10.4 Option H11 Piped inlet

Air is drawn into the block through the inlet silencer.

4.10.5 Option H16, H12 Exhaust silencer (pipeline)

The exhaust silencer reduces noise emission.

⚠ WARNING

Danger of burns from hot components!

- *Wear long-sleeved clothing and protective gloves.*

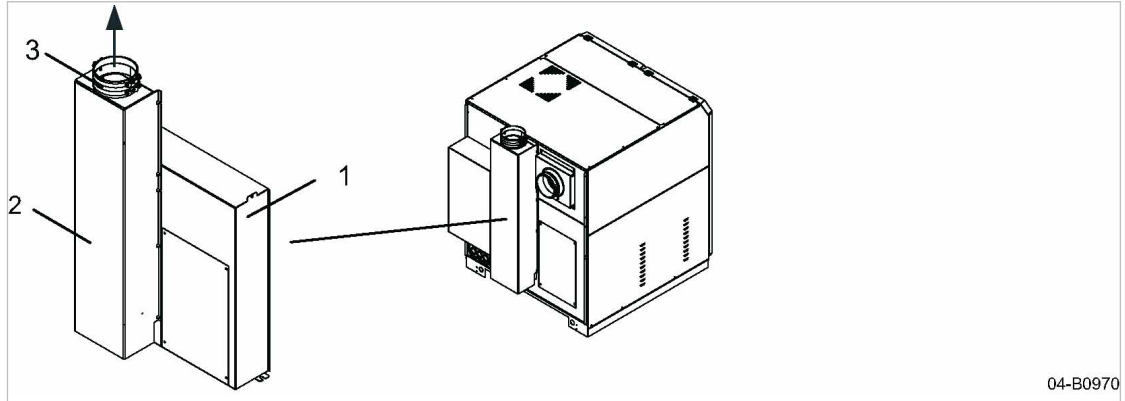

Fig. 14 Exhaust silencer (pipeline)

- ① Silencer
- ② Exhaust air duct
- ③ Compensator
(connection to pipeline)

The exhaust air generated during the compression (vacuum) process passes through a compensator ③ on the silencer ① into a flexible pipeline.

The exhaust air can reach temperatures up to a max. of 320°F in the silencer.

4.10.6 Option H19, H12 Exhaust silencer (diffusion to surroundings)

The exhaust silencer reduces noise emission.

⚠ WARNING

Danger of burning from hot components and scalding from escaping oil.

- *Wear long-sleeved clothing and protective gloves.*
- *Do not inhale the exhaust air.*

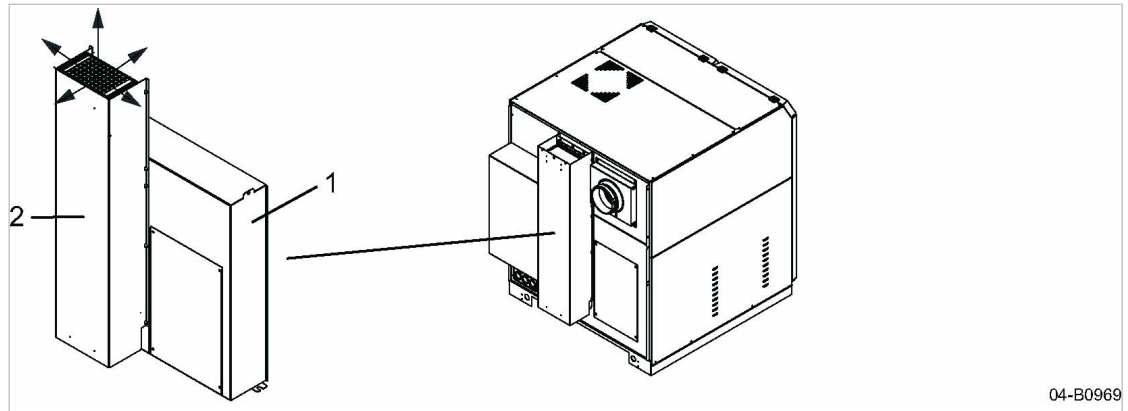

Fig. 15 Exhaust silencer (diffusion to surroundings)

- ① Silencer
- ② Exhaust air duct

The exhaust air generated during the compression (vacuum) process is diffused out through the silencer ② into the surrounding atmosphere.

The exhaust air may reach temperatures up to a max. of 320°F.

5 Installation and Operating Conditions

5.1 Ensuring safety

The conditions in which the machine is installed and operated have a decisive impact on safety. Warning instructions are located before a potentially dangerous task.



Disregard of warning instructions can cause serious injuries!

Complying with safety instructions

Disregard of safety warnings can cause unforeseeable dangers!

- Strictly forbid fire, open flame and smoking.
- If welding is carried out on or near the machine, take adequate measures to prevent sparks or heat from igniting oil vapors or parts of the machine.
- Do not store flammable material in the vicinity of the machine.
- The machine is not explosion-proof!
Do not operate in areas in which specific requirements with regard to explosion protection are in force.
- Ensure sufficient and suitable lighting such that the display can be read and work carried out comfortably and safely.
- Keep suitable fire extinguishing agents ready for use.
- Comply with the permissible ambient and intake conditions.
- Ensure the correct composition of the intake air:
 - Clean with no damaging contaminants (e.g., dust, fibers, fine sand).
 - Free of explosive or chemically unstable gases or vapors.
 - Free of acid/alkaline forming substances, particularly ammonia, chlorine or hydrogen sulfide.

Noise

The sound enclosure absorbs and reduces the machine noise to a comfortable level. This function will be effective only if the sound enclosure is closed.

- If necessary, wear hearing protection or take hearing protection measures on-site.

5.2 Installation conditions

5.2.1 Determining installation location and clearances

The machine is intended for installation in a suitable machine room. Information on wall clearances and ventilation is given below.



The clearances specified are recommended clearances and ensure unhindered access to all machine parts.

- Please consult KAESER if you cannot comply with these recommendations.

Precondition The floor must be level, firm and capable of bearing the weight of the machine. No special foundations are necessary.

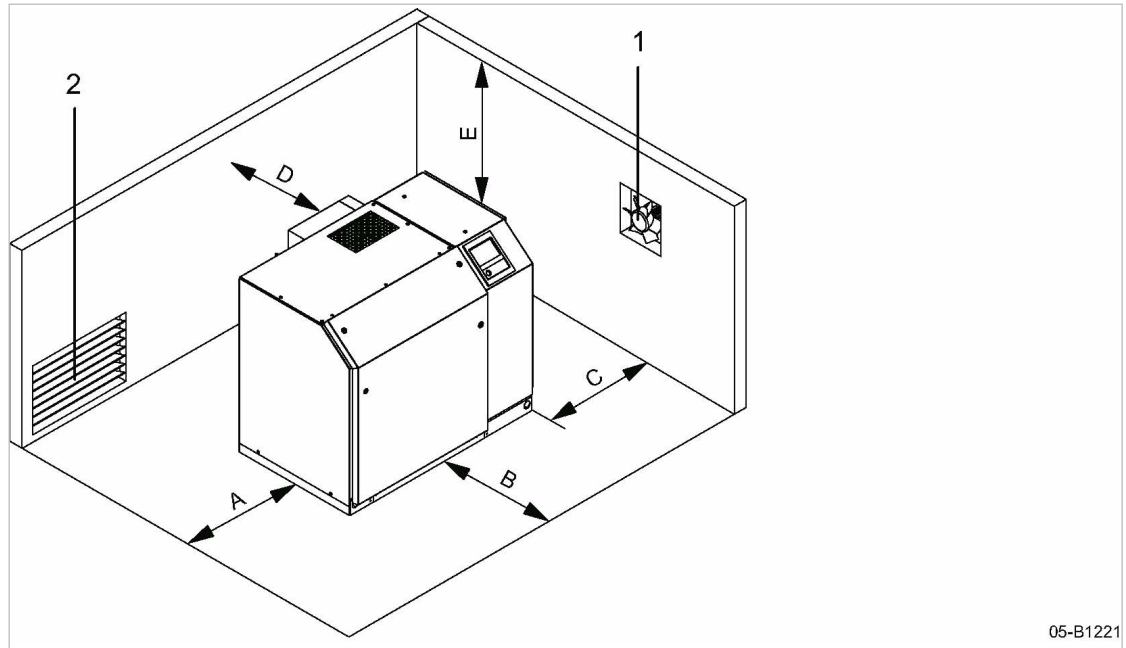

05-B1221

Fig. 16 Recommended positioning of the machine, minimum dimensions [in.]

- | | |
|------------------|-----------------------------------|
| (A) See Table 28 | (E) 32.0 |
| (B) 51.2 | (1) Exhaust fan |
| (C) See Table 28 | (2) Ventilation inlet air opening |
| (D) 39.4 | |

➤ Determine clearances (A) and (C).

| Characteristic, option | Recommended positioning of the machine, minimum dimensions |
|---------------------------------------|--|
| C33, START CONTROL (STC) | Distance (A) or (C) must be a minimum of 27.6 in.. Version 1: (A) = 2.4 in. and (C) = 27.6 in. Version 2: (A) = 27.6 in. and (C) = 2.4 in. |
| C34, OMEGA FREQUENCY CONTROL (OFC) | (A) = 2.4 in. (C) = 29.5 in. |

Tab. 28 Recommended positioning of the machine, minimum dimensions

- If the ambient temperature is too low: Ensure that the compressor room is adequately heated.
- Ensure accessibility so that all work on the machine can be carried out hazard-free and without obstruction.
- Do not position the machine in the hot exhaust air flow from other machines.
- When installing multiple machines, ensure that all inlet and exhaust air openings are arranged on one side.
- Observe any additional clearances that may be specified in local occupational health & safety and building regulations, so that escape and rescue routes may safely be accessed, even when the machine enclosure is open.

5.2.2 Ensuring adequate ventilation

If the ventilation is insufficient, a partial vacuum can be created in the machine room.

- Ensure that the flow rate of inlet air is at least the same as the flow rate taken by the machine and exhaust fan from the machine room.
- Ensure that a sufficient amount of oxygen is available for any individuals entering the machine room.
- Ensure that the machine and exhaust fan can only be operated when the ventilation inlet air opening is open.
- Keep the inlet and exhaust openings free from obstructions so that the cooling air can flow freely through the machine room.

6 Installation

6.1 Ensuring safety

Follow these instructions to ensure safe installation.

Warning instructions are provided prior to any potentially dangerous task.



Disregard of warning instructions can result in life-threatening injuries!

Observing safety warnings

Ignoring safety warnings can result in unforeseen dangers.

- Follow the instructions in chapter 3 "Safety and Responsibility".
- Installation work must only be carried out by authorized personnel!
- Ensure that no personnel are working on the machine.
- Ensure that all cover panels are closed.

Working on live components

Touching live components can result in electric shocks, burns or death.

Dangerous voltages remain in the frequency converter and intermediate circuit capacitors for some time after the power has been disconnected.

When the frequency converter is open, live components are exposed.

- Work on electrical equipment may only be carried out by authorized electricians.
- Switch off the power supply disconnecting device, lock out / tag out the device, verify the absence of any voltage.
- Before starting work on the frequency converter or intermediate circuit capacitors, wait for at least 5 minutes.
- Check that there is no voltage on floating contacts.

Working at the vacuum system

The following safety instructions relate to any work on components that could be under pressure.

- Switch off the power supply disconnecting device, lock out / tag out the device, verify the absence of any voltage.
- Vent all components and chambers under vacuum to atmospheric pressure.
- Do not open or dismantle any valves.

Working on the drive system

Touching live components can result in electric shocks, burns or death.

Touching the fan wheel or the belt drive while the machine is running can result in serious injury.

- Switch off the power supply disconnecting device, lock out / tag out the device, verify the absence of any voltage.

- Do not open any of the cover panels while the machine is switched on.
- If full protection is only provided when the machine is completely installed, then in all other phases of the machine's life-cycle temporary protective devices (e.g. covers) must be fitted, in order to guarantee that parts of the body cannot reach or be caught/sucked in by the rotary lobes.

Further information Information regarding authorized personnel can be found in chapter 3.4.2.
Information regarding dangers and their avoidance can be found in chapter 3.5.

6.2 Reporting transport damage

1. Check the machine for visible and hidden transport damage.
2. Inform the carrier and the manufacturer in writing of any damage without delay.

6.3 Anchoring the machine

The machine may be anchored to the floor.

The following anchoring elements are shipped with the machine:

Foundation bolts for machines without sound enclosure.

Foundation bolts and angle brackets for machines with sound enclosure.

- Use the anchoring elements to anchor the machine without stress.

Further information Details of the fixing holes are contained in the dimensional drawing in chapter 13.2.

6.4 Connecting the power supply

Precondition The power supply disconnecting device is switched off, lock out and tag out the device, the absence of any voltage has been verified.
The tolerance limits of the power supply are within the tolerance limits of the rated machine voltage.

Option C34, OMEGA FREQUENCY CONTROL (OFC):

The voltage in the intermediate circuit capacitors of the frequency converter is reduced.

1. The power supply must only be connected by authorized installation personnel or authorized certified electricians.
2. Carry out protection measures as stipulated in relevant regulations and in national accident prevention regulations. In addition, observe the regulations of the local electricity supplier.
3. Select supply cable conductor cross-sections and fusing in accordance with local regulations and chapter 2.12.
4. Test the overcurrent protective device to ensure that the time it takes to shut down in response to a fault is within the permitted limit.
5. The user is required to fit the machine with a lockable power supply disconnecting device. This could be, for example, a load disconnect switch with fused input. If a circuit breaker is used it must be suitable for the motor starting characteristics.
6. Check that the control transformer is connected according to the supply voltage.
If not, reconnect the control transformer to suit the power supply voltage.

7. **⚠ DANGER** *Danger of fatal injury from electric shock!*
 - *Switch off and lock out the power supply disconnecting device and verify the absence of voltage.*
8. Connect the machine to the power supply.
9. Properly close openings, cable glands, etc.

Further information The wiring diagram in chapter 13.4 contains further details of the power supply connection.

Connecting the control cabinet

The machine can be operated at full power at the rated voltage with a tolerance of $\pm 5\%$. If the supply voltage deviates from the rated voltage, the control transformer's (component T11) cable bridge should be changed to correspond to the actual main power supply.

1. Select supply cable conductor cross-sections and fusing in accordance with local regulations and chapter 2.12.
2. Connect the control cabinet (note clockwise phase rotation!).

**6.4.1 Option C32
Under frequency control**



If the machine is delivered by KAESER including the frequency converter, the regulation behavior and operating mode of the frequency converter will be preset.

- Adapt and optimize the actual properties to the customer system on-site.
- Comply with the following provisions if you operate machines with a frequency converter:
 - Operate the machine only within its performance limits and under the permitted ambient conditions.
 - The speed change should be approx. 5 Hz per second. This value applies also for the starting ramp from standstill to reaching minimum frequency. Deviating settings, either slower or faster, may be possible after verification by an authorized KAESER SERVICE representative.
 - The frequency converter may be switched to a motor in standstill only, in order to avoid malfunctions.
 - The automatic restart of the machine is **not** preset for safety-relevant reasons.

6.5 Connecting to the vacuum network

Material Torque wrench

Precondition Vacuum network ventilated.



Non-return or check valves must be installed in systems that are to remain under vacuum when the machine is shut down.

- Consult KAESER regarding a suitable check valve and expert installation.
- 1. Create a vacuum connection with compensator or flexible hose line and install with the following torques:

| Connection to customer's pipeline | Torque [lbf-ft] |
|-----------------------------------|-----------------|
| Compensator, suction side | 14.8 |

| Connection to customer's pipeline | Torque [lbf-ft] |
|---|-----------------|
| Compensator at exhaust side with worm drive hose clamps | 3.7 |
| Compensator at exhaust side with hinge pin clamps | 14.8 |

Tab. 29 Compensator torques

2. Support the weight of the pipework and any other connecting components.
3. Discharge exhaust air to the outside by means of suitable pipework.

Further information The dimensional drawing in chapter 13.2 provides information regarding the connection of the pipeline.

6.6 Option H12 Sound enclosure: Removing transport securing devices

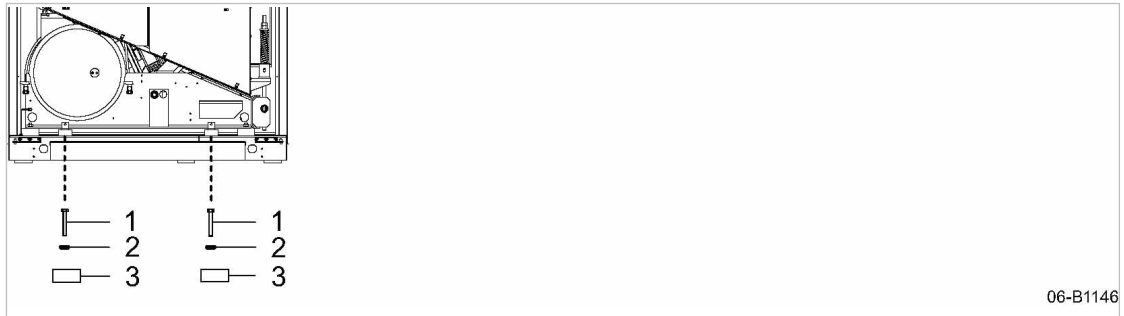

Fig. 17 Removing the transport securing devices

- ① Screw
- ② Washer
- ③ Spacer

Remove the transport securing devices after the machine has been installed.

1. Remove the access panel of the sound enclosure.
2. Remove the transport securing device and store for future transports.

6.7 Option H12 Fitting the cover plate

A base frame cover plate is attached to the belt guard.

Fitting takes place after the machine has been installed.

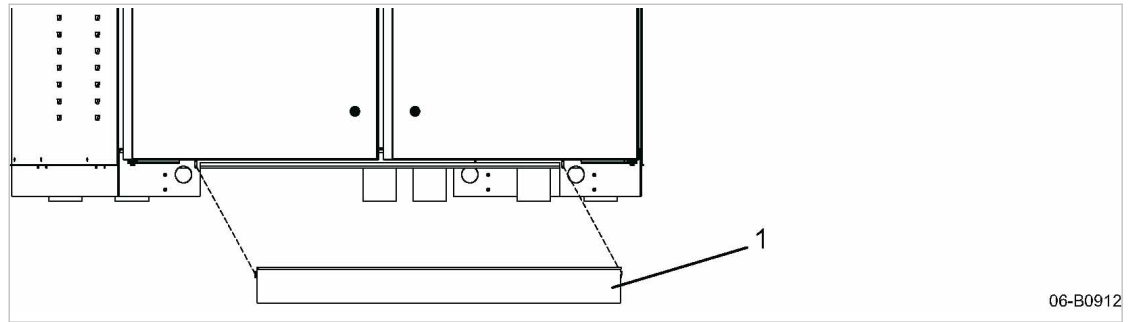

06-B0912

Fig. 18 Fitting the cover plate

① Cover plate

➤ Screw the cover plate to the base frame.

7 Initial Start-up

7.1 Ensuring safety

This chapter provides instructions for safe commissioning of the machine. Warning instructions are provided prior to any potentially dangerous task.



Disregard of warning instructions can result in life-threatening injuries!

Observing safety warnings

Ignoring safety warnings can result in unforeseen dangers.

- Follow the instructions in chapter 3 “Safety and Responsibility”.
- Commissioning tasks may only be carried out by authorized installation personnel!
- Ensure that no personnel are working on the machine.
- Ensure that all cover panels are closed.

Working on live components

Touching live components can result in electric shocks, burns or death.

Dangerous voltages remain in the frequency converter and intermediate circuit capacitors for some time after the power has been disconnected.

When the frequency converter is open, live components are exposed.

- Work on electrical equipment may only be carried out by authorized electricians.
- Switch off the power supply disconnecting device, lock out / tag out the device, verify the absence of any voltage.
- Before starting work on the frequency converter or intermediate circuit capacitors, wait for at least 5 minutes.
- Check that there is no voltage on floating contacts.

Working at the vacuum system

The following safety instructions relate to any work on components that could be under pressure.

- Switch off the power supply disconnecting device, lock out / tag out the device, verify the absence of any voltage.
- Vent all components and chambers under vacuum to atmospheric pressure.
- Do not open or dismantle any valves.

Working on the drive system

Touching live components can result in electric shocks, burns or death.

Touching the fan wheel or the belt drive while the machine is running can result in serious injury.

- Switch off the power supply disconnecting device, lock out / tag out the device, verify the absence of any voltage.

- Do not open any of the cover panels while the machine is switched on.
- If full protection is only provided when the machine is completely installed, then in all other phases of the machine's life-cycle temporary protective devices (e.g. covers) must be fitted, in order to guarantee that parts of the body cannot reach or be caught/sucked in by the rotary lobes.

Further information Information regarding authorized personnel can be found in chapter 3.4.2.
 Information regarding dangers and their avoidance can be found in chapter 3.5.

7.2 Instructions to be observed before commissioning

Incorrect or improper commissioning can cause injury to persons and damage to the machine.

- Commissioning may be carried out only by authorized installation and service personnel who have been trained on this machine.

Special measures for recommissioning after storage/standstill

| Storage period/ standstill longer than | Measure |
|--|---|
| 12 months | <ul style="list-style-type: none"> ➤ Change the lubricating oil. ➤ Re-grease the drive motor bearings if they are not of the permanently-greased type. ➤ Check the condition and tension of the drive belts. ➤ Have the frequency converter smoothing capacitors formed (refreshed) by an authorized KAESER service representative. |
| 36 months | <ul style="list-style-type: none"> ➤ Have the overall technical condition checked by an authorized KAESER service representative. |

Tab. 30 Recommissioning after storage/standstill

7.3 Checking installation and operating conditions

- Check and confirm all the items on the checklist before commissioning the machine.

| To be checked | See chapter | Confirmed? |
|--|-------------|------------|
| ➤ Have all packing materials, tool and transport securing means been removed from the machine? | — | |
| ➤ Are the operators completely familiar with safety regulations? | — | |
| ➤ Have all the installation conditions been fulfilled? | 5 | |
| ➤ Is the machine anchored to the floor? | 6.3 | |
| ➤ Are the tolerance limits of the power supply within the permissible tolerance limits of the rated machine voltage? | — | |
| ➤ Are the power supply cable conductor cross-sections and fuse ratings adequate? | 2.12 | |

7 Initial Start-up

7.4 Re-greasing the motor bearings

| To be checked | See chapter | Confirmed? |
|---|-------------|------------|
| ➤ Is a user-supplied lockable power supply disconnecting device installed? | 6.4 | |
| ➤ Have all electrical connections for control cabinet been checked? | 6.4 | |
| ➤ Suitable non-return valve installed professionally? | 6.5 | |
| ➤ Has the connection to the vacuum network been made with a hose or compensator? | 6.5 | |
| ➤ Has the drive motor's direction of rotation been checked? | 7.7 | |
| ➤ All electrical connections checked for tightness? | — | |
| ➤ Is there adequate lubricating oil in the gear and drive-end of the blower block? (Check oil sight glass) | 10.6 | |
| ➤ Has the drive belt tension been checked? | 10.5 | |
| ➤ Are all access doors closed and latched, and removable panels in place and secured? (Option H12) | 4.1 | |

Tab. 31 Installation conditions check list

7.4 Re-greasing the motor bearings

- The motor bearings of motors with re-greasing facility must be re-greased with bearing grease prior to the initial commissioning of the machine.

Further information Further information on re-greasing motor bearings can be found in chapter 10.12.1.

7.5 Configuring the controller

- Configure the controller as described in the SIGMA CONTROL 2 operating manual.

7.6 Setting the display language

The controller can display message text in several languages.

You can set the language for texts on the display. This setting will be retained even when the machine is switched off.

1. In operating mode, switch to the main menu with the «Enter» key.

2. Press the «UP» or «DOWN» keys until the current language is shown as active line:

| | | |
|---------|------------|--------------------------------|
| 6.1 bar | 80.0 °C | |
| Deutsch | | Current language (active line) |
| ▶1 | xxxxxxxxxx | Submenu |
| ▶2 | xxxxxxxxxx | Submenu |
| ▶3 | xxxxxxxxxx | Submenu |
| ▶4 | xxxxxxxxxx | Submenu |
| ▶5 | xxxxxxxxxx | Submenu |
| ▶6 | xxxxxxxxxx | Submenu |

3. Use the «Enter» key to switch to setting mode.
The language display flashes.
4. Move to the required language with «UP »or «DOWN».
5. Confirm the setting with the «Enter» key.

Result The display texts are now in the selected language.

Further information Detailed information can be found in the SIGMA CONTROL 2 operating manual.

7.7 Checking the direction of rotation for the drive motor

The machine is designed for a clockwise phase sequence.

An arrow showing the correct direction of rotation is indicated on the drive-side of the blower block and on the belt guard.

Should the direction of rotation for the drive motor be wrong, the direction of flow through the machine will be reversed and pressure will rise in the inlet pipe.

A phase sequence relay is installed in the machine control cabinet, which only sends a release signal to the controller when a clockwise direction of rotation is detected.

The controller will report a fault if the direction of rotation is counterclockwise. In this case, exchange phases L1 and L2 of the supply line(s). The fault can then be acknowledged.

Material Phase sequence indicator

NOTICE

Incorrect direction of rotation!

This may result in damage to the machine from intake of foreign articles or excessive vacuum.

➤ *Ensure the correct direction of rotation.*

1. Remove the filter maintenance cover from the inlet silencer or inlet filter and/or remove the non-return valve on the inlet side.
2. Verify the direction of rotation using a phase sequence indicator on the machine supply lines.
3. If the direction of rotation is incorrect, exchange phases L1 and L2 of the supply lines.



If you do not have access to a phase sequence indicator:

➤ Arrange for the phase sequence to be checked by an authorized KAESER service representative.

7.8 Option C33**START CONTROL (STC): Setting the overload protection cut-out**

The electrical diagram 13.4 gives the location of the overload protection cut-out.

With star-delta starting, the phase current is fed via the overload protection relay. This phase current is 0.58-times the rated drive motor current.

To prevent the overload relay being triggered by voltage fluctuations, temperature influences or component tolerances, the setting can be higher than the arithmetical phase current.

- Check the overload protection relay setting.



The overload protection relay shuts the machine down despite being correctly set?

- Contact an authorized KAESER service representative.

7.9 Starting the machine for the first time

Precondition No personnel are working on the machine.
The control cabinet's door is closed and locked.
All maintenance doors and panels are in place and secured.

1. Allow the machine to cool to ambient temperature before switching on for the first time to avoid the build up of condensation.
2. Switch on the power supply disconnecting device.
After the controller has carried out a self-test, the green *Control voltage* LED is lit continuously.
3. If required:
Change the display language as described in chapter 7.6.
4. Press the «ON» key.
The green *IDLE* LED is lit continuously.
The drive motor runs up.



- Watch for any faults occurring in the first hours of operation.
- After the first 50 operating hours, check all electrical connections and tighten where necessary.

8 Operation

8.1 Switching on and off

Always switch the machine on with the «ON» key and off with the «OFF» key.
A power supply disconnecting device has been installed by the user.

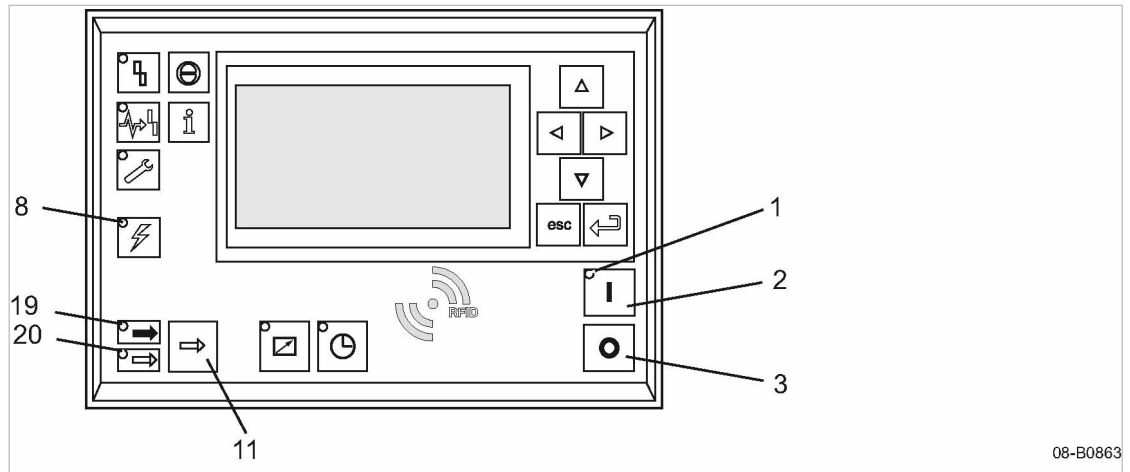

Fig. 19 Switching the machine on and off

- | | |
|--|--------------------------|
| ① <i>ON</i> LED | ⑪ «LOAD/IDLE» toggle key |
| ② «ON» key | ⑲ <i>LOAD</i> LED |
| ③ «OFF» key | ⑳ <i>IDLE</i> LED |
| ⑧ <i>Voltage applied to controller</i> LED | |

8.1.1 Switching on

Precondition No personnel are working on the machine.
No personnel inside the machine.
All maintenance doors and removable panels are in place and secured.

1. Switch on the power supply disconnecting device.
The *Voltage applied to controller*LED lights green.
2. Press the «ON» key.
The *ON*LED lights green.

Starting frequency

| Characteristic, option | Maximum frequency of motor starts per hour |
|---------------------------------------|--|
| C33, START CONTROL (STC) | ■ 6 times |
| C34, OMEGA FREQUENCY CONTROL (OFC) | ■ Any |

Tab. 32 Starting frequency

- Adhere to maximum frequency of motor starts per hour.

Automatic restart

If a power failure occurs, the machine is **not** prevented from re-starting automatically when power is resumed.

It can re-start automatically as soon as power is restored.

- Note the instructions in the User Manual supplied with SIGMA CONTROL 2 for activating and deactivating this function.

8.1.2 Switching off

1. Press the «OFF» key.

When the machine switches to IDLE (as per configuration), and during the fan run-on time, the *ON*LED flashes. The *ON*LED extinguishes as soon as the automatic shut-off action is completed.

2. Switch off and lock out the power supply disconnecting device.

Result The *Voltage applied to controller* LED extinguishes. The machine is switched off and disconnected from the power supply.



In rare cases, you may want to shut down the machine immediately and cannot wait until the automatic shut-down process is finished.

- Press «OFF» once again.

8.2 Switching off and on in an emergency

The EMERGENCY STOP push-button is located to the right of the control panel.

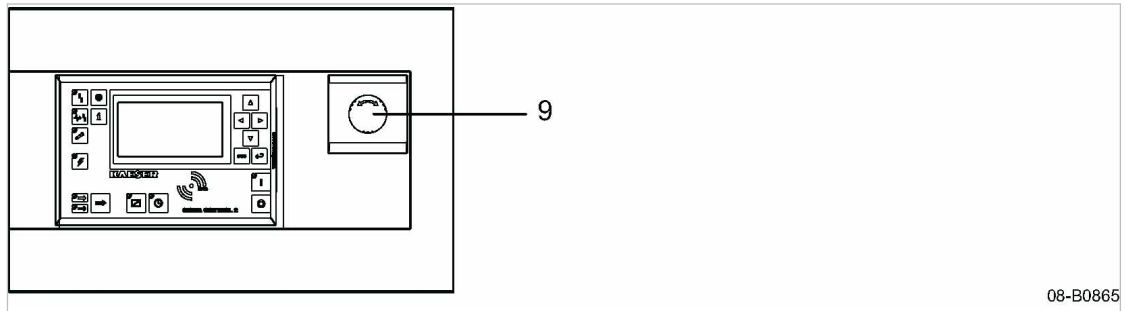

08-B0865

Fig. 20 Switching off in an emergency

- ⑨ EMERGENCY-STOP push button

Switching off

- Press the EMERGENCY STOP push button.

Result The EMERGENCY STOP push button remains latched after actuation. The compressor's pressure system is vented and the machine is prevented from automatically re-starting.

Switching on

Precondition The fault has been rectified.

1. Turn the EMERGENCY STOP push button in the direction of the arrow to unlatch it.
2. Acknowledge any existing alarm messages.

Result The machine can now be started again.

8.3 Switching on and off from a remote control center

Precondition A link to the remote control center exists.

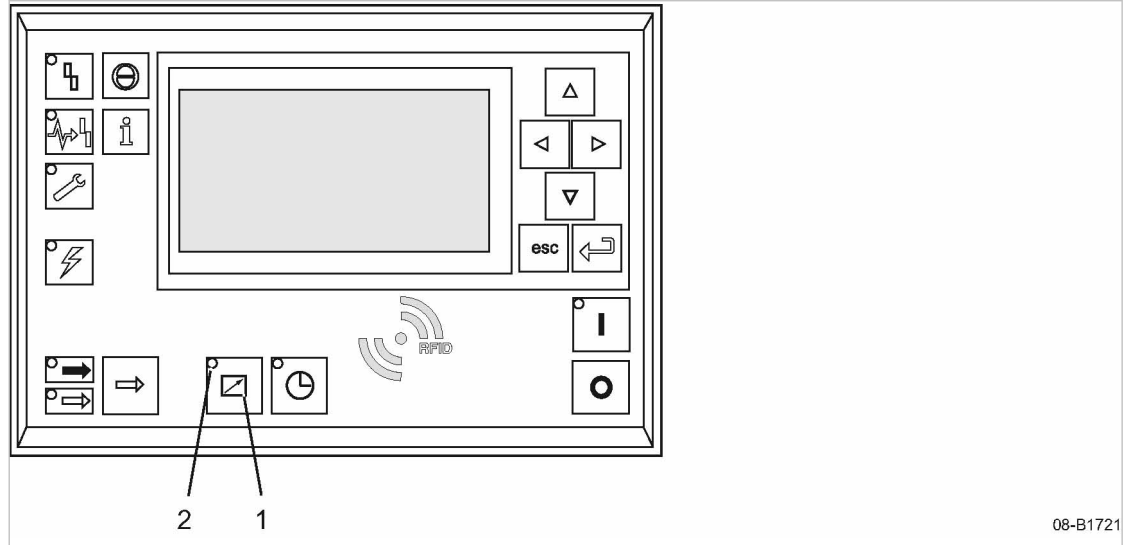

Fig. 21 Switching on and off from a remote control center

- ① «Remote control» key
- ② *Remote control* LED

1. Attach an easily seen notice to the machine that warns of remote operation.

⚠ WARNING

Remote control: Risk of injury caused by unexpected starting!

- Make sure that the power supply disconnecting device is switched off before commencing any work on the machine.

Tab. 33 Machine identification

2. Label the starting device in the remote control center as follows:

⚠ WARNING

Remote control: Risk of injury caused by unexpected starting!

- Before starting, make sure that no one is working on the machine and that it can be safely started.

Tab. 34 Remote control identification

3. Press the «Remote control» key.

Result The *Remote control* LED lights. The machine can be remotely controlled.

8.4 Switching on and off with the clock (timer)

Precondition The clock is programmed.

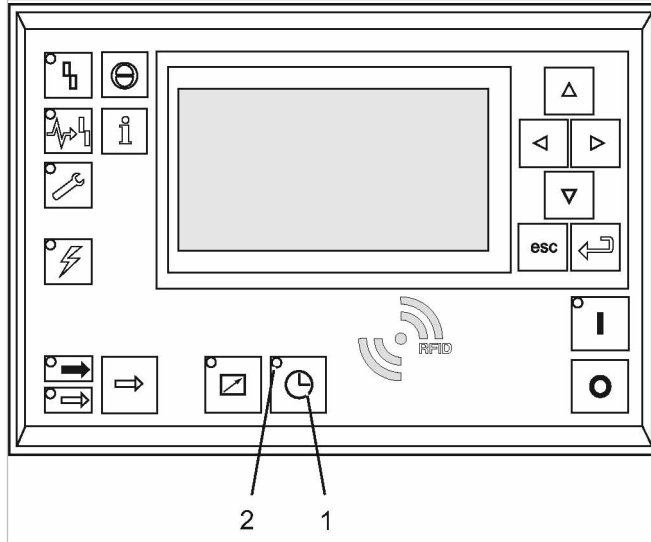

Fig. 22 Switching on and off with the clock (timer)

- ① «Timer control» key
- ② *Timer control* LED

1. Attach an easily seen notice warning of time-controlled operation:

⚠ WARNING

Time control: Risk of injury caused by unexpected starting!

- Make sure that the power supply disconnecting device is switched off before commencing any work on the machine.

Tab. 35 Machine identification

2. Press «Timer control».

Result The *Timer control*/LED lights. The machine is switched on and off by the clock (timer).

8.5 Option H12 Checking the ventilator fan function (sound enclosure)

NOTICE

Overheating inside the sound enclosure!

A standstill of the ventilator can result in a breakdown of the blower block or other components.

- *If the ventilator stops, immediately provide an alternative flow of cooling air through the sound enclosure.*

- Check that air is actually being blown out of the enclosure cooling air outlet, e.g. by holding a sheet of paper in front of the outlet.

Further information KAESER SERVICE will advise on suitable measures.

8.6 Interpreting operation messages

The controller will automatically display operation messages informing you about the current operational state of the machine.

Operating messages are identified with the letter B.

Further information Detailed information can be found in the SIGMA CONTROL 2 operating manual.

8.7 Acknowledging alarm and warning messages

Messages are displayed on the "new value" principle:

- Message coming: LED flashes
- Message acknowledged: LED illuminates
- Message going: LED off

or

- Message coming: LED flashes
- Message going: LED flashes
- Message acknowledged: LED off

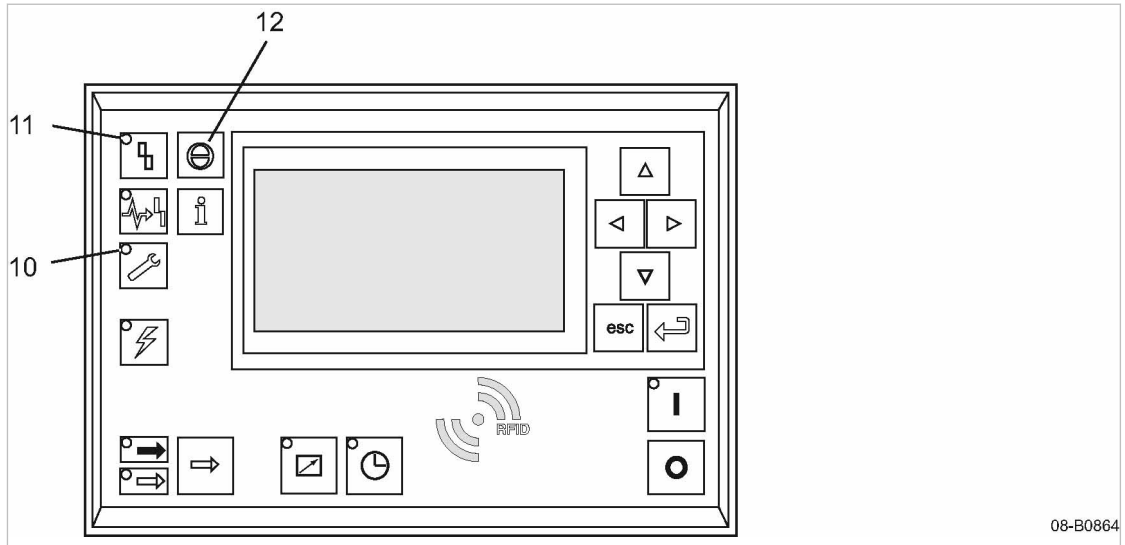

Fig. 23 Acknowledging messages

- 10 *Warning* LED (yellow)
- 11 *Alarm* LED (red)
- 12 «Acknowledge» key

Alarm message

An alarm shuts the machine down automatically. The red *Alarm* LED flashes. The system displays the appropriate message.

Precondition The fault has been rectified.

- Acknowledge the message with the «Acknowledge» key. The *Alarm* LED extinguishes. The machine is again ready for operation.



If the machine was switched off with the EMERGENCY STOP button:

- Unlatch the EMERGENCY STOP button (turn in direction of the arrow) before acknowledging the alarm message.

Further information Please refer to the SIGMA CONTROL 2 operating manual for a list of possible fault messages during operation.

Warning message

If maintenance work is to be carried out or if the warning is displayed before an alarm, the yellow *Warning* LED flashes. The system displays the appropriate message.

Precondition The danger of an alarm is passed, maintenance has been carried out.

- Acknowledge the message with the «Acknowledge» key. The *Warning* LED extinguishes.

Further information Please refer to the SIGMA CONTROL 2 operating manual for a list of possible warning messages during operation.

9 Fault Recognition and Rectification

9.1 Basic instructions

Fault messages are classified in various categories:

- Warning:
 - Warning messages *W*
- Fault (with indication):
 - Alarm messages *S*
 - System messages *Y*
 - Diagnostic messages *D*
- Other faults (without indication): See chapter 9.2

The messages valid for your machine are dependent on how the individual machine is equipped.

1. Do not attempt fault rectification measures other than those given in this manual!
2. In all other cases:
Have the fault rectified by an authorized KAESER SERVICE representative.

Further information See the operating manual of SIGMA CONTROL 2 for details regarding the various messages.

9.2 Other faults

| Alarm | Possible cause | Remedy |
|--|---|---|
| Unusual noise when running. | Too much backlash in the timing gears. | Contact KAESER Service. |
| | Too much clearance in the rotor bearings. | Contact KAESER Service. |
| | Rotors not synchronized. | Maintain the pressure differential and speed shown in the specification. Contact KAESER Service. |
| Blower block runs too hot. | Pressure differential too great. | Check and correct pressure differential. |
| | Clogged inlet filter reducing air intake volume. | Clean the inlet filter. |
| | Rotor clearance too large. | Contact KAESER Service. |
| | Leakage due to incorrect installation of pressure-bearing components. | Contact KAESER Service. |
| Oil leaks from the gas drain. | Lubricating oil level too high. | Drain off lubricating oil until the correct level is reached. |
| Oil leaking from around the drive shaft. | Shaft seal defective. | Contact KAESER Service. |
| Low intake flow volume. | Rotor clearance too large because of wear. | Contact KAESER Service. |
| | Intake resistance too high. | Clean the inlet filter. |

| Alarm | Possible cause | Remedy |
|--------------------------------------|---|--|
| Black film on the oil sight glasses. | Oil not changed at the correct interval. | Change the lubricating oil. Clean or renew the sight glass. |
| | Insufficient lubricating oil. | Change the lubricating oil. Clean or replace the sight glass. |
| | Oil overheated. | Contact KAESER Service. |
| | Block overloaded. | Contact KAESER Service. |
| Water in the oil. | Condensate build-up by prolonged storage and high humidity. | Change the lubricating oil. |
| Safety relief valve activates. | Inadmissible operating state, operating pressure too high. | Bring the machine to a permissible operational state or shut down. |

Tab. 36 Other faults and remedies

9.3 Option H12 Sound enclosure faults

| Alarm | Possible cause | Remedy |
|---|---|--|
| Overheating inside the sound enclosure! | Fan defective or turning in the wrong direction. | Check connection. Contact an authorized KAESER service representative. |
| | Flow of cooling air blocked. | Check and clean cooling air apertures. Check the cooling air inlet temperature. |
| | Drive motor overloaded. | Check operating conditions. |
| | Leakage due to incorrect installation of pressure-bearing components. | Contact an authorized KAESER service representative. |

Tab. 37 Faults and remedies (option H12)

10 Maintenance

10.1 Ensuring safety

Follow the safety instructions below to ensure safe maintenance of the machine. Warning instructions are provided prior to any potentially dangerous task.



Disregard of warning instructions can result in life-threatening injuries!

Observing safety warnings

Ignoring safety warning can result in unforeseen dangers.

- Follow the instructions in chapter 3 “Safety and Responsibility”.
- Allow maintenance work to be performed by authorized personnel only!
- Ensure that no personnel are working on the machine.
- Ensure that all cover panels are closed.

Working on live components

Touching live components can result in electric shocks, burns or death.

Dangerous voltages remain in the frequency converter and intermediate circuit capacitors for some time after the power has been disconnected.

When the frequency converter is open, live components are exposed.

- Work on electrical equipment may only be carried out by authorized electricians.
- Switch off the power supply disconnecting device, lock out / tag out the device, verify the absence of any voltage.
- Before starting work on the frequency converter or intermediate circuit capacitors, wait for at least 5 minutes.
- Check that there is no voltage on floating contacts.

Working at the vacuum system

The following safety instructions relate to any work on components that could be under pressure.

- Switch off the power supply disconnecting device, lock out / tag out the device, verify the absence of any voltage.
- Vent all components and chambers under vacuum to atmospheric pressure.
- Do not open or dismantle any valves.

Working on the drive system

Touching live components can result in electric shocks, burns or death.

Touching the fan wheel or the belt drive while the machine is running can result in serious injury.

- Switch off the power supply disconnecting device, lock out / tag out the device, verify the absence of any voltage.

- Do not open any of the cover panels while the machine is switched on.
- If full protection is only provided when the machine is completely installed, then in all other phases of the machine's life-cycle temporary protective devices (e.g. covers) must be fitted, in order to guarantee that parts of the body cannot reach or be caught/sucked in by the rotary lobes.

Further information Information regarding authorized personnel can be found in chapter 3.4.2.
Information regarding dangers and their avoidance can be found in chapter 3.5.

10.2 Maintenance schedule

10.2.1 Logging maintenance work



- The maintenance intervals given are those recommended for average operating conditions.
- Maintenance tasks should be carried out more frequently where operating conditions are unfavorable (e.g. dusty atmosphere) or when the equipment is in constant use.
 - Adjust the maintenance intervals with regard to local installation and operating conditions.
- Keep a log of all maintenance and service work.
This enables the frequency of individual maintenance tasks and deviations from our recommendations to be determined.

Further information A prepared list is provided in chapter 10.15.

10.2.2 Resetting maintenance interval counters

Depending on the way a machine is equipped, sensors and/or maintenance interval counters monitor the operational state of important functional devices. Required maintenance work is shown on the SIGMA CONTROL 2.

Precondition Maintenance performed and,
Maintenance message acknowledged.

- Reset the maintenance interval counter as described in the SIGMA CONTROL 2 operating manual.

10.2.3 Regular maintenance tasks

The table below lists the required maintenance tasks.



- If operating conditions are unfavorable (e.g. dusty ambient) or if the equipment is in constant use, maintenance tasks must be carried out more frequently (shorter intervals).

- Carry out maintenance tasks in a timely manner, taking the ambient and operating conditions into consideration:

| Interval | Maintenance task | See chapter |
|---|--|-------------|
| At least 24 hours after initial commissioning | Check drive belt tension. | 10.5 |
| At least 50 hours after initial commissioning | Check that all electrical connections are secure and tighten if necessary. | – |
| Weekly | Control cabinet: Check the filter mat. | 10.3 |
| 500 hours after initial commissioning* | Change the lubricating oil. | 10.8 |
| Up to 500 h Or monthly | Check the oil level. | 10.6 |
| | Check drive belt tension. | 10.5 |
| | Check the air filter. | 10.9 |
| | Control cabinet: Clean the filter mat. | 10.3 |
| Up to 1000 h | Clean the machine. | 10.11 |
| Up to 2000 h At least once a year | Drive motor bearings with re-greasing facility: Re-grease the motor bearings. | 10.12.1 |
| Up to 3000 h At least once a year | Change the FGB 220 lubricating oil. | 10.8 |
| Up to 3000 h, At least once a year | Change the air filter. | 10.9 |
| | Control cabinet: Replace the filter mat. | 10.3 |
| Annually | Check the safety relief valve. | 10.13 |
| | Check the EMERGENCY STOP push button. | 10.14 |
| | Check that all electrical connections are secure and tighten if necessary. | – |
| Up to 6000 h, At least every 2 years | Change the SB 220 lubricating oil. | 10.8 |
| Up to 12000 h, At least every 4 years | Replace the drive belt. | 10.5 |

h = operating hours

* Not applicable in the case of initial commissioning by an authorized KAESER service representative.

Tab. 38 Regular maintenance tasks

10.2.4 Regular service tasks

The table below lists necessary service tasks.

- Only an authorized KAESER service representative should carry out service work.

- Have maintenance tasks carried out in a timely manner, taking the ambient and operating conditions into account:

| Interval | Service task |
|--|--|
| Up to 12000 h, At least every 4 years | Permanently greased drive motor bearings: Replace the motor bearings. |
| Up to 36000 h | Blower block Replace the radial shaft sealing ring. |
| | Drive motor bearings with re-greasing facility: Replace the motor bearings. |
| | Fan frequency converter: Replace the fan. |
| | Fan control cabinet: Replace the fan. |
| | Sound enclosure: Replace the fan. |
| Up to 36000 h, At least every 8 years | (Option G1) Maintain the check valve. |
| | Replace the compensators |
| At least every 20 years | Replace safety-relevant components of the safety functions. |

h = operating hours

Tab. 39 Regular service tasks

10.3 Cleaning or replacing the control cabinet filter mats

Filter mats protect the control cabinet from ingress of dirt. If the filter mats are clogged, adequate cooling of the components is no longer ensured. In such a case, clean or replace the filter mats.

Material Warm water and household detergent
Spare parts (as required)

Precondition The power supply disconnecting device is switched off,
the device is locked off,
the absence of any voltage has been verified.



Fig. 24 Control cabinet ventilation grill

- ① Ventilation grill
- ② Filter mat

1. Carefully remove the ventilation grill and take out the filter mat.
2. Beat the mat or use a vacuum cleaner to remove loose dirt. If necessary, wash with lukewarm water and household detergent.
3. Replace the filter mat if cleaning is not possible or if the change interval has expired.
4. Lay the filter mat in the frame and latch in the ventilation grill.

10.4 Option H12 Sound enclosure

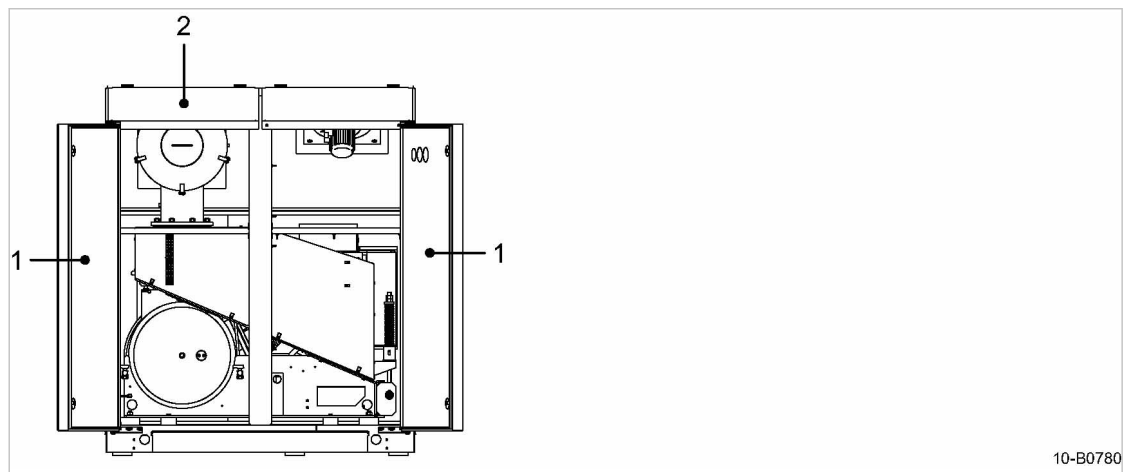

Fig. 25 Sound enclosure

- ① Access door
- ② Cover with two flaps

- Open maintenance door ① for maintenance tasks.
- If required, open the flap(s) ②
Latches are released by a key supplied with the machine.



FB 441 C vac and FB 621 C vac: Crushing hazard due to potential risk of flap(s) falling back down.

- Fold the flap(s) ② back completely to safeguard against unintentional folding back down.

10.5 Drive belt maintenance

Material Spare parts (if required)

Precondition The power supply disconnecting device is switched off, lock out and tag out the device, the absence of any voltage has been verified.
The machine has cooled down.

⚠ WARNING

Touching the moving drive belt may result in severe bruising or even loss of limb or extremities.

- *Switch off and lock out/tag out the power supply disconnecting device and verify the absence of voltage.*

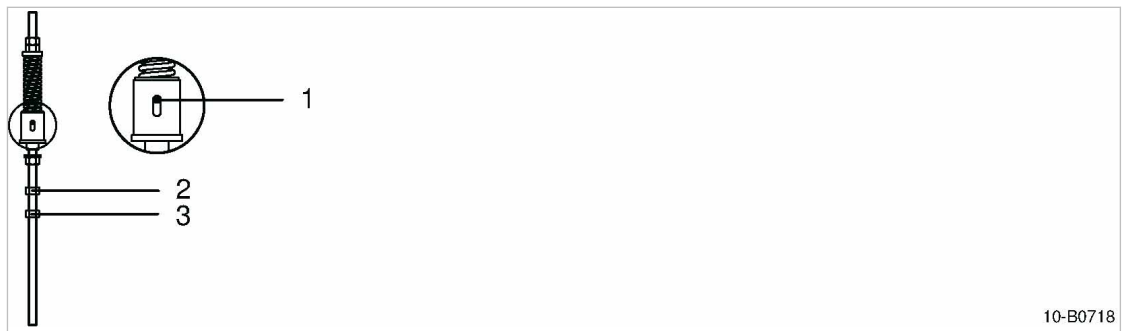

Fig. 26 Drive belt maintenance

- ① Marker pin (shown as: belt tensioning required)
- ② Locking nut
- ③ Adjusting nut

Checking belt tension and adjustment

The tensioning device uses spring force to apply correct tension to the belt.

Adjust the tension before the marker pin reaches the **top** end of the elongated hole.

1. Loosen the locking nut ②.
2. Use the adjusting nut ③ to adjust spring tension until the marker pin reaches the lower end of the elongated hole.
3. Tighten the locking nut ②.

Visually check for damages.

1. **⚠ CAUTION** *Danger of pinching between belt and pulley!*
➤ *Work carefully.*
2. Turn the pulley by hand so that the entire belt can be inspected for damage.
3. In case of damage: Replace the drive belt immediately.



When individual belts fail in multiple-groove drives, all belts must be replaced.

Changing the belt.

1. Remove the belt guard.
2. Loosen the locking nut ②.
3. Turn the adjusting nut ③ to loosen the tension on the belts until they can be removed from the pulley.
4. Install the new set of belts and use the adjusting nut ③ to adjust the tension until the marker pin reaches the lower end of the elongated hole.
5. Tighten the locking nut ②.
6. Replace the belt guard.
7. Check the tension after the new belt has been in operation for 50 hours.

10.6 Checking the oil level

The true oil level can be seen in the oil sight glass only when the machine is stopped.



The gear-end and drive-end oil chambers are not connected.

⚠ WARNING

Danger of burns from hot components!

- *Wear long-sleeved clothing and protective gloves.*

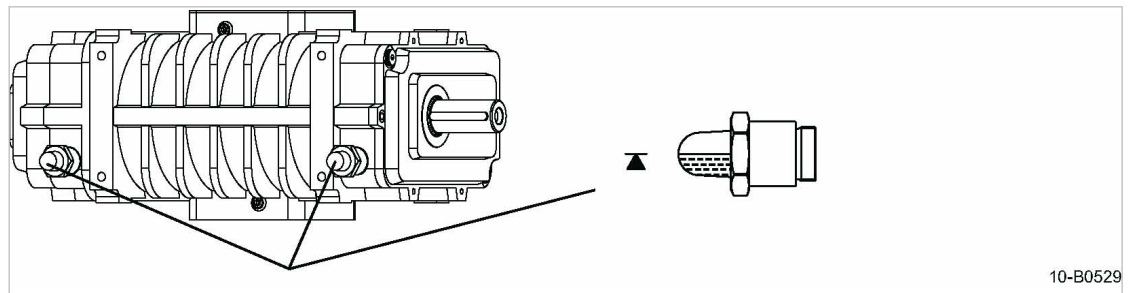

Fig. 27 Checking the oil level

1. Check the oil level in the sight glasses on both ends of the block.
2. Replenish as soon as the level falls 0.3 in. below the center of the sight glass.

10.7 Replenishing lubricating oil

Labels giving the oil type for replenishing can be found on the blower block and belt guard.



Prior to any work requiring an opening of the vacuum system, the machine must be fully vented to atmospheric pressure.

Precondition The power supply disconnecting device is switched off
The disconnecting device is locked in the off position.
The oil level has settled.

⚠ WARNING

Danger of burns from hot components and oil!

- *Wear long-sleeved clothing and protective gloves.*

NOTICE

Unsuitable oil can damage the block.

- *Never mix different types of oil.*
- *Never top off with a different type of oil than that already used in the blower block.*

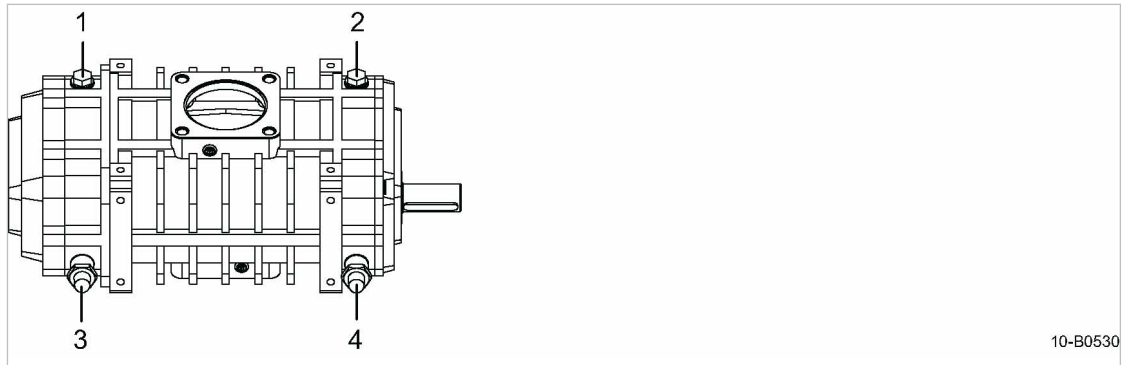

10-B0530

Fig. 28 Replenishing lubricating oil

- | | |
|---|---|
| <p>① Plug (oil filling port, control end)</p> <p>② Plug (oil filling port, drive end)</p> | <p>③ Control-end oil sight glass</p> <p>④ Drive-end oil sight glass</p> |
|---|---|

1. Slowly remove the plug ① and/or ②.
2. Top off until the level is at the marking on the sight glass ③ and/or ④.
3. Screw in the plugs.
4. Visually check for leaks.

10.8 Changing the oil



Prior to any work requiring an opening of the vacuum system, the machine must be fully vented to atmospheric pressure.

The oil should be changed with the block temperature at 130°F to ensure the oil flows freely.

Drain the oil thoroughly from the blower block:

- Control end
- Drive end

Material Lubricating oil
Oil receptacle

Precondition The power supply disconnecting device is switched off,
The device is locked off,
A check has been made that no voltage is present.

⚠ WARNING

Danger of burns from hot components and oil!

➤ *Wear long-sleeved clothing and protective gloves.*

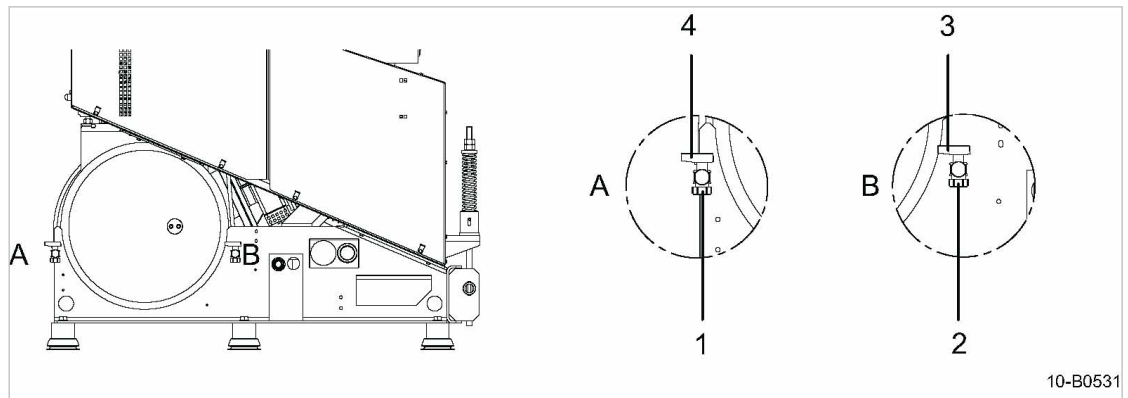

Fig. 29 Changing the oil

- Ⓐ Drive end
- Ⓑ Control end
- ① Cap

- ② Cap
- ③ Oil drain tap
- ④ Oil drain tap

Draining the oil

1. Prepare an oil receptacle.
2. Open the filler plugs at the oil inlet of the blower block ① and ② (Fig. 28).
3. Take off the caps ① and ② and open the oil drain taps ③ and ④.
4. Drain the lubricating oil.



Dispose of the old oil in accordance with local environmental protection regulations.

Filling with fresh oil

1. Fill with fresh oil.
2. Allow the oil drain taps to remain open until fresh oil begins to run out (bleeding the oil drain lines).
3. Close the oil drain taps ③ and ④.
4. Check the oil level in both sight glasses (Fig. 28) and top off as necessary.
5. Screw on the caps ① and ②.
6. Replace and tighten the plugs of the oil inlets at the blower block.
7. Visually check for leaks.

10.9 Air filter maintenance

The air filter protects the vacuum system contained in the scope of delivery from ingress of dirt.

NOTICE

*Machine damage caused by unsuitable air filter!
Dirt can enter the vacuum system and cause damage to the machine.*

➤ Use only genuine KAESER replacement air filters.



The air filter cannot be cleaned.

10.10 Air filter maintenance



Prior to any work requiring an opening of the vacuum system, the machine must be fully vented to atmospheric pressure.

Material Spare parts

Precondition The power supply disconnecting device is switched off, the device is locked off, the absence of any voltage has been verified, the machine has cooled down.

⚠ WARNING

Danger of burns from hot components!

➤ Wear long-sleeved clothing and gloves.

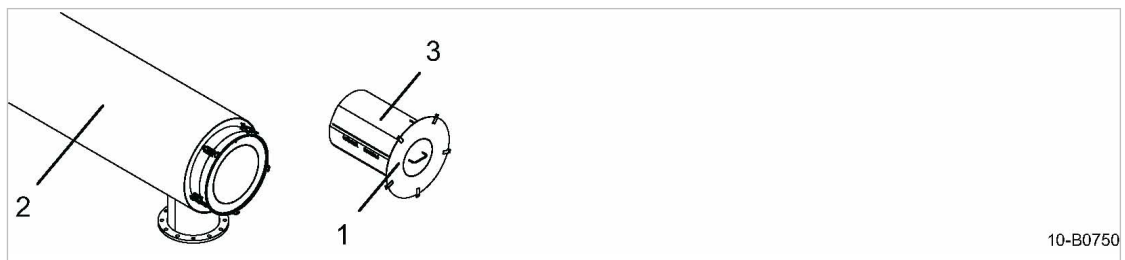

Fig. 30 Changing the air filter

- ① Cover
- ② Inlet silencer
- ③ Air filter

1. Open the snap fastener on the inlet silencer cover.
2. Take off the cover ①.
3. Loosen the Velcro strip and remove the air filter ③.
4. Clean all parts and sealing surfaces.
5. Place the new filter around the perforated inlet port and secure with the Velcro strip.
6. Attach the cover to the inlet silencer.

10.11 Machine cleaning

Regularly clean the machine. This ensures reliable cooling of the machine. The frequency is mainly dependent on local operating conditions.



Clogged machines are indicative of unfavorable ambient conditions. Such ambient conditions clog the cooling air ducts in the machine's interior and the motors resulting in increased wear and tear.

Material Brush and/or compressed air
Protective gloves
Face mask and safety goggles (if required)
Vacuum cleaner

Precondition The power supply disconnecting device is switched off,
the device is locked off,
the absence of any voltage has been verified.
The machine has cooled down.

1. Open the sound enclosure (Option H12).
Dismantle panels in order to clean the cooling air ducts of the drive motor.
2. Dry brush the machine or blow off with compressed air.
3. Vacuum off dirt.
4. Close sound enclosure (Option H12).
Replace and lock panels.



The machine cannot be cleaned?

- Have severe clogging removed by an authorized KAESER service representative.

10.12 Motor maintenance

Motor maintenance depends on the type of motor.

Material Grease gun with bearing grease UNIREX N3
Cleaning cloth

10.12.1 Drive motor bearings with re-greasing facility



Use only the high temperature grease UNIREX N3 for the motor bearings. Damage to bearings caused by the use of other brands of grease is excluded from the warranty.

The required quantity of grease is stated on the motor maintenance plate.

Precondition The motor is running.

1. **⚠ WARNING** *Noise during machine operation (without sound enclosure) or noise due to opened service access of the sound enclosure (Option H12)! Hearing may be damaged.*
 - *Always wear ear protection.*
2. **⚠ WARNING** *Danger of burns from hot components!*
 - *Wear long-sleeved garments and gloves.*
 - *Work with caution.*

3. **NOTICE** *Drive motor damage due to incorrect re-greasing!*
If the motor is switched off, the new bearing grease is distributed incorrectly and pressed unused into the old grease tank.
 - Re-grease the bearings only with the motor running.
4. The motor bearings must be replaced in the course of regular maintenance by an authorized KAESER service representative.

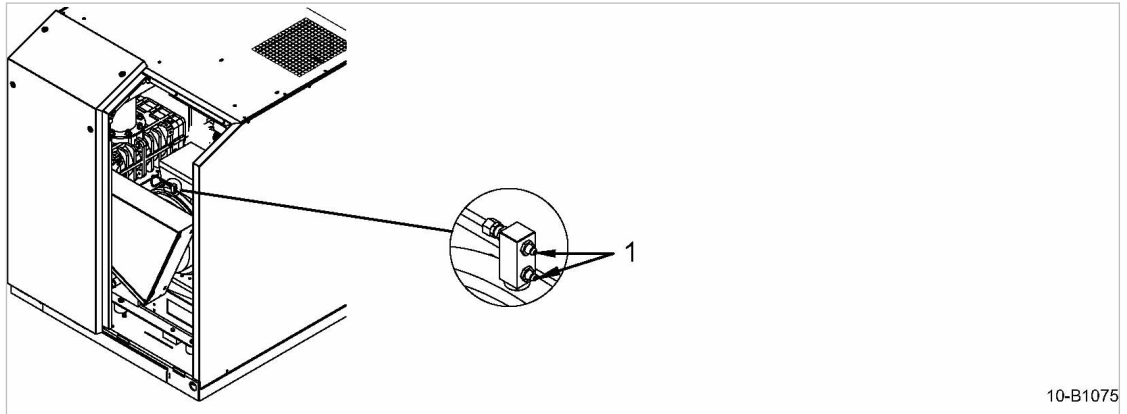

10-B1075

Fig. 31 Maintenance of a drive motor with re-greasing facility

① Grease fittings

1. Open the right-side service panel of the sound enclosure.
2. Clean the grease fittings ① with a cloth before greasing.
3. Grease both bearings with a grease gun.
4. Close the service panel, close the latch.

Further information The re-greasing interval and required quantity of grease are provided in chapter 2.4.
For further information regarding the motor, please consult the motor manual.

10.12.2 Permanently greased drive motor bearings

The motor bearings are permanently lubricated. Re-greasing is not necessary.

- The motor bearings must be replaced in the course of regular maintenance by an authorized KAESER service representative.

Further information For further information regarding the motor, please consult the motor manual.

10.12.3 Fan motor

The motor bearings are permanently lubricated. Re-greasing is not necessary.

- The fan must be replaced in the course of regular maintenance by an authorized KAESER service representative.

10.13 Testing the safety relief valve

Precondition The machine is switched off.
The machine is fully vented to atmosphere.

- Check the safety relief valve for free movement.

The valve opens as soon as maximum working pressure is exceeded.

- Never operate the machine without a correctly functioning safety relief valve.
- Do **not** adjust the safety relief valve.
- Replace a defective safety relief valve.

10.14 Testing the EMERGENCY STOP push button

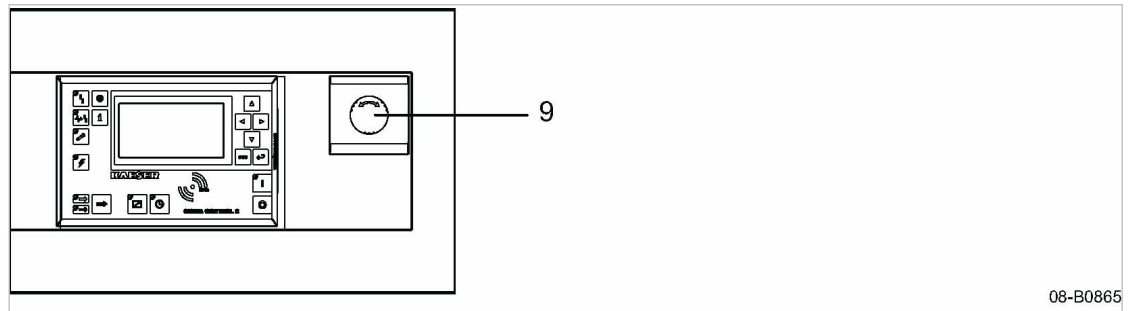

Fig. 32 Testing the EMERGENCY STOP push button

⑨ EMERGENCY STOP push button

Precondition The drive motor is running.

1. Press the EMERGENCY STOP push button.

The drive motor stops, the pressure system is vented and the machine is prevented from automatic restarting.



The drive motor does not stop?

The safety function of the EMERGENCY STOP push button is no longer ensured.

- Immediately shut down the machine and contact an authorized KAESER service representative.

2. Turn the EMERGENCY STOP push button in the direction of the arrow to unlatch it.
3. Acknowledge the fault message.

11 Spares, Operating Materials, Service

11.1 Note the nameplate

The nameplate contains all information to identify your machine. This information is essential to us in order to provide you with optimal service.

- Please give the information from the nameplate with every inquiry and order for spares.

11.2 Ordering spares and operating fluids/materials

KAESER consumable parts and operating fluids/materials operating materials are original KAESER products. They are specifically selected for use in KAESER machines.

⚠ WARNING

There is risk of personal injury or damage to the machine resulting from the use of unsuitable spare parts or operating fluids/materials.

Non-Kaeser parts and operating fluids/materials may be unsuitable or of poor quality and can damage the machine or impair its proper function.

Damage to the machine can also result in personal injury.

- *Use only original KAESER parts and operating fluids/materials.*
- *Have authorized KAESER SERVICE representative carry out regular repair and maintenance.*

Machine

| Name | Number |
|------------------------------|--------|
| Drive belt | 1800 |
| Filter mat (control cabinet) | 1150 |
| Air filter | 1250 |
| Lubricating oil | 1600 |

Tab. 41 Consumable parts

11.3 Replacement parts for service and repair

Use these spare parts lists to plan your material requirement according to operating conditions and to order the required spare parts.



- Make sure that any service or repair tasks not described in this manual are carried out by an authorized KAESER service representative.

11.3.1 Option C33, START CONTROL (STC)

| Legend | | KAESER |
|-----------|------------------------------|---------------|
| FBC.2 vac | | SEL-3905_01 E |
| Item | Description | Option |
| 1250 | Air filter insert | |
| 1252 | Inlet silencer gasket | |
| 1600 | OMEGA FLUID | |
| 1800 | Drive belt | |
| 2410 | Check valve | X |
| 2440 | Vacuum limiting valve | |
| 4050 | OMEGA blower block | |
| 4200 | Airend pulley | |
| 4205 | Tapered bushing, airend | |
| 4450 | Drive motor | |
| 4550 | Drive motor pulley | |
| 4555 | Tapered bushing, drive motor | |
| 4700 | Fan unit | X |
| 7790 | Compensator, air inlet | X |
| 7800 | Compensator, air outlet | X |

11.3.2 Option C34, OMEGA FREQUENCY CONTROL (OFC)

Service-Kit
(Option)

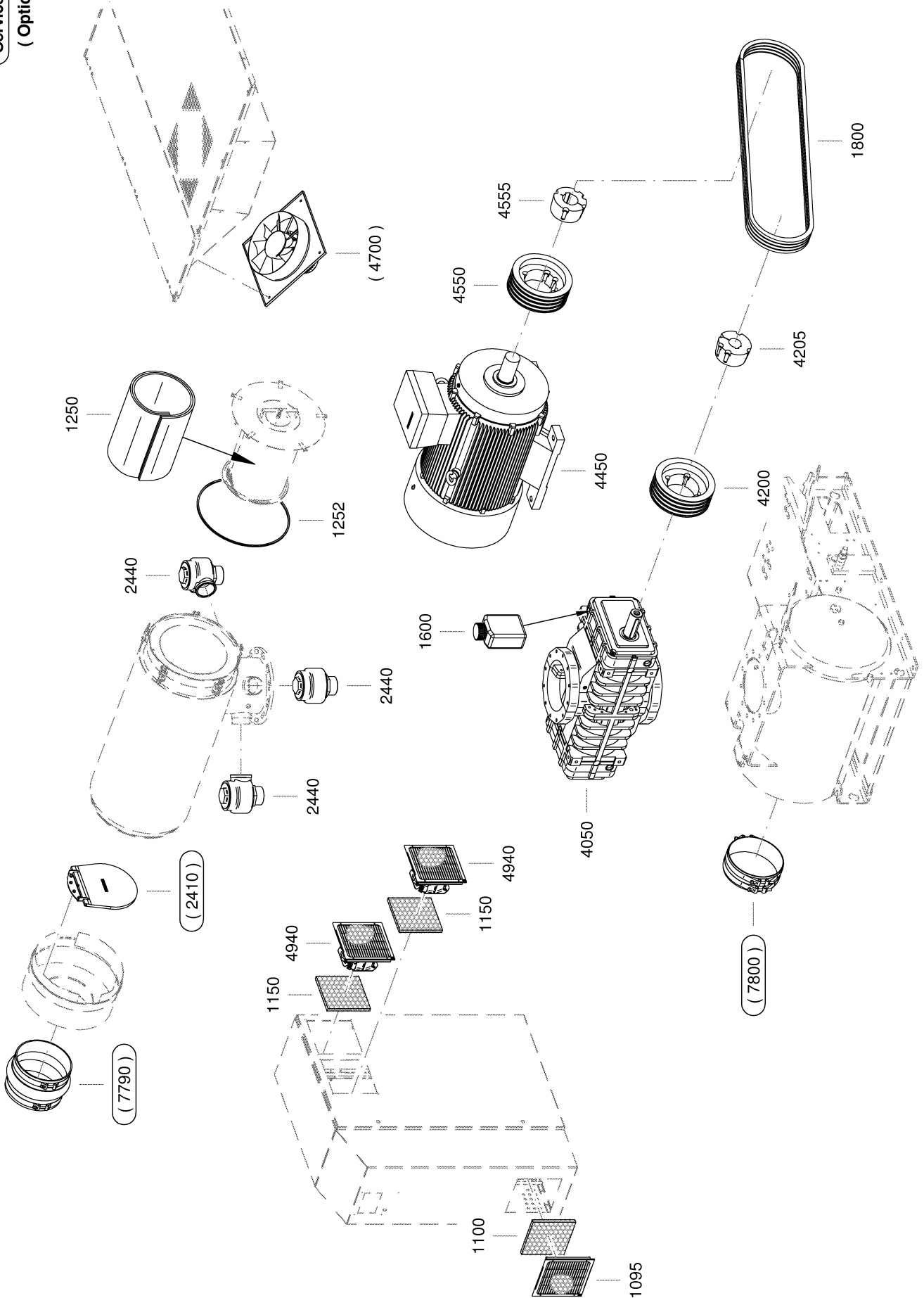

| Legend | | KAESER |
|---------------|-------------------------------|---------------|
| FBC.2 OFC vac | | SEL-3935_01 E |
| Item | Description | Option |
| 1095 | Control cabinet breather | |
| 1100 | Filter mat, control cabinet | |
| 1150 | Filter mat, converter cabinet | |
| 1250 | Air filter insert | |
| 1252 | Inlet silencer gasket | |
| 1600 | OMEGA FLUID | |
| 1800 | Drive belt | |
| 2410 | Check valve | X |
| 2440 | Vacuum limiting valve | |
| 4050 | OMEGA blower block | |
| 4200 | Airend pulley | |
| 4205 | Tapered bushing, airend | |
| 4450 | Drive motor | |
| 4550 | Drive motor pulley | |
| 4555 | Tapered bushing, drive motor | |
| 4700 | Fan unit | X |
| 4940 | Control cabinet fan SFC | |
| 7790 | Compensator, air inlet | X |
| 7800 | Compensator, air outlet | X |

11.4 KAESER AIR SERVICE

KAESER AIR SERVICE offers:

- authorized KAESER service representatives with KAESER factory training,
- increased operational reliability ensured by preventive maintenance,
- energy savings achieved by avoidance of pressure losses,
- optimum conditions for operation of the compressed air system,
- the security of genuine KAESER spare parts,
- increased legal certainty as all regulations are kept to.

➤ Why not sign a KAESER AIR SERVICE maintenance agreement!

Result Your advantage:
lower costs and higher compressed air availability.

11.5 Completing the contamination declaration

Every company (user) is responsible for the health and safety of its employees. This extends to personnel who carry out servicing work at the user or service contractor.

A Declaration of Contamination must be completed and signed whenever maintenance or repair work is to be carried out on the machine.

1. Contact KAESER SERVICE and request the contamination declaration form.
2. Attach a copy of the Declaration of Contamination to the **outside** of the packing.

12 Decommissioning, Storage and Transport

12.1 Decommissioning

Decommissioning is necessary, for example, under the following circumstances:

- The machine is temporarily not needed,
- The machine is to be moved to another location,
- The machine is to be scrapped.

Temporary decommissioning

Precondition The machine can be started at regular intervals.

- Run the machine once a week for at least 30 minutes at operating temperature to ensure corrosion protection.

Long-term decommissioning

Precondition The power supply disconnecting device is switched off, the device is locked off, the absence of voltage has been verified, the machine is fully vented.

1. Allow the machine to completely cool down.
2. Disconnect all air and electrical connections.
3. Relax the drive belt.
4. Spray the machine inside and out with a preservative to prevent corrosion.
5. Store the machine in a dry, frost-proof room.

Further information Details of preservatives can be found in chapter 12.4.

12.2 Packing

A wooden crate is required for overland transport to protect the machine from mechanical damage. Other measures must be taken for the transport of machines by sea or air. Please contact an authorized KAESER SERVICE for more information.

Material Protective plastic sheeting
Wooden transport crate

Precondition The machine is decommissioned.
The machine is dry and cooled down.

1. Wrap the machine fully in plastic sheeting.
2. Protect the machine in a wooden crate against mechanical damages.

12.3 Transport

12.3.1 Safety

Weight and center of gravity determine the most suitable method of transportation. Both are specified in the dimensional drawings in chapter 13.2.

Precondition Transport only by pallet truck, forklift truck or lifting gear by personnel trained in the safe transportation of loads.

- Ensure the danger area is clear of personnel.

12.3.2 Transport machine with a pallet truck or forklift truck

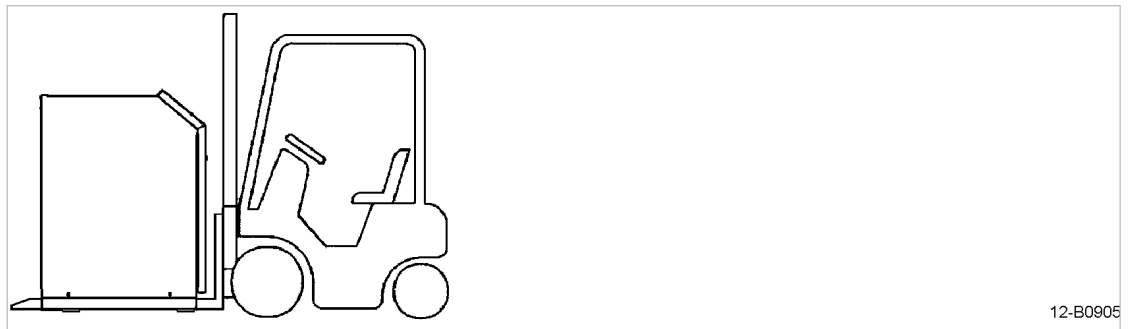

Fig. 33 Transport

1. Remove the cover plate from the sound enclosure's frame (see chapter 6.7).
2. Take note of the center of gravity.
3. Drive the pallet truck fully or forklift truck beneath the entire machine and transport with care.

12.4 Storage

Moisture can lead to corrosion, particularly on the surfaces of the blower block. The storage temperature must not fall below -86°F .



Should you have any questions concerning the correct storage and recommissioning procedure, KAESER will be glad to assist you.

CAUTION

*Rotating lobes!
Danger of crushing or severing limbs.*

- *Do not reach into the interior of the blower block.*
- *If full protection is only provided when the machine is completely installed, then in all other phases of the machine's life-cycle temporary protective devices (e.g. covers) must be fitted, in order to guarantee that parts of the body cannot reach or be caught/sucked in by the rotary lobes.*

NOTICE

Moisture and frost can damage the machine.

- *Prevent the ingress of moisture and formation of condensation.*

- Store the machine in a dry, frost-proof room.
- Seal off the inlet and discharge ports to prevent the ingress of dirt.
- Every month, manually turn the motor shaft by approx. 30°.
- Change the lubricating oil annually.

After long-term storage

- Observe the procedures for assembly and initial commissioning.

12.5 Disposal

When disposing of a machine, drain out all liquids and remove old filters.

Precondition The machine is decommissioned.

1. Completely drain the oil from the machine.
2. Remove old filters.
3. Hand the machine over to an authorized disposal expert.



- Components contaminated with oil must be disposed of in accordance with local environmental protection regulations.

13 Annex

13.1 Pipeline and instrument flow diagram (P+I diagram)

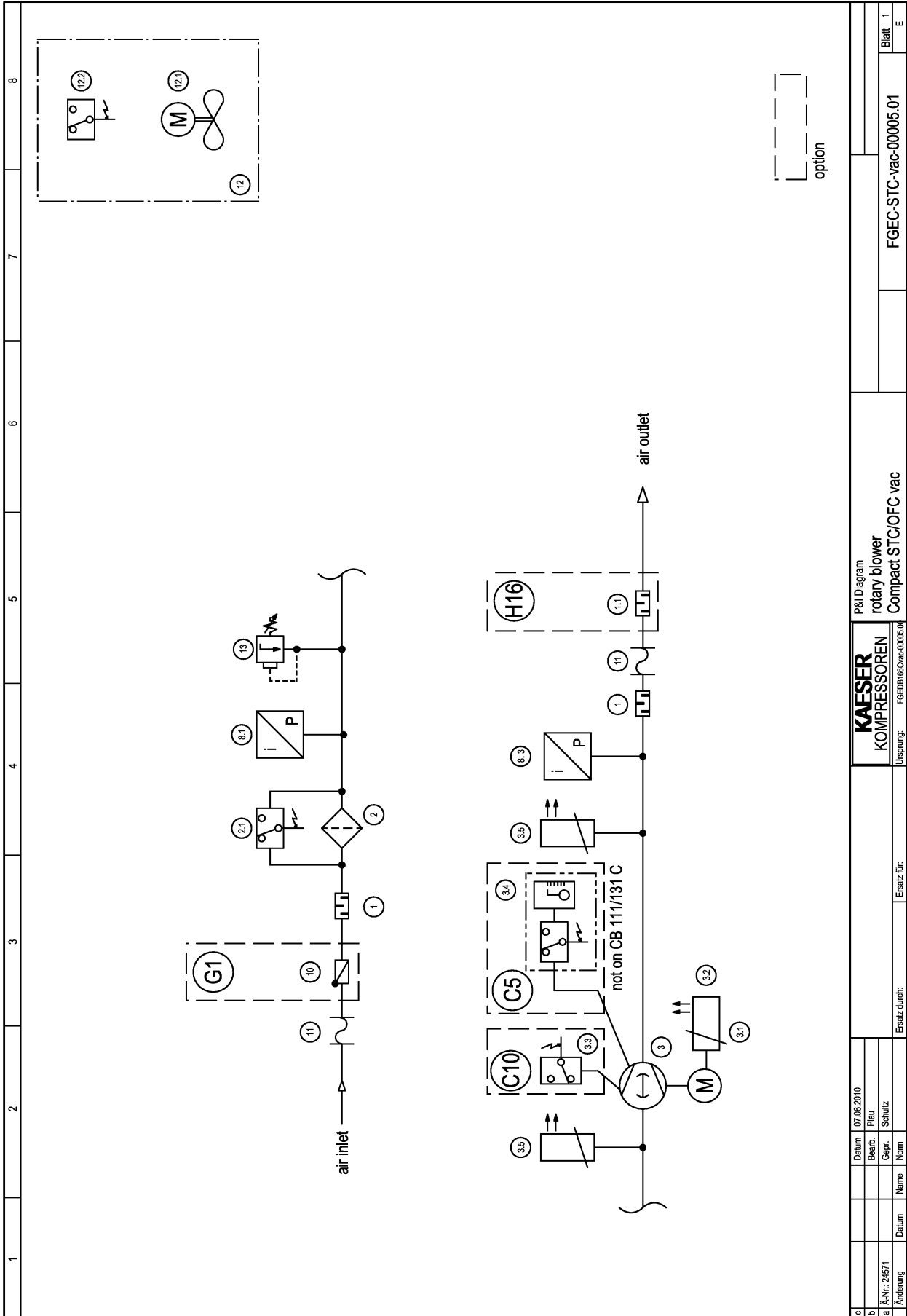

| | | | | |
|----------|--|------------|-------------------------------|--|
| Date | | 07.06.2010 | P&I Diagram | |
| Bearb. | | Pfeu | rotary blower | |
| Gepr. | | Schulz | Compact STC/OFC vac | |
| Name | | | Ersatz für: | |
| Datum | | | Ersatz durch: | |
| Änderung | | | Ursprung: FGEB166vac-00005.01 | |
| | | | FGEC-STC-vac-00005.01 | |
| | | | Blatt 1 | |
| | | | E | |

13.2 Dimensional drawing

13.3 Sound emission

The values for sound pressure levels and sound power levels are provided in the tables below:
Each table discusses one model.

The values applicable to the machine result from the combination of the blower block speed and the differential pressure.

If the texts of the tables are not provided in the chosen language, a translation can be found here.

| | Table legend |
|----|-------------------------|
| a) | Type |
| b) | Without sound enclosure |
| c) | With sound enclosure |
| d) | Blower block speed |
| e) | Pressure differential |
| f) | Sound pressure level |
| g) | Sound power level |

Tab. 42 Sound emission - legend

| a) FB441C | | | b) without sound enclosure | | c) with sound enclosure | |
|----------------------|--------------------------|-------|----------------------------|----------------------|-------------------------|----------------------|
| d) block speed | e) pressure differential | | f) sound level | g) sound power level | f) sound level | g) sound power level |
| [min ⁻¹] | [mbar] | [psi] | [dB(A)] | [dB(A)] | [dB(A)] | [dB(A)] |
| | | | ± 3 dB(A) | ± 3 dB(A) | ± 3 dB(A) | ± 3 dB(A) |
| 2350 | 200 | 3 | 83 | 100 | 73 | 91 |
| 2350 | 300 | 4 | 84 | 101 | 73 | 91 |
| 2350 | 400 | 6 | 86 | 103 | 73 | 91 |
| 2350 | 500 | 7 | 88 | 105 | 74 | 91 |
| 2490 | 200 | 3 | 84 | 101 | 73 | 91 |
| 2490 | 300 | 4 | 85 | 102 | 73 | 91 |
| 2490 | 400 | 6 | 87 | 104 | 73 | 91 |
| 2490 | 500 | 7 | 88 | 106 | 73 | 91 |
| 2640 | 200 | 3 | 84 | 101 | 73 | 91 |
| 2640 | 300 | 4 | 86 | 103 | 73 | 91 |
| 2640 | 400 | 6 | 87 | 105 | 73 | 91 |
| 2640 | 500 | 7 | 89 | 106 | 73 | 91 |
| 2780 | 200 | 3 | 85 | 102 | 73 | 91 |
| 2780 | 300 | 4 | 86 | 104 | 73 | 91 |
| 2780 | 400 | 6 | 88 | 105 | 73 | 91 |
| 2780 | 500 | 7 | 90 | 107 | 73 | 91 |
| 2950 | 200 | 3 | 86 | 103 | 73 | 91 |
| 2950 | 300 | 4 | 87 | 105 | 73 | 91 |
| 2950 | 400 | 6 | 89 | 106 | 73 | 91 |
| 2950 | 500 | 7 | 90 | 107 | 73 | 91 |
| 3110 | 200 | 3 | 86 | 103 | 75 | 93 |
| 3110 | 300 | 4 | 88 | 105 | 73 | 91 |
| 3110 | 400 | 6 | 89 | 106 | 75 | 93 |
| 3110 | 500 | 7 | 91 | 108 | 74 | 91 |
| 3300 | 200 | 3 | 87 | 104 | 73 | 91 |
| 3300 | 300 | 4 | 89 | 107 | 73 | 91 |
| 3300 | 400 | 6 | 90 | 107 | 73 | 91 |
| 3300 | 500 | 7 | 91 | 108 | 73 | 91 |
| 3480 | 200 | 3 | 88 | 105 | 75 | 93 |
| 3480 | 300 | 4 | 91 | 108 | 75 | 93 |
| 3480 | 400 | 6 | 90 | 108 | 76 | 94 |
| 3480 | 500 | 7 | 92 | 109 | 73 | 91 |
| 3690 | 200 | 3 | 89 | 106 | 75 | 93 |
| 3690 | 300 | 4 | 92 | 109 | 75 | 93 |
| 3690 | 400 | 6 | 91 | 108 | 76 | 94 |
| 3690 | 500 | 7 | 92 | 109 | 76 | 94 |

| d) block speed [min ⁻¹] | a) FB621C | | b) without sound enclosure | | c) with sound enclosure | |
|--|--------------------------|-------|----------------------------|----------------------|-------------------------|----------------------|
| | e) pressure differential | | f) sound level | g) sound power level | f) sound level | g) sound power level |
| | [mbar] | [psi] | [dB(A)] | [dB(A)] | [dB(A)] | [dB(A)] |
| | | | ± 3 dB(A) | ± 3 dB(A) | ± 3 dB(A) | ± 3 dB(A) |
| 2350 | 200 | 3 | 87 | 104 | 74 | 91 |
| 2350 | 300 | 4 | 88 | 105 | 74 | 91 |
| 2350 | 400 | 6 | 89 | 106 | 74 | 91 |
| 2350 | 500 | 7 | 90 | 107 | 75 | 93 |
| 2490 | 200 | 3 | 88 | 105 | 73 | 91 |
| 2490 | 300 | 4 | 89 | 106 | 73 | 91 |
| 2490 | 400 | 6 | 90 | 107 | 73 | 91 |
| 2490 | 500 | 7 | 90 | 108 | 74 | 92 |
| 2640 | 200 | 3 | 89 | 106 | 73 | 91 |
| 2640 | 300 | 4 | 90 | 107 | 73 | 91 |
| 2640 | 400 | 6 | 91 | 108 | 73 | 91 |
| 2640 | 500 | 7 | 91 | 108 | 74 | 91 |
| 2780 | 200 | 3 | 89 | 106 | 73 | 91 |
| 2780 | 300 | 4 | 90 | 107 | 73 | 91 |
| 2780 | 400 | 6 | 91 | 108 | 73 | 91 |
| 2780 | 500 | 7 | 92 | 109 | 73 | 91 |
| 2950 | 200 | 3 | 90 | 107 | 74 | 91 |
| 2950 | 300 | 4 | 91 | 108 | 74 | 91 |
| 2950 | 400 | 6 | 92 | 109 | 74 | 91 |
| 2950 | 500 | 7 | 92 | 109 | 74 | 92 |
| 3110 | 200 | 3 | 90 | 108 | 74 | 92 |
| 3110 | 300 | 4 | 91 | 109 | 74 | 92 |
| 3110 | 400 | 6 | 92 | 110 | 74 | 92 |
| 3110 | 500 | 7 | 93 | 110 | 75 | 93 |
| 3300 | 200 | 3 | 91 | 108 | 79 | 97 |
| 3300 | 300 | 4 | 92 | 109 | 79 | 97 |
| 3300 | 400 | 6 | 93 | 110 | 79 | 97 |
| 3300 | 500 | 7 | 93 | 110 | 79 | 97 |
| 3480 | 200 | 3 | 92 | 109 | 79 | 97 |
| 3480 | 300 | 4 | 92 | 109 | 79 | 97 |
| 3480 | 400 | 6 | 93 | 110 | 79 | 97 |
| 3480 | 500 | 7 | 94 | 111 | 79 | 97 |

| a) FB791C | | | b) without sound enclosure | | c) with sound enclosure | |
|----------------------|--------------------------|-------|----------------------------|----------------------|-------------------------|----------------------|
| d) block speed | e) pressure differential | | f) sound level | g) sound power level | f) sound level | g) sound power level |
| [min ⁻¹] | [mbar] | [psi] | [dB(A)] | [dB(A)] | [dB(A)] | [dB(A)] |
| | | | ± 3 dB(A) | ± 3 dB(A) | ± 3 dB(A) | ± 3 dB(A) |
| 2350 | 200 | 3 | 90 | 108 | 77 | 95 |
| 2350 | 300 | 4 | 91 | 109 | 77 | 95 |
| 2350 | 400 | 6 | 92 | 110 | 77 | 95 |
| 2350 | 450 | 7 | 93 | 111 | 77 | 95 |
| 2490 | 200 | 3 | 91 | 108 | 77 | 95 |
| 2490 | 300 | 4 | 92 | 109 | 77 | 95 |
| 2490 | 400 | 6 | 93 | 110 | 77 | 95 |
| 2490 | 450 | 7 | 94 | 111 | 77 | 95 |
| 2640 | 200 | 3 | 92 | 109 | 77 | 95 |
| 2640 | 300 | 4 | 93 | 110 | 77 | 95 |
| 2640 | 400 | 6 | 94 | 111 | 77 | 95 |
| 2640 | 450 | 7 | 95 | 112 | 77 | 95 |
| 2780 | 200 | 3 | 92 | 110 | 77 | 95 |
| 2780 | 300 | 4 | 93 | 111 | 77 | 95 |
| 2780 | 400 | 6 | 94 | 112 | 77 | 95 |
| 2780 | 450 | 7 | 95 | 113 | 77 | 95 |
| 2950 | 200 | 3 | 93 | 110 | 77 | 95 |
| 2950 | 300 | 4 | 94 | 111 | 77 | 95 |
| 2950 | 400 | 6 | 95 | 112 | 77 | 95 |
| 2950 | 450 | 7 | 96 | 114 | 78 | 96 |
| 3110 | 200 | 3 | 93 | 111 | 77 | 95 |
| 3110 | 300 | 4 | 94 | 112 | 77 | 95 |
| 3110 | 400 | 6 | 95 | 113 | 77 | 95 |
| 3110 | 450 | 7 | 97 | 115 | 79 | 96 |
| 3200 | 200 | 3 | 94 | 111 | 77 | 95 |
| 3200 | 300 | 4 | 95 | 112 | 77 | 95 |
| 3200 | 400 | 6 | 96 | 113 | 78 | 95 |
| 3200 | 450 | 7 | 97 | 115 | 79 | 97 |

13.4 Electrical diagrams**13.4.1 Option C33, START CONTROL (STC)**

| | | | | | | | |
|--|---|----------|---|------------------------------|---|--------|---|
| 1 | 2 | 3 | 4 | 5 | 6 | 7 | 8 |
| <div style="border: 1px solid black; padding: 10px; margin: 0 auto; width: 80%;"> <p style="font-size: 1.2em; margin: 0;">Wiring Diagram</p> <p style="font-size: 1.2em; margin: 0;">Blower with wye-delta start</p> <p style="margin: 0;">+ SIGMA CONTROL 2 (SC2)</p> <p style="margin: 0;">230V ±10% 3ph 60Hz 5hp-40hp (4kW-30kW)</p> <p style="margin: 0;">460V ±10% 3ph 60Hz 5hp-175hp (4kW-132kW)</p> <p style="margin: 0;">575V ±10% 3ph 60Hz 5hp-175hp (4kW-132kW)</p> <p style="margin: 0;">Power supply: WYE system with center point solidly grounded</p> </div> | | | | | | | |
| <p>KAESER KOMPRESSOREN SE Postfach 2143 96410 Coburg</p> | | | | | | | |
| <p>ATTENTION !!! The document gives collective information on power supply voltages and frequencies for all machines. The voltage and frequency and local conditions under which any particular machine may be used are given on the nameplate of the machine and in the accompanying service manual.</p> | | | | | | | |
| <p>The drawings remain our exclusive property. They are entrusted only for the agreed purpose. Copies or any other reproductions, including storage, treatment and dissemination by use of electronic systems must not be made for any other than the agreed purpose. Neither originals nor reproductions must be forwarded or otherwise made accessible to third parties.</p> | | | | | | | |
| | | Date | | 14.12.2020 | | USE | |
| | | Drawn | | M.Zeeth | | | |
| | | Released | | M.Zeeth | | | |
| A. Change | | Date | | Name | | | |
| KAESER KOMPRESSOREN <small>SXB.STC-U3010.02</small> | | | | cover page Blower STC+SC2 | | | |
| | | | | = | | + | |
| | | | | DXB.STC-U3020.06 | | page 1 | |
| | | | | | | 1 Sht. | |

| Lfd. Nr. No. | Benennung Name | Zeichnungsnummer (Kunde) Drawing No. (customer) | Zeichnungsnummer (Hersteller) Drawing No. (manufacturer) | Blatt Page | Anlagenkennzeichen Unit designation |
|-----------------|------------------------------------|--|---|---------------|--|
| 46 | terminal connection | -X15,-X16,-X21,-X22,-X100 | KXB.STC-U3020.06 | 2 | |
| 47 | lay-out control panel BBxxx | | AXB.STC-U3020.06 | 1 | |
| 48 | lay-out control panel CB/DB xxx | | AXB.STC-U3020.06 | 2 | |
| 49 | lay-out control panel EBxxx | | AXB.STC-U3020.06 | 3 | |
| 50 | lay-out control panel FBxxx | | AXB.STC-U3020.06 | 4 | |

| | | | | | | | |
|---|----------|------------|------------------|---|---|------------------|-----------|
| c | Date | 14.12.2020 | list of contents | = | + | ZXB.STC-U3020.06 | page 2 |
| b | Drawn | M.Zeesh | | | | | |
| a | Released | M.Zeesh | | | | | |
| B | Change | Date | Name | | | | |

| | | | | | | | | | | | | | | | | | | | | | | | | | | | | | | | | | | | | | | | | | | | | | | | | | | |
|---|----------|---------|------------|---|---|---|---|------------------|---|------|------------|-------------------------------|--------|--|--|---------------|--|--|---|-------|---------|--|---|--|--|--|---|---|------|---|----------|---------|--|------------------|--|--|--|---|--------|---|--------|------|------|--|--|--|--|--|--|--|
| 1 | 2 | 3 | 4 | 5 | 6 | 7 | 8 | | | | | | | | | | | | | | | | | | | | | | | | | | | | | | | | | | | | | | | | | | | |
| <p>general instructions</p> <p>ATTENTION !!! Install supplies, grounding and shock protection to local safety regulations. Control circuits are single-end-grounded, if they are floating they may only be used together with insulation monitoring. Do not make or break live plug-in connectors.</p> <p>control cabinet wiring for non-designated conductors with multi-standard stranded conductors primary circuits: control voltage AC 115V: control voltage AC 115V grounded: control voltage DC 24V: control voltage DC 24V grounded: external voltage: ground conductor:</p> <p>black 2,5mm² H07V-K, 14AWG UL-Style 1015, CSA-TEW red 1mm² H05V-K, 18AWG UL-Style 1015, CSA-TEW white 1mm² H05V-K, 18AWG UL-Style 1015, CSA-TEW blue 1mm² H05V-K, 18AWG UL-Style 1015, CSA-TEW blue/white 1mm² H05V-K, 18AWG UL-Style 1015, CSA-TEW orange 1,5mm² H07V-K, 16AWG UL-Style 1015, CSA-TEW green/yellow H07V-K, UL-Style 1015, CSA-TEW</p> | | | | | | | | | | | | | | | | | | | | | | | | | | | | | | | | | | | | | | | | | | | | | | | | | | |
| <p>-----</p> <p>type model-dependent components</p> <p>B13 = mode of operation overpressure B14 = mode of operation Vacuum C5 = option oil level monitoring (-B80/-B81) (standard by Screw blowers) C10 = option Speed monitoring (-K26+sensor -B90) C11 = option Unloaded start valve C33 = START CONTROL C39 = option oil temperature monitoring (-B55) (standard by Screw blowers) xxx = Gear housing ventilation+Oil return (only EBS/FBS)</p> | | | | | | | | | | | | | | | | | | | | | | | | | | | | | | | | | | | | | | | | | | | | | | | | | | |
| <table border="1" style="width: 100%; border-collapse: collapse;"> <tr> <td style="width: 5%; text-align: center;">c</td> <td style="width: 15%;"></td> <td style="width: 15%; text-align: center;">Date</td> <td style="width: 15%; text-align: center;">14.12.2020</td> <td colspan="4" style="text-align: center;">KAESER KOMPRESSOREN</td> <td style="width: 15%; text-align: center;">block diagram</td> <td style="width: 10%;"></td> <td style="width: 10%;"></td> </tr> <tr> <td style="text-align: center;">b</td> <td style="text-align: center;">Drawn</td> <td style="text-align: center;">M.Zeesh</td> <td></td> <td colspan="4" rowspan="2" style="text-align: center;">Blower STC+SC2 instructions + option</td> <td style="text-align: center;">=</td> <td style="text-align: center;">+</td> <td style="text-align: center;">page</td> </tr> <tr> <td style="text-align: center;">a</td> <td style="text-align: center;">Released</td> <td style="text-align: center;">M.Zeesh</td> <td></td> <td colspan="4" style="text-align: center;">UXB-STC-U3020.06</td> <td style="text-align: center;">1</td> <td style="text-align: center;">28 Sht</td> </tr> <tr> <td style="text-align: center;">C</td> <td style="text-align: center;">Change</td> <td style="text-align: center;">Date</td> <td style="text-align: center;">Name</td> <td colspan="7"></td> </tr> </table> | | | | | | | | c | | Date | 14.12.2020 | KAESER KOMPRESSOREN | | | | block diagram | | | b | Drawn | M.Zeesh | | Blower STC+SC2 instructions + option | | | | = | + | page | a | Released | M.Zeesh | | UXB-STC-U3020.06 | | | | 1 | 28 Sht | C | Change | Date | Name | | | | | | | |
| c | | Date | 14.12.2020 | KAESER KOMPRESSOREN | | | | block diagram | | | | | | | | | | | | | | | | | | | | | | | | | | | | | | | | | | | | | | | | | | |
| b | Drawn | M.Zeesh | | Blower STC+SC2 instructions + option | | | | = | + | page | | | | | | | | | | | | | | | | | | | | | | | | | | | | | | | | | | | | | | | | |
| a | Released | M.Zeesh | | | | | | UXB-STC-U3020.06 | | | | 1 | 28 Sht | | | | | | | | | | | | | | | | | | | | | | | | | | | | | | | | | | | | | |
| C | Change | Date | Name | | | | | | | | | | | | | | | | | | | | | | | | | | | | | | | | | | | | | | | | | | | | | | | |

| | 1 | 2 | 3 | 4 | 5 | 6 | 7 | 8 |
|--|--|--|---|---|---|---|---|---|
| | -B1/-B4 -B5 -B21 -B24 -B40/-B43 -B55 -B59 -B60 -B70 -B80/-B81 -B90 | pressure transducer (4...20mA) differential pressure switch filter clogging overload relay motor Blower overload relay vent motor soundproofing casing temperature probe Blower (PT100) temperature probe PT100 (option) thermal overload releasing relay thermistor, compressor motor temperature probe soundproofing casing oil level switch speed sensors | | | | | | |
| | -1FU -2FU -3FU -9FU -10FU -12FU -29FU | fuse control voltage tapping primary control fuse control transformer secondary control fuse control transformer fuse start unloading ball valve (-M23/-M24) fuse 24V-AC fuse auto-transformer 575V/460V fuse phase sequence relay | | | | | | |
| | -K1 -K10 -K20 -K21 -K26 -K29 -K52 -K53 -K55 -K60 | solenoid valve solenoid valve Oil return SIGMA CONTROL 2 (SC2) (MCS) SIGMA CONTROL 2 (SC2) (IOM-Modul) speed supervisory module phase sequence relay coupling relay solenoid valve coupling relay start unloading ball valve (-M23/-M24) coupling relay Oil return contactor EMERGENCY STOP (external/customer) | | | | | | |
| | -M1 -M4 -M10 -M23 -M24 | motor Blower ventilator soundproofing casing vacuum pump Gear housing ventilation motor start unloading ball valve motor start unloading ball valve | | | | | | |
| | -Q1 -Q2 -Q3 -Q4 | main contactor delta contactor wye contactor contactor ventilator soundproofing casing | | | | | | |
| | -S1 -S9 | EMERGENCY STOP pushbutton REMOTE reset fault message | | | | | | |
| | -T11 -T12 -T21 -T45 | control transformer 230V-AC auto-transformer 575V/460V control voltage supply 24V-DC isolating amplifier | | | | | | |
| | -X0 -X11 -X12 -X15 -X16 -X21 -X22 -X100 | terminal strip, power supply terminal strip, control SC2-IOM digital outputs SC2-IOM digital inputs analog signals (external) control voltage 24V-DC not used EMERGENCY STOP (external/customer) | | | | | | |
| | -K20 | Main Control System SC2 MCS | | | | | | |
| | -X1 -X2 -X3 -X4 -X5 -X6 | Ethernet IO-BUS RS485-FC (USS-Bus) communication module SD card slot ground connection | | | | | | |
| | -K21 | IO-Modul SC2 IOM-1 inside | | | | | | |
| | -X1 -X2 -X3 -X4 | IO-Bus input IO-Bus output digital inputs power supply unit and Transistor outputs | | | | | | |
| | -X5,-X9 -X6 -X7 -X8 | Relay outputs analog input 0-20mA analog input PT100 digital inputs | | | | | | |
| | -X11...-X13 -X14...-X17 -X18...-X29 -X30...-X32 | external analog inputs 0-20mA analog inputs PT100 digital inputs digital outputs | | | | | | |

| | | | | | | | |
|---|--|----------------|------------|------------------|--|--------|--|
|  | | block diagram | | = + | | page | |
| | | Blower STC+SC2 | | UXB-STC-U3020.06 | | 28 Sht | |
| C: Change | | Date | Name | component legend | | | |
| c | | Date | 14.12.2020 | | | | |
| b | | Drawn | M.Zeeh | | | | |
| a | | Released | M.Zeeh | | | | |

| model | Common parts | | | |
|---|--|--|--|--|
| | 5 - 20 hp | 5 - 20 hp | 5 - 175 hp | 5 - 175 hp |
| machine power supply | 208 V ±10 %, 60 Hz (4-15 kW) | 230 V ±10 %, 60 Hz (4-15 kW) | 460 V ±10 %, 60 Hz (4-132 kW) | 575 V ±10 %, 60 Hz (4-132 kW) |
| pressure transducer -B1 Huba Control | 894786.0 0.-1200mbar | 894786.0 0.-1200mbar | 894786.0 0.-1200mbar | 894786.0 0.-1200mbar |
| pressure transducer -B4 Huba Control | 894787.0 0.1200mbar | 894787.0 0.1200mbar | 894787.0 0.1200mbar | 894787.0 0.1200mbar |
| differential pressure switch -B5 Dungs | 893307.00010 setting: 14,1 in.W.C. | 893307.00010 setting: 14,1 in.W.C. | 893307.00010 setting: 14,1 in.W.C. | 893307.00010 setting: 14,1 in.W.C. |
| temperature probe -B40/-B43 WIKA | 895251.10010 (BB/CB/DB) 895251.10040 (EB-C/FB) 895603.00040 (EB-S) Pt100 | 895251.10010 (BB/CB/DB) 895251.10040 (EB-C/FB) 895603.00040 (EB-S) Pt100 | 895251.10010 (BB/CB/DB) 895251.10040 (EB-C/FB) 895603.00040 (EB-S) Pt100 | 895251.10010 (BB/CB/DB) 895251.10040 (EB-C/FB) 895603.00040 (EB-S) Pt100 |
| temperature probe -B55 | 895251.10100 895603.00100 (EB-S) Pt100 | 895251.10100 895603.00100 (EB-S) Pt100 | 895251.10100 895603.00100 (EB-S) Pt100 | 895251.10100 895603.00100 (EB-S) Pt100 |
| thermal overload releasing relay -B59 Ziehl | 7.2711.00040 MS220K 24 V UC | 7.2711.00040 MS220K 24 V UC | 7.2711.00040 MS220K 24 V UC | 7.2711.00040 MS220K 24 V UC |
| temperature probe -B70 Wieland | 895393.10400 (BB/CB/DB) 895393.10410 (EB) 895393.10420 (FB) Pt100 | 895393.10400 (BB/CB/DB) 895393.10410 (EB) 895393.10420 (FB) Pt100 | 895393.10400 (BB/CB/DB) 895393.10410 (EB) 895393.10420 (FB) Pt100 | 895393.10400 (BB/CB/DB) 895393.10410 (EB) 895393.10420 (FB) Pt100 |
| fuse -1FU Gould | (3x) - 7.3161.00190 ATQR 8 A - 600 V - class CC | (3x) - 7.3161.00190 ATQR 8 A - 600 V - class CC | (3x) - 7.3161.00190 ATQR 8 A - 600 V - class CC | (3x) - 7.3161.00190 ATQR 8 A - 600 V - class CC |
| fuse -2FU Gould | (2x) - 7.3161.00160 ATQR 5 A - 600 V - class CC | (2x) - 7.3161.00141 ATQR 4 A - 600 V - class CC | (2x) - 7.3317.1 ATQR 3 A - 600 V - class CC | (2x) - 7.3317.1 ATQR 3 A - 600 V - class CC |
| fuse -3FU Gould | (1x) - 7.3161.00160 ATQR 5 A - 600 V - class CC | (1x) - 7.3161.00160 ATQR 5 A - 600 V - class CC | (1x) - 7.3161.00160 ATQR 5 A - 600 V - class CC | (1x) - 7.3161.00160 ATQR 5 A - 600 V - class CC |
| fuse -29FU Gould | (3x) - 7.3161.00360 ATDR 1 A - 600 V - class CC | (3x) - 7.3161.00360 ATDR 1 A - 600 V - class CC | (3x) - 7.3161.00360 ATDR 1 A - 600 V - class CC | (3x) - 7.3161.00360 ATDR 1 A - 600 V - class CC |
| fuse socket -1FU/-29FU -2FU -3FU Wöhner | 3-pole (2x) - 7.3320.00060 2-pole (1x) - 7.3320.00070 1-pole (1x) - 7.3320.00050 class CC - Ambus Easy Switch | 3-pole (2x) - 7.3320.00060 2-pole (1x) - 7.3320.00070 1-pole (1x) - 7.3320.00050 class CC - Ambus Easy Switch | 3-pole (2x) - 7.3320.00060 2-pole (1x) - 7.3320.00070 1-pole (1x) - 7.3320.00050 class CC - Ambus Easy Switch | 3-pole (2x) - 7.3320.00060 2-pole (1x) - 7.3320.00070 1-pole (1x) - 7.3320.00050 class CC - Ambus Easy Switch |
| fuse -10FU | 895637.0 5x20 0,315 A-T 250 VAC | 895637.0 5x20 0,315 A-T 250 VAC | 895637.0 5x20 0,315 A-T 250 VAC | 895637.0 5x20 0,315 A-T 250 VAC |
| solenoid valve -K10 bürkert | 895601.0 24V-DC 8W | 895601.0 24V-DC 8W | 895601.0 24V-DC 8W | 895601.0 24V-DC 8W |
| Blower control -K20 Prodrive | 7.7601.0 SC2MCS | 7.7601.0 SC2MCS | 7.7601.0 SC2MCS | 7.7601.0 SC2MCS |
| Blower control -K21 Prodrive | 7.7602.1 SC2IOM-1 | 7.7602.1 SC2IOM-1 | 7.7602.1 SC2IOM-1 | 7.7602.1 SC2IOM-1 |
| phase sequence relay -K29 Siemens | 7.7830.00600 3UG4615 | 7.7830.00600 3UG4615 | 7.7830.00600 3UG4615 | 7.7830.00600 3UG4615 |
| coupling relay -K55 Siemens | 7.8237.00340 3RH2122-2JB40 DC 17-30 V AC-15: 230 V/10 A | 7.8237.00340 3RH2122-2JB40 DC 17-30 V AC-15: 230 V/10 A | 7.8237.00340 3RH2122-2JB40 DC 17-30 V AC-15: 230 V/10 A | 7.8237.00340 3RH2122-2JB40 DC 17-30 V AC-15: 230 V/10 A |
| vacuum pump -M10 Schwarzer | 895612.00100 24V-AC 60 Hz, 4W | 895612.00100 24V-AC 60 Hz, 4W | 895612.00100 24V-AC 60 Hz, 4W | 895612.00100 24V-AC 60 Hz, 4W |
| contactor -Q4 Siemens | 7.8740.00310 3RT2016-1AK61 | 7.8740.00310 3RT2016-1AK61 | 7.8740.00310 3RT2016-1AK61 | 7.8740.00310 3RT2016-1AK61 |
| Fortsetzung: nächstes Blatt | | | | |

| | |
|---------------------------------|------------|
| page | 3 |
| 28 Sht | |
| UXB-STC-U3020.06 | |
| electrical component parts list | |
| Blower STC+SC2 | |
| Common parts | |
| KAESER KOMPRESSOREN | |
| Date | 14.12.2020 |
| Drawn | M.Zeesh |
| Released | M.Zeesh |
| Name | |
| Date | |
| C Change | |

| model | Common parts | | | | page 28 Sht | | | | | | |
|---|--|--|--|--|-------------------------------|---|------------|-------|--------|----------|--------|
| | 5 - 20 hp | 5 - 20 hp | 5 - 175 hp | 5 - 175 hp | | | | | | | |
| machine power supply | 208 V ±10 %, 60 Hz (4-15 kW) | 230 V ±10 %, 60 Hz (4-15 kW) | 460 V ±10 %, 60 Hz (4-132 kW) | 575 V ±10 %, 60 Hz (4-132 kW) | = + UXB-STC-U3020.06 | | | | | | |
| interference suppressor Siemens | 7.8740.05130 3RT2916-1CC00 | 7.8740.05130 3RT2916-1CC00 | 7.8740.05130 3RT2916-1CC00 | 7.8740.05130 3RT2916-1CC00 | | | | | | | |
| Not-Halt -S1 | 834424.0 subassembly complete | 834424.0 subassembly complete | 834424.0 subassembly complete | 834424.0 subassembly complete | | | | | | | |
| control transformer -T11 Block | 7.2238.10090 USTE630 - 630 VA 208-600 V/2x 115 V+ 24 V | 7.2238.10090 USTE630 - 630 VA 208-600 V/2x 115 V+ 24 V | 7.2238.10090 USTE630 - 630 VA 208-600 V/2x 115 V+ 24 V | 7.2238.10090 USTE630 - 630 VA 208-600 V/2x 115 V+ 24 V | | | | | | | |
| power supply -T21 Prodrive | 7.7605P0 PSDC24/2.5 100-240 V-AC/24 V-DC 2,5 A | 7.7605P0 PSDC24/2.5 100-240 V-AC/24 V-DC 2,5 A | 7.7605P0 PSDC24/2.5 100-240 V-AC/24 V-DC 2,5 A | 7.7605P0 PSDC24/2.5 100-240 V-AC/24 V-DC 2,5 A | | | | | | | |
| isolating amplifier -T45 Phoenix | 7.2892.00040 MCR-C-1/1-00-DC | 7.2892.00040 MCR-C-1/1-00-DC | 7.2892.00040 MCR-C-1/1-00-DC | 7.2892.00040 MCR-C-1/1-00-DC | | | | | | | |
| control line terminal -X. 11/12/15/16/21/22/100 Handling | 895635.0 Wieland WTP fig. 1, Sht. 11 | 895635.0 Wieland WTP fig. 1, Sht. 11 | 895635.0 Wieland WTP fig. 1, Sht. 11 | 895635.0 Wieland WTP fig. 1, Sht. 11 | | | | | | | |
| | | | | | | electrical component parts list Blower STC+SC2 Common parts | | | | | |
| | | | | | KAESER KOMPRESSOREN | | | | | | |
| | | | | | Date | | 14.12.2020 | Drawn | M.Zeeh | Released | M.Zeeh |
| | | | | | C Change | | | | | | |

| | | | | | | | | |
|---|--------------------------|---|---|---|---|---|--------|--------|
| model | option | | | | = | + | page 5 | 28 Sht |
| | BB | BB | BB | BB | | | | |
| machine power supply | 208 V / 60 Hz | 230 V / 60 Hz | 460 V / 60 Hz | 575 V / 60 Hz | UXB-STC-U3020.06 | | | |
| option C5/C39: oil function monitors | | | | | | | | |
| oil level switch (option C5) | -B80/-B81 Elobau | --- | --- | --- | electrical component parts list Blower STC+SC2 option | | | |
| oil temperature (option C39) | -B55 Wika | --- | --- | --- | | | | |
| option C10: Speed monitoring | | | | | | | | |
| supervisory module | -K26 ifm | 895323.0 FR1 - DD2503 | 895323.0 FR1 - DD2503 | 895323.0 FR1 - DD2503 | KAESER KOMPRESSOREN | | | |
| speed sensor | -B90 ifm | 895039.0 IFC201 | 895039.0 IFC201 | 895039.0 IFC201 | | | | |
| option C11: Unloaded start valve 24 V-DC (electromagnetic) | | | | | | | | |
| solenoid valve | -K1 Riegler | --- | --- | --- | Date 14.12.2020 | | | |
| option C11: Unloaded start valve 115 V-AC (electromagnetic) | | | | | | | | |
| solenoid valve | -K1 bürkert | 893584.00010 115V/60 Hz (1PH/N/GRD) | 893584.00010 115V/60 Hz (1PH/N/GRD) | 893584.00010 115V/60 Hz (1PH/N/GRD) | Drawn M.Zeeh | | | |
| coupling relay | -K52 Wieland | 7.3149.00660 FLARE 24 V-DC 1W-250 V/6 A | 7.3149.00660 FLARE 24 V-DC 1W-250 V/6 A | 7.3149.00660 FLARE 24 V-DC 1W-250 V/6 A | | | | |
| option C11: Unloaded start valve 115 V-AC (ball valve) | | | | | | | | |
| coupling relay | -K53 Siemens | --- | --- | --- | Name | | | |
| actuator drive | -M23 / (-M24) Sun Yeh | --- | --- | --- | | | | |
| fuse | -9FU Gould | --- | --- | --- | C Change | | | |

| model | option | CB-DB-EB | CB-DB-EB | CB-DB-EB | CB-DB-EB | FB |
|---|--------------------------|--|--|--|--|--------------------------|
| machine power supply | | 208 V / 60 Hz | 230 V / 60 Hz | 460 V / 60 Hz | 575 V / 60 Hz | 460 V+ 575 V / 60 Hz |
| option C5/C39: oil function monitors | | | | | | |
| oil level switch (option C5) | -B80/-B81 Elobau | 894631.00010 | 894631.00010 | 894631.00010 | 894631.00010 | 894631.00010 |
| oil temperature (option C39) | -B55 Wika | 895251.10100 (xB-C) 895603.00100 (EB-S) Pt100 | 895251.10100 (xB-C) 895603.00100 (EB-S) Pt100 | 895251.10100 (xB-C) 895603.00100 (EB-S) Pt100 | 895251.10100 (xB-C) 895603.00100 (EB-S) Pt100 | 895251.10100 Pt100 |
| option C10: Speed monitoring | | | | | | |
| supervisory module | -K26 ifm | 895323.0 FR1 - DD2503 | 895323.0 FR1 - DD2503 | 895323.0 FR1 - DD2503 | 895323.0 FR1 - DD2503 | 895323.0 FR1 - DD2503 |
| speed sensor | -B90 ifm | 895039.0 IFC201 | 895039.0 IFC201 | 895039.0 IFC201 | 895039.0 IFC201 | 895039.0 IFC201 |
| option C11: Unloaded start valve 24 V-DC (electromagnetic) (only EBS+ FBS) | | | | | | |
| solenoid valve | -K1 Riegler | 894204.00020 24V - DC | 894204.00020 24V - DC | 894204.00020 24V - DC | 894204.00020 24V - DC | 894204.00020 24V - DC |
| option C11: Unloaded start valve 115 V-AC (ball valve) (only EBS) | | | | | | |
| coupling relay | -K53 Siemens | 7.8237.00340 3RH2122-2JB40 DC 17-30 V AC-15: 240 V/10 A | 7.8237.00340 3RH2122-2JB40 DC 17-30 V AC-15: 240 V/10 A | 7.8237.00340 3RH2122-2JB40 DC 17-30 V AC-15: 240 V/10 A | 7.8237.00340 3RH2122-2JB40 DC 17-30 V AC-15: 240 V/10 A | --- --- --- --- |
| actuator drive | -M23 / (-M24) Sun Yeh | 895449.00010 OM-1 110 V | 895449.00010 OM-1 110 V | 895449.00010 OM-1 110 V | 895449.00010 OM-1 110 V | --- --- |
| fuse | -9FU Gould | 7.3304.00010 ATDR 2 A - 600 V class CC | 7.3304.00010 ATDR 2 A - 600 V class CC | 7.3304.00010 ATDR 2 A - 600 V class CC | 7.3304.00010 ATDR 2 A - 600 V class CC | --- --- |
| fuse socket | -9FU Wöhner | 1-pole - 7.3320.00050 cl. CC Ambus Easy Switch | 1-pole - 7.3320.00050 cl. CC Ambus Easy Switch | 1-pole - 7.3320.00050 cl. CC Ambus Easy Switch | 1-pole - 7.3320.00050 cl. CC Ambus Easy Switch | --- --- |

| | |
|---------------------------------|------------|
| page | 28 Sht |
| UXB-STC-U3020.06 | |
| electrical component parts list | |
| Blower STC+SC2 | |
| option | |
| KAESER KOMPRESSOREN | |
| Date | 14.12.2020 |
| Drawn | M.Zeeh |
| Released | M.Zeeh |
| Name | |
| Date | |
| C Change | |

| model | performance-related components | | | | page 7 28 Sht |
|---|--|--|--|--|--|
| | 5 hp BB (4 kW) | 7,5 hp BB+ CB+DB (5,5 kW) | 10 hp BB+ CB+DB (7,5 kW) | 15 hp BB+ CB+DB (11 kW) | |
| machine power supply | 208 V ±10 %, 60 Hz | 208 V ±10 %, 60 Hz | 208 V ±10 %, 60 Hz | 208 V ±10 %, 60 Hz | = + UXB-STC-U3020.06 |
| overload relay -B21 Siemens | 7.8741.00070 3RB3026-1QB0 6-25 A / S0 setting: 7,2 A NEC 430.32(C) incremental setting: 8,1 A | 7.8741.00070 3RB3026-1QB0 6-25 A / S0 setting: 9,8 A NEC 430.32(C) incremental setting: 11,0 A | 7.8741.00070 3RB3026-1QB0 6-25 A / S0 setting: 13,3 A NEC 430.32(C) incremental setting: 15,0 A | 7.8741.00080 3RB3026-1VB0 10-40 A / S0 setting: 19,7 A NEC 430.32(C) incremental setting: 22,2 A | |
| overload relay soundproofing casing -B24 Siemens | 7.8741.00030 3RB3016-1PB0 1,00-4,00 A / S00 setting: 1,43 A NEC 430.32(C) incremental setting: 1,61 A | 7.8741.00030 3RB3016-1PB0 1,00-4,00 A / S00 setting: 1,43 A NEC 430.32(C) incremental setting: 1,61 A | 7.8741.00030 3RB3016-1PB0 1,00-4,00 A / S00 setting: 1,43 A NEC 430.32(C) incremental setting: 1,61 A | 7.8741.00030 3RB3016-1PB0 1,00-4,00 A / S00 setting: 1,43 A NEC 430.32(C) incremental setting: 1,61 A | electrical component parts list 208V BB+CB+DB performance-related components |
| Blower motor -M1 Siemens | 894989.0 208V-DD/60 Hz | 894990.0 208V-DD/60 Hz | 894991.0 208V-DD/60 Hz | 894992.0 208V-DD/60 Hz | |
| vent motor soundproofing casing -M4 ebm | 895260.00010 W2D250 115 V/60 Hz (1PH/N/GRD) 175W 1,55 A | 895260.00010 W2D250 115 V/60 Hz (1PH/N/GRD) 175W 1,55 A | 895260.00010 W2D250 115 V/60 Hz (1PH/N/GRD) 175W 1,55 A | 895260.00010 W2D250 115 V/60 Hz (1PH/N/GRD) 175W 1,55 A | KAESER KOMPRESSOREN |
| contactor -Q1 / -Q2 | 7.8740.00350 3RT2024-1AK60 | 7.8740.00360 3RT2025-1AK60 | 7.8740.00370 3RT2026-1AK60 | 7.8740.00390 3RT2028-1AK60 | |
| auxiliary switch auxiliary switch interference suppressor terminal Phase rail Siemens | 7.8740.05140 3RT2926-1CC00 7.3140.05080 3RV2925-5EB 7.6861.0 3RV1915-1AB | 7.8740.05140 3RT2926-1CC00 7.3140.05080 3RV2925-5EB 7.6861.0 3RV1915-1AB | 7.8740.05140 3RT2926-1CC00 7.3140.05080 3RV2925-5EB 7.6861.0 3RV1915-1AB | 7.8740.05140 3RT2926-1CC00 7.3140.05080 3RV2925-5EB 7.6861.0 3RV1915-1AB | |
| contactor auxiliary switch auxiliary switch interference suppressor wye bridge Siemens | 7.8740.00310 3RT2016-1AK61 7.8740.05010 3RH2911-1HA11 7.8740.05130 3RT2916-1CC00 7.3140.05030 3RT1916-4BA31 | 7.8740.00310 3RT2016-1AK61 7.8740.05010 3RH2911-1HA11 7.8740.05130 3RT2916-1CC00 7.3140.05030 3RT1916-4BA31 | 7.8740.00330 3RT2018-1AK61 7.8740.05010 3RH2911-1HA11 7.8740.05130 3RT2916-1CC00 7.3140.05030 3RT1916-4BA31 | 7.8740.00380 3RT2027-1AK60 7.8740.05140 3RT2926-1CC00 7.3140.02070 3RT1926-4BA31 | |
| motor cable -W19.1/19.2 | 4x14 AWG / 4G2,5 mm ² 600 V - 90°C | 4x14 AWG / 4G2,5 mm ² 600 V - 90°C | 4x12 AWG / 4G4 mm ² 600 V - 90°C | 4x10 AWG / 4G6 mm ² 600 V - 90°C | |
| connection -W11 -W13 -W14 | 10 AWG / 6 mm2 Phase rail 14 AWG / 2,5 mm2 600 V - 90°C | 10 AWG / 6 mm2 Phase rail 14 AWG / 2,5 mm2 600 V - 90°C | 8 AWG / 10 mm2 Phase rail 14 AWG / 2,5 mm2 600 V - 90°C | 8 AWG / 10 mm2 Phase rail Phase rail 14 AWG / 2,5 mm2 600 V - 90°C | |
| supply terminals -X0: U1/V1/W1/GRD | 894864.00010 14-4 AWG / 2,5-16 mm ² Wieland fig. 2, Sht. 11 16 mm | 894864.00010 14-4 AWG / 2,5-16 mm ² Wieland fig. 2, Sht. 11 16 mm | 894864.00010 14-4 AWG / 2,5-16 mm ² Wieland fig. 2, Sht. 11 16 mm | 894864.00010 14-4 AWG / 2,5-16 mm ² Wieland fig. 2, Sht. 11 16 mm | Date 14.12.2020 Drawn M.Zeesh Released M.Zeesh Name Date |
| supply Handling Stripped length X connection | fig. 1, Sht. 12 | fig. 1, Sht. 12 | fig. 1, Sht. 12 | fig. 1, Sht. 12 | |
| C Change | | | | | |

| model | performance-related components | | | | | page 28 Sht |
|--|--|--|--|--|--|--|
| | 20 hp BB+ CB+DB (15 kW) | 25 hp CB+ DB (18,5 kW) | 30 hp CB+ DB (22 kW) | 40 hp CB (30 kW) | 40 hp DB (30 kW) | |
| machine power supply | 208 V ±10 %, 60 Hz | 208 V ±10 %, 60 Hz | 208 V ±10 %, 60 Hz | 208 V ±10 %, 60 Hz | 208 V ±10 %, 60 Hz | = + UXB-STC-U3020.06 |
| overload relay -B21 Siemens | 7.8741.00090 3RB3036-1UB0 12,5-50 A / S2 setting: 26,6 A NEC 430.32(C) incremental setting: 30,0 A | 7.8741.00090 3RB3036-1UB0 12,5-50 A / S2 setting: 31,9 A NEC 430.32(C) incremental setting: 36,0 A | 7.8741.00100 3RB3036-1WB0 20-80 A / S2 setting: 38,2 A NEC 430.32(C) incremental setting: 43,2 A | 7.8741.00100 3RB3036-1WB0 20-80 A / S2 setting: 52,1 A NEC 430.32(C) incremental setting: 58,8 A | 7.8741.00100 3RB3036-1WB0 20-80 A / S2 setting: 54,2 A NEC 430.32(C) incremental setting: 61,2 A | |
| overload relay soundproofing casing -B24 Siemens | 7.8741.00030 3RB3016-1PB0 1,00-4,00 A / S00 setting: 1,43 A NEC 430.32(C) incremental setting: 1,61 A | 7.8741.00030 3RB3016-1PB0 1,00-4,00 A / S00 setting: 1,43 A NEC 430.32(C) incremental setting: 1,61 A | 7.8741.00030 3RB3016-1PB0 1,00-4,00 A / S00 setting: 1,43 A NEC 430.32(C) incremental setting: 1,61 A | 7.8741.00030 3RB3016-1PB0 1,00-4,00 A / S00 setting: 1,43 A NEC 430.32(C) incremental setting: 1,61 A | 7.8741.00030 3RB3016-1PB0 1,00-4,00 A / S00 setting: 1,43 A NEC 430.32(C) incremental setting: 1,61 A | |
| Blower motor -M1 Siemens | 895049.0 208V-DD/60 Hz | 894994.0 208V-DD/60 Hz | 894995.0 208V-DD/60 Hz | 894996.1 (CB) 208V-DD/60 Hz | 894997.1 (DB) 208V-DD/60 Hz | electrical component parts list 208V BB+CB+DB performance-related components |
| vent motor soundproofing casing -M4 ebm | 895260.00010 W2D250 115 V/60 Hz (1PH/N/GRD) 175W 1,55 A | 895260.00010 W2D250 115 V/60 Hz (1PH/N/GRD) 175W 1,55 A | 895260.00010 W2D250 115 V/60 Hz (1PH/N/GRD) 175W 1,55 A | 895260.00010 W2D250 115 V/60 Hz (1PH/N/GRD) 175W 1,55 A | 895260.00010 W2D250 115 V/60 Hz (1PH/N/GRD) 175W 1,55 A | |
| contactor -Q1 / -Q2 | 7.8740.00400 3RT2035-1AK60 | 7.8740.00400 3RT2035-1AK60 | 7.8740.00420 3RT2037-1AK60 | 7.8740.00430 3RT2038-1AK60 | 7.8740.00430 3RT2038-1AK60 | KAESER KOMPRESSOREN |
| auxiliary switch | . | . | . | . | . | |
| auxiliary switch | . | . | . | . | . | |
| interference suppressor | 7.8740.05150 3RT2936-1CC00 | 7.8740.05150 3RT2936-1CC00 | 7.8740.05150 3RT2936-1CC00 | 7.8740.05150 3RT2936-1CC00 | 7.8740.05150 3RT2936-1CC00 | |
| terminal | 7.3140.05070 3RV2935-5E | 7.3140.05070 3RV2935-5E | 7.3140.05070 3RV2935-5E | 7.3140.05070 3RV2935-5E | 7.3140.05070 3RV2935-5E | |
| Phase rail | 7.3140.05270 3RA2933-3FA00 | 7.3140.05270 3RA2933-3FA00 | 7.3140.05270 3RA2933-3FA00 | 7.3140.05270 3RA2933-3FA00 | 7.3140.05270 3RA2933-3FA00 | |
| contactor -Q3 | 7.8740.00400 3RT2035-1AK60 | 7.8740.00400 3RT2035-1AK60 | 7.8740.00400 3RT2035-1AK60 | 7.8740.00400 3RT2035-1AK60 | 7.8740.00400 3RT2035-1AK60 | |
| auxiliary switch | . | . | . | . | . | |
| auxiliary switch | . | . | . | . | . | |
| interference suppressor | 7.8740.05150 3RT2936-1CC00 | 7.8740.05140 3RT2926-1CC00 | 7.8740.05150 3RT2936-1CC00 | 7.8740.05150 3RT2936-1CC00 | 7.8740.05150 3RT2936-1CC00 | |
| wye bridge | 7.3140.01170 3RT1936-4BA31 | 7.3140.02070 3RT1926-4BA31 | 7.3140.01170 3RT1936-4BA31 | 7.3140.01170 3RT1936-4BA31 | 7.3140.01170 3RT1936-4BA31 | |
| motor cable -W19.1/19.2 | 4x8 AWG / 4G10 mm ² 600 V - 90°C | 4x6 AWG / 4G16 mm ² 600 V - 90°C | 4x6 AWG / 4G16 mm ² 600 V - 90°C | 4x4 AWG / 4G25 mm ² 600 V - 90°C | 4x4 AWG / 4G25 mm ² 600 V - 90°C | |
| connection -W11 Phase rail -W13 Phase rail -W14 600 V - 90°C | 4 AWG / 25 mm2 Phase rail Phase rail 600 V - 90°C | 4 AWG / 25 mm2 Phase rail Phase rail 600 V - 90°C | 2 AWG / 35 mm2 Phase rail Phase rail 600 V - 90°C | 1 AWG / 50 mm2 Phase rail Phase rail 600 V - 90°C | 1 AWG / 50 mm2 Phase rail Phase rail 600 V - 90°C | |
| supply terminals -X0: U1/V1/W1/GRD | 3x 895314.0 3x 895314.00010 4x 895314.00040 8-1 AWG / 10-50 mm ² Wago fig. 3, Sht. 11 30 mm | 3x 895314.0 3x 895314.00010 4x 895314.00040 8-1 AWG / 10-50 mm ² Wago fig. 3, Sht. 11 30 mm | 3x 895314.0 3x 895314.00010 4x 895314.00040 8-1 AWG / 10-50 mm ² Wago fig. 3, Sht. 11 30 mm | 3x 894385.0 3x 894385.00010 4x 894385.00040 4-4/0 AWG / 25-95 mm ² Wago fig. 3, Sht. 11 36 mm | 3x 894385.0 3x 894385.00010 4x 894385.00040 4-4/0 AWG / 25-95 mm ² Wago fig. 3, Sht. 11 36 mm | |
| supply Stripped length X connection | fig. 2, Sht. 12 | fig. 2, Sht. 12 | fig. 2, Sht. 12 | fig. 2, Sht. 12 | fig. 2, Sht. 12 | |
| | | | | | | Date 14.12.2020 |
| | | | | | | Drawn M.Zeeh |
| | | | | | | Released M.Zeeh |
| | | | | | | Name |
| | | | | | | Date |
| | | | | | | C Change |

| model | performance-related components | | | page 9 28 Sht |
|---|--|--|--|--|
| | 25 hp EB (18,5 kW) | 30 hp EB (22 kW) | 40 hp EB (30 kW) | |
| machine power supply | 208 V ±10 %, 60 Hz | 208 V ±10 %, 60 Hz | 208 V ±10 %, 60 Hz | = + UXB-STC-U3020.06 |
| overload relay -B21 Siemens | 7.8741.00090 3RB3036-1UB0 12,5-50 A / S2 setting: 31,9 A NEC 430.32(C) incremental setting: 36,0 A | 7.8741.00100 3RB3036-1WB0 20-80 A / S2 setting: 38,2 A NEC 430.32(C) incremental setting: 43,2 A | 7.8741.00100 3RB3036-1WB0 20-80 A / S2 setting: 54,2 A NEC 430.32(C) incremental setting: 61,2 A | |
| overload relay soundproofing casing -B24 Siemens | 7.8741.00020 3RB3016-1NB0 0,32-1,25 A / S00 setting: 0,98 A NEC 430.32(C) incremental setting: 1,10 A | 7.8741.00020 3RB3016-1NB0 0,32-1,25 A / S00 setting: 0,98 A NEC 430.32(C) incremental setting: 1,10 A | 7.8741.00020 3RB3016-1NB0 0,32-1,25 A / S00 setting: 0,98 A NEC 430.32(C) incremental setting: 1,10 A | electrical component parts list 208V EB performance-related components |
| Blower motor -M1 Siemens | 894994.0 208V-DD/60 Hz | 894995.0 208V-DD/60 Hz | 894997.1 208V-DD/60 Hz | |
| vent motor soundproofing casing -M4 Sodeca | 895040.00020 HC-31-2T / H-I-E 208 V-D/60 Hz (3PH/GRD) 180W 1,06 A | 895040.00020 HC-31-2T / H-I-E 208 V-D/60 Hz (3PH/GRD) 180W 1,06 A | 895040.00020 HC-31-2T / H-I-E 208 V-D/60 Hz (3PH/GRD) 180W 1,06 A | |
| contactor -Q1 / -Q2 | 7.8740.00400 3RT2035-1AK60 | 7.8740.00420 3RT2037-1AK60 | 7.8740.00430 3RT2038-1AK60 | KAESER KOMPRESSOREN |
| auxiliary switch | 7.8740.05030 3RH2911-1HA20 | 7.8740.05030 3RH2911-1HA20 | 7.8740.05030 3RH2911-1HA20 | |
| auxiliary switch | . | . | . | |
| interference suppressor | 7.8740.05150 3RT2936-1CC00 | 7.8740.05150 3RT2936-1CC00 | 7.8740.05150 3RT2936-1CC00 | |
| terminal | 7.3140.05070 3RV2935-5E | 7.3140.05070 3RV2935-5E | 7.3140.05070 3RV2935-5E | |
| Phase rail | 7.3140.05270 3RA2933-3FA00 | 7.3140.05270 3RA2933-3FA00 | 7.3140.05270 3RA2933-3FA00 | |
| contactor -Q3 | 7.8740.00400 3RT2035-1AK60 | 7.8740.00400 3RT2035-1AK60 | 7.8740.00400 3RT2035-1AK60 | |
| auxiliary switch | . | . | . | |
| auxiliary switch | . | . | . | |
| interference suppressor | 7.8740.05150 3RT2936-1CC00 | 7.8740.05150 3RT2936-1CC00 | 7.8740.05150 3RT2936-1CC00 | |
| wye bridge | 7.3140.01170 3RT1936-4BA31 | 7.3140.01170 3RT1936-4BA31 | 7.3140.01170 3RT1936-4BA31 | |
| motor cable -W19.1/19.2 | 4x6 AWG / 4G16 mm ² 600 V - 90°C | 4x6 AWG / 4G16 mm ² 600 V - 90°C | 4x4 AWG / 4G25 mm ² 600 V - 90°C | |
| connection -W11 -W13 -W14 | 4 AWG / 25 mm ² Phase rail Phase rail 600 V - 90°C | 2 AWG / 35 mm ² Phase rail Phase rail 600 V - 90°C | 1 AWG / 50 mm ² Phase rail Phase rail 600 V - 90°C | |
| supply terminals -X0: U1/V1/W1/GRD | 3x 895314.0 3x 895314.00010 4x 895314.00040 8-1 AWG / 10-50 mm ² Wago fig. 3, Sht. 11 30 mm | 3x 895314.0 3x 895314.00010 4x 895314.00040 8-1 AWG / 10-50 mm ² Wago fig. 3, Sht. 11 30 mm | 3x 894385.0 3x 894385.00010 4x 894385.00040 4-4/0 AWG / 25-95 mm ² Wago fig. 3, Sht. 11 36 mm | Date 14.12.2020 |
| supply Handling Stripped length X connection | fig. 2, Sht. 12 | fig. 2, Sht. 12 | fig. 2, Sht. 12 | Date M.Zeeh Released M.Zeeh |
| | | | | Name |
| | | | | Date |
| | | | | C Change |

| model | performance-related components | | | | page 10 28 Sht |
|---|--|--|--|--|---|
| | 5 hp BB (4 kW) | 7,5 hp BB+ CB+DB (5,5 kW) | 10 hp BB+ CB+DB (7,5 kW) | 15 hp BB+ CB+DB (11 kW) | |
| machine power supply | 230 V ±10 %, 60 Hz | 230 V ±10 %, 60 Hz | 230 V ±10 %, 60 Hz | 230 V ±10 %, 60 Hz | = + UXB-STC-U3020.06 |
| overload relay -B21 Siemens | 7.8741.00070 3RB3026-1QB0 6-25 A / S0 setting: 6,9 A NEC 430.32(C) incremental setting: 7,7 A | 7.8741.00070 3RB3026-1QB0 6-25 A / S0 setting: 9,9 A NEC 430.32(C) incremental setting: 11,1 A | 7.8741.00070 3RB3026-1QB0 6-25 A / S0 setting: 13,2 A NEC 430.32(C) incremental setting: 14,8 A | 7.8741.00080 3RB3026-1VB0 10-40 A / S0 setting: 20,3 A NEC 430.32(C) incremental setting: 22,8 A | |
| overload relay soundproofing casing -B24 Siemens | 7.8741.00030 3RB3016-1PB0 1,00-4,00 A / S00 setting: 1,43 A NEC 430.32(C) incremental setting: 1,61 A | 7.8741.00030 3RB3016-1PB0 1,00-4,00 A / S00 setting: 1,43 A NEC 430.32(C) incremental setting: 1,61 A | 7.8741.00030 3RB3016-1PB0 1,00-4,00 A / S00 setting: 1,43 A NEC 430.32(C) incremental setting: 1,61 A | 7.8741.00030 3RB3016-1PB0 1,00-4,00 A / S00 setting: 1,43 A NEC 430.32(C) incremental setting: 1,61 A | electrical component parts list 230V BB+CB+DB performance-related components |
| Blower motor -M1 Siemens | 894989.0 230V-DD/60 Hz | 894990.0 230V-DD/60 Hz | 894991.0 230V-DD/60 Hz | 894992.0 230V-DD/60 Hz | |
| vent motor soundproofing casing -M4 ebm | 895260.00010 W2D250 115 V/60 Hz (1PH/N/GRD) 175W 1,55 A | 895260.00010 W2D250 115 V/60 Hz (1PH/N/GRD) 175W 1,55 A | 895260.00010 W2D250 115 V/60 Hz (1PH/N/GRD) 175W 1,55 A | 895260.00010 W2D250 115 V/60 Hz (1PH/N/GRD) 175W 1,55 A | KAESER KOMPRESSOREN |
| contactor -Q1 / -Q2 | 7.8740.00350 3RT2024-1AK60 | 7.8740.00370 3RT2026-1AK60 | 7.8740.00370 3RT2026-1AK60 | 7.8740.00390 3RT2028-1AK60 | |
| auxiliary switch auxiliary switch interference suppressor terminal Phase rail Siemens | 7.8740.05140 3RT2926-1CC00 7.3140.05080 3RV2925-5EB 7.6861.0 3RV1915-1AB | 7.8740.05140 3RT2926-1CC00 7.3140.05080 3RV2925-5EB 7.6861.0 3RV1915-1AB | 7.8740.05140 3RT2926-1CC00 7.3140.05080 3RV2925-5EB 7.6861.0 3RV1915-1AB | 7.8740.05140 3RT2926-1CC00 7.3140.05080 3RV2925-5EB 7.6861.0 3RV1915-1AB | |
| contactor auxiliary switch auxiliary switch interference suppressor wye bridge Siemens | 7.8740.00310 3RT2016-1AK61 7.8740.05010 3RH2911-1HA11 7.8740.05130 3RT2916-1CC00 7.3140.05030 3RT1916-4BA31 | 7.8740.00310 3RT2016-1AK61 7.8740.05010 3RH2911-1HA11 7.8740.05130 3RT2916-1CC00 7.3140.05030 3RT1916-4BA31 | 7.8740.00330 3RT2018-1AK61 7.8740.05010 3RH2911-1HA11 7.8740.05130 3RT2916-1CC00 7.3140.05030 3RT1916-4BA31 | 7.8740.00380 3RT2027-1AK60 7.8740.05140 3RT2926-1CC00 7.3140.02070 3RT1926-4BA31 | |
| motor cable -W19.1/19.2 | 4x14 AWG / 4G2,5 mm ² 600 V - 90°C | 4x14 AWG / 4G2,5 mm ² 600 V - 90°C | 4x12 AWG / 4G4 mm ² 600 V - 90°C | 4x10 AWG / 4G6 mm ² 600 V - 90°C | |
| connection -W11 -W13 -W14 | 10 AWG / 6 mm ² Phase rail 14 AWG / 2,5 mm ² 600 V - 90°C | 10 AWG / 6 mm ² Phase rail 14 AWG / 2,5 mm ² 600 V - 90°C | 8 AWG / 10 mm ² Phase rail 14 AWG / 2,5 mm ² 600 V - 90°C | 8 AWG / 10 mm ² Phase rail Phase rail 14 AWG / 2,5 mm ² 600 V - 90°C | |
| supply terminals -X0: U1/V1/W1/GRD | 894864.00010 14-4 AWG / 2,5-16 mm ² Wieland fig. 2, Sht. 11 16 mm fig. 1, Sht. 12 | 894864.00010 14-4 AWG / 2,5-16 mm ² Wieland fig. 2, Sht. 11 16 mm fig. 1, Sht. 12 | 894864.00010 14-4 AWG / 2,5-16 mm ² Wieland fig. 2, Sht. 11 16 mm fig. 1, Sht. 12 | 894864.00010 14-4 AWG / 2,5-16 mm ² Wieland fig. 2, Sht. 11 16 mm fig. 1, Sht. 12 | Date 14.12.2020 Drawn M.Zeesh Released M.Zeesh Name Date C Change |
| supply Handling Stripped length X connection | | | | | |

| model | performance-related components | | | | | page 11 28 Sht |
|---|--|--|--|--|--|--|
| | 20 hp BB+ CB+DB (15 kW) | 25 hp CB+ DB (18,5 kW) | 30 hp CB+ DB (22 kW) | 40 hp CB (30 kW) | 40 hp DB (30 kW) | |
| machine power supply | 230 V ±10 %, 60 Hz | 230 V ±10 %, 60 Hz | 230 V ±10 %, 60 Hz | 230 V ±10 %, 60 Hz | 230 V ±10 %, 60 Hz | = + UXB-STC-U3020.06 |
| overload relay -B21 Siemens | 7.8741.00090 3RB3036-1UB0 12,5-50 A / S2 setting: 27,7 A NEC 430.32(C) incremental setting: 31 A | 7.8741.00090 3RB3036-1UB0 12,5-50 A / S2 setting: 32,4 A NEC 430.32(C) incremental setting: 36,3 A | 7.8741.00100 3RB3036-1WB0 20-80 A / S2 setting: 38,1 A NEC 430.32(C) incremental setting: 42,7 A | 7.8741.00140 3RB3046-1EB0 32-115 A / S3 setting: 54,3 A NEC 430.32(C) incremental setting: 60,8 A | 7.8741.00140 3RB3046-1EB0 32-115 A / S3 setting: 54,3 A NEC 430.32(C) incremental setting: 60,8 A | |
| overload relay soundproofing casing -B24 Siemens | 7.8741.00030 3RB3016-1PB0 1,00-4,00 A / S00 setting: 1,43 A NEC 430.32(C) incremental setting: 1,61 A | 7.8741.00030 3RB3016-1PB0 1,00-4,00 A / S00 setting: 1,43 A NEC 430.32(C) incremental setting: 1,61 A | 7.8741.00030 3RB3016-1PB0 1,00-4,00 A / S00 setting: 1,43 A NEC 430.32(C) incremental setting: 1,61 A | 7.8741.00030 3RB3016-1PB0 1,00-4,00 A / S00 setting: 1,43 A NEC 430.32(C) incremental setting: 1,61 A | 7.8741.00030 3RB3016-1PB0 1,00-4,00 A / S00 setting: 1,43 A NEC 430.32(C) incremental setting: 1,61 A | |
| Blower motor -M1 Siemens | 895049.0 230V-DD/60 Hz | 894994.0 230V-DD/60 Hz | 894995.0 230V-DD/60 Hz | 894996.1 (CB) 230V-DD/60 Hz | 894997.1 (DB) 230V-DD/60 Hz | electrical component parts list 230V BB+CB+DB performance-related components |
| vent motor soundproofing casing -M4 ebm | 895260.00010 W2D250 115 V/60 Hz (1PH/N/GRD) 175W 1,55 A | 895260.00010 W2D250 115 V/60 Hz (1PH/N/GRD) 175W 1,55 A | 895260.00010 W2D250 115 V/60 Hz (1PH/N/GRD) 175W 1,55 A | 895260.00010 W2D250 115 V/60 Hz (1PH/N/GRD) 175W 1,55 A | 895260.00010 W2D250 115 V/60 Hz (1PH/N/GRD) 175W 1,55 A | |
| contactor -Q1 / -Q2 | 7.8740.00410 3RT2036-1AK60 | 7.8740.00400 3RT2035-1AK60 | 7.8740.00430 3RT2038-1AK60 | 7.8740.00440 3RT2045-1AK60 | 7.8740.00440 3RT2045-1AK60 | KAESER KOMPRESSOREN |
| auxiliary switch | . | . | . | . | . | |
| auxiliary switch | . | . | . | . | . | |
| interference suppressor | 7.8740.05150 3RT2936-1CC00 | 7.8740.05150 3RT2936-1CC00 | 7.8740.05150 3RT2936-1CC00 | 7.8740.05170 3RT2946-1CC00 | 7.8740.05170 3RT2946-1CC00 | |
| terminal | 7.3140.05070 3RV2935-5E | 7.3140.05070 3RV2935-5E | 7.3140.05070 3RV2935-5E | 3x 7.3140.02100 3x 3RA1943-3L | 3x 7.3140.02100 3x 3RA1943-3L | |
| Phase rail | 7.3140.05270 3RA2933-3FA00 | 7.3140.05270 3RA2933-3FA00 | 7.3140.05270 3RA2933-3FA00 | 7.3140.05370 3RA2943-3FA00 | 7.3140.05370 3RA2943-3FA00 | |
| contactor -Q3 | 7.8740.00400 3RT2035-1AK60 | 7.8740.00400 3RT2035-1AK60 | 7.8740.00400 3RT2035-1AK60 | 7.8740.00400 3RT2035-1AK60 | 7.8740.00400 3RT2035-1AK60 | |
| auxiliary switch | . | . | . | . | . | |
| auxiliary switch | . | . | . | . | . | |
| interference suppressor | 7.8740.05150 3RT2936-1CC00 | 7.8740.05150 3RT2936-1CC00 | 7.8740.05150 3RT2936-1CC00 | 7.8740.05150 3RT2936-1CC00 | 7.8740.05150 3RT2936-1CC00 | |
| wye bridge | 7.3140.01170 3RT1936-4BA31 | 7.3140.01170 3RT1936-4BA31 | 7.3140.01170 3RT1936-4BA31 | 7.3140.01170 3RT1936-4BA31 | 7.3140.01170 3RT1936-4BA31 | |
| motor cable -W19.1/19.2 | 4x8 AWG / 4G10 mm ² 600 V - 90°C | 4x6 AWG / 4G16 mm ² 600 V - 90°C | 4x6 AWG / 4G16 mm ² 600 V - 90°C | 4x4 AWG / 4G25 mm ² 600 V - 90°C | 4x4 AWG / 4G25 mm ² 600 V - 90°C | |
| connection -W11 -W13 -W14 | 6 AWG / 16 mm ² Phase rail Phase rail 600 V - 90°C | 4 AWG / 25 mm ² Phase rail Phase rail 600 V - 90°C | 2 AWG / 35 mm ² Phase rail Phase rail 600 V - 90°C | 1 AWG / 50 mm ² 4 AWG / 25 mm ² 8 AWG / 10 mm ² 600 V - 90°C | 1 AWG / 50 mm ² 4 AWG / 25 mm ² 8 AWG / 10 mm ² 600 V - 90°C | |
| supply terminals U1/V1/W1/GRD | 3x 895314.0 3x 895314.00010 4x 895314.00040 8-1 AWG / 10-50 mm ² Wago fig. 3, Sht. 11 30 mm | 3x 895314.0 3x 895314.00010 4x 895314.00040 8-1 AWG / 10-50 mm ² Wago fig. 3, Sht. 11 30 mm | 3x 895314.0 3x 895314.00010 4x 895314.00040 8-1 AWG / 10-50 mm ² Wago fig. 3, Sht. 11 30 mm | 3x 894385.0 3x 894385.00010 4x 894385.00040 4-4/0 AWG / 25-95 mm ² Wago fig. 3, Sht. 11 36 mm | 3x 894385.0 3x 894385.00010 4x 894385.00040 4-4/0 AWG / 25-95 mm ² Wago fig. 3, Sht. 11 36 mm | |
| supply Handling Stripped length X connection | fig. 2, Sht. 12 | fig. 2, Sht. 12 | fig. 2, Sht. 12 | fig. 2, Sht. 12 | fig. 2, Sht. 12 | |
| | | | | | | Date 14.12.2020 |
| | | | | | | Drawn M.Zeesh |
| | | | | | | Released M.Zeesh |
| | | | | | | Name |
| | | | | | | Date |
| | | | | | | C Change |

| model | performance-related components | | | = | + | page 12 28 Sht |
|--|--|--|--|---|---|--|
| | 25 hp EB (18,5 kW) | 30 hp EB (22 kW) | 40 hp EB (30 kW) | | | |
| machine power supply | 230 V ±10 %, 60 Hz | 230 V ±10 %, 60 Hz | 230 V ±10 %, 60 Hz | | | UXB-STC-U3020.06 |
| overload relay -B21 Siemens | 7.8741.00090 3RB3036-1UB0 12,5-50 A / S2 setting: 32,4 A NEC 430.32(C) incremental setting: 36,3 A | 7.8741.00100 3RB3036-1WB0 20-80 A / S2 setting: 38,1 A NEC 430.32(C) incremental setting: 42,7 A | 7.8741.00140 3RB3046-1EB0 32-115 A / S3 setting: 54,3 A NEC 430.32(C) incremental setting: 60,8 A | | | |
| overload relay soundproofing casing -B24 Siemens | 7.8741.00030 3RB3016-1PB0 1,00-4,00 A / S00 setting: 1,01 A NEC 430.32(C) incremental setting: 1,14 A | 7.8741.00030 3RB3016-1PB0 1,00-4,00 A / S00 setting: 1,01 A NEC 430.32(C) incremental setting: 1,14 A | 7.8741.00030 3RB3016-1PB0 1,00-4,00 A / S00 setting: 1,01 A NEC 430.32(C) incremental setting: 1,14 A | | | |
| Blower motor -M1 Siemens | 894994.0 230V-DD/60 Hz | 894995.0 230V-DD/60 Hz | 894997.1 230V-DD/60 Hz | | | electrical component parts list 230V EB performance-related components |
| vent motor soundproofing casing -M4 Sodeca | 895040.00040 HC-31-2T / H-I-E 230 V-D/60 Hz (3PH/GRD) 210W 1,10 A | 895040.00040 HC-31-2T / H-I-E 230 V-D/60 Hz (3PH/GRD) 210W 1,10 A | 895040.00040 HC-31-2T / H-I-E 230 V-D/60 Hz (3PH/GRD) 210W 1,10 A | | | |
| contactor -Q1 / -Q2 | 7.8740.00400 3RT2035-1AK60 | 7.8740.00430 3RT2038-1AK60 | 7.8740.00440 3RT2045-1AK60 | | | KAESER KOMPRESSOREN |
| auxiliary switch . | 7.8740.05030 3RH2911-1HA20 | 7.8740.05030 3RH2911-1HA20 | | | | |
| auxiliary switch . | | | | | | |
| interference suppressor . | 7.8740.05150 3RT2936-1CC00 | 7.8740.05150 3RT2936-1CC00 | 7.8740.05170 3RT2946-1CC00 | | | |
| terminal . | 7.3140.05070 3RV2935-5E | 7.3140.05070 3RV2935-5E | 3x 7.3140.02100 3x 3RA1943-3L | | | |
| Phase rail . | 7.3140.05270 3RA2933-3FA00 | 7.3140.05270 3RA2933-3FA00 | 7.3140.05370 3RA2943-3FA00 | | | |
| contactor -Q3 | 7.8740.00400 3RT2035-1AK60 | 7.8740.00400 3RT2035-1AK60 | 7.8740.00410 3RT2036-1AK60 | | | |
| auxiliary switch . | | | | | | |
| auxiliary switch . | | | | | | |
| interference suppressor . | 7.8740.05150 3RT2936-1CC00 | 7.8740.05150 3RT2936-1CC00 | 7.8740.05150 3RT2936-1CC00 | | | |
| wye bridge . | 7.3140.01170 3RT1936-4BA31 | 7.3140.01170 3RT1936-4BA31 | 7.3140.01170 3RT1936-4BA31 | | | |
| motor cable -W19.1/19.2 | 4x6 AWG / 4G16 mm ² 600 V - 90°C | 4x6 AWG / 4G16 mm ² 600 V - 90°C | 4x4 AWG / 4G25 mm ² 600 V - 90°C | | | |
| connection -W11 Phase rail -W13 Phase rail -W14 Phase rail | 4 AWG / 25 mm ² 600 V - 90°C | 2 AWG / 35 mm ² 600 V - 90°C | 1 AWG / 50 mm ² 4 AWG / 25 mm ² 8 AWG / 10 mm ² 600 V - 90°C | | | |
| supply terminals -X0: U1/V1/W1/GRD | 3x 895314.0 3x 895314.00010 4x 895314.00040 8-1 AWG / 10-50 mm ² Wago fig. 3, Sht. 11 30 mm | 3x 895314.0 3x 895314.00010 4x 895314.00040 8-1 AWG / 10-50 mm ² Wago fig. 3, Sht. 11 30 mm | 3x 894385.0 3x 894385.00010 4x 894385.00040 4-4/0 AWG / 25-95 mm ² Wago fig. 3, Sht. 11 36 mm | | | Date 14.12.2020 Drawn M.Zeeh Released M.Zeeh |
| supply Handling Stripped length X connection | fig. 2, Sht. 12 | fig. 2, Sht. 12 | fig. 2, Sht. 12 | | | Name Date C Change |

| model | performance-related components | | | | | page 13 28 Sht |
|--|--|--|--|--|--|----------------------|
| | 5 hp BB (4 kW) | 7,5 hp BB+ CB+DB (5,5 kW) | 10 hp BB+ CB+DB (7,5 kW) | 15 hp BB+ CB+DB (11 kW) | 20 hp BB+ CB+DB (15 kW) | |
| machine power supply | 460 V ±10 %, 60 Hz | 460 V ±10 %, 60 Hz | 460 V ±10 %, 60 Hz | 460 V ±10 %, 60 Hz | 460 V ±10 %, 60 Hz | UXB-STC-U3020.06 |
| overload relay -B21 Siemens | 7.8741.00060 3RB3026-1SB0 3-12 A / S0 setting: 3,4 A NEC 430.32(C) incremental setting: 3,8 A | 7.8741.00060 3RB3026-1SB0 3-12 A / S0 setting: 5 A NEC 430.32(C) incremental setting: 5,6 A | 7.8741.00060 3RB3026-1SB0 3-12 A / S0 setting: 6,6 A NEC 430.32(C) incremental setting: 7,4 A | 7.8741.00070 3RB3026-1QB0 6-25 A / S0 setting: 10,2 A NEC 430.32(C) incremental setting: 11,4 A | 7.8741.00070 3RB3026-1QB0 6-25 A / S0 setting: 13,9 A NEC 430.32(C) incremental setting: 15,5 A | |
| overload relay soundproofing casing -B24 Siemens | 7.8741.00030 3RB3016-1PB0 1,00-4,00 A / S00 setting: 1,43 A NEC 430.32(C) incremental setting: 1,61 A | 7.8741.00030 3RB3016-1PB0 1,00-4,00 A / S00 setting: 1,43 A NEC 430.32(C) incremental setting: 1,61 A | 7.8741.00030 3RB3016-1PB0 1,00-4,00 A / S00 setting: 1,43 A NEC 430.32(C) incremental setting: 1,61 A | 7.8741.00030 3RB3016-1PB0 1,00-4,00 A / S00 setting: 1,43 A NEC 430.32(C) incremental setting: 1,61 A | 7.8741.00030 3RB3016-1PB0 1,00-4,00 A / S00 setting: 1,43 A NEC 430.32(C) incremental setting: 1,61 A | |
| Blower motor -M1 Siemens | 894989.0 460V-D/60 Hz | 894990.0 460V-D/60 Hz | 894991.0 460V-D/60 Hz | 894992.0 460V-D/60 Hz | 895049.0 460V-D/60 Hz | |
| vent motor soundproofing casing -M4 ebm | 895260.00010 W2D250 (1PH/N/GRD) 115 V/60 Hz, 175W 1,55 A | 895260.00010 W2D250 (1PH/N/GRD) 115 V/60 Hz, 175W 1,55 A | 895260.00010 W2D250 (1PH/N/GRD) 115 V/60 Hz, 175W 1,55 A | 895260.00010 W2D250 (1PH/N/GRD) 115 V/60 Hz, 175W 1,55 A | 895260.00010 W2D250 (1PH/N/GRD) 115 V/60 Hz, 175W 1,55 A | |
| contactor auxiliary switch auxiliary switch interference suppressor terminal Phase rail -Q1 / -Q2 Siemens | 7.8740.00340 3RT2023-1AK60 7.8740.05140 3RT2926-1CC00 7.3140.05080 3RV2925-5EB 7.6861.0 3RV1915-1AB | 7.8740.00340 3RT2023-1AK60 7.8740.05140 3RT2926-1CC00 7.3140.05080 3RV2925-5EB 7.6861.0 3RV1915-1AB | 7.8740.00350 3RT2024-1AK60 7.8740.05140 3RT2926-1CC00 7.3140.05080 3RV2925-5EB 7.6861.0 3RV1915-1AB | 7.8740.00370 3RT2026-1AK60 7.8740.05140 3RT2926-1CC00 7.3140.05080 3RV2925-5EB 7.6861.0 3RV1915-1AB | 7.8740.00390 3RT2028-1AK60 7.8740.05140 3RT2926-1CC00 7.3140.05080 3RV2925-5EB 7.6861.0 3RV1915-1AB | |
| contactor auxiliary switch auxiliary switch interference suppressor wye bridge -Q3 Siemens | 7.8740.00310 3RT2016-1AK61 7.8740.05010 3RH2911-1HA11 7.8740.05130 3RT2916-1CC00 7.3140.05030 3RT1916-4BA31 | 7.8740.00310 3RT2016-1AK61 7.8740.05010 3RH2911-1HA11 7.8740.05130 3RT2916-1CC00 7.3140.05030 3RT1916-4BA31 | 7.8740.00310 3RT2016-1AK61 7.8740.05010 3RH2911-1HA11 7.8740.05130 3RT2916-1CC00 7.3140.05030 3RT1916-4BA31 | 7.8740.00330 3RT2018-1AK61 7.8740.05010 3RH2911-1HA11 7.8740.05130 3RT2916-1CC00 7.3140.05030 3RT1916-4BA31 | 7.8740.00370 3RT2026-1AK60 7.8740.05140 3RT2926-1CC00 7.3140.02070 3RT1926-4BA31 | |
| motor cable -W19.1/19.2 | 4x14 AWG / 4G2,5 mm ² 600 V - 90°C | 4x14 AWG / 4G2,5 mm ² 600 V - 90°C | 4x14 AWG / 4G2,5 mm ² 600 V - 90°C | 4x12 AWG / 4G4 mm ² 600 V - 90°C | 4x10 AWG / 4G6 mm ² 600 V - 90°C | |
| connection -W11 -W13 -W14 | 14 AWG / 2,5 mm ² Phase rail 14 AWG / 2,5 mm ² 600 V - 90°C | 14 AWG / 2,5 mm ² Phase rail 14 AWG / 2,5 mm ² 600 V - 90°C | 14 AWG / 2,5 mm ² Phase rail 14 AWG / 2,5 mm ² 600 V - 90°C | 10 AWG / 6 mm ² Phase rail 14 AWG / 2,5 mm ² 600 V - 90°C | 8 AWG / 10 mm ² Phase rail Phase rail 600 V - 90°C | |
| supply terminals -X0: U1/V1/W1/GRD Handling Stripped length X connection | 894864.00010 14-4 AWG / 2,5-16 mm ² Wieland fig. 2, Sht. 11 16 mm fig. 1, Sht. 12 | 894864.00010 14-4 AWG / 2,5-16 mm ² Wieland fig. 2, Sht. 11 16 mm fig. 1, Sht. 12 | 894864.00010 14-4 AWG / 2,5-16 mm ² Wieland fig. 2, Sht. 11 16 mm fig. 1, Sht. 12 | 894864.00010 14-4 AWG / 2,5-16 mm ² Wieland fig. 2, Sht. 11 16 mm fig. 1, Sht. 12 | 894864.00010 14-4 AWG / 2,5-16 mm ² Wieland fig. 2, Sht. 11 16 mm fig. 1, Sht. 12 | |

electrical component parts list
460V BB+CB+DB
performance-related components



| | | |
|---|----------|------------|
| c | Date | 14.12.2020 |
| b | Drawn | M.Zeesh |
| a | Released | M.Zeesh |
| C | Change | |
| | Name | |
| | Date | |

| model | performance-related components | | | | | page 14 28 Sht |
|--|--|---|---|---|---|---|
| | 25 hp CB+ DB (18,5 kW) | 30 hp CB+ DB (22 kW) | 40 hp CB+ DB (30 kW) | 50 hp DB (37 kW) | 60 hp DB (45 kW) | |
| machine power supply | 460 V ±10 %, 60 Hz | 460 V ±10 %, 60 Hz | 460 V ±10 %, 60 Hz | 460 V ±10 %, 60 Hz | 460 V ±10 %, 60 Hz | = + UXB-STC-U3020.06 |
| overload relay -B21 Siemens | 7.8741.00080 3RB3026-1VB0 10-40 A / S0 setting: 16,2 A NEC 430.32(C) incremental setting: 18,2 A | 7.8741.00090 3RB3036-1UB0 12,5-50 A / S2 setting: 19,1 A NEC 430.32(C) incremental setting: 21,3 A | 7.8741.00090 3RB3036-1UB0 12,5-50 A / S2 setting: 27,1 A NEC 430.32(C) incremental setting: 30,4 A | 7.8741.00090 3RB3036-1UB0 12,5-50 A / S2 setting: 32,9 A NEC 430.32(C) incremental setting: 36,9 A | 7.8741.00100 3RB3036-1WB0 20-80 A / S2 setting: 40,4 A NEC 430.32(C) incremental setting: 45,3 A | |
| overload relay soundproofing casing -B24 Siemens | 7.8741.00030 3RB3016-1PB0 1,00-4,00 A / S00 setting: 1,43 A NEC 430.32(C) incremental setting: 1,61 A | 7.8741.00030 3RB3016-1PB0 1,00-4,00 A / S00 setting: 1,43 A NEC 430.32(C) incremental setting: 1,61 A | 7.8741.00030 3RB3016-1PB0 1,00-4,00 A / S00 setting: 1,43 A NEC 430.32(C) incremental setting: 1,61 A | 7.8741.00030 3RB3016-1PB0 1,00-4,00 A / S00 setting: 1,43 A NEC 430.32(C) incremental setting: 1,61 A | 7.8741.00030 3RB3016-1PB0 1,00-4,00 A / S00 setting: 1,43 A NEC 430.32(C) incremental setting: 1,61 A | |
| Blower motor -M1 Siemens | 894994.0 460 V-D/60 Hz | 894995.0 460 V-D/60 Hz | 894996.1 (CB) 894997.1 (DB) 460 V-D/60 Hz | 894978.1 460 V-D/60 Hz | 894979.1 460 V-D/60 Hz | electrical component parts list 460V CB+DB performance-related components |
| vent motor soundproofing casing -M4 ebm | 895260.00010 W2D250 (1PH/N/GRD) 115 V/60 Hz, 175W 1,55 A | 895260.00010 W2D250 (1PH/N/GRD) 115 V/60 Hz, 175W 1,55 A | 895260.00010 W2D250 (1PH/N/GRD) 115 V/60 Hz, 175W 1,55 A | 895260.00010 W2D250 (1PH/N/GRD) 115 V/60 Hz, 175W 1,55 A | 895260.00010 W2D250 (1PH/N/GRD) 115 V/60 Hz, 175W 1,55 A | |
| contactor auxiliary switch auxiliary switch interference suppressor terminal Phase rail -Q1 / -Q2 Siemens | 7.8740.00380 3RT2027-1AK60 7.8740.05140 3RT2926-1CC00 7.3140.05080 3RV2925-5EB 7.6861.0 3RV1915-1AB | 7.8740.00400 3RT2035-1AK60 7.8740.05150 3RT2936-1CC00 7.3140.05070 3RV2935-5E 7.3140.05270 3RA2933-3FA00 | 7.8740.00400 3RT2035-1AK60 7.8740.05150 3RT2936-1CC00 7.3140.05070 3RV2935-5E 7.3140.05270 3RA2933-3FA00 | 7.8740.00410 3RT2036-1AK60 7.8740.05150 3RT2936-1CC00 7.3140.05070 3RV2935-5E 7.3140.05270 3RA2933-3FA00 | 7.8740.00430 3RT2038-1AK60 7.8740.05150 3RT2936-1CC00 7.3140.05070 3RV2935-5E 7.3140.05270 3RA2933-3FA00 | |
| contactor auxiliary switch auxiliary switch interference suppressor we bridge -Q3 Siemens | 7.8740.00370 3RT2026-1AK60 7.8740.05140 3RT2926-1CC00 7.3140.02070 3RT1926-4BA31 | 7.8740.00370 3RT2026-1AK60 7.8740.05140 3RT2926-1CC00 7.3140.02070 3RT1926-4BA31 | 7.8740.00380 3RT2027-1AK60 7.8740.05140 3RT2926-1CC00 7.3140.02070 3RT1926-4BA31 | 7.8740.00400 3RT2035-1AK60 7.8740.05150 3RT2936-1CC00 7.3140.01170 3RT1936-4BA31 | 7.8740.00400 3RT2035-1AK60 7.8740.05150 3RT2936-1CC00 7.3140.01170 3RT1936-4BA31 | |
| motor cable -W19.1/19.2 | 4x10 AWG / 4G6 mm ² 600 V - 90°C | 4x10 AWG / 4G6 mm ² 600 V - 90°C | 4x8 AWG / 4G10 mm ² 600 V - 90°C | 4x6 AWG / 4G16 mm ² 600 V - 90°C | 4x6 AWG / 4G16 mm ² 600 V - 90°C | |
| connection -W11 Phase rail -W13 Phase rail -W14 600 V - 90°C | 8 AWG / 10 mm2 Phase rail 14 AWG / 2,5 mm2 600 V - 90°C | 8 AWG / 10 mm2 Phase rail 14 AWG / 2,5 mm2 600 V - 90°C | 6 AWG / 16 mm2 Phase rail 10 AWG / 6 mm2 600 V - 90°C | 4 AWG / 25 mm2 Phase rail Phase rail 600 V - 90°C | 2 AWG / 35 mm2 Phase rail Phase rail 600 V - 90°C | |
| supply terminals U1/V1/W1/GRD Handling Stripped length X connection supply | 894864.00010 14-4 AWG / 2,5-16 mm ² Wieland fig. 2, Sht. 11 16 mm fig. 1, Sht. 12 | 894864.00010 14-4 AWG / 2,5-16 mm ² Wieland fig. 2, Sht. 11 16 mm fig. 1, Sht. 12 | 3x 895314.0 3x 895314.00010 4x 895314.00040 8-1 AWG / 10-50 mm ² Wago fig. 3, Sht. 11 30 mm fig. 2, Sht. 12 | 3x 895314.0 3x 895314.00010 4x 895314.00040 8-1 AWG / 10-50 mm ² Wago fig. 3, Sht. 11 30 mm fig. 2, Sht. 12 | 3x 895314.0 3x 895314.00010 4x 895314.00040 8-1 AWG / 10-50 mm ² Wago fig. 3, Sht. 11 30 mm fig. 2, Sht. 12 | Date 14.12.2020 Drawn M.Zeeh Released M.Zeeh Name Date C Change |

| model | performance-related components | | | | page 15 28 Sht |
|---|--|--|---|---|-------------------------|
| | 25 hp EB (18,5 kW) | 30 hp EB (22 kW) | 40 hp EB+ FB-C (30 kW) | 40 hp FB-S (30 kW) | |
| machine power supply | 460 V ±10 %, 60 Hz | 460 V ±10 %, 60 Hz | 460 V ±10 %, 60 Hz | 460 V ±10 %, 60 Hz | = + UXB-STC-U3020.06 |
| overload relay -B21 Siemens | 7.8741.00080 3RB3026-1VB0 10-40 A / S0 setting: 16,2 A NEC 430.32(C) incremental setting: 18,2 A | 7.8741.00090 3RB3036-1UB0 12,5-50 A / S2 setting: 19,1 A NEC 430.32(C) incremental setting: 21,3 A | 7.8741.00090 3RB3036-1UB0 12,5-50 A / S2 setting: 27,1 A NEC 430.32(C) incremental setting: 30,4 A | 7.8741.00090 3RB3036-1UB0 12,5-50 A / S2 setting: 27,1 A NEC 430.32(C) incremental setting: 30,4 A | |
| overload relay soundproofing casing -B24 Siemens | 7.8741.00020 3RB3016-1NB0 0,32-1,25 A / S00 setting: 0,57 A NEC 430.32(C) incremental setting: 0,64 A | 7.8741.00020 3RB3016-1NB0 0,32-1,25 A / S00 setting: 0,57 A NEC 430.32(C) incremental setting: 0,64 A | 7.8741.00020 3RB3016-1NB0 0,32-1,25 A / S00 setting: 0,57 A NEC 430.32(C) incremental setting: 0,64 A | 7.8741.00020 3RB3016-1NB0 0,32-1,25 A / S00 setting: 0,57 A NEC 430.32(C) incremental setting: 0,64 A | |
| Blower motor -M1 Siemens | 894994.0 460V-D/60 Hz | 894995.0 460V-D/60 Hz | 894997.1 460V-D/60 Hz | 894997.1 460V-D/60 Hz | |
| vent motor soundproofing casing -M4 Sodeca/ebm | 895040.00040 HC-31-2T / H-I-E 460 V-Y/60 Hz 210W 0,62 A | 895040.00040 HC-31-2T / H-I-E 460 V-Y/60 Hz 210W 0,62 A | 895040.00040 HC-31-2T / H-I-E 460 V-Y/60 Hz 210W 0,62 A | 895426.0 W4D420 (ebm) 460 V-Y/60 Hz 265W 0,62 A | |
| contactor -Q1 / -Q2 | 7.8740.00380 3RT2027-1AK60 | 7.8740.00400 3RT2035-1AK60 | 7.8740.00400 3RT2035-1AK60 | 7.8740.00400 3RT2035-1AK60 | |
| auxiliary switch | 7.8740.05030 3RH2911-1HA20 | 7.8740.05030 3RH2911-1HA20 | 7.8740.05030 3RH2911-1HA20 | 7.8740.05030 3RH2911-1HA20 | |
| auxiliary switch | . | . | . | . | |
| interference suppressor | 7.8740.05140 3RT2926-1CC00 | 7.8740.05150 3RT2936-1CC00 | 7.8740.05150 3RT2936-1CC00 | 7.8740.05150 3RT2936-1CC00 | |
| terminal | 7.3140.05080 3RV2925-5EB | 7.3140.05070 3RV2935-5E | 7.3140.05070 3RV2935-5E | 7.3140.05070 3RV2935-5E | |
| Phase rail | 7.6861.0 3RV1915-1AB | 7.3140.05270 3RA2933-3FA00 | 7.3140.05270 3RA2933-3FA00 | 7.3140.05270 3RA2933-3FA00 | |
| contactor -Q3 | 7.8740.00370 3RT2026-1AK60 | 7.8740.00380 3RT2027-1AK60 | 7.8740.00400 3RT2035-1AK60 | 7.8740.00400 3RT2035-1AK60 | |
| auxiliary switch | . | . | . | . | |
| auxiliary switch | . | . | . | . | |
| interference suppressor | 7.8740.05140 3RT2926-1CC00 | 7.8740.05140 3RT2926-1CC00 | 7.8740.05150 3RT2936-1CC00 | 7.8740.05150 3RT2936-1CC00 | |
| wye bridge | 7.3140.02070 3RT1926-4BA31 | 7.3140.02070 3RT1926-4BA31 | 7.3140.01170 3RT1936-4BA31 | 7.3140.01170 3RT1936-4BA31 | |
| motor cable -W19.1/19.2 | 4x10 AWG / 4G6 mm ² 600 V - 90°C | 4x10 AWG / 4G6 mm ² 600 V - 90°C | 4x8 AWWG / 4G10 mm ² 600 V - 90°C | 4x8 AWWG / 4G10 mm ² 600 V - 90°C | |
| connection -W11 -W13 -W14 | 8 AWG / 10 mm2 Phase rail Phase rail 600 V - 90°C | 8 AWG / 10 mm2 Phase rail 14 AWG / 2,5 mm2 600 V - 90°C | 6 AWG / 16 mm2 Phase rail Phase rail 600 V - 90°C | 6 AWG / 16 mm2 Phase rail Phase rail 600 V - 90°C | |
| supply terminals -X0: U1/V1/W1/GRD | 894864.00010 14-4 AWG / 2,5-16 mm ² Wieland fig. 2, Sht. 11 16 mm fig. 1, Sht. 12 | 894864.00010 14-4 AWG / 2,5-16 mm ² Wieland fig. 2, Sht. 11 16 mm fig. 1, Sht. 12 | 3x 895314.0 3x 895314.00010 4x 895314.00040 8-1 AWG / 10-50 mm ² Wago fig. 3, Sht. 11 30 mm fig. 2, Sht. 12 | 3x 895314.0 3x 895314.00010 4x 895314.00040 8-1 AWG / 10-50 mm ² Wago fig. 3, Sht. 11 30 mm fig. 2, Sht. 12 | |
| supply | Handling Stripped length X connection | | | | |

| | | | | | |
|---------------------------------|--|------------|------------|--------------------------------|--|
| electrical component parts list | | 460V EB+FB | | performance-related components | |
| KAESER KOMPRESSOREN | | Date | 14.12.2020 | Name | |
| c | | Drawn | M.Zeesh | | |
| b | | Released | M.Zeesh | | |
| a | | | | | |
| C Change | | | | | |

| model | performance-related components | | | | page 16 28 Sht |
|--|--|--|--|--|-------------------------|
| | 50 hp EB+ FB-C (37 kW) | 50 hp FB-S (37 kW) | 60 hp EB+ FB-C (45 kW) | 60 hp FB-S (45 kW) | |
| machine power supply | 460 V ±10 %, 60 Hz | 460 V ±10 %, 60 Hz | 460 V ±10 %, 60 Hz | 460 V ±10 %, 60 Hz | = + UXB-STC-U3020.06 |
| overload relay -B21 Siemens | 7.8741.00090 3RB3036-1UB0 12.5-50 A / S2 setting: 32,9 A NEC 430.32(C) incremental setting: 36,9 A | 7.8741.00090 3RB3036-1UB0 12.5-50 A / S2 setting: 32,9 A NEC 430.32(C) incremental setting: 36,9 A | 7.8741.00100 3RB3036-1WB0 20-80 A / S2 setting: 40,4 A NEC 430.32(C) incremental setting: 45,3 A | 7.8741.00100 3RB3036-1WB0 20-80 A / S2 setting: 40,4 A NEC 430.32(C) incremental setting: 45,3 A | |
| overload relay soundproofing casing -B24 Siemens | 7.8741.00020 3RB3016-1NB0 0,32-1,25 A / S00 setting: 0,57 A NEC 430.32(C) incremental setting: 0,64 A | 7.8741.00020 3RB3016-1NB0 0,32-1,25 A / S00 setting: 0,57 A NEC 430.32(C) incremental setting: 0,64 A | 7.8741.00020 3RB3016-1NB0 0,32-1,25 A / S00 setting: 0,57 A NEC 430.32(C) incremental setting: 0,64 A | 7.8741.00020 3RB3016-1NB0 0,32-1,25 A / S00 setting: 0,57 A NEC 430.32(C) incremental setting: 0,64 A | |
| Blower motor -M1 Siemens | 894978.1 460V-D/60 Hz | 894978.1 460V-D/60 Hz | 894979.1 460V-D/60 Hz | 894979.1 460V-D/60 Hz | |
| vent motor soundproofing casing -M4 Sodeca/ebm | 895040.00040 HC-31-2T / H-I-E 460 V-Y/60 Hz 210W 0,62 A | 895426.0 W4D420 (ebm) 460 V-Y/60 Hz 265W 0,62 A | 895040.00040 HC-31-2T / H-I-E 460 V-Y/60 Hz 210W 0,62 A | 895426.0 W4D420 (ebm) 460 V-Y/60 Hz 265W 0,62 A | |
| contactor -Q1 / -Q2 | 7.8740.00410 3RT2036-1AK60 | 7.8740.00410 3RT2036-1AK60 | 7.8740.00430 3RT2038-1AK60 | 7.8740.00430 3RT2038-1AK60 | |
| auxiliary switch | 7.8740.05030 3RH2911-1HA20 | 7.8740.05030 3RH2911-1HA20 | 7.8740.05030 3RH2911-1HA20 | 7.8740.05030 3RH2911-1HA20 | |
| auxiliary switch | . | . | . | . | |
| interference suppressor | 7.8740.05150 3RT2936-1CC00 | 7.8740.05150 3RT2936-1CC00 | 7.8740.05150 3RT2936-1CC00 | 7.8740.05150 3RT2936-1CC00 | |
| terminal | 7.3140.05070 3RV2935-5E | 7.3140.05070 3RV2935-5E | 7.3140.05070 3RV2935-5E | 7.3140.05070 3RV2935-5E | |
| Phase rail | 7.3140.05270 3RA2933-3FA00 | 7.3140.05270 3RA2933-3FA00 | 7.3140.05270 3RA2933-3FA00 | 7.3140.05270 3RA2933-3FA00 | |
| contactor -Q3 | 7.8740.00400 3RT2035-1AK60 | 7.8740.00400 3RT2035-1AK60 | 7.8740.00400 3RT2035-1AK60 | 7.8740.00400 3RT2035-1AK60 | |
| auxiliary switch | . | . | . | . | |
| auxiliary switch | . | . | . | . | |
| interference suppressor | 7.8740.05150 3RT2936-1CC00 | 7.8740.05150 3RT2936-1CC00 | 7.8740.05150 3RT2936-1CC00 | 7.8740.05150 3RT2936-1CC00 | |
| wye bridge | 7.3140.01170 3RT1936-4BA31 | 7.3140.01170 3RT1936-4BA31 | 7.3140.01170 3RT1936-4BA31 | 7.3140.01170 3RT1936-4BA31 | |
| motor cable -W19.1/19.2 | 4x6 AWWG / 4G16 mm ² 600 V - 90°C | 4x6 AWWG / 4G16 mm ² 600 V - 90°C | 4x6 AWWG / 4G16 mm ² 600 V - 90°C | 4x6 AWWG / 4G16 mm ² 600 V - 90°C | |
| connection -W11 Phase rail -W13 Phase rail -W14 Phase rail | 4 AWG / 25 mm ² 600 V - 90°C | 4 AWG / 25 mm ² 600 V - 90°C | 2 AWG / 35 mm ² 600 V - 90°C | 2 AWG / 35 mm ² 600 V - 90°C | |
| supply terminals -X0: U1/V1/W1/GRD | 3x 895314.0 3x 895314.00010 4x 895314.00040 8-1 AWG / 10-50 mm ² Wago fig. 3, Sht. 11 30 mm | 3x 895314.0 3x 895314.00010 4x 895314.00040 8-1 AWG / 10-50 mm ² Wago fig. 3, Sht. 11 30 mm | 3x 895314.0 3x 895314.00010 4x 895314.00040 8-1 AWG / 10-50 mm ² Wago fig. 3, Sht. 11 30 mm | 3x 895314.0 3x 895314.00010 4x 895314.00040 8-1 AWG / 10-50 mm ² Wago fig. 3, Sht. 11 30 mm | |
| supply Handling Stripped length X connection | fig. 2, Sht. 12 | fig. 2, Sht. 12 | fig. 2, Sht. 12 | fig. 2, Sht. 12 | |

| | | | | | |
|---------------------------------|----------|------------|------------|--------------------------------|--|
| electrical component parts list | | 460V EB+FB | | performance-related components | |
| KAESER KOMPRESSOREN | | Date | 14.12.2020 | Date | |
| c | Drawn | M.Zeesh | | Released | |
| b | Released | M.Zeesh | | Name | |
| a | C Change | | | Date | |

| model | performance-related components | | | | | page 17 28 Sht |
|--|--|--|--|--|--|---|
| | 75 hp EB+ FB-C (55 kW) | 75 hp FB-S (55 kW) | 100 hp EB (75 kW) | 100 hp FB-C (75 kW) | 100 hp FB-S (75 kW) | |
| machine power supply | 460 V ±10 %, 60 Hz | 460 V ±10 %, 60 Hz | 460 V ±10 %, 60 Hz | 460 V ±10 %, 60 Hz | 460 V ±10 %, 60 Hz | = + UXB-STC-U3020.06 |
| overload relay -B21 Siemens | 7.8741.00100 3RB3036-1WB0 20-80 A / S2 setting: 47,9 A NEC 430.32(C) incremental setting: 53,7 A | 7.8741.00100 3RB3036-1WB0 20-80 A / S2 setting: 47,9 A NEC 430.32(C) incremental setting: 53,7 A | 7.8741.00140 3RB3046-1XB0 32-115 A / S3 setting: 64,1 A NEC 430.32(C) incremental setting: 71,8 A | 7.8741.00140 3RB3046-1XB0 32-115 A / S3 setting: 64,1 A NEC 430.32(C) incremental setting: 71,8 A | 7.8741.00140 3RB3046-1XB0 32-115 A / S3 setting: 65,8 A NEC 430.32(C) incremental setting: 73,7 A | |
| overload relay soundproofing casing -B24 Siemens | 7.8741.00020 3RB3016-1NB0 0,32-1,25 A / S00 setting: 0,57 A NEC 430.32(C) incremental setting: 0,64 A | 7.8741.00020 3RB3016-1NB0 0,32-1,25 A / S00 setting: 0,57 A NEC 430.32(C) incremental setting: 0,64 A | 7.8741.00020 3RB3016-1NB0 0,32-1,25 A / S00 setting: 0,57 A NEC 430.32(C) incremental setting: 0,64 A | 7.8741.00020 3RB3016-1NB0 0,32-1,25 A / S00 setting: 0,57 A NEC 430.32(C) incremental setting: 0,64 A | 7.8741.00020 3RB3016-1NB0 0,32-1,25 A / S00 setting: 0,57 A NEC 430.32(C) incremental setting: 0,64 A | electrical component parts list 460V EB+FB performance-related components |
| Blower motor -M1 Siemens | 894717.1 460V-D/60 Hz | 894717.1 460V-D/60 Hz | 894719.1 460V-D/60 Hz | 894719.1 460V-D/60 Hz | 894719.12010 460V-D/60 Hz | |
| vent motor soundproofing casing -M4 Sodeca/ebm | 895040.00040 HC-31-2T / H-I-E 460 V-Y/60 Hz 210W 0,62 A | 895426.0 W4D420 (ebm) 460 V-Y/60 Hz 265W 0,62 A | 895040.00040 HC-31-2T / H-I-E 460 V-Y/60 Hz 210W 0,62 A | 895040.00040 HC-31-2T / H-I-E 460 V-Y/60 Hz 210W 0,62 A | 895426.0 W4D420 (ebm) 460 V-Y/60 Hz 265W 0,62 A | |
| contactor -Q1 / -Q2 | 7.8740.00410 3RT2036-1AK60 | 7.8740.00410 3RT2036-1AK60 | 7.8740.00440 3RT2045-1AK60 | 7.8740.00450 3RT2046-1AK60 | 7.8740.00450 3RT2046-1AK60 | KAESER KOMPRESSOREN |
| auxiliary switch | 7.8740.05030 3RH2911-1HA20 | 7.8740.05030 3RH2911-1HA20 | 7.8740.05030 3RH2911-1HA20 | 7.8740.05030 3RH2911-1HA20 | 7.8740.05030 3RH2911-1HA20 | |
| auxiliary switch | --- | --- | --- | --- | --- | |
| interference suppressor | 7.8740.05150 3RT2936-1CC00 | 7.8740.05150 3RT2936-1CC00 | 7.8740.05170 3RT2946-1CC00 | 7.8740.05170 3RT2946-1CC00 | 7.8740.05170 3RT2946-1CC00 | |
| terminal | 7.3140.05070 3RV2935-5E | 7.3140.05070 3RV2935-5E | --- | --- | --- | |
| Phase rail | 7.3140.05270 3RA2933-3FA00 | 7.3140.05270 3RA2933-3FA00 | --- | --- | --- | |
| contactor -Q3 | 7.8740.00400 3RT2035-1AK60 | 7.8740.00400 3RT2035-1AK60 | 7.8740.00420 3RT2037-1AK60 | 7.8740.00440 3RT2045-1AK60 | 7.8740.00440 3RT2045-1AK60 | |
| auxiliary switch | --- | --- | --- | --- | --- | |
| auxiliary switch | --- | --- | --- | --- | --- | |
| interference suppressor | 7.8740.05150 3RT2936-1CC00 | 7.8740.05150 3RT2936-1CC00 | 7.8740.05150 3RT2936-1CC00 | 7.8740.05170 3RT2946-1CC00 | 7.8740.05170 3RT2946-1CC00 | |
| wye bridge | 7.3140.01170 3RT1936-4BA31 | 7.3140.01170 3RT1936-4BA31 | 7.3140.01170 3RT1936-4BA31 | 7.3140.00940 3RT1946-4BA31 | 7.3140.00940 3RT1946-4BA31 | |
| motor cable -W19.1/19.2 | 4x4 AWG / 4G25 mm ² 600 V - 90°C | 4x4 AWG / 4G25 mm ² 600 V - 90°C | 4x2 AWG / 4G35 mm ² 600 V - 90°C | 4x2 AWG / 4G35 mm ² 600 V - 90°C | 4x2 AWG / 4G35 mm ² 600 V - 90°C | |
| connection -W11 -W13 -W14 | 1 AWG / 50 mm ² Phase rail Phase rail 600 V - 90°C | 1 AWG / 50 mm ² Phase rail Phase rail 600 V - 90°C | 2 AWG / 35 mm ² 2 AWG / 35 mm ² 8 AWG / 10 mm ² 600 V - 90°C | 2 AWG / 35 mm ² 2 AWG / 35 mm ² 8 AWG / 10 mm ² 600 V - 90°C | 2 AWG / 35 mm ² 2 AWG / 35 mm ² 8 AWG / 10 mm ² 600 V - 90°C | |
| supply terminals -X0: U1/V1/W1/PE Handling Stripped length X | 3x 894385.0 3x 894385.00010 4x 894385.00040 Wago 4-4/0 AWG / 25-95 mm ² fig. 3, Sht. 11 36 mm | 3x 894385.0 3x 894385.00010 4x 894385.00040 Wago 4-4/0 AWG / 25-95 mm ² fig. 3, Sht. 11 36 mm | 6x 894385.0 3x 894385.00030 3x 894385.00040 Wago 4-4/0 AWG / 25-95 mm ² fig. 3, Sht. 11 36 mm | 6x 894385.0 3x 894385.00030 3x 894385.00040 Wago 4-4/0 AWG / 25-95 mm ² fig. 3, Sht. 11 36 mm | 6x 894385.0 3x 894385.00030 3x 894385.00040 Wago 4-4/0 AWG / 25-95 mm ² fig. 3, Sht. 11 36 mm | |
| PE-rail -X0:PE Torque Stripped length X | --- | --- | 832489.00010 15Nm 25 mm+ Conductor crimp pins | 832489.00010 15Nm 25 mm+ Conductor crimp pins | 832489.00010 15Nm 25 mm+ Conductor crimp pins | |
| supply -connection | fig. 2, Sht. 12 | fig. 2, Sht. 12 | fig. 3, Sht. 13 | fig. 3, Sht. 13 | fig. 3, Sht. 13 | |
| c | b | a | c | c | c | Date 14.12.2020 |
| | | | | | | M.Zeesh |
| | | | | | | M.Zeesh |
| | | | | | | Released |
| | | | | | | Name |
| | | | | | | Date |
| | | | | | | C Change |

| model | performance-related components | | | | | 18 page 28 Sht |
|---|--|--|--|--|--|-------------------------|
| | 125 hp FB-C (90 kW) | 125 hp FB-S (90 kW) | 150 hp FB-C (110 kW) | 150 hp FB-S (110 kW) | 175 hp FB (132 kW) | |
| machine power supply | 460 V ±10 %, 60 Hz | 460 V ±10 %, 60 Hz | 460 V ±10 %, 60 Hz | 460 V ±10 %, 60 Hz | 460 V ±10 %, 60 Hz | = + UXB-STC-U3020.06 |
| overload relay -B21 Siemens | 7.6873.00240 3RB2056-1FW2 50-200 A / S6 setting: 78,5 A NEC 430.32(C) incremental setting: 87,9 A | 7.6873.00240 3RB2056-1FW2 50-200 A / S6 setting: 77,9 A NEC 430.32(C) incremental setting: 87,3 A | 7.6873.00240 3RB2056-1FW2 50-200 A / S6 setting: 98,2 A NEC 430.32(C) incremental setting: 109,9 A | 7.6873.00240 3RB2056-1FW2 50-200 A / S6 setting: 92,4 A NEC 430.32(C) incremental setting: 103,5 A | 7.6873.00240 3RB2056-1FW2 50-200 A / S6 setting: 114,3 A NEC 430.32(C) incremental setting: 128 A | |
| overload relay soundproofing casing -B24 Siemens | 7.8741.00020 3RB3016-1NB0 0,32-1,25 A / S00 setting: 0,57 A NEC 430.32(C) incremental setting: 0,64 A | 7.8741.00020 3RB3016-1NB0 0,32-1,25 A / S00 setting: 0,57 A NEC 430.32(C) incremental setting: 0,64 A | 7.8741.00020 3RB3016-1NB0 0,32-1,25 A / S00 setting: 0,57 A NEC 430.32(C) incremental setting: 0,64 A | 7.8741.00020 3RB3016-1NB0 0,32-1,25 A / S00 setting: 0,57 A NEC 430.32(C) incremental setting: 0,64 A | 7.8741.00020 3RB3016-1NB0 0,32-1,25 A / S00 setting: 0,57 A NEC 430.32(C) incremental setting: 0,64 A | |
| Blower motor -M1 Siemens | 894723.1 460V-D/60 Hz | 894722.12010 460V-D/60 Hz | 895025.1 460V-D/60 Hz | 894724.1 460V-D/60 Hz | 894726.1 460V-D/60 Hz | |
| vent motor soundproofing casing -M4 Sodeca/ebm | 895040.00040 HC-31-2T / H-I-E 460 V-Y/60 Hz 210W 0,62 A | 895426.0 W4D420 (ebm) 460 V-Y/60 Hz 265W 0,62 A | 895040.00040 HC-31-2T / H-I-E 460 V-Y/60 Hz 210W 0,62 A | 895426.0 W4D420 (ebm) 460 V-Y/60 Hz 265W 0,62 A | 895040.00040 HC-31-2T / H-I-E 460 V-Y/60 Hz 210W 0,62 A | |
| contactor -Q1 / -Q2 | 7.3140.02140 3RT1054-1AF36 | 7.3140.02140 3RT1054-1AF36 | 7.3140.02140 3RT1054-1AF36 | 7.3140.02140 3RT1054-1AF36 | 7.3140.02160 3RT1056-6AF36 | |
| auxiliary switch | 7.3140.01690 3RH1921-1CA10 | 7.3140.01690 3RH1921-1CA10 | 7.3140.01690 3RH1921-1CA10 | 7.3140.01690 3RH1921-1CA10 | 7.3140.01690 3RH1921-1CA10 | |
| auxiliary switch | 7.3140.02030 3RH1921-1CA01 | 7.3140.02030 3RH1921-1CA01 | 7.3140.02030 3RH1921-1CA01 | 7.3140.02030 3RH1921-1CA01 | 7.3140.02030 3RH1921-1CA01 | |
| interference suppressor | 7.3140.02020 3RT1956-1CC00 | 7.3140.02020 3RT1956-1CC00 | 7.3140.02020 3RT1956-1CC00 | 7.3140.02020 3RT1956-1CC00 | 7.3140.02020 3RT1956-1CC00 | |
| terminal | --- | --- | --- | --- | --- | |
| Phase rail | --- | --- | --- | --- | --- | |
| contactor -Q3 | 7.8740.00440 3RT2045-1AK60 | 7.8740.00440 3RT2045-1AK60 | 7.8740.00450 3RT2046-1AK60 | 7.8740.00450 3RT2046-1AK60 | 7.8740.00440 3RT2045-1AK60 | |
| auxiliary switch | --- | --- | --- | --- | --- | |
| auxiliary switch | --- | --- | --- | --- | --- | |
| interference suppressor | 7.8740.05170 3RT2946-1CC00 | 7.8740.05170 3RT2946-1CC00 | 7.8740.05170 3RT2946-1CC00 | 7.8740.05170 3RT2946-1CC00 | 7.8740.05170 3RT2946-1CC00 | |
| wye bridge | 7.3140.00940 3RT1946-4BA31 | 7.3140.00940 3RT1946-4BA31 | 7.3140.00940 3RT1946-4BA31 | 7.3140.00940 3RT1946-4BA31 | 7.3140.00940 3RT1946-4BA31 | |
| motor cable -W19.1/19.2 | 4x1 AWG / 4G50 mm ² 600 V - 90°C | 4x1 AWG / 4G50 mm ² 600 V - 90°C | 4x2/0 AWG / 4G70 mm ² 600 V - 90°C | 4x2/0 AWG / 4G70 mm ² 600 V - 90°C | 4x3/0 AWG / 4G95 mm ² 600 V - 90°C | |
| connection -W11 -W13 -W14 | 1 AWG / 50 mm ² 1 AWG / 50 mm ² 4 AWG / 25 mm ² 600 V - 90°C | 1 AWG / 50 mm ² 1 AWG / 50 mm ² 4 AWG / 25 mm ² 600 V - 90°C | 2/0 AWG / 70 mm ² 2/0 AWG / 70 mm ² 2 AWG / 35 mm ² 600 V - 90°C | 2/0 AWG / 70 mm ² 2/0 AWG / 70 mm ² 2 AWG / 35 mm ² 600 V - 90°C | 3/0 AWG / 95 mm ² 3/0 AWG / 95 mm ² 2 AWG / 35 mm ² 600 V - 90°C | |
| supply terminals -X0: U1/V1/W1 Handling Stripped length X | 6x 894385.0 3x 894385.00030 3x 894385.00040 Wago 4-4/0 AWG / 25-95 mm ² fig. 3, Sht. 11 36 mm | 6x 894385.0 3x 894385.00030 3x 894385.00040 Wago 4-4/0 AWG / 25-95 mm ² fig. 3, Sht. 11 36 mm | 6x 894385.0 3x 894385.00030 3x 894385.00040 Wago 4-4/0 AWG / 25-95 mm ² fig. 3, Sht. 11 36 mm | 6x 894385.0 3x 894385.00030 3x 894385.00040 Wago 4-4/0 AWG / 25-95 mm ² fig. 3, Sht. 11 36 mm | 6x 895545.0 3x 895545.00030 3x 895545.00040 Wago (50-185 mm ²) 1 AWG - 350 MCM fig. 3, Sht. 11 45 mm | |
| PE-rail -X0:PE Torque Stripped length X | 832489.00010 15Nm 25 mm+ Conductor crimp pins | 832489.00010 15Nm 25 mm+ Conductor crimp pins | 832489.00010 15Nm 25 mm+ Conductor crimp pins | 832489.00010 15Nm 25 mm+ Conductor crimp pins | 832489.00010 15Nm 25 mm+ Conductor crimp pins | |
| supply -connection | fig. 3, Sht. 13 | fig. 3, Sht. 13 | fig. 3, Sht. 13 | fig. 3, Sht. 13 | fig. 3, Sht. 13 | |

electrical component parts list

460V FB

KAESER
KOMPRESSOREN

performance-related components

Date 14.12.2020

Drawn M.Zeesh

Released M.Zeesh

Name

Date

C Change

| model | performance-related components | | | | | page 19 28 Sht |
|---|--|--|--|--|--|----------------------|
| | 5 hp BB (4 kW) | 7,5 hp BB+ CB+DB (5,5 kW) | 10 hp BB+ CB+DB (7,5 kW) | 15 hp BB+ CB+DB (11 kW) | 20 hp BB+ CB+DB (15 kW) | |
| machine power supply | 575 V ±10 %, 60 Hz | 575 V ±10 %, 60 Hz | 575 V ±10 %, 60 Hz | 575 V ±10 %, 60 Hz | 575 V ±10 %, 60 Hz | UXB-STC-U3020.06 |
| overload relay -B21 Siemens | 7.8741.00120 3RB3026-1PB0 1-4 A / S0 setting: 2,6 A NEC 430.32(C) incremental setting: 2,9 A | 7.8741.00060 3RB3026-1SB0 3-12 A / S0 setting: 3,7 A NEC 430.32(C) incremental setting: 4,2 A | 7.8741.00060 3RB3026-1SB0 3-12 A / S0 setting: 4,9 A NEC 430.32(C) incremental setting: 5,5 A | 7.8741.00070 3RB3026-1QB0 6-25 A / S0 setting: 7,5 A NEC 430.32(C) incremental setting: 8,5 A | 7.8741.00070 3RB3026-1QB0 6-25 A / S0 setting: 10,2 A NEC 430.32(C) incremental setting: 11,5 A | |
| overload relay soundproofing casing -B24 Siemens | 7.8741.00030 3RB3016-1PB0 1,00-4,00 A / S00 setting: 1,43 A NEC 430.32(C) incremental setting: 1,61 A | 7.8741.00030 3RB3016-1PB0 1,00-4,00 A / S00 setting: 1,43 A NEC 430.32(C) incremental setting: 1,61 A | 7.8741.00030 3RB3016-1PB0 1,00-4,00 A / S00 setting: 1,43 A NEC 430.32(C) incremental setting: 1,61 A | 7.8741.00030 3RB3016-1PB0 1,00-4,00 A / S00 setting: 1,43 A NEC 430.32(C) incremental setting: 1,61 A | 7.8741.00030 3RB3016-1PB0 1,00-4,00 A / S00 setting: 1,43 A NEC 430.32(C) incremental setting: 1,61 A | |
| Blower motor -M1 Siemens | 894969.00500 575V-D/60 Hz | 894970.00500 575V-D/60 Hz | 894971.00500 575V-D/60 Hz | 894972.00500 575V-D/60 Hz | 894973.00500 575V-D/60 Hz | |
| vent motor soundproofing casing -M4 ebm | 895260.00010 W2D250 (1PH/N/GRD) 115 V/60 Hz, 175W 1,55 A | 895260.00010 W2D250 (1PH/N/GRD) 115 V/60 Hz, 175W 1,55 A | 895260.00010 W2D250 (1PH/N/GRD) 115 V/60 Hz, 175W 1,55 A | 895260.00010 W2D250 (1PH/N/GRD) 115 V/60 Hz, 175W 1,55 A | 895260.00010 W2D250 (1PH/N/GRD) 115 V/60 Hz, 175W 1,55 A | |
| contactor -Q1 / -Q2 | 7.8740.00340 3RT2023-1AK60 | 7.8740.00340 3RT2023-1AK60 | 7.8740.00350 3RT2024-1AK60 | 7.8740.00360 3RT2025-1AK60 | 7.8740.00380 3RT2027-1AK60 | |
| auxiliary switch | 7.8740.05030 3RH2911-1HA20 | 7.8740.05030 3RH2911-1HA20 | 7.8740.05030 3RH2911-1HA20 | 7.8740.05030 3RH2911-1HA20 | 7.8740.05030 3RH2911-1HA20 | |
| auxiliary switch | . | . | . | . | . | |
| interference suppressor | 7.8740.05140 3RT2926-1CC00 | 7.8740.05140 3RT2926-1CC00 | 7.8740.05140 3RT2926-1CC00 | 7.8740.05140 3RT2926-1CC00 | 7.8740.05140 3RT2926-1CC00 | |
| terminal | 7.3140.05080 3RV2925-5EB | 7.3140.05080 3RV2925-5EB | 7.3140.05080 3RV2925-5EB | 7.3140.05080 3RV2925-5EB | 7.3140.05080 3RV2925-5EB | |
| Phase rail | 7.6861.0 3RV1915-1AB | 7.6861.0 3RV1915-1AB | 7.6861.0 3RV1915-1AB | 7.6861.0 3RV1915-1AB | 7.6861.0 3RV1915-1AB | |
| contactor -Q3 | 7.8740.00310 3RT2016-1AK61 | 7.8740.00310 3RT2016-1AK61 | 7.8740.00310 3RT2016-1AK61 | 7.8740.00310 3RT2016-1AK61 | 7.8740.00360 3RT2025-1AK60 | |
| auxiliary switch | 7.8740.05010 3RH2911-1HA11 | 7.8740.05010 3RH2911-1HA11 | 7.8740.05010 3RH2911-1HA11 | 7.8740.05010 3RH2911-1HA11 | . | |
| auxiliary switch | . | . | . | . | . | |
| interference suppressor | 7.8740.05130 3RT2916-1CC00 | 7.8740.05130 3RT2916-1CC00 | 7.8740.05130 3RT2916-1CC00 | 7.8740.05130 3RT2916-1CC00 | 7.8740.05140 3RT2926-1CC00 | |
| wye bridge | 7.3140.05030 3RT1916-4BA31 | 7.3140.05030 3RT1916-4BA31 | 7.3140.05030 3RT1916-4BA31 | 7.3140.05030 3RT1916-4BA31 | 7.3140.02070 3RT1926-4BA31 | |
| motor cable -W19.1/19.2 | 4x14 AWG / 4G2,5 mm ² 600 V - 90°C | 4x14 AWG / 4G2,5 mm ² 600 V - 90°C | 4x14 AWG / 4G2,5 mm ² 600 V - 90°C | 4x14 AWG / 4G2,5 mm ² 600 V - 90°C | 4x12 AWG / 4G4 mm ² 600 V - 90°C | |
| connection -W11 -W13 -W14 | 14 AWG / 2,5 mm ² Phase rail 14 AWG / 2,5 mm ² 600 V - 90°C | 14 AWG / 2,5 mm ² Phase rail 14 AWG / 2,5 mm ² 600 V - 90°C | 14 AWG / 2,5 mm ² Phase rail 14 AWG / 2,5 mm ² 600 V - 90°C | 10 AWG / 6 mm ² Phase rail 14 AWG / 2,5 mm ² 600 V - 90°C | 10 AWG / 6 mm ² Phase rail Phase rail 600 V - 90°C | |
| supply terminals -X0: U1/V1/W1/GRD | 894864.00010 | 894864.00010 | 894864.00010 | 894864.00010 | 894864.00010 | |
| Handling Stripped length X connection | 14-4 AWG / 2,5-16 mm ² Wieland fig. 2, Sht. 11 16 mm fig. 1, Sht. 12 | 14-4 AWG / 2,5-16 mm ² Wieland fig. 2, Sht. 11 16 mm fig. 1, Sht. 12 | 14-4 AWG / 2,5-16 mm ² Wieland fig. 2, Sht. 11 16 mm fig. 1, Sht. 12 | 14-4 AWG / 2,5-16 mm ² Wieland fig. 2, Sht. 11 16 mm fig. 1, Sht. 12 | 14-4 AWG / 2,5-16 mm ² Wieland fig. 2, Sht. 11 16 mm fig. 1, Sht. 12 | |
| supply | | | | | | |

electrical component parts list
575V BB+CB+DB
performance-related components



| | |
|----------|------------|
| Date | 14.12.2020 |
| Drawn | M.Zeich |
| Released | M.Zeich |
| C Change | |
| Name | |
| Date | |

| model | performance-related components | | | | |
|---|--|--|--|---|---|
| | 25 hp CB+ DB (18,5 kW) | 30 hp CB+ DB (22 kW) | 40 hp CB+ DB (30 kW) | 50 hp DB (37 kW) | 60 hp DB (45 kW) |
| machine power supply | 575 V ±10 %, 60 Hz | 575 V ±10 %, 60 Hz | 575 V ±10 %, 60 Hz | 575 V ±10 %, 60 Hz | 575 V ±10 %, 60 Hz |
| overload relay -B21 Siemens | 7.8741.00070 3RB3026-1QB0 6-25 A / S0 setting: 11,9 A NEC 430.32(C) incremental setting: 13,5 A | 7.8741.00090 3RB3036-1UB0 12,5-50 A / S2 setting: 14,2 A NEC 430.32(C) incremental setting: 16,1 A | 7.8741.00090 3RB3036-1UB0 12,5-50 A / S2 setting: 21,8 A NEC 430.32(C) incremental setting: 24,6 A | 7.8741.00090 3RB3036-1UB0 12,5-50 A / S2 setting: 26,6 A NEC 430.32(C) incremental setting: 30 A | 7.8741.00090 3RB3036-1UB0 12,5-50 A / S2 setting: 32,9 A NEC 430.32(C) incremental setting: 37,2 A |
| overload relay soundproofing casing -B24 Siemens | 7.8741.00030 3RB3016-1PB0 1,00-4,00 A / S00 setting: 1,43 A NEC 430.32(C) incremental setting: 1,61 A | 7.8741.00030 3RB3016-1PB0 1,00-4,00 A / S00 setting: 1,43 A NEC 430.32(C) incremental setting: 1,61 A | 7.8741.00030 3RB3016-1PB0 1,00-4,00 A / S00 setting: 1,43 A NEC 430.32(C) incremental setting: 1,61 A | 7.8741.00030 3RB3016-1PB0 1,00-4,00 A / S00 setting: 1,43 A NEC 430.32(C) incremental setting: 1,61 A | 7.8741.00030 3RB3016-1PB0 1,00-4,00 A / S00 setting: 1,43 A NEC 430.32(C) incremental setting: 1,61 A |
| Blower motor -M1 Siemens | 8949743.00500 575 V-D/60 Hz | 894975.00500 575 V-D/60 Hz | 894976.10500 (CB) 894977.10500 (DB) 575 V-D/60 Hz | 894978.10500 575 V-D/60 Hz | 894979.10500 575 V-D/60 Hz |
| vent motor soundproofing casing -M4 ebm | 895260.00010 W2D250 (1PH/N/GRD) 115 V/60 Hz, 175W 1,55 A | 895260.00010 W2D250 (1PH/N/GRD) 115 V/60 Hz, 175W 1,55 A | 895260.00010 W2D250 (1PH/N/GRD) 115 V/60 Hz, 175W 1,55 A | 895260.00010 W2D250 (1PH/N/GRD) 115 V/60 Hz, 175W 1,55 A | 895260.00010 W2D250 (1PH/N/GRD) 115 V/60 Hz, 175W 1,55 A |
| contactor -Q1 / -Q2 | 7.8740.00380 3RT2027-1AK60 | 7.8740.00400 3RT2035-1AK60 | 7.8740.00400 3RT2035-1AK60 | 7.8740.00400 3RT2035-1AK60 | 7.8740.00410 3RT2036-1AK60 |
| auxiliary switch | 7.8740.05030 3RH2911-1HA20 | 7.8740.05030 3RH2911-1HA20 | 7.8740.05030 3RH2911-1HA20 | 7.8740.05030 3RH2911-1HA20 | 7.8740.05030 3RH2911-1HA20 |
| auxiliary switch | | | | | |
| interference suppressor | 7.8740.05140 3RT2926-1CC00 | 7.8740.05150 3RT2936-1CC00 | 7.8740.05150 3RT2936-1CC00 | 7.8740.05150 3RT2936-1CC00 | 7.8740.05150 3RT2936-1CC00 |
| terminal | 7.3140.05080 3RV2925-5EB | 7.3140.05070 3RV2935-5E | 7.3140.05070 3RV2935-5E | 7.3140.05070 3RV2935-5E | 7.3140.05070 3RV2935-5E |
| Phase rail | 7.6861.0 3RV1915-1AB | 7.3140.02120 3RV1935-1A | 7.3140.05270 3RA2933-3FA00 | 7.3140.05270 3RA2933-3FA00 | 7.3140.05270 3RA2933-3FA00 |
| contactor -Q3 | 7.8740.00360 3RT2025-1AK60 | 7.8740.00370 3RT2026-1AK60 | 7.8740.00380 3RT2027-1AK60 | 7.8740.00390 3RT2028-1AK60 | 7.8740.00400 3RT2035-1AK60 |
| auxiliary switch | | | | | |
| auxiliary switch | | | | | |
| interference suppressor | 7.8740.05140 3RT2926-1CC00 | 7.8740.05140 3RT2926-1CC00 | 7.8740.05140 3RT2926-1CC00 | 7.8740.05140 3RT2926-1CC00 | 7.8740.05150 3RT2936-1CC00 |
| wye bridge | 7.3140.02070 3RT1926-4BA31 | 7.3140.02070 3RT1926-4BA31 | 7.3140.02070 3RT1926-4BA31 | 7.3140.02070 3RT1926-4BA31 | 7.3140.01170 3RT1936-4BA31 |
| motor cable -W19.1/19.2 | 4x12 AWG / 4G4 mm ² 600 V - 90°C | 4x10 AWG / 4G6 mm ² 600 V - 90°C | 4x8 AWG / 4G10 mm ² 600 V - 90°C | 4x8 AWG / 4G10 mm ² 600 V - 90°C | 4x6 AWG / 4G16 mm ² 600 V - 90°C |
| connection -W11 Phase rail -W13 Phase rail -W14 Phase rail | 10 AWG / 6 mm ² 600 V - 90°C | 8 AWG / 10 mm ² Phase rail 10 AWG / 6 mm ² 600 V - 90°C | 8 AWG / 10 mm ² Phase rail 10 AWG / 6 mm ² 600 V - 90°C | 6 AWG / 16 mm ² Phase rail 10 AWG / 6 mm ² 600 V - 90°C | 4 AWG / 25 mm ² Phase rail Phase rail 600 V - 90°C |
| supply terminals U1/V1/W1/GRD -X0: Handling Stripped length X connection | 894864.00010 14-4 AWG / 2,5-16 mm ² Wieland fig. 2, Sht. 11 16 mm fig. 1, Sht. 12 | 894864.00010 14-4 AWG / 2,5-16 mm ² Wieland fig. 2, Sht. 11 16 mm fig. 1, Sht. 12 | 894864.00010 14-4 AWG / 2,5-16 mm ² Wieland fig. 2, Sht. 11 16 mm fig. 1, Sht. 12 | 3x 895314.0 3x 895314.00010 4x 895314.00040 8-1 AWG / 10-50 mm ² Wago fig. 3, Sht. 11 30 mm fig. 2, Sht. 12 | 3x 895314.0 3x 895314.00010 4x 895314.00040 8-1 AWG / 10-50 mm ² Wago fig. 3, Sht. 11 30 mm fig. 2, Sht. 12 |
| supply | | | | | |

page 20
28 Sht

UXB-STC-U3020.06

electrical component parts list
575V CB+DB
performance-related components

KAESER
KOMPRESSOREN

| | | | | |
|----------|------------|--------|--------|------|
| Date | 14.12.2020 | M.Zeeh | M.Zeeh | Name |
| Drawn | | | | |
| Released | | | | |
| C Change | | | | |

| model | performance-related components | | | | page 21 28 Sht |
|---|--|--|--|--|---|
| | 25 hp EB (18,5 kW) | 30 hp EB (22 kW) | 40 hp EB+ FB-C (30 kW) | 40 hp FB-S (30 kW) | |
| machine power supply | 575 V ±10 %, 60 Hz | 575 V ±10 %, 60 Hz | 575 V ±10 %, 60 Hz | 575 V ±10 %, 60 Hz | = + UXB-STC-U3020.06 |
| overload relay -B21 Siemens | 7.8741.00070 3RB3026-1QB0 6-25 A / S0 setting: 11,9 A NEC 430.32(C) incremental setting: 13,5 A | 7.8741.00090 3RB3036-1UB0 12,5-50 A / S2 setting: 14,2 A NEC 430.32(C) incremental setting: 16,1 A | 7.8741.00090 3RB3036-1UB0 12,5-50 A / S2 setting: 22,0 A NEC 430.32(C) incremental setting: 24,9 A | 7.8741.00090 3RB3036-1UB0 12,5-50 A / S2 setting: 22,0 A NEC 430.32(C) incremental setting: 24,9 A | |
| overload relay soundproofing casing -B24 Siemens | 7.8741.00020 3RB3016-1NB0 0,32-1,25 A / S00 setting: 0,36 A NEC 430.32(C) incremental setting: 0,41 A | 7.8741.00020 3RB3016-1NB0 0,32-1,25 A / S00 setting: 0,36 A NEC 430.32(C) incremental setting: 0,41 A | 7.8741.00020 3RB3016-1NB0 0,32-1,25 A / S00 setting: 0,36 A NEC 430.32(C) incremental setting: 0,41 A | 7.8741.00020 3RB3016-1NB0 0,32-1,25 A / S00 setting: 0,57 A NEC 430.32(C) incremental setting: 0,64 A | electrical component parts list 575V EB+FB performance-related components |
| Blower motor -M1 Siemens | 8949743.00500 575V-D/60 Hz | 894975.00500 575V-D/60 Hz | 894977.10500 575V-D/60 Hz | 894977.10500 575V-D/60 Hz | |
| vent motor soundproofing casing -M4 Sodeca/ebm | 895040.00010 HC-31-2T / H-I-E 575 V-Y/60 Hz 180W 0,39 A | 895040.00010 HC-31-2T / H-I-E 575 V-Y/60 Hz 180W 0,39 A | 895040.00010 HC-31-2T / H-I-E 575 V-Y/60 Hz 180W 0,39 A | 895426.0 W4D420 (ebm) 460 V-Y/60 Hz 265W 0,62 A | |
| auto-transformer -T12 Block | --- | --- | --- | 7.5452.00340 AT3/x 558 VA 575 V/460 V | |
| fuse -12FU Gould | --- | --- | --- | (3x) - 7.3161.00390 ATQR 1 A - 600 V - class CC | |
| fuse socket -12FU Wöhner | --- | --- | --- | 3-pole - 7.3320.00060 class CC-Ambus Easy Switch | |
| contactor -Q1 / -Q2 | 7.8740.00380 3RT2027-1AK60 | 7.8740.00400 3RT2035-1AK60 | 7.8740.00400 3RT2035-1AK60 | 7.8740.00400 3RT2035-1AK60 | KAESER KOMPRESSOREN |
| auxiliary switch | 7.8740.05030 3RH2911-1HA20 | 7.8740.05030 3RH2911-1HA20 | 7.8740.05030 3RH2911-1HA20 | 7.8740.05030 3RH2911-1HA20 | |
| auxiliary switch | 7.8740.05140 3RT2926-1CC00 | 7.8740.05150 3RT2936-1CC00 | 7.8740.05150 3RT2936-1CC00 | 7.8740.05150 3RT2936-1CC00 | |
| interference suppressor | 7.3140.05080 3RV2925-5EB | 7.3140.05070 3RV2935-5E | 7.3140.05070 3RV2935-5E | 7.3140.05070 3RV2935-5E | |
| terminal | 7.6861.0 3RV1915-1AB | 7.3140.05270 3RA2933-3FA00 | 7.3140.05270 3RA2933-3FA00 | 7.3140.05270 3RA2933-3FA00 | |
| Phase rail | --- | --- | --- | --- | |
| contactor -Q3 | 7.8740.00360 3RT2025-1AK60 | 7.8740.00370 3RT2026-1AK60 | 7.8740.00380 3RT2027-1AK60 | 7.8740.00380 3RT2027-1AK60 | |
| auxiliary switch | --- | --- | --- | --- | |
| auxiliary switch | --- | --- | --- | --- | |
| interference suppressor | 7.8740.05140 3RT2926-1CC00 | 7.8740.05140 3RT2926-1CC00 | 7.8740.05140 3RT2926-1CC00 | 7.8740.05140 3RT2926-1CC00 | |
| wye bridge | 7.3140.02070 3RT1926-4BA31 | 7.3140.02070 3RT1926-4BA31 | 7.3140.02070 3RT1926-4BA31 | 7.3140.02070 3RT1926-4BA31 | |
| motor cable -W19.1/19.2 | 4x12 AWG / 4G4 mm ² 600 V - 90°C | 4x10 AWG / 4G6 mm ² 600 V - 90°C | 4x8 AWWG / 4G10 mm ² 600 V - 90°C | 4x8 AWWG / 4G10 mm ² 600 V - 90°C | Date 14.12.2020 |
| connection -W11 -W13 -W14 | 10 AWG / 6 mm ² Phase rail Phase rail 600 V - 90°C | 8 AWG / 10 mm ² Phase rail 14 AWG / 2,5 mm ² 600 V - 90°C | 6 AWG / 16 mm ² Phase rail 10 AWG / 6 mm ² 600 V - 90°C | 6 AWG / 16 mm ² Phase rail 10 AWG / 6 mm ² 600 V - 90°C | M.Zeesh M.Zeesh Released Name |
| Fortsetzung: nächstes Blatt | | | | | Date Date C Change |

| model | performance-related components | | | | page 22 28 Sht |
|---|---|---|--|--|---|
| | 25 hp EB (18,5 kW) | 30 hp EB (22 kW) | 40 hp EB+ FB-C (30 kW) | 40 hp FB-S (30 kW) | |
| machine power supply | 575 V ±10 %, 60 Hz | 575 V ±10 %, 60 Hz | 575 V ±10 %, 60 Hz | 575 V ±10 %, 60 Hz | = + UXB-STC-U3020.06 |
| supply terminals -X0: U1/V1/W1/GRD | 894864.00010 | 894864.00010 | 3x 895314.0 3x 895314.00010 4x 895314.00040 | 3x 895314.0 3x 895314.00010 4x 895314.00040 | |
| Handling Stripped length X connection | 14-4 AWG / 2,5-16 mm ² Wieland fig. 2, Sht. 11 16 mm fig. 1, Sht. 12 | 14-4 AWG / 2,5-16 mm ² Wieland fig. 2, Sht. 11 16 mm fig. 1, Sht. 12 | 8-1 AWG / 10-50 mm ² Wago fig. 3, Sht. 11 30 mm fig. 2, Sht. 12 | 8-1 AWG / 10-50 mm ² Wago fig. 3, Sht. 11 30 mm fig. 2, Sht. 12 | |
| | | | | | electrical component parts list 575V EB+FB performance-related components |
| KAESER KOMPRESSOREN | | | | | |
| c | Date | 14.12.2020 | | | |
| b | Drawn | M.Zeesh | | | |
| a | Released | M.Zeesh | | | |
| C Change | Date | | Name | | |

| model | performance-related components | | | | page 23 | 28 Sht |
|---|--|--|--|--|------------|--------|
| | 50 hp EB+ FB-C (37 kW) | 50 hp FB-S (37 kW) | 60 hp EB+ FB-C (45 kW) | 60 hp FB-S (45 kW) | | |
| machine power supply | 575 V ±10 %, 60 Hz | 575 V ±10 %, 60 Hz | 575 V ±10 %, 60 Hz | 575 V ±10 %, 60 Hz | = | + |
| overload relay -B21 Siemens | 7.8741.00090 3RB3036-1UB0 12,5-50 A / S2 setting: 26,6 A NEC 430.32(C) incremental setting: 30 A | 7.8741.00090 3RB3036-1UB0 12,5-50 A / S2 setting: 26,6 A NEC 430.32(C) incremental setting: 30 A | 7.8741.00090 3RB3036-1UB0 12,5-50 A / S2 setting: 32,9 A NEC 430.32(C) incremental setting: 37,2 A | 7.8741.00090 3RB3036-1UB0 12,5-50 A / S2 setting: 32,9 A NEC 430.32(C) incremental setting: 37,2 A | | |
| overload relay soundproofing casing -B24 Siemens | 7.8741.00020 3RB3016-1NB0 0,32-1,25 A / S00 setting: 0,36 A NEC 430.32(C) incremental setting: 0,41 A | 7.8741.00020 3RB3016-1NB0 0,32-1,25 A / S00 setting: 0,57 A NEC 430.32(C) incremental setting: 0,64 A | 7.8741.00020 3RB3016-1NB0 0,32-1,25 A / S00 setting: 0,36 A NEC 430.32(C) incremental setting: 0,41 A | 7.8741.00020 3RB3016-1NB0 0,32-1,25 A / S00 setting: 0,57 A NEC 430.32(C) incremental setting: 0,64 A | | |
| Blower motor -M1 Siemens | 894978.10500 575V-D/60 Hz | 894978.10500 575V-D/60 Hz | 894979.10500 575V-D/60 Hz | 894979.10500 575V-D/60 Hz | | |
| vent motor soundproofing casing -M4 Sodeca/ebm | 895040.00010 HC-31-2T / H-I-E 575 V-Y/60 Hz 180W 0,39 A | 895426.0 W4D420 (ebm) 460 V-Y/60 Hz 265W 0,62 A | 895040.00010 HC-31-2T / H-I-E 575 V-Y/60 Hz 180W 0,39 A | 895426.0 W4D420 (ebm) 460 V-Y/60 Hz 265W 0,62 A | | |
| auto-transformer -T12 Block | --- | 7.5452.00340 AT3/x 558 VA 575 V/460 V | --- | 7.5452.00340 AT3/x 558 VA 575 V/460 V | | |
| fuse -12FU Gould | --- | (3x) - 7.3161.00390 ATQR 1 A - 600 V - class CC | --- | (3x) - 7.3161.00390 ATQR 1 A - 600 V - class CC | | |
| fuse socket -12FU Wöhner | --- | 3-pole - 7.3320.00060 class CC-Ambus Easy Switch | --- | 3-pole - 7.3320.00060 class CC-Ambus Easy Switch | | |
| contactor -Q1 / -Q2 | 7.8740.00400 3RT2035-1AK60 | 7.8740.00400 3RT2035-1AK60 | 7.8740.00410 3RT2036-1AK60 | 7.8740.00410 3RT2036-1AK60 | | |
| auxiliary switch | 7.8740.05030 3RH2911-1HA20 | 7.8740.05030 3RH2911-1HA20 | 7.8740.05030 3RH2911-1HA20 | 7.8740.05030 3RH2911-1HA20 | | |
| auxiliary switch | | | | | | |
| interference suppressor | 7.8740.05150 3RT2936-1CC00 | 7.8740.05150 3RT2936-1CC00 | 7.8740.05150 3RT2936-1CC00 | 7.8740.05150 3RT2936-1CC00 | | |
| terminal | 7.3140.05070 3RV2935-5E | 7.3140.05070 3RV2935-5E | 7.3140.05070 3RV2935-5E | 7.3140.05070 3RV2935-5E | | |
| Phase rail | 7.3140.05270 3RA2933-3FA00 | 7.3140.05270 3RA2933-3FA00 | 7.3140.05270 3RA2933-3FA00 | 7.3140.05270 3RA2933-3FA00 | | |
| contactor -Q3 | 7.8740.00400 3RT2035-1AK60 | 7.8740.00400 3RT2035-1AK60 | 7.8740.00400 3RT2035-1AK60 | 7.8740.00400 3RT2035-1AK60 | | |
| auxiliary switch | | | | | | |
| auxiliary switch | | | | | | |
| interference suppressor | 7.8740.05150 3RT2936-1CC00 | 7.8740.05150 3RT2936-1CC00 | 7.8740.05150 3RT2936-1CC00 | 7.8740.05150 3RT2936-1CC00 | | |
| wye bridge | 7.3140.01170 3RT1936-4BA31 | 7.3140.01170 3RT1936-4BA31 | 7.3140.01170 3RT1936-4BA31 | 7.3140.01170 3RT1936-4BA31 | | |
| motor cable -W19.1/19.2 | 4x8 AWWG / 4G10 mm ² 600 V - 90°C | 4x8 AWWG / 4G10 mm ² 600 V - 90°C | 4x8 AWWG / 4G10 mm ² 600 V - 90°C | 4x8 AWWG / 4G10 mm ² 600 V - 90°C | | |
| connection -W11 -W13 -W14 | 6 AWG / 16 mm ² Phase rail Phase rail 600 V - 90°C | 6 AWG / 16 mm ² Phase rail Phase rail 600 V - 90°C | 4 AWG / 25 mm ² Phase rail Phase rail 600 V - 90°C | 4 AWG / 25 mm ² Phase rail Phase rail 600 V - 90°C | | |
| Fortsetzung: nächstes Blatt | | | | | | |

electrical component parts list
575V EB+FB
performance-related components

KAESER
KOMPRESSOREN

| | | |
|---|----------|------------|
| c | Date | 14.12.2020 |
| b | Drawn | M.Zeesh |
| a | Released | M.Zeesh |
| C | Change | |
| | Name | |
| | Date | |

| model | performance-related components | | | | | page 25 28 Sht | | | | | | | | | | | | | | | |
|---|--|--|--|--|--|--|---|------|------------|---|-------|---------|---|----------|---------|----------|------|--|--|------|--|
| | 75 hp EB+ FB-C (55 kW) | 75 hp FB-S (55 kW) | 100 hp EB-C (75 kW) | 100 hp FB-C (75 kW) | 100 hp FB-S (75 kW) | | | | | | | | | | | | | | | | |
| machine power supply | 575 V ±10 %, 60 Hz | 575 V ±10 %, 60 Hz | 575 V ±10 %, 60 Hz | 575 V ±10 %, 60 Hz | 575 V ±10 %, 60 Hz | = + UXB-STC-U3020.06 | | | | | | | | | | | | | | | |
| overload relay -B21 Siemens | 7.8741.00100 3RB3036-1WB0 20-80 A / S2 setting: 39,1 A NEC 430.32(C) incremental setting: 44,2 A | 7.8741.00100 3RB3036-1WB0 20-80 A / S2 setting: 39,1 A NEC 430.32(C) incremental setting: 44,2 A | 7.8741.00100 3RB3036-1WB0 20-80 A / S2 setting: 53,6 A NEC 430.32(C) incremental setting: 60,6 A | 7.8741.00100 3RB3036-1WB0 20-80 A / S2 setting: 53,6 A NEC 430.32(C) incremental setting: 60,6 A | 7.8741.00100 3RB3036-1WB0 20-80 A / S2 setting: 53,6 A NEC 430.32(C) incremental setting: 60,6 A | | | | | | | | | | | | | | | | |
| overload relay soundproofing casing -B24 Siemens | 7.8741.00020 3RB3016-1NB0 0,32-1,25 A / S00 setting: 0,36 A NEC 430.32(C) incremental setting: 0,41 A | 7.8741.00020 3RB3016-1NB0 0,32-1,25 A / S00 setting: 0,57 A NEC 430.32(C) incremental setting: 0,64 A | 7.8741.00020 3RB3016-1NB0 0,32-1,25 A / S00 setting: 0,36 A NEC 430.32(C) incremental setting: 0,41 A | 7.8741.00020 3RB3016-1NB0 0,32-1,25 A / S00 setting: 0,36 A NEC 430.32(C) incremental setting: 0,41 A | 7.8741.00020 3RB3016-1NB0 0,32-1,25 A / S00 setting: 0,57 A NEC 430.32(C) incremental setting: 0,64 A | electrical component parts list 575V EB+FB performance-related components | | | | | | | | | | | | | | | |
| Blower motor -M1 Siemens | 894717.10500 575V-D/60 Hz | 894717.10500 575V-D/60 Hz | 894719.10500 575V-D/60 Hz | 894719.10500 575V-D/60 Hz | 894719.10500 575V-D/60 Hz | | | | | | | | | | | | | | | | |
| vent motor soundproofing casing -M4 Sodeca/ebm | 895040.00010 HC-31-2T / H-I-E 575 V-Y/60 Hz 180W 0,39 A | 895426.0 W4D420 (ebm) 460 V-Y/60 Hz 265W 0,62 A | 895040.00010 HC-31-2T / H-I-E 575 V-Y/60 Hz 180W 0,39 A | 895040.00010 HC-31-2T / H-I-E 575 V-Y/60 Hz 180W 0,39 A | 895426.0 W4D420 (ebm) 460 V-Y/60 Hz 265W 0,62 A | | | | | | | | | | | | | | | | |
| auto-transformer -T12 Block | --- | 7.5452.00340 AT3/x 558 VA 575 V/460 V | --- | --- | 7.5452.00340 AT3/x 558 VA 575 V/460 V | | | | | | | | | | | | | | | | |
| fuse -12FU Gould | --- | (3x) - 7.3161.00390 ATQR 1 A - 600 V - class CC | --- | --- | (3x) - 7.3161.00390 ATQR 1 A - 600 V - class CC | | | | | | | | | | | | | | | | |
| fuse socket -12FU Wöhner | --- | 3-pole - 7.3320.00060 class CC-Ambus Easy Switch | --- | --- | 3-pole - 7.3320.00060 class CC-Ambus Easy Switch | | | | | | | | | | | | | | | | |
| contactor -Q1 / -Q2 | 7.8740.00400 3RT2035-1AK60 | 7.8740.00400 3RT2035-1AK60 | 7.8740.00430 3RT2038-1AK60 | 7.8740.00430 3RT2038-1AK60 | 7.8740.00430 3RT2038-1AK60 | KAESER KOMPRESSOREN | | | | | | | | | | | | | | | |
| auxiliary switch | 7.8740.05030 3RH2911-1HA20 | 7.8740.05030 3RH2911-1HA20 | 7.8740.05030 3RH2911-1HA20 | 7.8740.05030 3RH2911-1HA20 | 7.8740.05030 3RH2911-1HA20 | | | | | | | | | | | | | | | | |
| auxiliary switch | 7.8740.05150 3RT2936-1CC00 | 7.8740.05150 3RT2936-1CC00 | 7.8740.05150 3RT2936-1CC00 | 7.8740.05150 3RT2936-1CC00 | 7.8740.05150 3RT2936-1CC00 | | | | | | | | | | | | | | | | |
| interference suppressor | 7.3140.05070 3RV2935-5E | 7.3140.05070 3RV2935-5E | 7.3140.05270 3RV2935-5E | 7.3140.05270 3RV2935-5E | 7.3140.05270 3RV2935-5E | | | | | | | | | | | | | | | | |
| terminal | 7.3140.05270 3RA2933-3FA00 | 7.3140.05270 3RA2933-3FA00 | 7.3140.05270 3RA2933-3FA00 | 7.3140.05270 3RA2933-3FA00 | 7.3140.05270 3RA2933-3FA00 | | | | | | | | | | | | | | | | |
| Phase rail | --- | --- | --- | --- | --- | | | | | | | | | | | | | | | | |
| contactor -Q3 | 7.8740.00400 3RT2035-1AK60 | 7.8740.00400 3RT2035-1AK60 | 7.8740.00400 3RT2035-1AK60 | 7.8740.00400 3RT2035-1AK60 | 7.8740.00400 3RT2035-1AK60 | | | | | | | | | | | | | | | | |
| auxiliary switch | 7.8740.05150 3RT2936-1CC00 | 7.8740.05150 3RT2936-1CC00 | 7.8740.05150 3RT2936-1CC00 | 7.8740.05150 3RT2936-1CC00 | 7.8740.05150 3RT2936-1CC00 | | | | | | | | | | | | | | | | |
| auxiliary switch | 7.3140.01170 3RT1936-4BA31 | 7.3140.01170 3RT1936-4BA31 | 7.3140.01170 3RT1936-4BA31 | 7.3140.01170 3RT1936-4BA31 | 7.3140.01170 3RT1936-4BA31 | | | | | | | | | | | | | | | | |
| interference suppressor | --- | --- | --- | --- | --- | | | | | | | | | | | | | | | | |
| wye bridge | --- | --- | --- | --- | --- | | | | | | | | | | | | | | | | |
| motor cable -W19.1/19.2 | 4x6 AWWG / 4G16 mm² 600 V - 90°C | 4x6 AWWG / 4G16 mm² 600 V - 90°C | 4x4 AWG / 4G25 mm² 600 V - 90°C | 4x4 AWG / 4G25 mm² 600 V - 90°C | 4x4 AWG / 4G25 mm² 600 V - 90°C | | | | | | | | | | | | | | | | |
| connection -W11 -W13 -W14 | 2 AWG / 35 mm² Phase rail 600 V - 90°C | 2 AWG / 35 mm² Phase rail 600 V - 90°C | 1 AWG/50 mm² Phase rail 600 V - 90°C | 1 AWG/50 mm² Phase rail 600 V - 90°C | 1 AWG/50 mm² Phase rail 600 V - 90°C | | | | | | | | | | | | | | | | |
| Fortsetzung: nächstes Blatt | | | | | | <table border="1"> <tr> <td>c</td> <td>Date</td> <td>14.12.2020</td> </tr> <tr> <td>b</td> <td>Drawn</td> <td>M.Zeesh</td> </tr> <tr> <td>a</td> <td>Released</td> <td>M.Zeesh</td> </tr> <tr> <td>C Change</td> <td>Name</td> <td></td> </tr> <tr> <td></td> <td>Date</td> <td></td> </tr> </table> | c | Date | 14.12.2020 | b | Drawn | M.Zeesh | a | Released | M.Zeesh | C Change | Name | | | Date | |
| c | Date | 14.12.2020 | | | | | | | | | | | | | | | | | | | |
| b | Drawn | M.Zeesh | | | | | | | | | | | | | | | | | | | |
| a | Released | M.Zeesh | | | | | | | | | | | | | | | | | | | |
| C Change | Name | | | | | | | | | | | | | | | | | | | | |
| | Date | | | | | | | | | | | | | | | | | | | | |

| model | performance-related components | | | | | page 26 28 Sht | | | | | | |
|--|--|--|---|--|--|---|----------|--|------------|----------|--|--|
| | 75 hp EB+ FB-C (55 kW) | 75 hp FB-S (55 kW) | 100 hp EB-C (75 kW) | 100 hp FB-C (75 kW) | 100 hp FB-S (75 kW) | | | | | | | |
| machine power supply | 575 V ±10 %, 60 Hz | 575 V ±10 %, 60 Hz | 575 V ±10 %, 60 Hz | 575 V ±10 %, 60 Hz | 575 V ±10 %, 60 Hz | = + UXB-STC-U3020.06 | | | | | | |
| supply terminals -X0: U1/V1/W1/PE | 3x 895314.0 3x 895314.00010 4x 895314.00040 8-1 AWG / 10-50 mm ² Wago | 3x 895314.0 3x 895314.00010 4x 895314.00040 8-1 AWG / 10-50 mm ² Wago | 6x 894385.0 (Wago) 3x 894385.00030 3x 894385.00040 4-4/0 AWG / 25-95 mm ² Wago | 3x 894385.0 3x 894385.00010 4x 894385.00040 4-4/0 AWG / 25-95 mm ² Wago | 3x 894385.0 3x 894385.00010 4x 894385.00040 4-4/0 AWG / 25-95 mm ² Wago | | | | | | | |
| Handling | fig. 3, Sht. 11 | fig. 3, Sht. 11 | fig. 3, Sht. 11 | fig. 3, Sht. 11 | fig. 3, Sht. 11 | | | | | | | |
| Torque | --- | --- | --- | --- | --- | | | | | | | |
| Stripped length X | 30 mm | 30 mm | 36 mm | 36 mm | 36 mm | | | | | | | |
| PE-rail | --- | --- | 832489.00010 (PE) | --- | --- | | | | | | | |
| Torque | --- | --- | 133lb-in | --- | --- | | | | | | | |
| Stripped length X | --- | --- | 25 mm | --- | --- | | | | | | | |
| supply connection | fig. 2, Sht. 12 | fig. 2, Sht. 12 | + Conductor crimp pins fig. 3, Sht. 13 | fig. 2, Sht. 12 | fig. 2, Sht. 12 | | | | | | | |
| <div style="text-align: center;">  </div> | | | | | | electrical component parts list 575V EB+FB performance-related components | | | | | | |
| | | | | | | | Date | | 14.12.2020 | Date | | |
| | | | | | | | Drawn | | M.Zeeh | Released | | |
| | | | | | | | Released | | M.Zeeh | Name | | |
| | | | | | | | C Change | | | Date | | |

| model | performance-related components | | | | | page 27 28 Sht |
|---|--|--|--|--|--|-------------------------|
| | 125 hp FB-C (90 kW) | 125 hp FB-S (90 kW) | 150 hp FB-C (110 kW) | 150 hp FB-S (110 kW) | 175 hp FB (132 kW) | |
| machine power supply | 575 V ±10 %, 60 Hz | 575 V ±10 %, 60 Hz | 575 V ±10 %, 60 Hz | 575 V ±10 %, 60 Hz | 575 V ±10 %, 60 Hz | = + UXB-STC-U3020.06 |
| overload relay -B21 Siemens | 7.6873.00240 3RB2056-1FW2 50-200 A / S6 setting: 67,1 A NEC 430.32(C) incremental setting: 75,9 A | 7.6873.00240 3RB2056-1FW2 50-200 A / S6 setting: 63,3 A NEC 430.32(C) incremental setting: 71,6 A | 7.6873.00240 3RB2056-1FW2 50-200 A / S6 setting: 79,7 A NEC 430.32(C) incremental setting: 90,1 A | 7.6873.00240 3RB2056-1FW2 50-200 A / S6 setting: 78,6 A NEC 430.32(C) incremental setting: 88,9 A | 7.6873.00240 3RB2056-1FW2 50-200 A / S6 setting: 95,6 A NEC 430.32(C) incremental setting: 108,1 A | |
| overload relay soundproofing casing -B24 Siemens | 7.8741.00020 3RB3016-1NB0 0,32-1,25 A / S00 setting: 0,36 A NEC 430.32(C) incremental setting: 0,41 A | 7.8741.00020 3RB3016-1NB0 0,32-1,25 A / S00 setting: 0,57 A NEC 430.32(C) incremental setting: 0,64 A | 7.8741.00020 3RB3016-1NB0 0,32-1,25 A / S00 setting: 0,36 A NEC 430.32(C) incremental setting: 0,41 A | 7.8741.00020 3RB3016-1NB0 0,32-1,25 A / S00 setting: 0,57 A NEC 430.32(C) incremental setting: 0,64 A | 7.8741.00020 3RB3016-1NB0 0,32-1,25 A / S00 setting: 0,36 A NEC 430.32(C) incremental setting: 0,41 A | |
| Blower motor -M1 Siemens | 894723.10500 575V-D/60 Hz | 894722.10500 575V-D/60 Hz | 895025.10500 575V-D/60 Hz | 894724.10500 575V-D/60 Hz | 894726.10500 575V-D/60 Hz | |
| vent motor soundproofing casing -M4 Sodeca/ebm | 895040.00010 HC-31-2T / H-I-E 575 V-Y/60 Hz 180W 0,39 A | 895426.0 W4D420 (ebm) 460 V-Y/60 Hz 265W 0,62 A | 895040.00010 HC-31-2T / H-I-E 575 V-Y/60 Hz 180W 0,39 A | 895426.0 W4D420 (ebm) 460 V-Y/60 Hz 265W 0,62 A | 895040.00010 HC-31-2T / H-I-E 575 V-Y/60 Hz 180W 0,39 A | |
| auto-transformer -T12 Block | --- | 7.5452.00340 AT3/x 558 VA 575 V/460 V | --- | 7.5452.00340 AT3/x 558 VA 575 V/460 V | --- | |
| fuse -12FU Gould | --- | (3x) - 7.3161.00390 ATQR 1 A - 600 V - class CC | --- | (3x) - 7.3161.00390 ATQR 1 A - 600 V - class CC | --- | |
| fuse socket -12FU Wöhner | --- | 3-pole (2x) - 7.3320.00060 class CC-Ambus Easy Switch | --- | 3-pole (2x) - 7.3320.00060 class CC-Ambus Easy Switch | --- | |
| contactor -Q1 / -Q2 Siemens | 7.3140.02140 3RT1054-1AF36 | 7.3140.02140 3RT1054-1AF36 | 7.3140.02140 3RT1054-1AF36 | 7.3140.02140 3RT1054-1AF36 | 7.3140.02140 3RT1054-1AF36 | |
| auxiliary switch | 7.3140.01690 3RH1921-1CA10 | 7.3140.01690 3RH1921-1CA10 | 7.3140.01690 3RH1921-1CA10 | 7.3140.01690 3RH1921-1CA10 | 7.3140.01690 3RH1921-1CA10 | |
| auxiliary switch | 7.3140.02030 3RH1921-1CA01 | 7.3140.02030 3RH1921-1CA01 | 7.3140.02030 3RH1921-1CA01 | 7.3140.02030 3RH1921-1CA01 | 7.3140.02030 3RH1921-1CA01 | |
| interference suppressor | 7.3140.02020 3RT1956-1CC00 | 7.3140.02020 3RT1956-1CC00 | 7.3140.02020 3RT1956-1CC00 | 7.3140.02020 3RT1956-1CC00 | 7.3140.02020 3RT1956-1CC00 | |
| terminal | --- | --- | --- | --- | --- | |
| Phase rail | --- | --- | --- | --- | --- | |
| contactor -Q3 Siemens | 7.8740.00410 3RT2036-1AK60 | 7.8740.00410 3RT2036-1AK60 | 7.8740.00440 3RT2045-1AK60 | 7.8740.00440 3RT2045-1AK60 | 7.8740.00440 3RT2045-1AK60 | |
| auxiliary switch | --- | --- | --- | --- | --- | |
| auxiliary switch | --- | --- | --- | --- | --- | |
| interference suppressor | 7.8740.05150 3RT2936-1CC00 | 7.8740.05150 3RT2936-1CC00 | 7.8740.05170 3RT2946-1CC00 | 7.8740.05170 3RT2946-1CC00 | 7.8740.05170 3RT2946-1CC00 | |
| wye bridge | 7.3140.01170 3RT1936-4BA31 | 7.3140.01170 3RT1936-4BA31 | 7.3140.00940 3RT1946-4BA31 | 7.3140.00940 3RT1946-4BA31 | 7.3140.00940 3RT1946-4BA31 | |
| motor cable -W19.1/19.2 | 4x2 AWG / 4G35 mm ² 600 V - 90°C | 4x2 AWG / 4G35 mm ² 600 V - 90°C | 4x1 AWG / 4G50 mm ² 600 V - 90°C | 4x1 AWG / 4G50 mm ² 600 V - 90°C | 4x2/0 AWG / 4G70 mm ² 600 V - 90°C | |
| connection -W11 -W13 -W14 | 2 AWG / 35 mm ² 2 AWG / 35 mm ² 8 AWG / 10 mm ² 600 V - 90°C | 2 AWG / 35 mm ² 2 AWG / 35 mm ² 8 AWG / 10 mm ² 600 V - 90°C | 1 AWG / 50 mm ² 1 AWG / 50 mm ² 6 AWG / 16 mm ² 600 V - 90°C | 1 AWG / 50 mm ² 1 AWG / 50 mm ² 6 AWG / 16 mm ² 600 V - 90°C | 1 AWG / 50 mm ² 1 AWG / 50 mm ² 4 AWG / 25 mm ² 600 V - 90°C | |
| Fortsetzung: nächstes Blatt | | | | | | |

electrical component parts list
575V FB
performance-related components

KAESER
KOMPRESSOREN

| | | |
|---|----------|------------|
| c | Date | 14.12.2020 |
| b | Drawn | M.Zeesh |
| a | Released | M.Zeesh |
| C | Change | |
| | Name | |
| | Date | |

| model | performance-related components | | | | | page 28 28 Sht | | | | | | | | | | | | |
|---|--|--|--|--|--|-------------------------|--|---|--|--|--|--|--|--|--|--|--|--|
| | 125 hp FB-C (90 kW) | 125 hp FB-S (90 kW) | 150 hp FB-C (110 kW) | 150 hp FB-S (110 kW) | 175 hp FB (132 kW) | | | | | | | | | | | | | |
| machine power supply | 575 V ±10 %, 60 Hz | 575 V ±10 %, 60 Hz | 575 V ±10 %, 60 Hz | 575 V ±10 %, 60 Hz | 575 V ±10 %, 60 Hz | = + UXB-STC-U3020.06 | | | | | | | | | | | | |
| supply terminals -X0: U1/V1/W1 Handling Stripped length X | 6x 894385.0 3x 894385.00030 3x 894385.00040 Wago 4-4/0 AWG / 25-95 mm² fig. 3, Sht. 11 36 mm | 6x 894385.0 3x 894385.00030 3x 894385.00040 Wago 4-4/0 AWG / 25-95 mm² fig. 3, Sht. 11 36 mm | 6x 894385.0 3x 894385.00030 3x 894385.00040 Wago 4-4/0 AWG / 25-95 mm² fig. 3, Sht. 11 36 mm | 6x 894385.0 3x 894385.00030 3x 894385.00040 Wago 4-4/0 AWG / 25-95 mm² fig. 3, Sht. 11 36 mm | 6x 894385.0 3x 894385.00030 3x 894385.00040 Wago 4-4/0 AWG / 25-95 mm² fig. 3, Sht. 11 36 mm | | | | | | | | | | | | | |
| PE-rail -X0:PE Torque Stripped length X | 832489.00010 15Nm 25 mm+ Conductor crimp pins | 832489.00010 15Nm 25 mm+ Conductor crimp pins | 832489.00010 15Nm 25 mm+ Conductor crimp pins | 832489.00010 15Nm 25 mm+ Conductor crimp pins | 832489.00010 15Nm 25 mm+ Conductor crimp pins | | | | | | | | | | | | | |
| supply -connection | fig. 3, Sht. 13 | fig. 3, Sht. 13 | fig. 3, Sht. 13 | fig. 3, Sht. 13 | fig. 3, Sht. 13 | | | | | | | | | | | | | |
| | | | | | | | electrical component parts list 575V FB performance-related components | | | | | | | | | | | |
| | | | | | | | |  | | | | | | | | | | |
| | | | | | | | | | | | | | | | | | | |
| | | | | | | | | | | | | | | | | | | |
| Date | 14.12.2020 | Drawn | M.Zeeh | Released | M.Zeeh | | | | | | | | | | | | | |
| C Change | | | | | | | | | | | | | | | | | | |

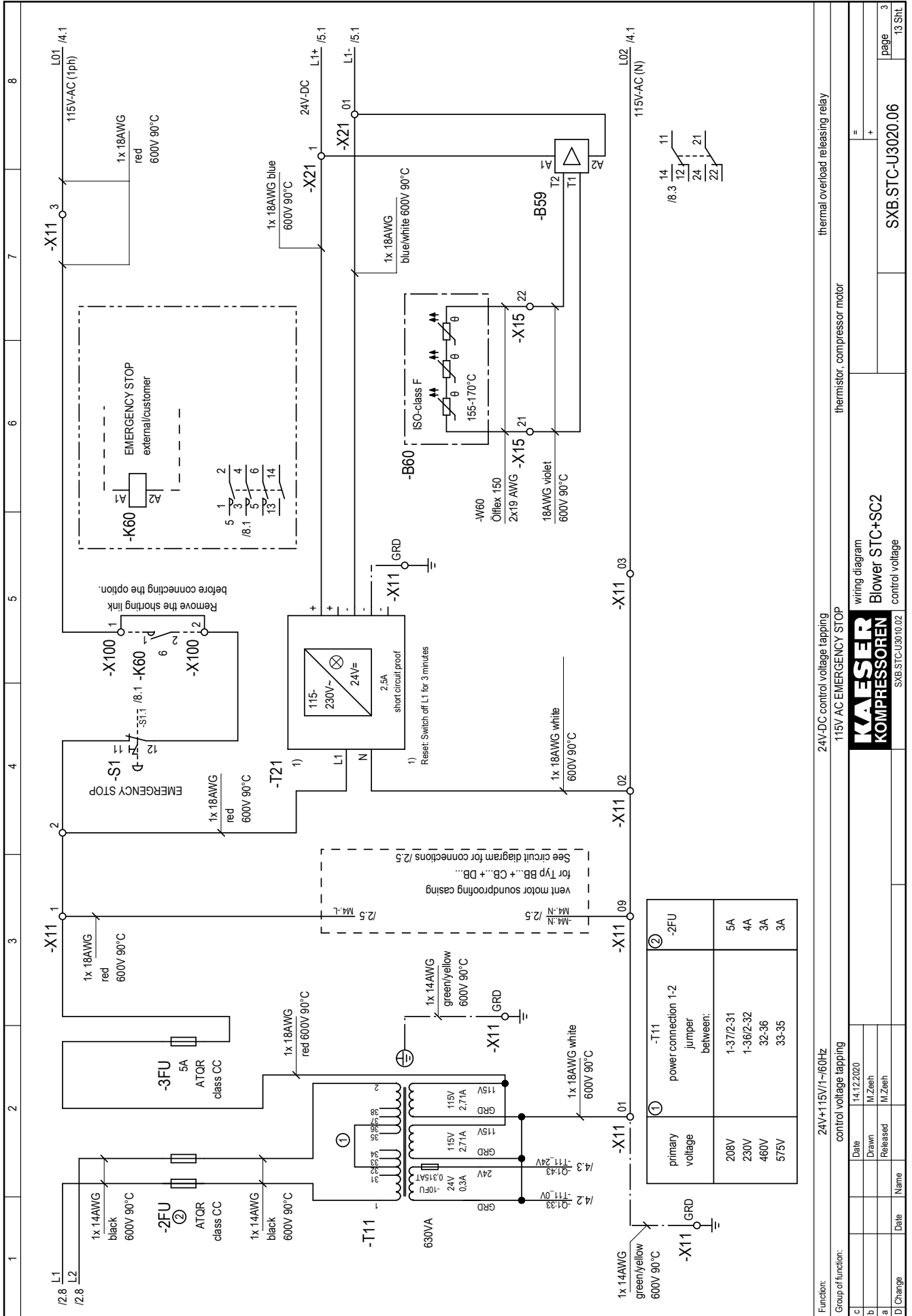

| | | | | | |
|---------------------|----------|--------------------------------|--|----------------------------------|--|
| Function: | | 24V-DC control voltage tapping | | thermal overload releasing relay | |
| Group of function: | | 115V AC EMERGENCY STOP | | thermistor, compressor motor | |
| c | Date | 14.12.2020 | | = | |
| b | Drawn | M.Zeesh | | + | |
| a | Released | M.Zeesh | | | |
| D | Change | Date | | Name | |
| wiring diagram | | | | Blower STC+SC2 | |
| control voltage | | | | control voltage | |
| KAESER KOMPRESSOREN | | | | SX8.STC-U3010.02 | |
| SX8.STC-U3020.06 | | | | page 3 | |
| | | | | 13 Sht | |

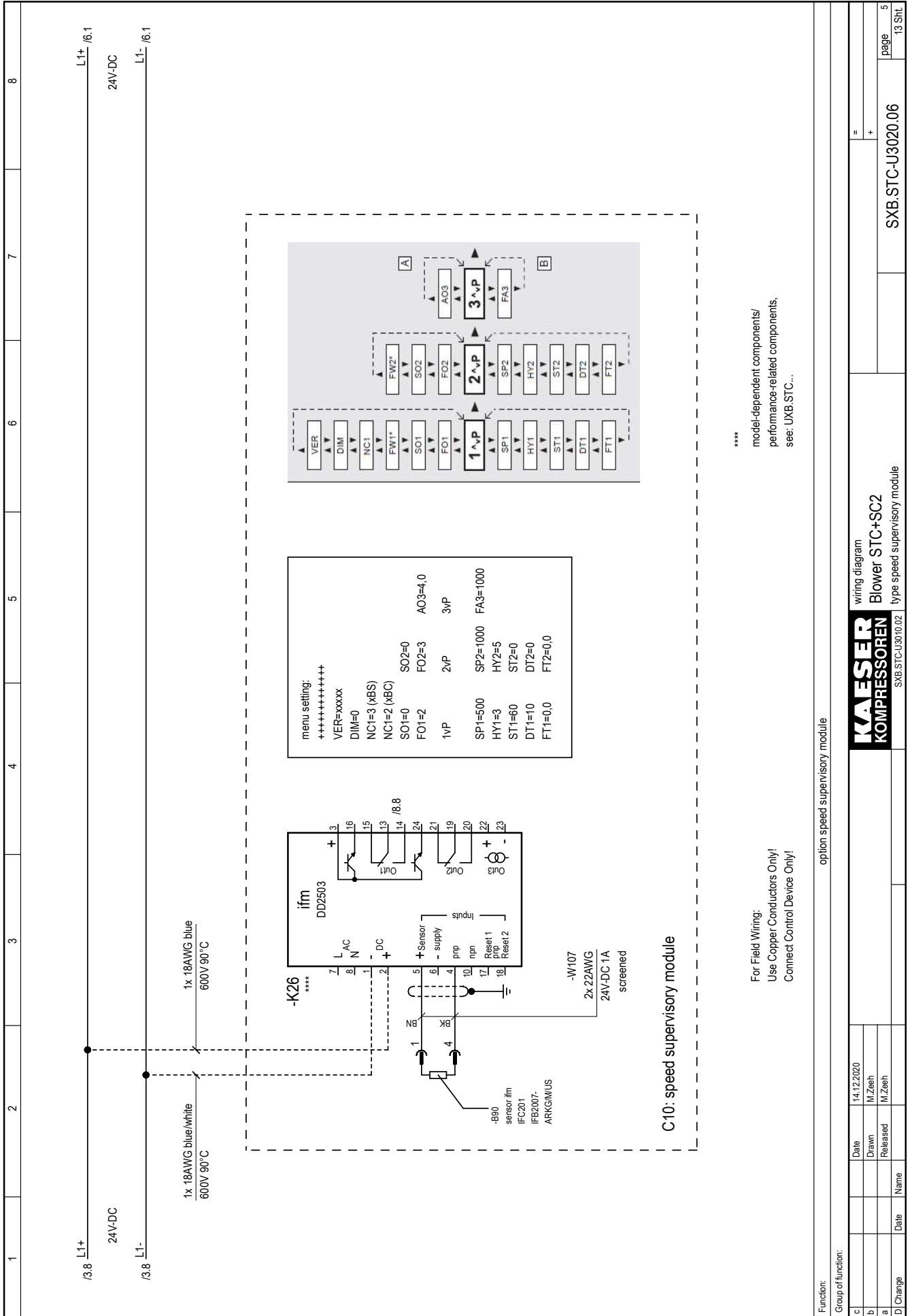

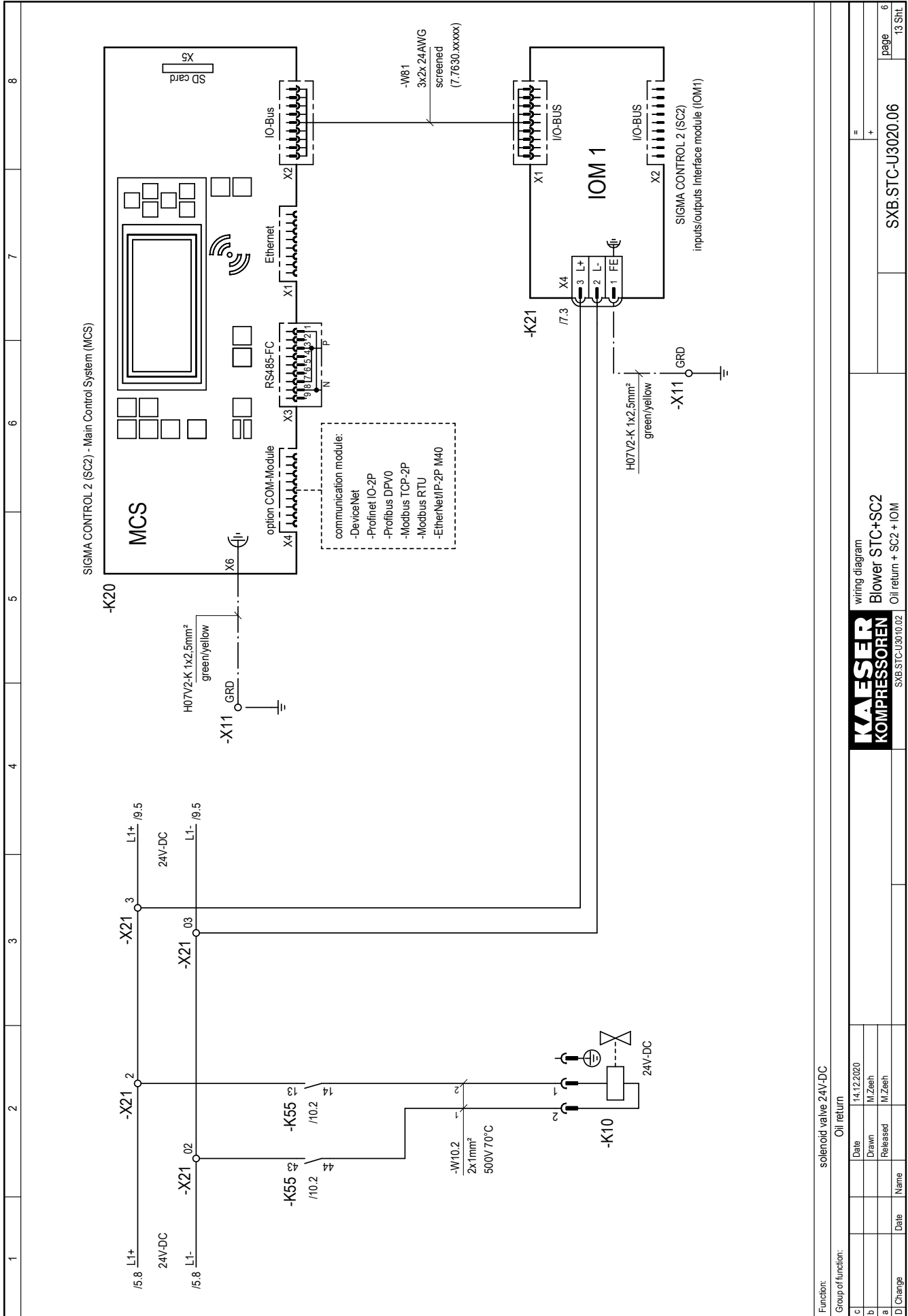

| | | | |
|------------------------|----------|-----------------------|------|
| Function: | | solenoid valve 24V-DC | |
| Group of function: | | Oil return | |
| c | Date | 14.12.2020 | |
| b | Drawn | M.Zeesh | |
| a | Released | M.Zeesh | |
| D | Change | Date | Name |
| wiring diagram | | Blower STC+SC2 | |
| Oil return + SC2 + IOM | | SX8.STC-U3020.06 | |
| | | page | 6 |
| | | 13 Sht | |

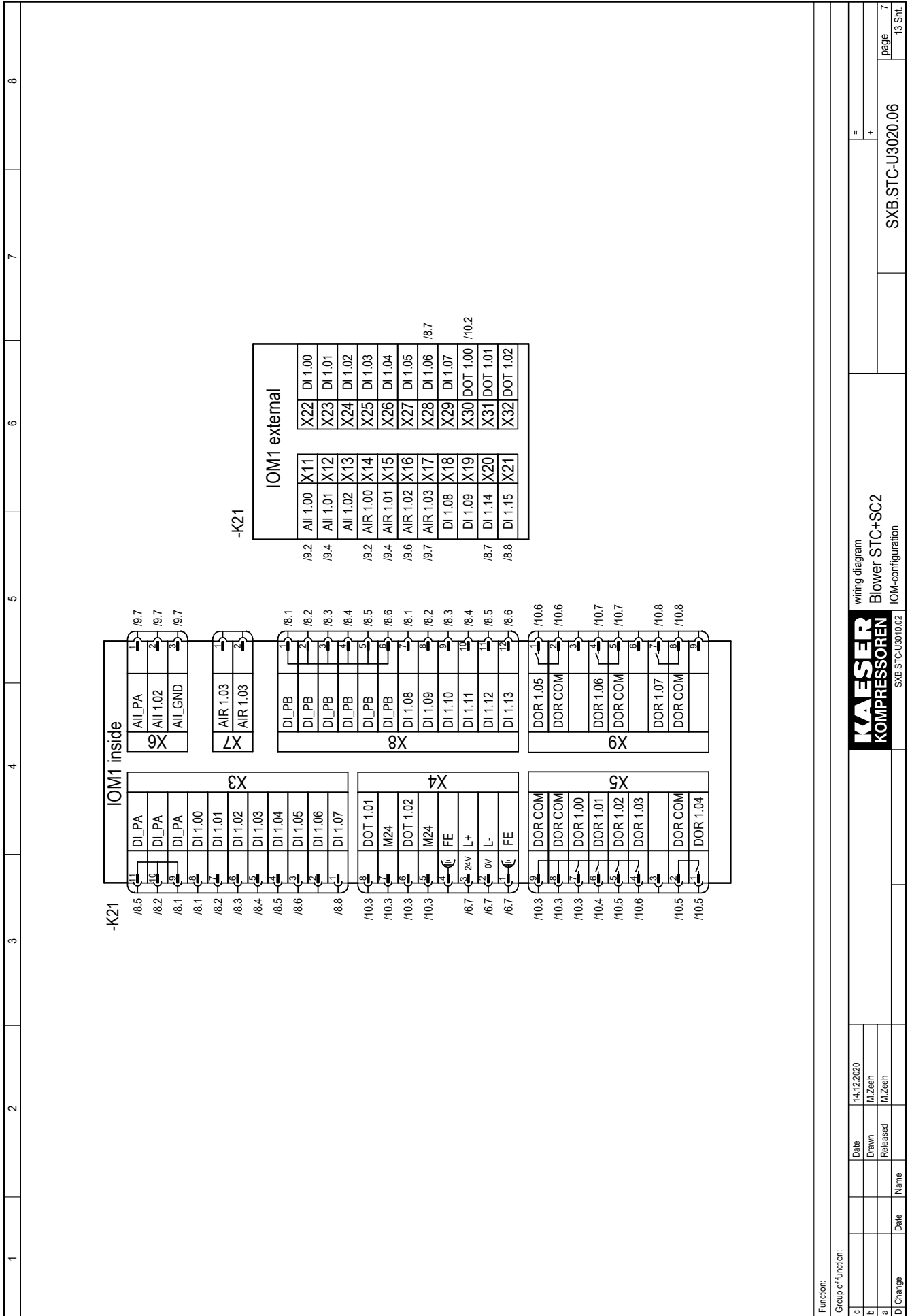

Function:

Group of function:

| | | |
|---|----------|------------|
| c | Date | 14.12.2020 |
| b | Drawn | M.Zeesh |
| a | Released | M.Zeesh |
| D | Change | Date Name |

KAESER
KOMPRESSOREN

wiring diagram
Blower STC+SC2
IOM-configuration

SXB.STC-U3020.06

page 7
13 Sht

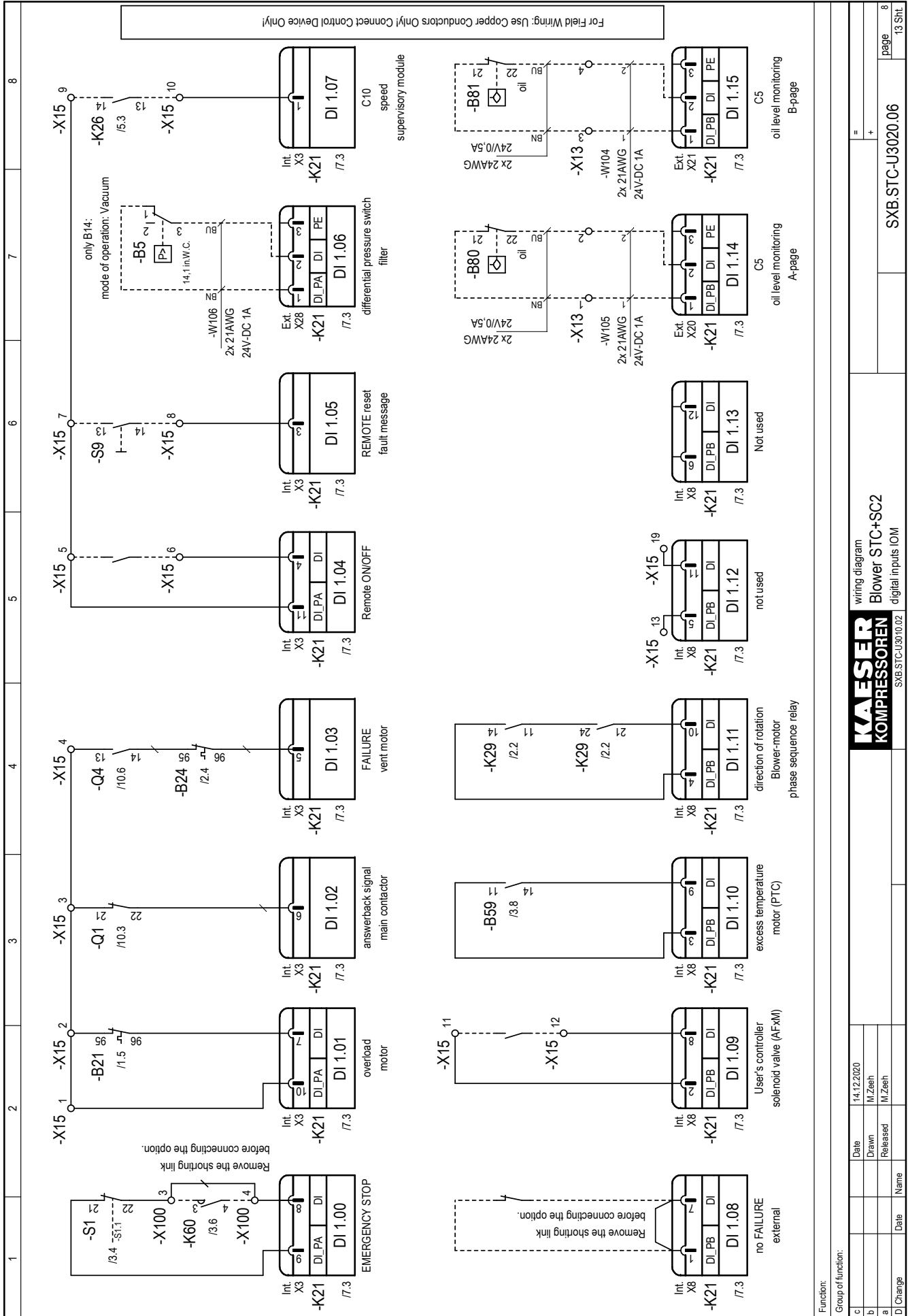

| | | | |
|--------------------|----------|------------------|--------|
| Function: | | wiring diagram | |
| Group of function: | | Blower STC+SC2 | |
| c | Date | 14.12.2020 | page 8 |
| b | Drawn | M.Zeeh | 13 Sht |
| a | Released | M.Zeeh | |
| d | Change | Date | Name |
| | | SX8-STC-U3020.06 | |

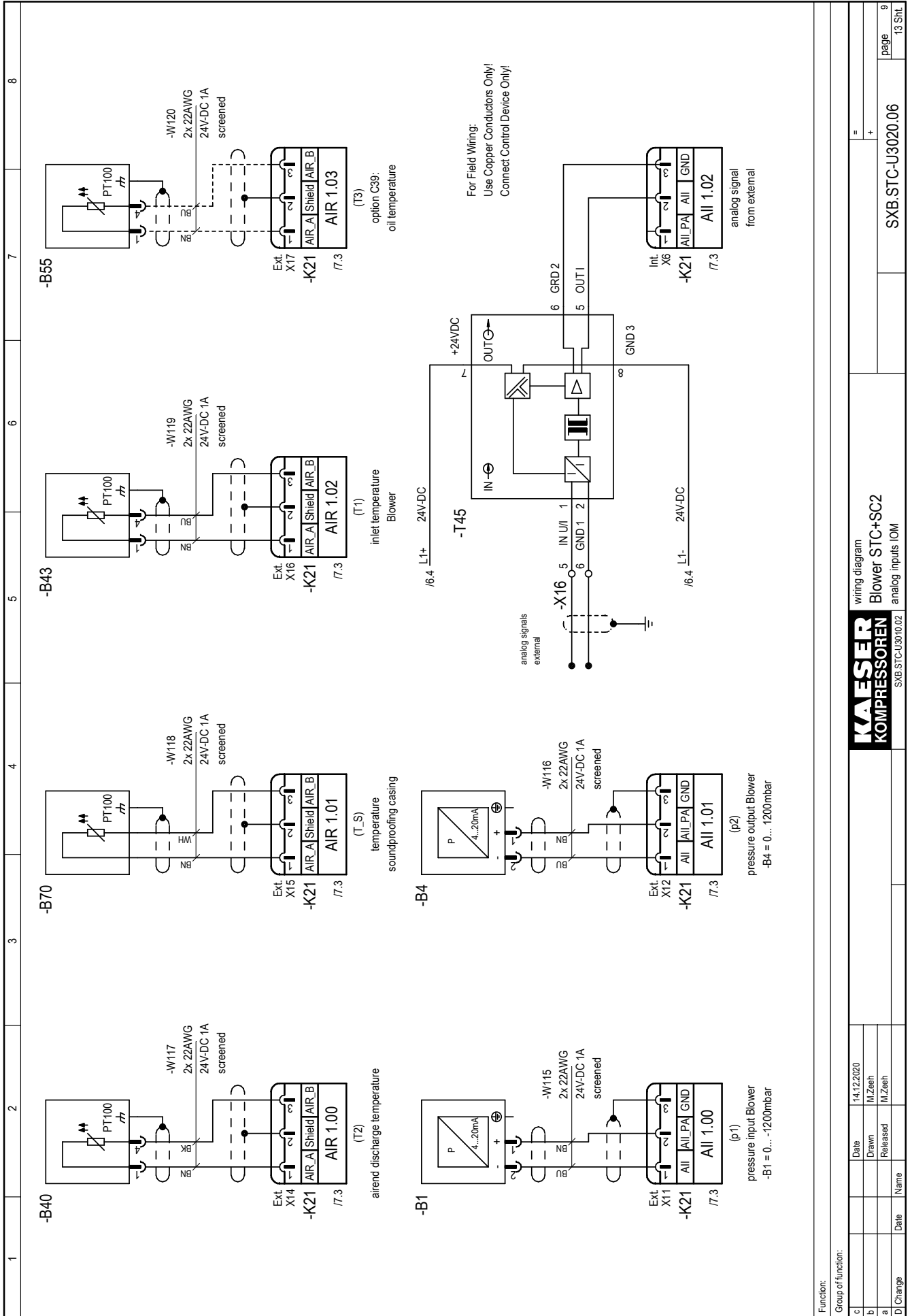

| | | | |
|--------------------|----------|------------------|------|
| Function: | | | |
| Group of function: | | | |
| c | Date | 14.12.2020 | |
| b | Drawn | M.Zeß | |
| a | Released | M.Zeß | |
| D | Change | Date | Name |
| wiring diagram | | = | |
| Blower STC+SC2 | | + | |
| analog inputs IOM | | SX8-STC-U3020.06 | |
| | | page 9 | |
| | | 13 Sht | |

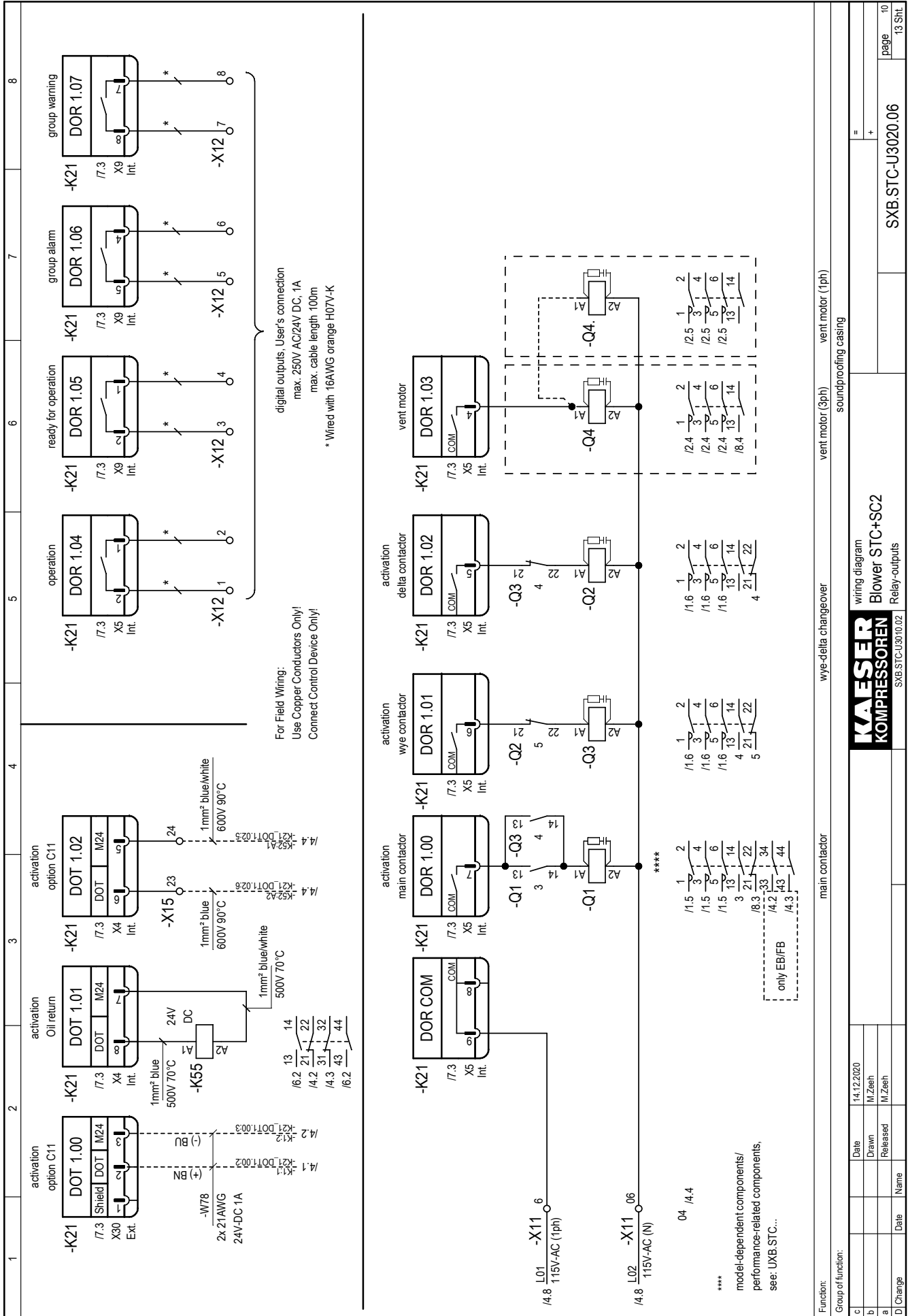

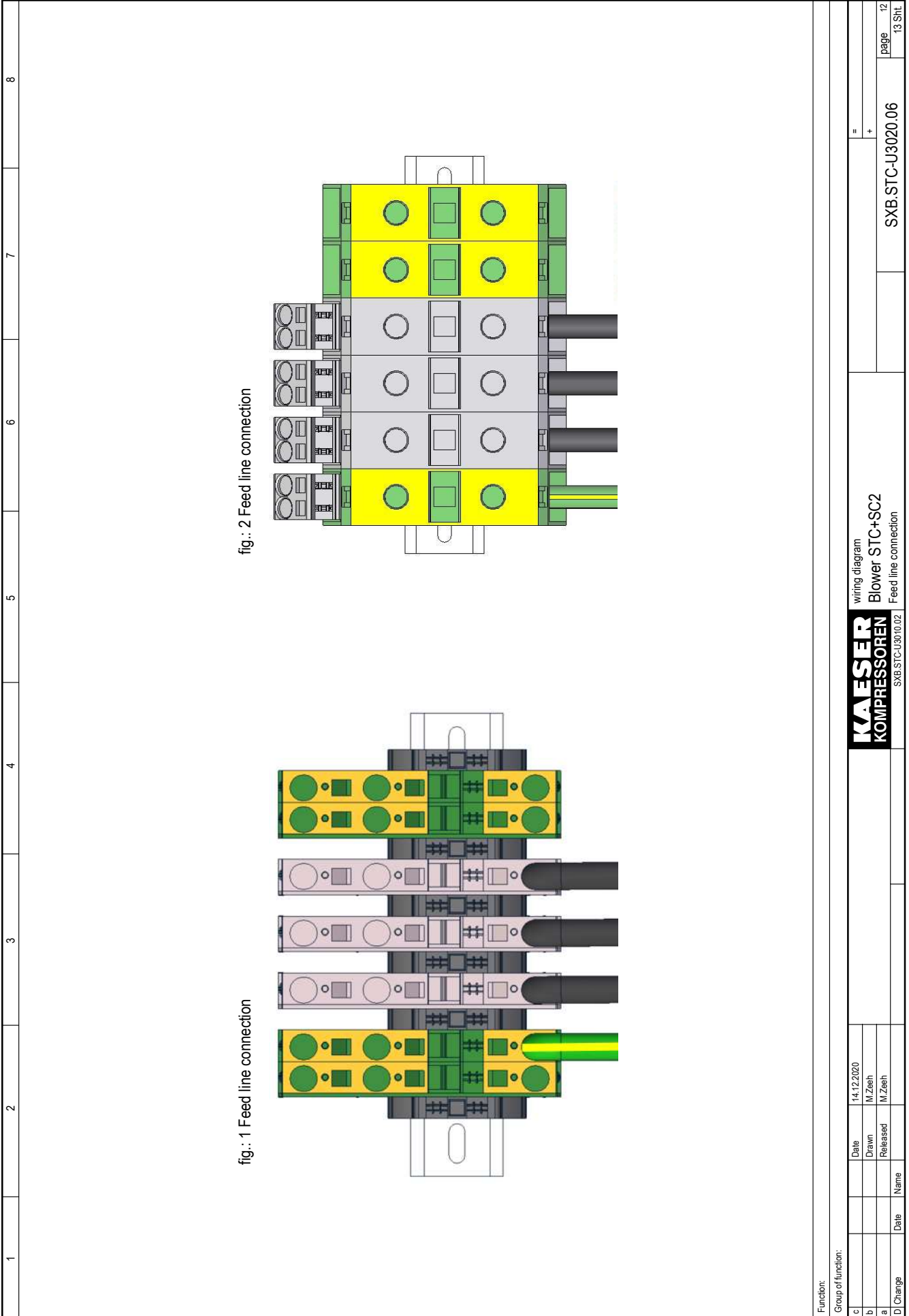

| | | | |
|--------------------|----------|----------------------|------|
| Function: | | | |
| Group of function: | | | |
| c | Date | 14.12.2020 | |
| b | Drawn | M.Zeesh | |
| a | Released | M.Zeesh | |
| D | Change | Date | Name |
| | | wiring diagram | |
| | | Blower STC+SC2 | |
| | | Feed line connection | |
| | | SX.B.STC-U3010.02 | |
| | | SX.B.STC-U3020.06 | |
| | | = | |
| | | + | |
| | | page | |
| | | 12 | |
| | | 13 Sht | |

1 2 3 4 5 6 7 8

fig.: 3 Feed line connection

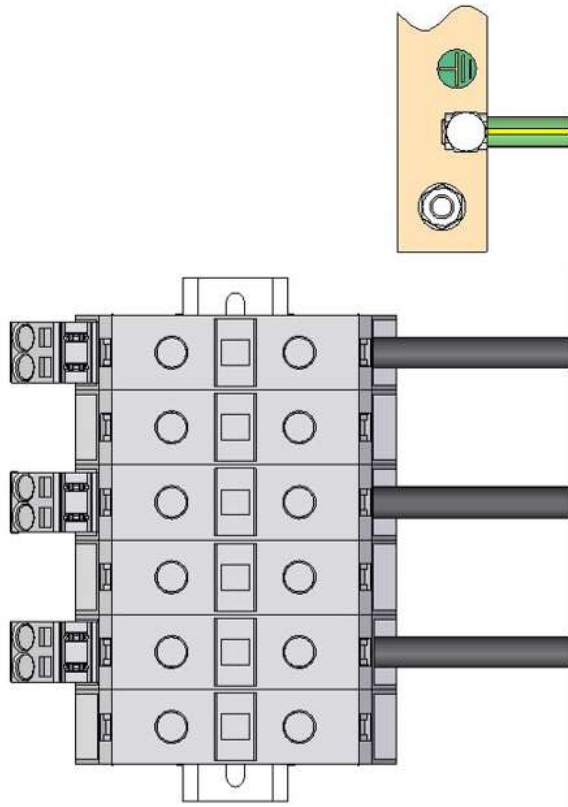

| | | | | | | | | | | | |
|---|----------|------------|----------|---------|--|--|--|--|--|---------------------------|--|
| Function: | | | | | | | | | | | |
| Group of function: | | | | | | | | | | | |
| c | Date | 14.12.2020 | Drawn | M.Zeesh | | | | | | | |
| b | Released | | Released | M.Zeesh | | | | | | | |
| a | Date | | Name | | | | | | | | |
| D | Change | | | | | | | | | | |
| <p>KAESER KOMPRESSOREN SXB.STC-U3010.02</p> <p>wiring diagram Blower STC+SC2 Feed line connection</p> | | | | | | | | | | <p>SXB.STC-U3020.06</p> | |
| | | | | | | | | | | <p>page 13 13 Sht</p> | |

| cable-no. | destination | terminal strip | connection | name of device | terminal-no. | link | terminal legend | jumper wire | location | name of device | connection | destination | cable-no. |
|-----------|-------------|----------------|------------|----------------|--------------|------|-----------------|-------------|----------|----------------|------------|-------------|-----------|
| | | | | | 1 | • | | | /8,2 | -K21-X3 | | | |
| | | | | | 2 | • | | | /8,2 | -B21 | | | |
| | | | | | 3 | • | | | /8,3 | -Q1 | | | |
| | | | | | 4 | • | | | /8,4 | -Q4 | | | |
| | | | | | 5 | • | | | /8,5 | -K21-X3 | | | |
| | | | | | 6 | • | | | /8,5 | -K21-X3 | | | |
| | | | | | 7 | • | | | /8,6 | -S9 | | | |
| | | | | | 8 | • | | | /8,6 | -S9 | | | |
| | | | | | 9 | • | | | /8,8 | -K26 | | | |
| | | | | | 10 | • | | | /8,8 | -K21-X3 | | | |
| | | | | | 11 | • | | | /8,8 | -K21-X8 | | | |
| | | | | | 12 | • | | | /8,2 | -K21-X8 | | | |
| | | | | | 13 | • | | | /8,2 | -K21-X8 | | | |
| | | | | | 14 | • | | | /8,5 | -K21-X8 | | | |
| | | | | | 15 | • | | | /8,5 | -K21-X8 | | | |
| | | | | | 16 | • | | | /8,5 | -K21-X8 | | | |
| | | | | | 17 | • | | | /8,5 | -K21-X8 | | | |
| | | | | | 18 | • | | | /8,5 | -K21-X8 | | | |
| | | | | | 19 | • | | | /8,5 | -K21-X8 | | | |
| | | | | | 20 | • | | | /8,5 | -K21-X8 | | | |
| | | | | | 21 | • | | | /3,6 | -B59 | | | |
| | | | | | 22 | • | | | /3,7 | -B59 | | | |
| | | | | | 23 | • | | | /10,3 | -K21-X4 | | | |
| | | | | | 24 | • | | | /10,4 | -K21-X4 | | | |
| | | | | | A1 | • | | | /8,6 | -GRD | | | |
| | | | | | A2 | • | | | /8,6 | -GRD | | | |
| | | | | | 1 | • | | | /3,8 | -T21 | | | |
| | | | | | 2 | • | | | /3,8 | -T21 | | | |
| | | | | | 3 | • | | | /6,2 | -K55 | | | |
| | | | | | 4 | • | | | /6,2 | -K55 | | | |
| | | | | | 5 | • | | | /6,2 | -K55 | | | |
| | | | | | 6 | • | | | /6,2 | -K55 | | | |
| | | | | | 7 | • | | | /6,3 | -K21-X4 | | | |
| | | | | | 8 | • | | | /6,3 | -K21-X4 | | | |
| | | | | | 9 | • | | | /6,3 | -K21-X4 | | | |
| | | | | | 10 | • | | | /6,3 | -K21-X4 | | | |
| | | | | | 11 | • | | | /3,8 | -T21 | | | |
| | | | | | 12 | • | | | /3,8 | -T21 | | | |
| | | | | | 13 | • | | | /6,2 | -K55 | | | |
| | | | | | 14 | • | | | /6,2 | -K55 | | | |
| | | | | | 15 | • | | | /6,2 | -K55 | | | |
| | | | | | 16 | • | | | /6,2 | -K55 | | | |
| | | | | | 17 | • | | | /6,2 | -K55 | | | |
| | | | | | 18 | • | | | /6,3 | -K21-X4 | | | |
| | | | | | 19 | • | | | /6,3 | -K21-X4 | | | |
| | | | | | 20 | • | | | /6,3 | -K21-X4 | | | |
| | | | | | 21 | • | | | /6,3 | -K21-X4 | | | |
| | | | | | 22 | • | | | /6,3 | -K21-X4 | | | |
| | | | | | 23 | • | | | /6,3 | -K21-X4 | | | |
| | | | | | 24 | • | | | /6,3 | -K21-X4 | | | |
| | | | | | 01 | • | | | /3,5 | -X11 | | | |
| | | | | | 2 | • | | | /3,5 | -S1 | | | |
| | | | | | 3 | • | | | /8,1 | -S1 | | | |
| | | | | | 4 | • | | | /8,1 | -K21-X3 | | | |
| | | | | | 5 | • | | | /8,1 | -K21-X3 | | | |
| | | | | | 6 | • | | | /8,1 | -K21-X3 | | | |

1) class 2 control circuit

| | | | | | | | | |
|---|----------|------------|---------------------|---|---|------------------|--------|---|
| c | Date | 14.12.2020 | terminal connection | = | + | KXB.STC-U3020.06 | page | 2 |
| | Drawn | M.Zeesh | | | | | 2 Sht. | |
| b | Released | | | | | | | |
| a | Name | | | | | | | |
| H | Date | | | | | | | |

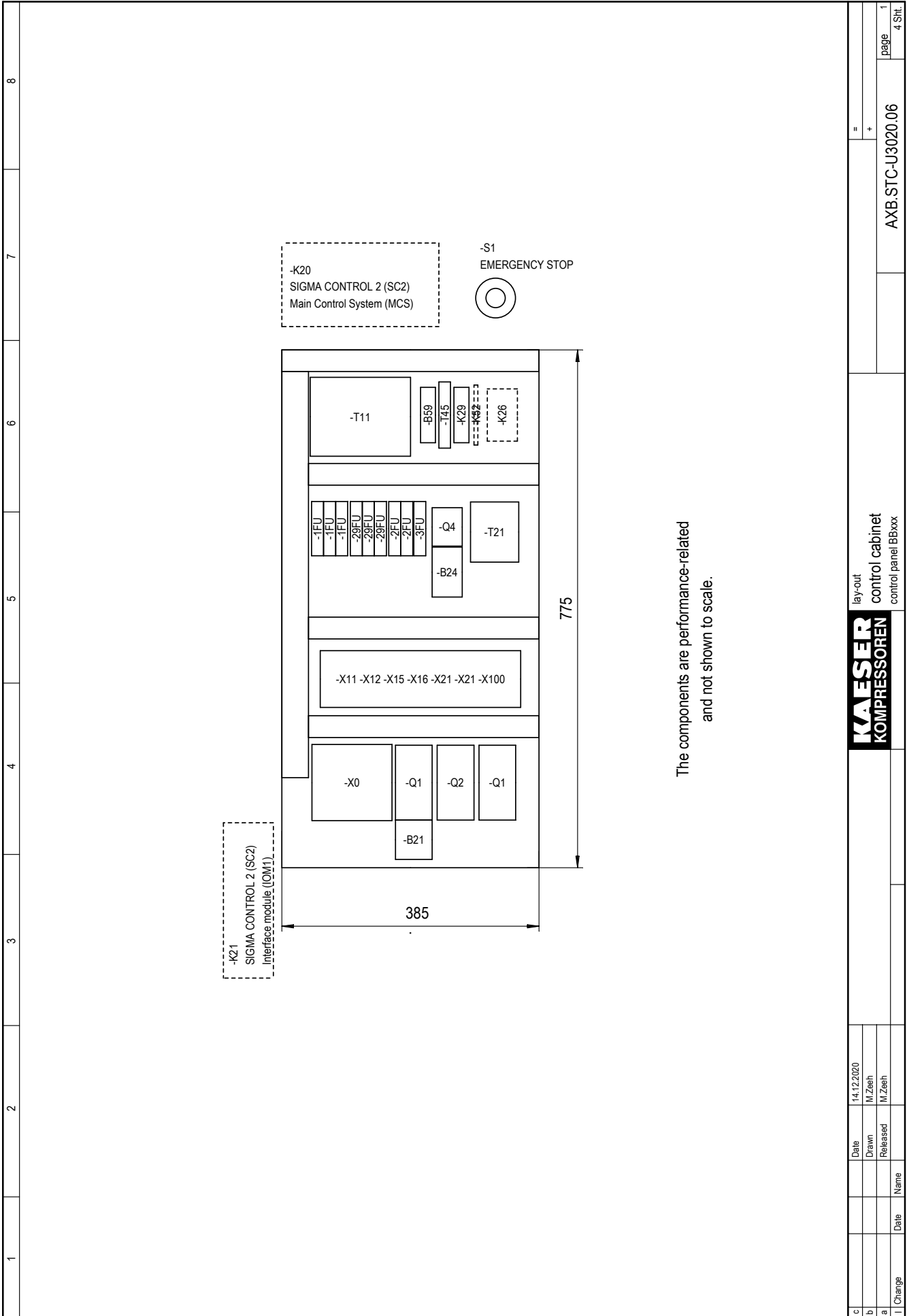

| | | | | | | | |
|---|----------|------------|---------------|-----------------|------------------|------|--------|
| c | Date | 14.12.2020 | lay-out | control cabinet | AXB.STC-U3020.06 | page | 1 |
| b | Drawn | M.Zeeth | control panel | BBxxx | | | |
| a | Released | M.Zeeth | | | | | |
| I | Change | Date | Name | | | | 4 Sht. |

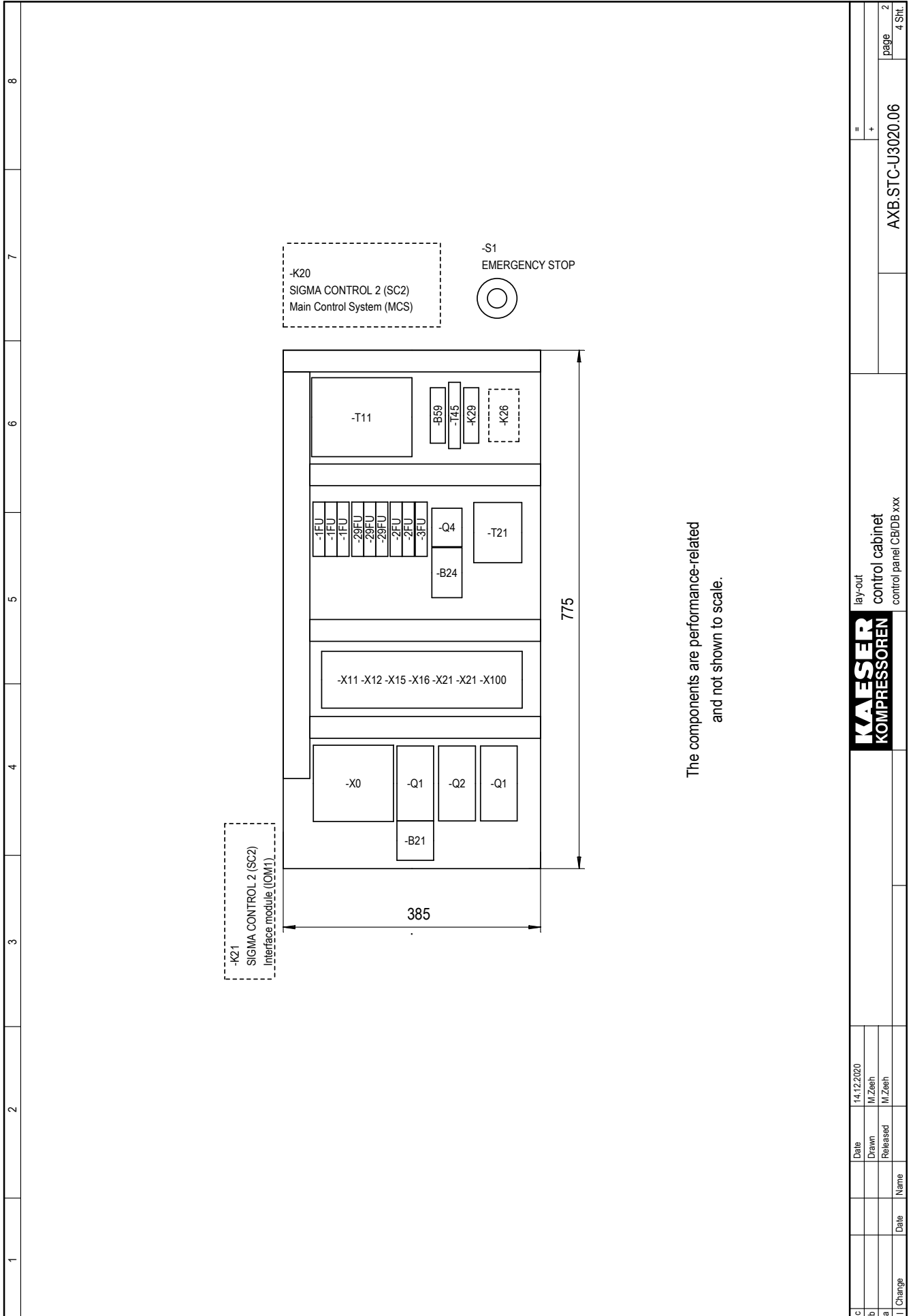

| | | | |
|----------|--|---|------|
| Date | | 14.12.2020 | |
| Drawn | | M.Zeesh | |
| Released | | M.Zeesh | |
| I Change | | Date | Name |
| | | | |
| | | lay-out control cabinet control panel CB/DB xxx | |
| | | AXB.STC-U3020.06 | |
| | | = + | |
| | | page 2 | |
| | | 4 Sht. | |

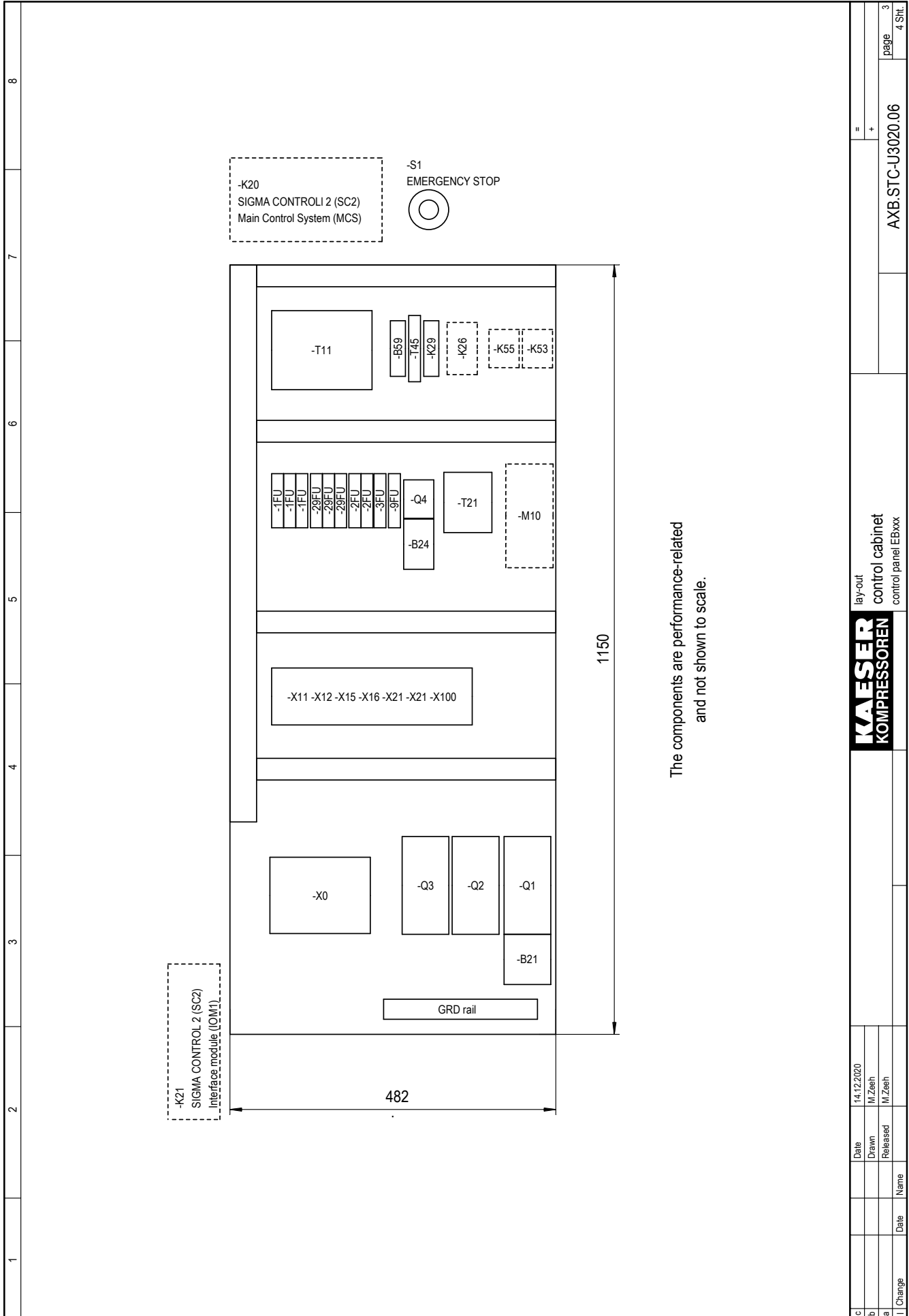

| | | | |
|----------|--|---|------|
| Date | | 14.12.2020 | |
| Drawn | | M.Zeesh | |
| Released | | M.Zeesh | |
| I Change | | Date | Name |
| | | | |
| | | lay-out control cabinet control panel EBxxx | |
| | | AXB.STC-U3020.06 | |
| | | = | + |
| | | page | 3 |
| | | 4 Sht. | |

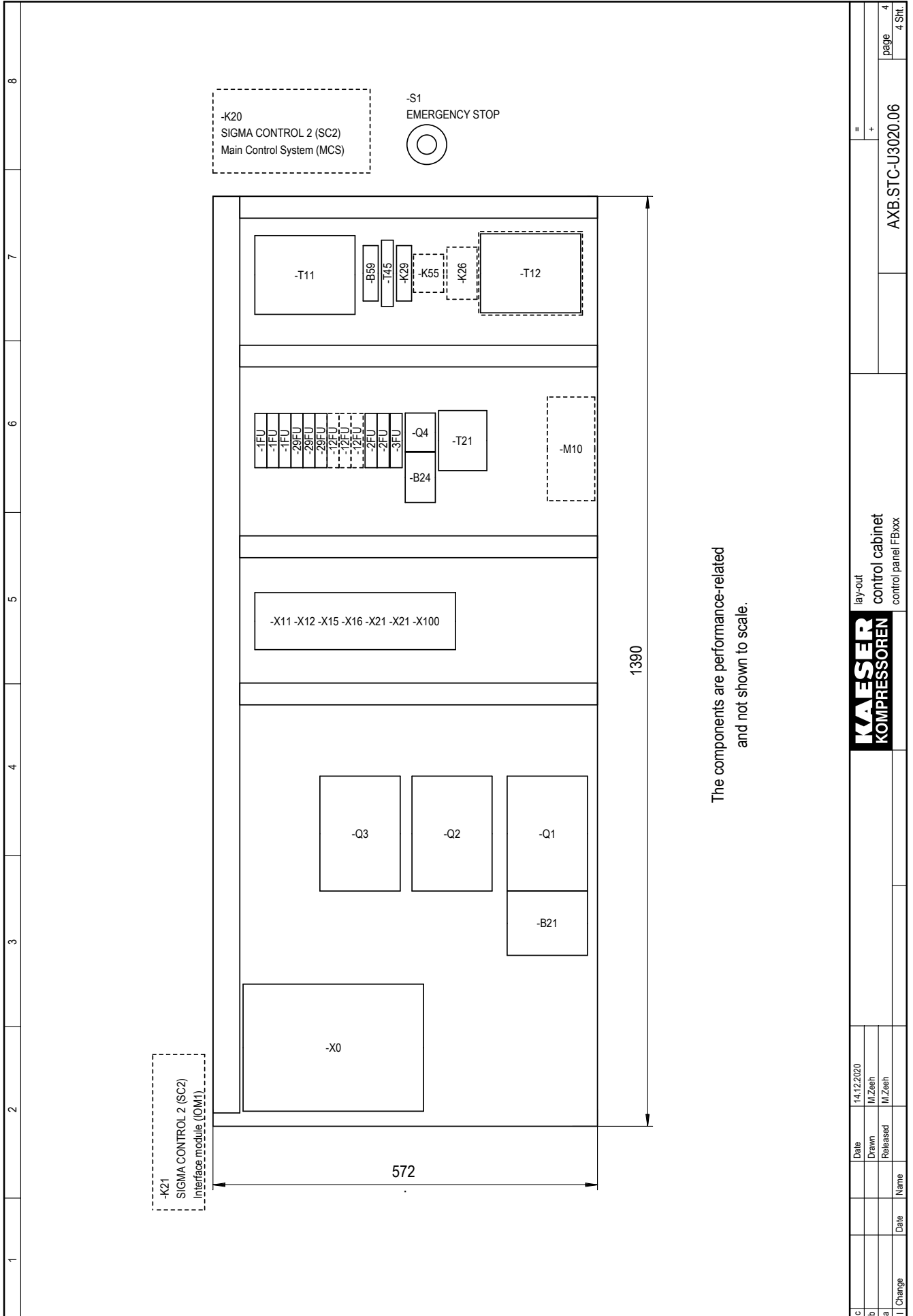

The components are performance-related and not shown to scale.

| | | | | | |
|----------|------|-----------------|--|---------------------|--------|
| = | | + | | AXB.STC-U3020.06 | page 4 |
| lay-out | | control cabinet | | control panel FBxxx | |
| Date | | 14.12.2020 | | | |
| Drawn | | M.Zeesh | | | |
| Released | | M.Zeesh | | | |
| I Change | Date | Name | | | |

13.4.2 Option C34, OMEGA FREQUENCY CONTROL (OFC)

| | | | | | | | | | | | | | | | | | | | | | | | | | | | | | | | | | | | | | | | | | | | | | | | | | | | | | | | | | | | | | | | | | | | | | | | | | | | | | | | | | | | | | | | | | | | | | | | | | | | | | | | |
|---|------------|------------|-----|------------------|------------|---|---|--|-------|------------|-----|--|--|--|--|---|------------|--------|--|--|--|--|--|---|---------|--------|--|--|--|--|--|---|------|--|--|--|--|--|--|---|-------|--|--|---------------|--|--|--|--|--|--|--|-------------|--|--|--|--|--|--|--|--------------|------------|--|--|--|--|--|--|----------------|--|--|--|--|--|--|--|---|--|--|--|--|--|--|--|---|--|--|--|--|--|--|--|------------------|------|---|--|--|--|--|--|-------|--|--|--|
| 1 | 2 | 3 | 4 | 5 | 6 | 7 | 8 | | | | | | | | | | | | | | | | | | | | | | | | | | | | | | | | | | | | | | | | | | | | | | | | | | | | | | | | | | | | | | | | | | | | | | | | | | | | | | | | | | | | | | | | | | | | | | | | |
| <div style="border: 1px solid black; padding: 20px; margin: 10px auto; width: 80%;"> <p style="font-size: 1.2em; margin: 0;">Wiring Diagram</p> <p style="font-size: 1.2em; margin: 0;">Blower with frequency converter</p> <p style="margin: 0;">Siemens Sinamics G120 PM240-2 + SIGMA CONTROL 2 (SC2)</p> <p style="margin: 0;">460V ±10% 3ph 60Hz 5hp-175hp (4kW-132kW)</p> <p style="margin: 0;">Power supply: WYE system with center point solidly grounded</p> </div> | | | | | | | | | | | | | | | | | | | | | | | | | | | | | | | | | | | | | | | | | | | | | | | | | | | | | | | | | | | | | | | | | | | | | | | | | | | | | | | | | | | | | | | | | | | | | | | | | | | | | | | |
| <p style="margin: 0;">ATTENTION !!! The document gives collective information on power supply voltages and frequencies for all machines. The voltage and frequency and local conditions under which any particular machine may be used are given on the nameplate of the machine and in the accompanying service manual.</p> | | | | | | | | | | | | | | | | | | | | | | | | | | | | | | | | | | | | | | | | | | | | | | | | | | | | | | | | | | | | | | | | | | | | | | | | | | | | | | | | | | | | | | | | | | | | | | | | | | | | | | | |
| <p style="margin: 0;">The drawings remain our exclusive property. They are entrusted only for the agreed purpose. Copies or any other reproductions, including storage, treatment and dissemination by use of electronic systems must not be made for any other than the agreed purpose. Neither originals nor reproductions must be forwarded or otherwise made accessible to third parties.</p> | | | | | | | | | | | | | | | | | | | | | | | | | | | | | | | | | | | | | | | | | | | | | | | | | | | | | | | | | | | | | | | | | | | | | | | | | | | | | | | | | | | | | | | | | | | | | | | | | | | | | | | |
| <p>manufacturer: KAESER KOMPRESSOREN SE Postfach 2143 96410 Coburg</p> | | | | | | | | | | | | | | | | | | | | | | | | | | | | | | | | | | | | | | | | | | | | | | | | | | | | | | | | | | | | | | | | | | | | | | | | | | | | | | | | | | | | | | | | | | | | | | | | | | | | | | | |
| <table border="1" style="width: 100%; border-collapse: collapse;"> <tr> <td style="width: 10%;"></td> <td style="width: 10%; text-align: center;">Datum</td> <td style="width: 10%; text-align: center;">05.02.2018</td> <td style="width: 10%; text-align: center;">USE</td> <td colspan="4"></td> </tr> <tr> <td style="text-align: center;">c</td> <td style="text-align: center;">Bearbeiter</td> <td style="text-align: center;">M.Zeeh</td> <td></td> <td colspan="4"></td> </tr> <tr> <td style="text-align: center;">b</td> <td style="text-align: center;">Geprüft</td> <td style="text-align: center;">M.Zeeh</td> <td></td> <td colspan="4"></td> </tr> <tr> <td style="text-align: center;">a</td> <td style="text-align: center;">Name</td> <td></td> <td></td> <td colspan="4"></td> </tr> <tr> <td style="text-align: center;">A</td> <td style="text-align: center;">Datum</td> <td></td> <td></td> <td style="text-align: center;">Ersatz durch:</td> <td colspan="3"></td> </tr> <tr> <td colspan="4"></td> <td style="text-align: center;">Ersatz für:</td> <td colspan="3"></td> </tr> <tr> <td colspan="4"></td> <td style="text-align: center;">KOMPRESSOREN</td> <td colspan="3" style="text-align: center;">cover page</td> </tr> <tr> <td colspan="4"></td> <td style="text-align: center;">Blower xFC+SC2</td> <td colspan="3"></td> </tr> <tr> <td colspan="4"></td> <td style="text-align: center;">=</td> <td colspan="3"></td> </tr> <tr> <td colspan="4"></td> <td style="text-align: center;">+</td> <td colspan="3"></td> </tr> <tr> <td colspan="4"></td> <td style="text-align: center;">DXB.XFC-U3020.04</td> <td style="text-align: center;">page</td> <td colspan="2" style="text-align: center;">1</td> </tr> <tr> <td colspan="4"></td> <td style="text-align: center;">1 Bl.</td> <td colspan="3"></td> </tr> </table> | | | | | | | | | Datum | 05.02.2018 | USE | | | | | c | Bearbeiter | M.Zeeh | | | | | | b | Geprüft | M.Zeeh | | | | | | a | Name | | | | | | | A | Datum | | | Ersatz durch: | | | | | | | | Ersatz für: | | | | | | | | KOMPRESSOREN | cover page | | | | | | | Blower xFC+SC2 | | | | | | | | = | | | | | | | | + | | | | | | | | DXB.XFC-U3020.04 | page | 1 | | | | | | 1 Bl. | | | |
| | Datum | 05.02.2018 | USE | | | | | | | | | | | | | | | | | | | | | | | | | | | | | | | | | | | | | | | | | | | | | | | | | | | | | | | | | | | | | | | | | | | | | | | | | | | | | | | | | | | | | | | | | | | | | | | | | | | | |
| c | Bearbeiter | M.Zeeh | | | | | | | | | | | | | | | | | | | | | | | | | | | | | | | | | | | | | | | | | | | | | | | | | | | | | | | | | | | | | | | | | | | | | | | | | | | | | | | | | | | | | | | | | | | | | | | | | | | | | |
| b | Geprüft | M.Zeeh | | | | | | | | | | | | | | | | | | | | | | | | | | | | | | | | | | | | | | | | | | | | | | | | | | | | | | | | | | | | | | | | | | | | | | | | | | | | | | | | | | | | | | | | | | | | | | | | | | | | | |
| a | Name | | | | | | | | | | | | | | | | | | | | | | | | | | | | | | | | | | | | | | | | | | | | | | | | | | | | | | | | | | | | | | | | | | | | | | | | | | | | | | | | | | | | | | | | | | | | | | | | | | | | | | |
| A | Datum | | | Ersatz durch: | | | | | | | | | | | | | | | | | | | | | | | | | | | | | | | | | | | | | | | | | | | | | | | | | | | | | | | | | | | | | | | | | | | | | | | | | | | | | | | | | | | | | | | | | | | | | | | | | | | |
| | | | | Ersatz für: | | | | | | | | | | | | | | | | | | | | | | | | | | | | | | | | | | | | | | | | | | | | | | | | | | | | | | | | | | | | | | | | | | | | | | | | | | | | | | | | | | | | | | | | | | | | | | | | | | | |
| | | | | KOMPRESSOREN | cover page | | | | | | | | | | | | | | | | | | | | | | | | | | | | | | | | | | | | | | | | | | | | | | | | | | | | | | | | | | | | | | | | | | | | | | | | | | | | | | | | | | | | | | | | | | | | | | | | | | |
| | | | | Blower xFC+SC2 | | | | | | | | | | | | | | | | | | | | | | | | | | | | | | | | | | | | | | | | | | | | | | | | | | | | | | | | | | | | | | | | | | | | | | | | | | | | | | | | | | | | | | | | | | | | | | | | | | | |
| | | | | = | | | | | | | | | | | | | | | | | | | | | | | | | | | | | | | | | | | | | | | | | | | | | | | | | | | | | | | | | | | | | | | | | | | | | | | | | | | | | | | | | | | | | | | | | | | | | | | | | | | |
| | | | | + | | | | | | | | | | | | | | | | | | | | | | | | | | | | | | | | | | | | | | | | | | | | | | | | | | | | | | | | | | | | | | | | | | | | | | | | | | | | | | | | | | | | | | | | | | | | | | | | | | | |
| | | | | DXB.XFC-U3020.04 | page | 1 | | | | | | | | | | | | | | | | | | | | | | | | | | | | | | | | | | | | | | | | | | | | | | | | | | | | | | | | | | | | | | | | | | | | | | | | | | | | | | | | | | | | | | | | | | | | | | | | | |
| | | | | 1 Bl. | | | | | | | | | | | | | | | | | | | | | | | | | | | | | | | | | | | | | | | | | | | | | | | | | | | | | | | | | | | | | | | | | | | | | | | | | | | | | | | | | | | | | | | | | | | | | | | | | | | |

| Common parts | | 5 - 175 hp / 4 - 132 kW | | = + | | UXB.XFC-U3020.04 | | page 3 | | 11 Bl. | |
|------------------------------|---|--|------------|-----|--|------------------|--|--------|--|--------|--|
| model | | | | | | | | | | | |
| machine power supply | | 460 V ±10 %, 60 Hz | | | | | | | | | |
| pressure transducer | -B1 Huba Control | 894786.0 0.-1200mbar | | | | | | | | | |
| pressure transducer | -B4 Huba Control | 894787.0 0.1200mbar | | | | | | | | | |
| differential pressure switch | -B5 Dungs | 893307.00010 setting: 14,1 in.W.C. | | | | | | | | | |
| temperature probe | -B40/-B43 WIKA | 895251.10010 (BB/CB/DB) 895251.10040 (EB-C/FB) 895603.00040 (EB-S) Pt100 | | | | | | | | | |
| temperature probe | -B55 | 895251.10100 895603.00100 (EB-S) Pt100 | | | | | | | | | |
| temperature probe | -B70 Wieland | 7.7631.0-P21 PT100 | | | | | | | | | |
| fuse | -1FU Gould | (3x) - 7.3161.00190 ATQR 8 A - 600 V - class CC | | | | | | | | | |
| fuse | -2FU Gould | (2x) - 7.3317.1 ATQR 3 A - 600 V - class CC | | | | | | | | | |
| fuse | -3FU Gould | (1x) - 7.3161.00160 ATQR 5 A - 600 V - class CC | | | | | | | | | |
| fuse | -8FU Gould | (1x) - 7.3304.00010 ATDR 2 A - 600 V - class CC | | | | | | | | | |
| fuse | -10FU | 895637.0 5x20 0,315 A-T 250 VAC | | | | | | | | | |
| fuse | -29FU Gould | (3x) - 7.3161.00360 ATDR 1 A - 600 V - class CC | | | | | | | | | |
| fuse socket | -1FU/-29FU -2FU -3FU/-8FU Wöhner | 3-pole (2x) - 7.3320.00060 2-pole (1x) - 7.3320.00070 1-pole (2x) - 7.3320.00050 class CC - Ambus Easy Switch | | | | | | | | | |
| solenoid valve | -K10 bükert | 895601.0 24V-DC 8W | | | | | | | | | |
| Blower control | -K20 Prodrive | 7.7601.0 SC2MCS | | | | | | | | | |
| Blower control | -K21 Prodrive | 7.7602.1 SC2IOM-1 | | | | | | | | | |
| phase sequence relay | -K29 Siemens | 7.7830.00600 3UG4615 | | | | | | | | | |
| coupling relay | -K50/-K51 Wieland | 7.3149.00660 24DC-1W-250V6A | | | | | | | | | |
| coupling relay | -K55 Siemens | 7.8740.04210 3RH2122-1JB40 DC 17-30 V AC-15: 230 V/10 A | | | | | | | | | |
| vacuum pump | -M10 Schwarzer | 895612.00100 24V-AC 60 Hz, 4W | | | | | | | | | |
| Fortsetzung: nächstes Blatt | | | | | | | | | | | |
| c | | | | | | | | | | | |
| b | | | | | | | | | | | |
| a | | | | | | | | | | | |
| C-Änderung | | | | | | | | | | | |
| | | Datum | 05.02.2018 | | | | | | | | |
| | | Bearbeiter | M.Zeeh | | | | | | | | |
| | | Geprüft | IM/Zeeh | | | | | | | | |
| | | Norm | | | | | | | | | |
| | | Name | | | | | | | | | |
| | | Datum | | | | | | | | | |
| | | Ersatz durch: | | | | | | | | | |
| | | Ersatz für: | | | | | | | | | |
| | | electrical component parts list | | | | | | | | | |
| | | Blower xFC+SC2 | | | | | | | | | |
| | | Common parts | | | | | | | | | |
| | | KAESER KOMPRESSOREN | | | | | | | | | |
| | | Ursprung: | | | | | | | | | |

| | | | | | | | |
|-------------------------|--|--|--|---|--|------------------|--|
| model | | Common parts 5 - 175 hp / 4 - 132 kW | | = + | | page 4 11 Bl. | |
| machine power supply | | 460 V ±10 %, 60 Hz | | UXB.XFC-U3020.04 | | | |
| contactor | -Q4 Siemens | 7.8740.00310 3RT2016-1AK61 | | | | | |
| interference suppressor | . | 7.8740.05130 Siemens 3RT2916-1CC00 | | | | | |
| control transformer | -T11 Block | 7.2238.10090 USTE630 - 630 VA 208-600 V/2x 115 V+ 24 V | | | | | |
| power supply | -T21 Prodrive | 7.7605P0 PSDC24/2.5 100-240 V-AC/24 V-DC 2,5 A | | | | | |
| isolating amplifier | -T45 Phoenix | 7.2892.00040 MCR-C-III-00-DC | | | | | |
| control line terminal | -X. 11/12/15/16/21/22/100 Handling | 895635.0 Wieland WTP fig. 1, Sht. 11 | | | | | |
| | | | | electrical component parts list Blower xFC+SC2 Common parts | | | |
| | | | | KAESER KOMPRESSOREN | | | |
| | | | | Ursprung: | | | |
| | | | | Ersatz durch: | | Ersatz für: | |
| | | | | Ersatz durch: | | Ersatz für: | |
| c | Datum | 05.02.2018 | | | | | |
| b | Bearbeiter | M.Zeeh | | | | | |
| a | Geprüft | IM.Zeeh | | | | | |
| C-Änderung | Norm | | | | | | |
| | Name | | | | | | |
| | Datum | | | | | | |

| model | performance-related components | | | | | page 6 11 Bl. | | | | | | | | | | | | | | | | | |
|--|--|--|--|--|--|---|-------|------------|---|------------|--------|---|---------|---------|------------|------|--|--|------|--|--|-------|--|
| | 5 hp BB (4 kW) | 7,5 hp BB+ CB+DB (5,5 kW) | 10 hp BB+ CB+DB (7,5 kW) | 15 hp BB+ CB+DB 11 kW) | 20 hp BB+ CB+DB (15 kW) | | | | | | | | | | | | | | | | | | |
| machine power supply | 460 V ±10 %, 60 Hz | 460 V ±10 %, 60 Hz | 460 V ±10 %, 60 Hz | 460 V ±10 %, 60 Hz | 460 V ±10 %, 60 Hz | = + UXB.XFC-U3020.04 | | | | | | | | | | | | | | | | | |
| overload relay soundproofing casing Siemens | -B24 7.8741.00030 3RB3016-1PB0 1,00-4,00 A / S00 setting: 1,43 A NEC 430.32(C) incremental setting: 1,61 A | 7.8741.00030 3RB3016-1PB0 1,00-4,00 A / S00 setting: 1,43 A NEC 430.32(C) incremental setting: 1,61 A | 7.8741.00030 3RB3016-1PB0 1,00-4,00 A / S00 setting: 1,43 A NEC 430.32(C) incremental setting: 1,61 A | 7.8741.00030 3RB3016-1PB0 1,00-4,00 A / S00 setting: 1,43 A NEC 430.32(C) incremental setting: 1,61 A | 7.8741.00030 3RB3016-1PB0 1,00-4,00 A / S00 setting: 1,43 A NEC 430.32(C) incremental setting: 1,61 A | | | | | | | | | | | | | | | | | | |
| Surge protective device Dehn | -F86 7.8669.00020 DG MU 3PY 480 3W+ G | 7.8669.00020 DG MU 3PY 480 3W+ G | 7.8669.00020 DG MU 3PY 480 3W+ G | 7.8669.00020 DG MU 3PY 480 3W+ G | 7.8669.00020 DG MU 3PY 480 3W+ G | electrical component parts list BB+CB+DB performance-related components | | | | | | | | | | | | | | | | | |
| Blower motor Siemens | -M1 894989.0 460 V-D/60 Hz 7 A, 3600U | 894990.0 460 V-D/60 Hz 10,1 A, 3600U | 894991.0 460 V-D/60 Hz 13,2 A, 3600U | 894992.0 460 V-D/60 Hz 20,2 A, 3600U | 895049.0 460 V-D/60 Hz 27,6 A, 3600U | | | | | | | | | | | | | | | | | | |
| vent motor soundproofing casing ebm | -M4 895260.00010 W2D250 115 V/60 Hz (1Ph/N/GRD) 175W 1,55 A | 895260.00010 W2D250 115 V/60 Hz (1Ph/N/GRD) 175W 1,55 A | 895260.00010 W2D250 115 V/60 Hz (1Ph/N/GRD) 175W 1,55 A | 895260.00010 W2D250 115 V/60 Hz (1Ph/N/GRD) 175W 1,55 A | 895260.00010 W2D250 115 V/60 Hz (1Ph/N/GRD) 175W 1,55 A | KAESER KOMPRESSOREN Ursprung: | | | | | | | | | | | | | | | | | |
| vent motor control cabinet Ruebsamen | -M8 / (-M9) 7.2751.00490 LV410 (1Ph/N/GRD) 115 V/60 Hz, 40W 0,5 A | 7.2751.00490 LV410 (1Ph/N/GRD) 115 V/60 Hz, 40W 0,5 A | 7.2751.00490 LV410 (1Ph/N/GRD) 115 V/60 Hz, 40W 0,5 A | 7.2751.00490 LV410 (1Ph/N/GRD) 115 V/60 Hz, 40W 0,5 A | 7.2751.00490 LV410 (1Ph/N/GRD) 115 V/60 Hz, 40W 0,5 A | | | | | | | | | | | | | | | | | | |
| line commutation reactor Siemens | -R1 7.7831.00310 6SL3203-OCE21-8AA0 | 7.7831.00310 6SL3203-OCE21-8AA0 | 7.7831.00310 6SL3203-OCE21-8AA0 | 7.7831.00320 6SL3203-OCE23-8AA0 | 7.7831.00320 6SL3203-OCE23-8AA0 | Ersatz für: Ersatz durch: | | | | | | | | | | | | | | | | | |
| ferrit bead Magnetec | -R3.1 -R3.2 7.8538.0 (M112) 1x 7.8538.0 (M112) | 7.8538.0 (M112) 1x 7.8538.0 (M112) | 7.8538.0 (M112) 1x 7.8538.0 (M112) | 7.8538.0 (M112) 1x 7.8538.0 (M112) | 7.8538.0 (M112) 1x 7.8538.0 (M112) | | | | | | | | | | | | | | | | | | |
| interference suppression filter Siemens | -R11 integrated --- | integrated --- | integrated --- | 7.8832.10030 Schaffner FS33891-50-07 | 7.8832.10030 Schaffner FS33891-50-07 | | | | | | | | | | | | | | | | | | |
| frequency converter control unit instrument panel Siemens | -T1 7.8833.01070 6SL3210-1PE21-1AL0 7.7830.00710 6SL3244-0BB12-1BAx 7.7830.00100 6SL3255-0AA00-4CA1 | 7.8833.01080 6SL3210-1PE21-4AL0 7.7830.00710 6SL3244-0BB12-1BAx 7.7830.00100 6SL3255-0AA00-4CA1 | 7.8833.01090 6SL3210-1PE21-8AL0 7.7830.00710 6SL3244-0BB12-1BAx 7.7830.00100 6SL3255-0AA00-4CA1 | 7.8833.00100 6SL3210-1PE22-7UL0 7.7830.00710 6SL3244-0BB12-1BAx 7.7830.00100 6SL3255-0AA00-4CA1 | 7.8833.00110 6SL3210-1PE23-3UL0 7.7830.00710 6SL3244-0BB12-1BAx 7.7830.00100 6SL3255-0AA00-4CA1 | | | | | | | | | | | | | | | | | | |
| motor cable | -W211 4x10 AWG / 4G6 mm ² 600 V - 80°C - EMV | 4x10 AWG / 4G6 mm ² 600 V - 80°C - EMV | 4x10 AWG / 4G6 mm ² 600 V - 80°C - EMV | 4x8 AWG / 4G10 mm ² 600 V - 80°C - EMV | 4x8 AWG / 4G10 mm ² 600 V - 80°C - EMV | | | | | | | | | | | | | | | | | | |
| connection | -W280.1/2 -W281 -W282 10 AWG / 6 mm ² 10 AWG / 6 mm ² 10 AWG / 6 mm ² 600 V - 90°C | 10 AWG / 6 mm ² 10 AWG / 6 mm ² 10 AWG / 6 mm ² 600 V - 90°C | 10 AWG / 6 mm ² 10 AWG / 6 mm ² 10 AWG / 6 mm ² 600 V - 90°C | 8 AWG / 10 mm ² 8 AWG / 10 mm ² 8 AWG / 10 mm ² 600 V - 90°C | 8 AWG / 10 mm ² 8 AWG / 10 mm ² 8 AWG / 10 mm ² 600 V - 90°C | | | | | | | | | | | | | | | | | | |
| supply terminals supply | -X0: U1/N1/W1/GRD Handling Stripped length X connection 894864.00010 Wieland 14-4 AWG/2,5-16 mm ² fig. 2, Sht. 12 16 mm fig. 1, Sht. 13 | 894864.00010 Wieland 14-4 AWG/2,5-16 mm ² fig. 2, Sht. 12 16 mm fig. 1, Sht. 13 | 894864.00010 Wieland 14-4 AWG/2,5-16 mm ² fig. 2, Sht. 12 16 mm fig. 1, Sht. 13 | 894864.00010 Wieland 14-4 AWG/2,5-16 mm ² fig. 2, Sht. 12 16 mm fig. 1, Sht. 13 | 894864.00010 Wieland 14-4 AWG/2,5-16 mm ² fig. 2, Sht. 12 16 mm fig. 1, Sht. 13 | | | | | | | | | | | | | | | | | | |
| <table border="1"> <tr> <td>c</td> <td>Datum</td> <td>05.02.2018</td> </tr> <tr> <td>b</td> <td>Bearbeiter</td> <td>M.Zeeh</td> </tr> <tr> <td>a</td> <td>Geprüft</td> <td>IM.Zeeh</td> </tr> <tr> <td>C-Änderung</td> <td>Norm</td> <td></td> </tr> <tr> <td></td> <td>Name</td> <td></td> </tr> <tr> <td></td> <td>Datum</td> <td></td> </tr> </table> | | | | | | c | Datum | 05.02.2018 | b | Bearbeiter | M.Zeeh | a | Geprüft | IM.Zeeh | C-Änderung | Norm | | | Name | | | Datum | |
| c | Datum | 05.02.2018 | | | | | | | | | | | | | | | | | | | | | |
| b | Bearbeiter | M.Zeeh | | | | | | | | | | | | | | | | | | | | | |
| a | Geprüft | IM.Zeeh | | | | | | | | | | | | | | | | | | | | | |
| C-Änderung | Norm | | | | | | | | | | | | | | | | | | | | | | |
| | Name | | | | | | | | | | | | | | | | | | | | | | |
| | Datum | | | | | | | | | | | | | | | | | | | | | | |

| model | performance-related components | | | | page 8 11 Bl. |
|---|--|--|---|---|---|
| | 25 hp EB 18,5W) | 30 hp EB (22 kW) | 40 hp EB+ FB-C (30 kW) | 40 hp FB-S (30 kW) | |
| machine power supply | 460 V ±10 %, 60 Hz | 460 V ±10 %, 60 Hz | 460 V ±10 %, 60 Hz | 460 V ±10 %, 60 Hz | = + UXB.XFC-U3020.04 |
| overload relay soundproofing casing Siemens | -B24 7.8741.00020 3RB3016-1NB0 0,32-1,25 A / S00 setting: 0,57 A NEC 430.32(C) incremental setting: 0,64 A | 7.8741.00020 3RB3016-1NB0 0,32-1,25 A / S00 setting: 0,57 A NEC 430.32(C) incremental setting: 0,64 A | 7.8741.00020 3RB3016-1NB0 0,32-1,25 A / S00 setting: 0,57 A NEC 430.32(C) incremental setting: 0,64 A | 7.8741.00020 3RB3016-1NB0 0,32-1,25 A / S00 setting: 0,57 A NEC 430.32(C) incremental setting: 0,64 A | |
| Surge protective device Dehn | -F86 7.8669.00020 DG MU 3PY 480 3W+ G | 7.8669.00020 DG MU 3PY 480 3W+ G | 7.8669.00020 DG MU 3PY 480 3W+ G | 7.8669.00020 DG MU 3PY 480 3W+ G | electrical component parts list EB+FB performance-related components |
| Blower motor Siemens | -M1 894994.0 460 V-D/60 Hz 32,2 A, 3600U | 894995.0 460 V-D/60 Hz 38,5 A, 3600U | 894997.1 460 V-D/60 Hz 52 A, 3600U | 894997.1 460 V-D/60 Hz 52 A, 3600U | |
| vent motor soundproofing casing Sodeca/ebm | -M4 895040.00040 HC-31-2T / H-I-E 460 V-Y/60 Hz (3PH/GRD) 210W 0,62 A | 895040.00040 HC-31-2T / H-I-E 460 V-Y/60 Hz (3PH/GRD) 210W 0,62 A | 895040.00040 HC-31-2T / H-I-E 460 V-Y/60 Hz (3PH/GRD) 210W 0,62 A | 895426.0 W4D420 (ebm) 460 V-Y/60 Hz (3PH/GRD) 265W 0,62 A | KAESER KOMPRESSOREN Ursprung: |
| vent motor control cabinet Ruebsamen | -M8/-M9 7.2751.00360 LV600 (1Ph/N/GRD) 115 V/60 Hz, 80W 0,7 A | 7.2751.00360 LV600 (1Ph/N/GRD) 115 V/60 Hz, 80W 0,7 A | 7.2751.00360 LV600 (1Ph/N/GRD) 115 V/60 Hz, 80W 0,7 A | 7.2751.00360 LV600 (1Ph/N/GRD) 115 V/60 Hz, 80W 0,7 A | |
| line commutation reactor Siemens | -R1 integrated --- | integrated --- | integrated --- | integrated --- | Ersatz für: |
| ferrit bead Magnetec | -R3.1 -R3.2 7.8538.0 (M112) 1x 7.8538.0 (M112) | 7.8538.0 (M112) 1x 7.8538.0 (M112) | 7.8538.0 (M112) 1x 7.8538.0 (M112) | 7.8538.0 (M112) 1x 7.8538.0 (M112) | |
| interference suppression filter Siemens | -R11 integrated --- | integrated --- | integrated --- | integrated --- | Ersatz durch: |
| frequency converter control unit instrument panel Siemens | -T1 7.8833.01120 6SL3210-1PE23-8AL0 7.7830.00710 6SL3244-0BB12-1BAx 7.7830.00100 6SL3255-0AA00-4CA1 | 7.8833.01130 6SL3210-1PE24-5AL0 7.7830.00710 6SL3244-0BB12-1BAx 7.7830.00100 6SL3255-0AA00-4CA1 | 7.8833.01140 6SL3210-1PE26-0AL0 7.7830.00710 6SL3244-0BB12-1BAx 7.7830.00100 6SL3255-0AA00-4CA1 | 7.8833.01140 6SL3210-1PE26-0AL0 7.7830.00710 6SL3244-0BB12-1BAx 7.7830.00100 6SL3255-0AA00-4CA1 | |
| motor cable - | -W211 4x6 AWG / 4G16 mm² 600 V - 80°C - EMV | 4x6 AWG / 4G16 mm² 600 V - 80°C - EMV | 4x 4 AWG / 25 mm² 600 V - 90°C | 4x 4 AWG / 25 mm² 600 V - 90°C | Ersatz durch: |
| connection - | -W280.1/2 -W281 -W282 8 AWG / 10 mm2 8 AWG / 10 mm2 8 AWG / 10 mm2 600 V - 90°C | 6 AWG / 16 mm2 6 AWG / 16 mm2 6 AWG / 16 mm2 600 V - 90°C | 4 AWG / 25 mm² 4 AWG / 25 mm² 4 AWG / 25 mm² 600 V - 90°C | 4 AWG / 25 mm² 4 AWG / 25 mm² 4 AWG / 25 mm² 600 V - 90°C | |
| supply terminals U1/V1/W1/GRD Handling Stripped length X connection supply | -X0: 894864.00010 Wieland 14-4 AWG/2,5-16 mm² fig. 2, Sht. 12 16 mm fig. 1, Sht. 13 | 894864.00010 Wieland 14-4 AWG/2,5-16 mm² fig. 2, Sht. 12 16 mm fig. 1, Sht. 13 | 3x 895314.0 3x 895314.00010 4x 895314.00040 Wago 8-1 AWG/10-50 mm² fig. 3, Sht. 12 30 mm fig. 2, Sht. 13 | 3x 895314.0 3x 895314.00010 4x 895314.00040 Wago 8-1 AWG/10-50 mm² fig. 3, Sht. 12 30 mm fig. 2, Sht. 13 | 05.02.2018 Datum M.Zeeh Bearbeiter M.Zeeh Geprüft M.Zeeh Norm Name Datum C-Änderung |

| model | performance-related components | | | | page 9 11 Bl. | | | | | | | | | | | | | | |
|---|---|---|---|---|--|-------|------------|---|------------|--------|---|---------|---------|------------|------|--|--|-------|--|
| | 50 hp EB+ FB-C (37 kW) | 50 hp FB-S (37 kW) | 60 hp EB+ FB-C (45 kW) | 60 hp FB-S (45 kW) | | | | | | | | | | | | | | | |
| machine power supply | 460 V ±10 %, 60 Hz | 460 V ±10 %, 60 Hz | 460 V ±10 %, 60 Hz | 460 V ±10 %, 60 Hz | = + UXB.XFC-U3020.04 | | | | | | | | | | | | | | |
| overload relay soundproofing casing Siemens | -B24 7.8741.00020 3RB3016-1NB0 0,32-1,25 A / S00 setting: 0,57 A NEC 430.32(C) incremental setting: 0,64 A | 7.8741.00020 3RB3016-1NB0 0,32-1,25 A / S00 setting: 0,57 A NEC 430.32(C) incremental setting: 0,64 A | 7.8741.00020 3RB3016-1NB0 0,32-1,25 A / S00 setting: 0,57 A NEC 430.32(C) incremental setting: 0,64 A | 7.8741.00020 3RB3016-1NB0 0,32-1,25 A / S00 setting: 0,57 A NEC 430.32(C) incremental setting: 0,64 A | | | | | | | | | | | | | | | |
| Surge protective device | -F86 Dehn 7.8669.00020 DG MU 3PY 480 3W+ G | 7.8669.00020 DG MU 3PY 480 3W+ G | 7.8669.00020 DG MU 3PY 480 3W+ G | 7.8669.00020 DG MU 3PY 480 3W+ G | electrical component parts list EB+FB performance-related components | | | | | | | | | | | | | | |
| Blower motor Siemens | -M1 894978.1 460 V-D/60 Hz 63,3 A, 3600U | 894978.1 460 V-D/60 Hz 63,3 A, 3600U | 894979.1 460 V-D/60 Hz 78 A, 3600U | 894979.1 460 V-D/60 Hz 78 A, 3600U | | | | | | | | | | | | | | | |
| vent motor soundproofing casing Sodeca/ebm | -M4 895040.00040 HC-31-2T / H-I-E 460 V-Y/60 Hz (3PH/GRD) 210W 0,62 A | 895426.0 W4D420 (ebm) 460 V-Y/60 Hz (3PH/GRD) 265W 0,62 A | 895040.00040 HC-31-2T / H-I-E 460 V-Y/60 Hz (3PH/GRD) 210W 0,62 A | 895426.0 W4D420 (ebm) 460 V-Y/60 Hz (3PH/GRD) 265W 0,62 A | | | | | | | | | | | | | | | |
| vent motor control cabinet Ruebsamen | -M8/-M9 7.2751.00360 LV600 (1Ph/N/GRD) 115 V/60 Hz, 80W 0,7 A | 7.2751.00360 LV600 (1Ph/N/GRD) 115 V/60 Hz, 80W 0,7 A | 7.2751.00360 LV600 (1Ph/N/GRD) 115 V/60 Hz, 80W 0,7 A | 7.2751.00360 LV600 (1Ph/N/GRD) 115 V/60 Hz, 80W 0,7 A | | | | | | | | | | | | | | | |
| line commutation reactor Siemens | -R1 integrated --- | integrated --- | integrated --- | integrated --- | | | | | | | | | | | | | | | |
| ferrit bead Magnetec | -R3.1 -R3.2 7.8538.0 (M112) 2x 7.8538.0 (M112) | 7.8538.0 (M112) 2x 7.8538.0 (M112) | 7.8538.0 (M112) 2x 7.8538.0 (M112) | 7.8538.0 (M112) 2x 7.8538.0 (M112) | | | | | | | | | | | | | | | |
| interference suppression filter Siemens | -R11 integrated --- | integrated --- | integrated --- | integrated --- | | | | | | | | | | | | | | | |
| frequency converter control unit instrument panel Siemens | -T1 7.8833.01150 6SL3210-1PE27-5AL0 7.7830.00710 6SL3244-0BB12-1BAx 7.7830.00100 6SL3255-0AA00-4CA1 | 7.8833.01150 6SL3210-1PE27-5AL0 7.7830.00710 6SL3244-0BB12-1BAx 7.7830.00100 6SL3255-0AA00-4CA1 | 7.8833.01160 6SL3210-1PE28-8AL0 7.7830.00710 6SL3244-0BB12-1BAx 7.7830.00100 6SL3255-0AA00-4CA1 | 7.8833.01160 6SL3210-1PE28-8AL0 7.7830.00710 6SL3244-0BB12-1BAx 7.7830.00100 6SL3255-0AA00-4CA1 | Kaeser KOMPRESSOREN Ursprung: Ersatz für: Ersatz durch: | | | | | | | | | | | | | | |
| motor cable | -W211 3x 2 AWG / 35 mm² 4 AWG / 25 mm² (GRD) 600 V - 90°C | 3x 2 AWG / 35 mm² 4 AWG / 25 mm² (GRD) 600 V - 90°C | 3x 1 AWG / 50 mm² 4 AWG / 25 mm² (GRD) 600 V - 90°C | 3x 1 AWG / 50 mm² 4 AWG / 25 mm² (GRD) 600 V - 90°C | | | | | | | | | | | | | | | |
| connection | -W280.1/2 -W281 -W282 2 AWG / 35 mm² 2 AWG / 35 mm² 2 AWG / 35 mm² 600 V - 90°C | 2 AWG / 35 mm² 2 AWG / 35 mm² 2 AWG / 35 mm² 600 V - 90°C | 2 AWG / 35 mm² 2 AWG / 35 mm² 2 AWG / 35 mm² 600 V - 90°C | 2 AWG / 35 mm² 2 AWG / 35 mm² 2 AWG / 35 mm² 600 V - 90°C | | | | | | | | | | | | | | | |
| supply terminals Handling Stripped length X connection supply | -X0: U1/V1/W1/GRD 3x 895314.0 3x 895314.00010 4x 895314.00040 Wago 8-1 AWG/10-50 mm² fig. 3, Sht. 12 30 mm fig. 2, Sht. 13 | 3x 895314.0 3x 895314.00010 4x 895314.00040 Wago 8-1 AWG/10-50 mm² fig. 3, Sht. 12 30 mm fig. 2, Sht. 13 | 3x 894385.0 3x 894385.00010 4x 894385.00040 Wago 4-4/0 AWG/25-95 mm² fig. 3, Sht. 12 36 mm fig. 2, Sht. 13 | 3x 894385.0 3x 894385.00010 4x 894385.00040 Wago 25-95 mm² Wago 4-4/0 AWG/25-95 mm² fig. 3, Sht. 12 36 mm fig. 2, Sht. 13 | | | | | | | | | | | | | | | |
| <table border="1"> <tr> <td>c</td> <td>Datum</td> <td>05.02.2018</td> </tr> <tr> <td>b</td> <td>Bearbeiter</td> <td>M.Zeeh</td> </tr> <tr> <td>a</td> <td>Geprüft</td> <td>IM.Zeeh</td> </tr> <tr> <td>C-Änderung</td> <td>Name</td> <td></td> </tr> <tr> <td></td> <td>Datum</td> <td></td> </tr> </table> | | | | | c | Datum | 05.02.2018 | b | Bearbeiter | M.Zeeh | a | Geprüft | IM.Zeeh | C-Änderung | Name | | | Datum | |
| c | Datum | 05.02.2018 | | | | | | | | | | | | | | | | | |
| b | Bearbeiter | M.Zeeh | | | | | | | | | | | | | | | | | |
| a | Geprüft | IM.Zeeh | | | | | | | | | | | | | | | | | |
| C-Änderung | Name | | | | | | | | | | | | | | | | | | |
| | Datum | | | | | | | | | | | | | | | | | | |

| model | performance-related components | | | | page 10 11 Bl. |
|---|--|---|---|---|---|
| | 75 hp EB+ FB (55 kW) | 75 hp FB-S (55 kW) | 100 hp EB+ FB-C (75 kW) | 100 hp FB-S (75 kW) | |
| machine power supply | 460 V ±10 %, 60 Hz | 460 V ±10 %, 60 Hz | 460 V ±10 %, 60 Hz | 460 V ±10 %, 60 Hz | = + UXB.XFC-U3020.04 |
| overload relay soundproofing casing | -B24 7.8741.00020 3RB3016-1NB0 0,32-1,25 A / S00 setting: 0,57 A NEC 430.32(C) incremental setting: 0,64 A Siemens | 7.8741.00020 3RB3016-1NB0 0,32-1,25 A / S00 setting: 0,57 A NEC 430.32(C) incremental setting: 0,64 A | 7.8741.00020 3RB3016-1NB0 0,32-1,25 A / S00 setting: 0,57 A NEC 430.32(C) incremental setting: 0,64 A | 7.8741.00020 3RB3016-1NB0 0,32-1,25 A / S00 setting: 0,57 A NEC 430.32(C) incremental setting: 0,64 A | |
| Surge protective device | -F86 Dehn 7.8669.00020 DG MU 3PY 480 3W+ G | 7.8669.00020 DG MU 3PY 480 3W+ G | 7.8669.00020 DG MU 3PY 480 3W+ G | 7.8669.00020 DG MU 3PY 480 3W+ G | electrical component parts list EB+FB performance-related components |
| Blower motor | -M1 894717.11000 460 V-D/60 Hz 92 A, 3600U Siemens | 894717.11000 460 V-D/60 Hz 92 A, 3600U | 894719.11000 460 V-D/60 Hz 125 A, 3600U | 894719.11000 460 V-D/60 Hz 125 A, 3600U | |
| vent motor soundproofing casing | -M4 895040.00040 HC-31-2T / H-I-E 460 V-Y/60 Hz (3PH/GRD) 210W 0,62 A Sodeca/ebm | 895426.0 W4D420 (ebm) 460 V-Y/60 Hz (3PH/GRD) 265W 0,62 A | 895040.00040 HC-31-2T / H-I-E 460 V-Y/60 Hz (3PH/GRD) 210W 0,62 A | 895426.0 W4D420 (ebm) 460 V-Y/60 Hz (3PH/GRD) 265W 0,62 A | KAESER KOMPRESSOREN Ursprung |
| vent motor control cabinet | -M8/-M9 7.2751.00360 LV600 (1PhN/GRD) 115 V/60 Hz, 80W 0,7 A Ruebsamen | 7.2751.00360 LV600 (1PhN/GRD) 115 V/60 Hz, 80W 0,7 A | 7.2751.00360 LV600 (1PhN/GRD) 115 V/60 Hz, 80W 0,7 A | 7.2751.00360 LV600 (1PhN/GRD) 115 V/60 Hz, 80W 0,7 A | |
| line commutation reactor | -R1 Siemens integrated --- | integrated --- | integrated --- | integrated --- | Ersatz für: |
| ferrit bead | -R3.1 -R3.2 Magnetec 7.8538.00020 (M113) 2x 7.8538.00020 (M113) | 7.8538.00020 (M113) 2x 7.8538.00020 (M113) | 7.8538.00020 (M113) 1x 7.8538.00020 (M113) | 7.8538.00020 (M113) 1x 7.8538.00020 (M113) | |
| interference suppression filter | -R11 Siemens integrated --- | integrated --- | integrated --- | integrated --- | Ersatz durch: |
| frequency converter control unit instrument panel | -T1 7.8833.01170 6SL3210-1PE31-1AL0 7.7830.00710 6SL3244-0BB12-1BAx 7.7830.00100 Siemens 6SL3255-0AA00-4CA1 | 7.8833.01170 6SL3210-1PE31-1AL0 7.7830.00710 6SL3244-0BB12-1BAx 7.7830.00100 6SL3255-0AA00-4CA1 | 7.8833.01180 6SL3210-1PE31-5AL0 7.7830.00710 6SL3244-0BB12-1BAx 7.7830.00100 6SL3255-0AA00-4CA1 | 7.8833.01180 6SL3210-1PE31-5AL0 7.7830.00710 6SL3244-0BB12-1BAx 7.7830.00100 6SL3255-0AA00-4CA1 | |
| motor cable | -W211 3x 2/0 AWG / 70 mm ² 2 AWG / 35 mm ² (GRD) 600 V - 90°C | 3x 2/0 AWG / 70 mm ² 2 AWG / 35 mm ² (GRD) 600 V - 90°C | 3x 3/0 AWG / 95 mm ² 1 AWG / 50 mm ² (GRD) 600 V - 90°C | 3x 3/0 AWG / 95 mm ² 1 AWG / 50 mm ² (GRD) 600 V - 90°C | Ersatz durch: |
| connection | -W280.1/2 -W281 -W282 1 AWG / 50 mm ² 1 AWG / 50 mm ² 1 AWG / 50 mm ² 600 V - 90°C | 1 AWG / 50 mm ² 1 AWG / 50 mm ² 1 AWG / 50 mm ² 600 V - 90°C | 2/0 AWG / 70 mm ² 2/0 AWG / 70 mm ² 2/0 AWG / 70 mm ² 600 V - 90°C | 2/0 AWG / 70 mm ² 2/0 AWG / 70 mm ² 2/0 AWG / 70 mm ² 600 V - 90°C | |
| supply terminals | -X0: U1/V1/W1/GRD 3x 894385.0 3x 894385.00010 4x 894385.00040 Wago 4-4/0 AWG/25-95 mm ² fig. 3, Sht. 12 36 mm Stripped length X connection fig. 2, Sht. 13 | 3x 894385.0 3x 894385.00010 4x 894385.00040 Wago 4-4/0 AWG/25-95 mm ² fig. 3, Sht. 12 36 mm fig. 2, Sht. 13 | 3x 894385.0 3x 894385.00010 4x 894385.00040 Wago 4-4/0 AWG/25-95 mm ² fig. 3, Sht. 12 36 mm fig. 2, Sht. 13 | 3x 894385.0 3x 894385.00010 4x 894385.00040 Wago 4-4/0 AWG/25-95 mm ² fig. 3, Sht. 12 36 mm fig. 2, Sht. 13 | Datum 05.02.2018 Bearbeiter M.Zeeh Geprüft M.Zeeh Norm Name Datum |
| supply | | | | | |

| model | performance-related components | | | | | page 11 | | | | | | | | | | | | | | | | | | | | | | | | | | | | | | | | | | | |
|---|---|--|---|---|---|---|-------|------------|------------|--------|---------|---------|------|--|---|--|--|--|--|--|--|--|--|---|--|--|--|--|--|--|--|--|------------|--|-------|------|--|--|--|--|--|
| | 125 hp FB-C (90 kW) | 125 hp FB-S (90 kW) | 150 hp FB-C (110 kW) | 150 hp FB-S (110 kW) | 175 hp FB (132 kW) | | | | | | | | | | | | | | | | | | | | | | | | | | | | | | | | | | | | |
| machine power supply | 460 V ±10 %, 60 Hz | 460 V ±10 %, 60 Hz | 460 V ±10 %, 60 Hz | 460 V ±10 %, 60 Hz | 460 V ±10 %, 60 Hz | = + UXB.XFC-U3020.04 | | | | | | | | | | | | | | | | | | | | | | | | | | | | | | | | | | | |
| overload relay soundproofing casing | -B24 7.8741.00020 3RB3016-1NB0 0,32-1,25 A / S00 setting: 0,57 A NEC 430.32(C) incremental setting: 0,64 A Siemens | 7.8741.00020 3RB3016-1NB0 0,32-1,25 A / S00 setting: 0,57 A NEC 430.32(C) incremental setting: 0,64 A | 7.8741.00020 3RB3016-1NB0 0,32-1,25 A / S00 setting: 0,57 A NEC 430.32(C) incremental setting: 0,64 A | 7.8741.00020 3RB3016-1NB0 0,32-1,25 A / S00 setting: 0,57 A NEC 430.32(C) incremental setting: 0,64 A | 7.8741.00020 3RB3016-1NB0 0,32-1,25 A / S00 setting: 0,57 A NEC 430.32(C) incremental setting: 0,64 A | | | | | | | | | | | | | | | | | | | | | | | | | | | | | | | | | | | | |
| Surge protective device | -F86 Dehn 7.8669.00020 DG MU 3PY 480 3W+ G | 7.8669.00020 DG MU 3PY 480 3W+ G | 7.8669.00020 DG MU 3PY 480 3W+ G | 7.8669.00020 DG MU 3PY 480 3W+ G | 7.8669.00020 DG MU 3PY 480 3W+ G | electrical component parts list FB performance-related components | | | | | | | | | | | | | | | | | | | | | | | | | | | | | | | | | | | |
| Blower motor | -M1 Siemens 894723.11000 460 V-D/60 Hz 158 A, 1800U | 894722.11000 460 V-D/60 Hz 149 A, 3600U | 895025.11000 460 V-D/60 Hz 191 A, 1800U | 894724.11000 460 V-D/60 Hz 185 A, 3600U | 894726.11000 460 V-D/60 Hz 225 A, 1800U | | | | | | | | | | | | | | | | | | | | | | | | | | | | | | | | | | | | |
| vent motor soundproofing casing | -M4 Sodeca/ebm 895040.00040 HC-31-2T / H-I-E 460 V-Y/60 Hz (3PH/GRD) 210W 0,62 A | 895426.0 W4D420 (ebm) 460 V-Y/60 Hz (3PH/GRD) 265W 0,62 A | 895040.00040 HC-31-2T / H-I-E 460 V-Y/60 Hz (3PH/GRD) 210W 0,62 A | 895426.0 W4D420 (ebm) 460 V-Y/60 Hz (3PH/GRD) 265W 0,62 A | 895040.00040 HC-31-2T / H-I-E 460 V-Y/60 Hz (3PH/GRD) 210W 0,62 A | | | | | | | | | | | | | | | | | | | | | | | | | | | | | | | | | | | | |
| vent motor control cabinet | -M8/-M9 Ruebsamen 7.2751.00360 LV600 (1Ph/N/GRD) 115 V/60 Hz, 80W 0,7 A | 7.2751.00360 LV600 (1Ph/N/GRD) 115 V/60 Hz, 80W 0,7 A | 7.2751.00360 LV600 (1Ph/N/GRD) 115 V/60 Hz, 80W 0,7 A | 7.2751.00360 LV600 (1Ph/N/GRD) 115 V/60 Hz, 80W 0,7 A | 7.2751.00360 LV600 (1Ph/N/GRD) 115 V/60 Hz, 80W 0,7 A | | | | | | | | | | | | | | | | | | | | | | | | | | | | | | | | | | | | |
| line commutation reactor | -R1 Siemens integrated --- | integrated --- | integrated --- | integrated --- | integrated --- | | | | | | | | | | | | | | | | | | | | | | | | | | | | | | | | | | | | |
| ferrit bead | -R3.1 -R3.2 Magnetec 7.8538.00020 (M113) 1x 7.8538.00020 (M113) | 7.8538.00020 (M113) 1x 7.8538.00020 (M113) | 7.8538.00020 (M113) 1x 7.8538.00020 (M113) | 7.8538.00020 (M113) 1x 7.8538.00020 (M113) | 7.8538.00020 (M113) 1x 7.8538.00020 (M113) | | | | | | | | | | | | | | | | | | | | | | | | | | | | | | | | | | | | |
| interference suppression filter | -R11 Siemens integrated --- | integrated --- | integrated --- | integrated --- | integrated --- | | | | | | | | | | | | | | | | | | | | | | | | | | | | | | | | | | | | |
| frequency converter control unit instrument panel | -T1 Siemens 7.8833.01190 6SL3210-1PE31-8AL0 7.7830.00710 6SL3244-0BB12-1BAx 7.7830.00100 6SL3255-0AA00-4CA1 | 7.8833.01190 6SL3210-1PE31-8AL0 7.7830.00710 6SL3244-0BB12-1BAx 7.7830.00100 6SL3255-0AA00-4CA1 | 7.8833.01200 6SL3210-1PE32-1AL0 7.7830.00710 6SL3244-0BB12-1BAx 7.7830.00100 6SL3255-0AA00-4CA1 | 7.8833.01200 6SL3210-1PE32-1AL0 7.7830.00710 6SL3244-0BB12-1BAx 7.7830.00100 6SL3255-0AA00-4CA1 | 7.8833.01210 6SL3210-1PE32-5AL0 7.7830.00710 6SL3244-0BB12-1BAx 7.7830.00100 6SL3255-0AA00-4CA1 | | | | | | | | | | | | | | | | | | | | | | | | | | | | | | | | | | | | |
| motor cable | -W211 3x 4/0 AWG / 120 mm ² 2/0 AWG / 70 mm ² (GRD) 600 V - 90°C | 3x 4/0 AWG / 120 mm ² 2/0 AWG / 70 mm ² (GRD) 600 V - 90°C | 3x 4/0 AWG / 120 mm ² 2/0 AWG / 70 mm ² (GRD) 600 V - 90°C | 3x 4/0 AWG / 120 mm ² 2/0 AWG / 70 mm ² (GRD) 600 V - 90°C | 3x 4/0 AWG / 120 mm ² 2/0 AWG / 70 mm ² (GRD) 600 V - 90°C | | | | | | | | | | | | | | | | | | | | | | | | | | | | | | | | | | | | |
| connection | -W280.1/2 -W281 -W282 3/0 AWG / 95 mm ² 3/0 AWG / 95 mm ² 3/0 AWG / 95 mm ² 600 V - 90°C | 3/0 AWG / 95 mm ² 3/0 AWG / 95 mm ² 3/0 AWG / 95 mm ² 600 V - 90°C | 4/0 AWG / 120 mm ² 4/0 AWG / 120 mm ² 4/0 AWG / 120 mm ² 600 V - 90°C | 4/0 AWG / 120 mm ² 4/0 AWG / 120 mm ² 4/0 AWG / 120 mm ² 600 V - 90°C | 2x 2/0 AWG / 70 mm ² 4/0 AWG / 120 mm ² 4/0 AWG / 120 mm ² 600 V - 90°C | | | | | | | | | | | | | | | | | | | | | | | | | | | | | | | | | | | | |
| supply terminals | -X0: U1/N1/W1 Handling Stripped length X 6x 894385.0 3x 894385.00030 3x 894385.00040 Wago 4-4/0AWG / 25-95mm ² fig. 3, Sht. 13 36 mm | 6x 894385.0 3x 894385.00030 3x 894385.00040 Wago 4-4/0AWG / 25-95mm ² fig. 3, Sht. 13 36 mm | 6x 895545.0 3x 895545.00030 3x 895545.00040 Wago (50-185mm ²) 1 AWG - 350 MCM fig. 3, Sht. 13 45 mm | 6x 895545.0 3x 895545.00030 3x 895545.00040 Wago (50-185mm ²) 1 AWG - 350 MCM fig. 3, Sht. 13 45 mm | 6x 895545.0 3x 895545.00030 3x 895545.00040 Wago (50-185mm ²) 1 AWG - 350 MCM fig. 3, Sht. 13 45 mm | | | | | | | | | | | | | | | | | | | | | | | | | | | | | | | | | | | | |
| PE-rail | -X0:PE Torque Stripped length X 832489.00010 15Nm 25 mm+ Conductor crimp pins | 832489.00010 15Nm 25 mm+ Conductor crimp pins | 832489.00010 15Nm 25 mm+ Conductor crimp pins | 832489.00010 15Nm 25 mm+ Conductor crimp pins | 832489.00010 15Nm 25 mm+ Conductor crimp pins | | | | | | | | | | | | | | | | | | | | | | | | | | | | | | | | | | | | |
| supply | -connection fig. 3, Sht. 15 | fig. 3, Sht. 15 | fig. 3, Sht. 15 | fig. 3, Sht. 15 | fig. 3, Sht. 15 | | | | | | | | | | | | | | | | | | | | | | | | | | | | | | | | | | | | |
| <table border="1" style="width:100%; border-collapse: collapse;"> <tr> <td style="width:5%;">c</td> <td style="width:15%;">Datum</td> <td style="width:15%;">05.02.2018</td> <td style="width:15%;">Bearbeiter</td> <td style="width:15%;">M.Zeeh</td> <td style="width:15%;">Geprüft</td> <td style="width:15%;">IM/Zeeh</td> <td style="width:15%;">Norm</td> <td style="width:15%;"></td> </tr> <tr> <td>a</td> <td></td> <td></td> <td></td> <td></td> <td></td> <td></td> <td></td> <td></td> </tr> <tr> <td>b</td> <td></td> <td></td> <td></td> <td></td> <td></td> <td></td> <td></td> <td></td> </tr> <tr> <td colspan="2">C-Änderung</td> <td>Datum</td> <td>Name</td> <td colspan="5"></td> </tr> </table> | | | | | | c | Datum | 05.02.2018 | Bearbeiter | M.Zeeh | Geprüft | IM/Zeeh | Norm | | a | | | | | | | | | b | | | | | | | | | C-Änderung | | Datum | Name | | | | | |
| c | Datum | 05.02.2018 | Bearbeiter | M.Zeeh | Geprüft | IM/Zeeh | Norm | | | | | | | | | | | | | | | | | | | | | | | | | | | | | | | | | | |
| a | | | | | | | | | | | | | | | | | | | | | | | | | | | | | | | | | | | | | | | | | |
| b | | | | | | | | | | | | | | | | | | | | | | | | | | | | | | | | | | | | | | | | | |
| C-Änderung | | Datum | Name | | | | | | | | | | | | | | | | | | | | | | | | | | | | | | | | | | | | | | |

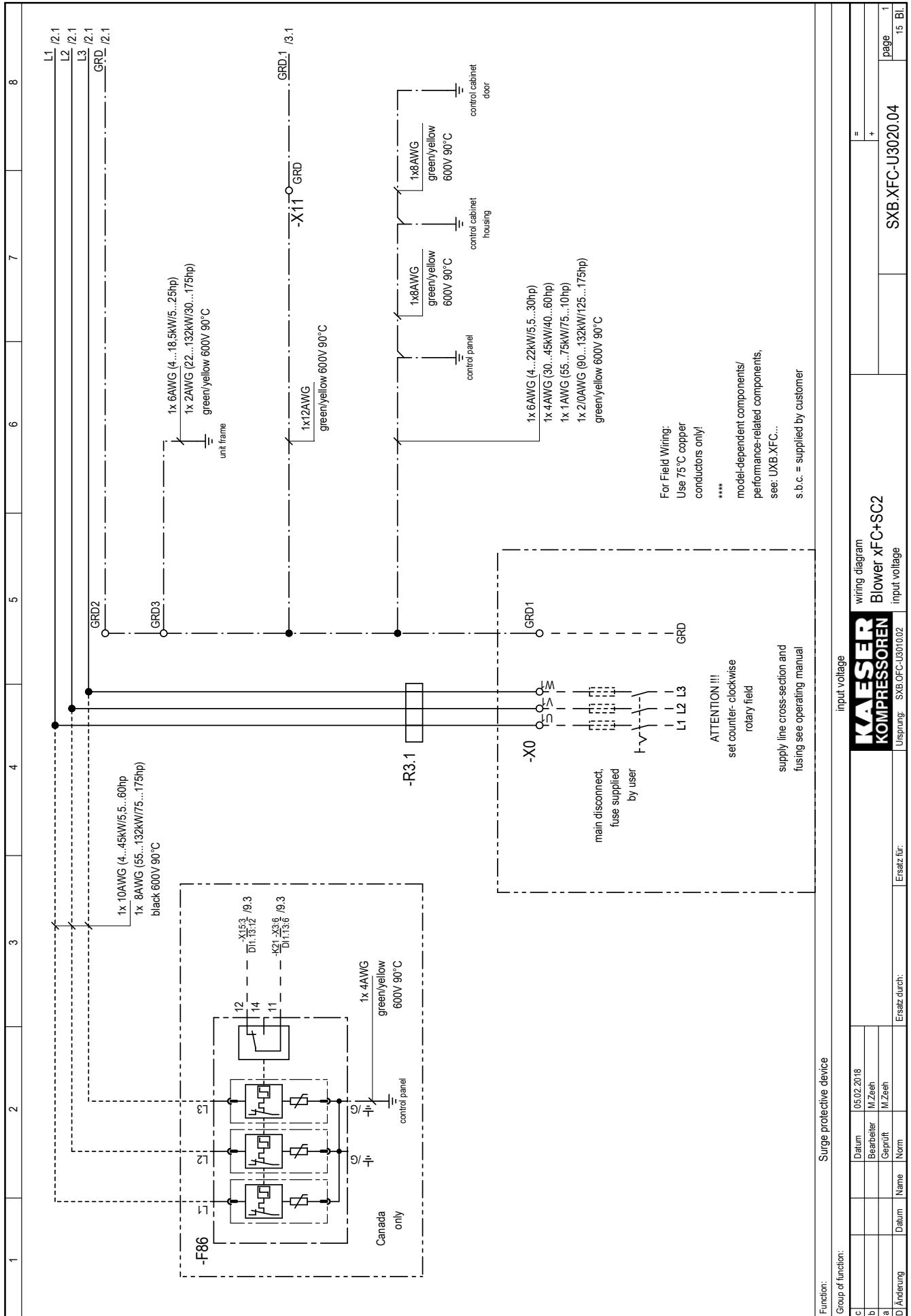

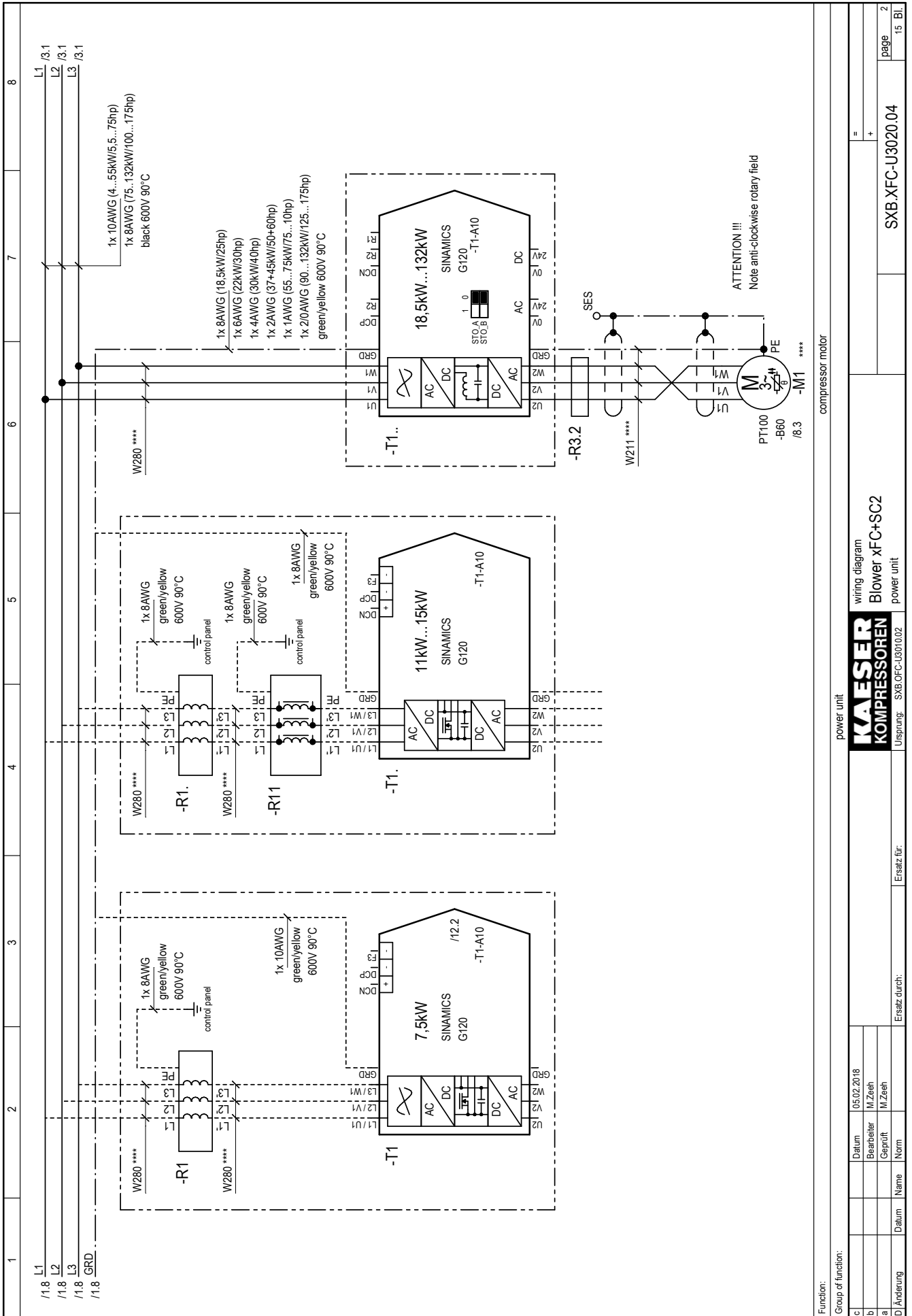

| | | | |
|--------------------|------------|----------------|-----------------------------|
| Function: | | power unit | |
| Group of function: | | wiring diagram | |
| c | Datum | 05.02.2018 | = |
| b | Bearbeiter | M.Zeeh | + |
| a | Geprüft | M.Zeeh | |
| D | Änderung | Datum | Name |
| | | | Ersatz durch: |
| | | | Ursprung: SXB.DFC-LB3010.02 |
| | | | power unit |
| | | | SXB.XFC-U3020.04 |
| | | | page 2 |
| | | | 15 Bl. |

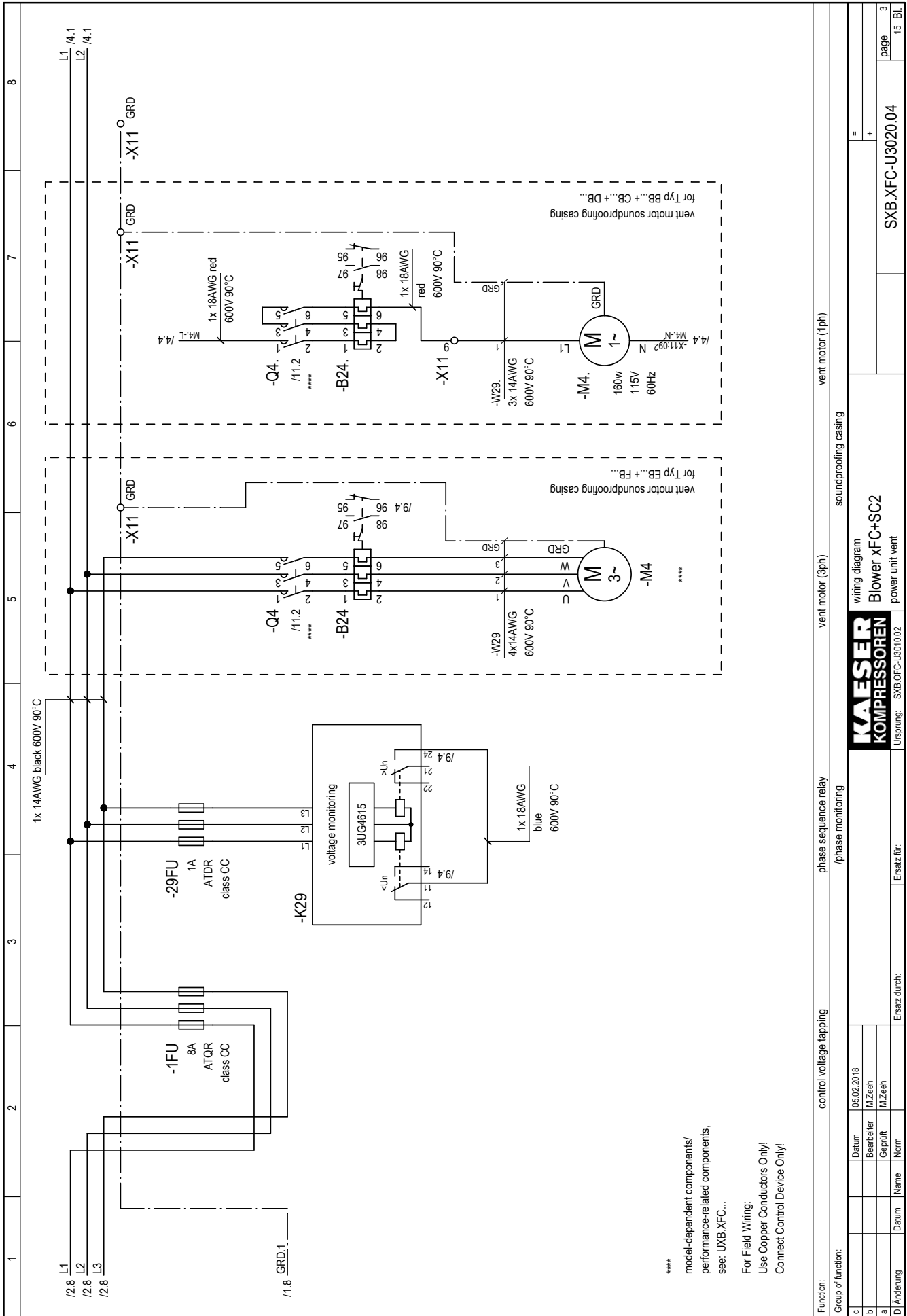

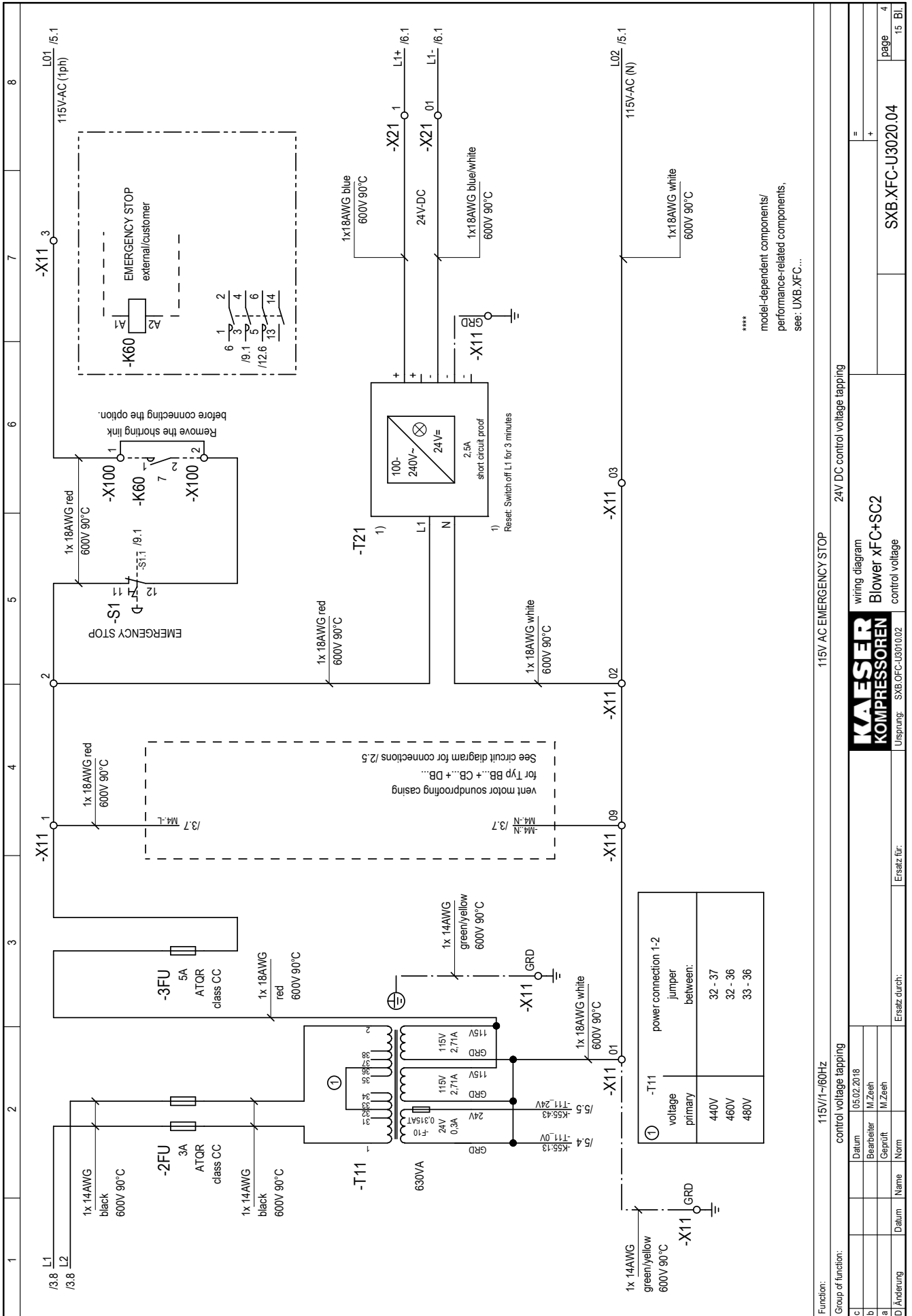

| | | | |
|--------------------|------------|-----------------------------|---------------|
| Function: | | 115V/1~60Hz | |
| Group of function: | | control voltage tapping | |
| c | Datum | 05.02.2018 | |
| b | Bearbeiter | M.Zeeh | |
| a | Geprüft | M.Zeeh | |
| D | Änderung | Datum | Name |
| | | | Ersatz durch: |
| | | Ersatz für: | |
| | | Ursprung: SXB.DFC-LB3010.02 | |
| | | wiring diagram | |
| | | Blower xFC+SC2 | |
| | | control voltage | |
| | | SXB.XFC-U3020.04 | |
| | | page | 4 |
| | | 15 Bl. | |

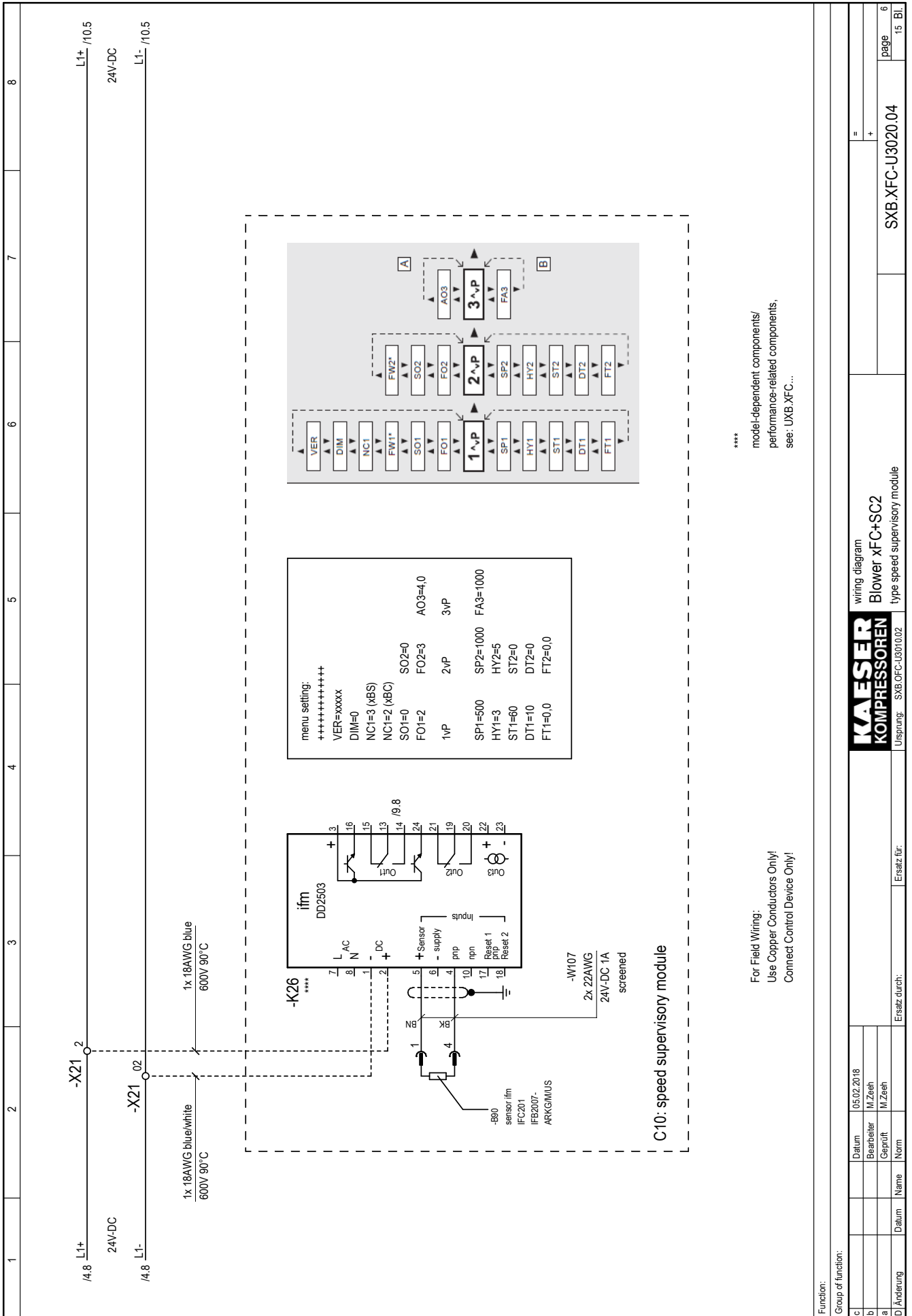

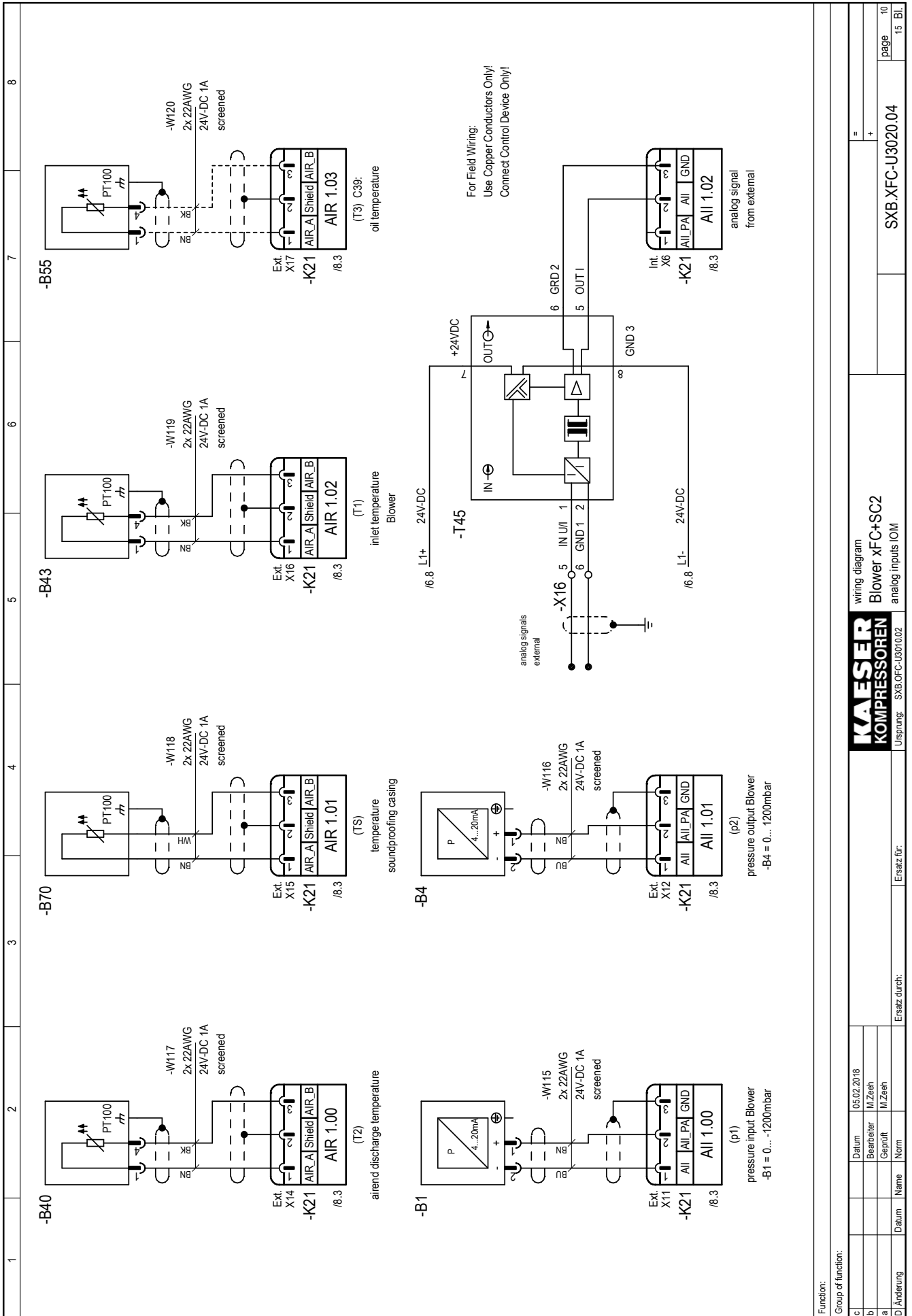

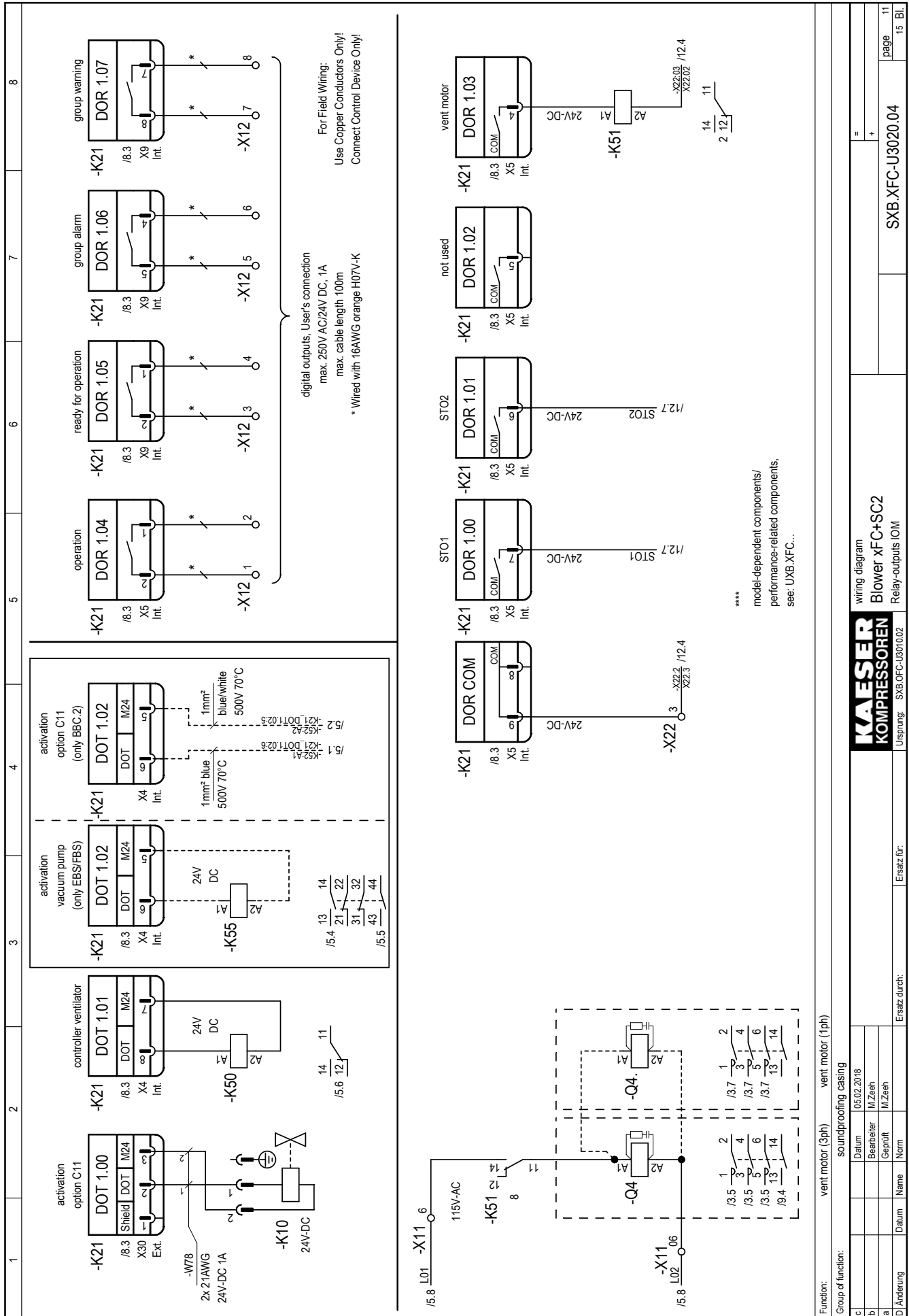

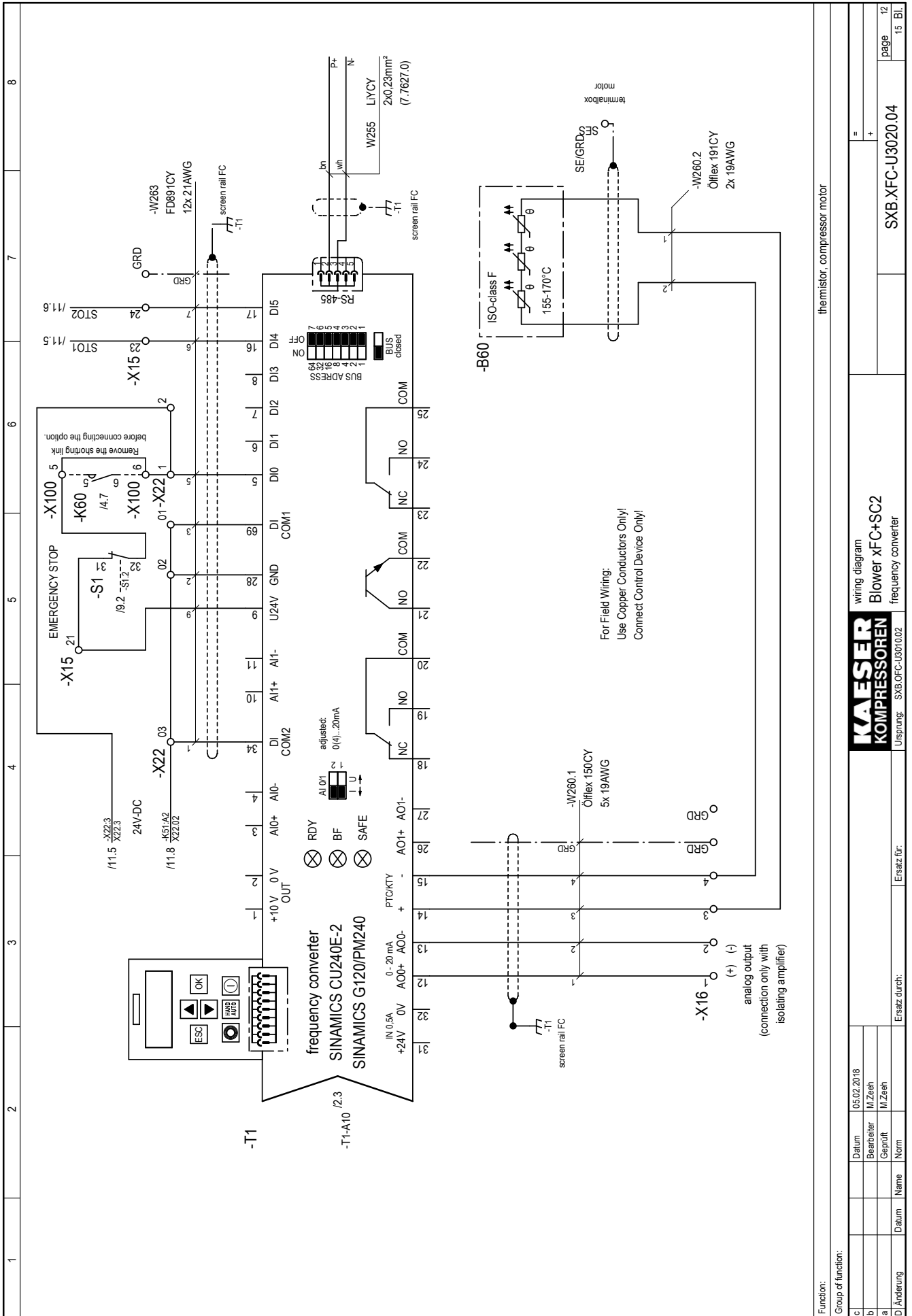

Function:
thermistor, compressor motor

KAESER
KOMPRESSOREN

wiring diagram
Blower xFC+SC2
frequency converter

Ursprung: SXB.DFC-LB3010.02

SXB.XFC-U3020.04

page 12
15 Bl.

1 2 3 4 5 6 7 8

fig.: 1 Handling control line terminal

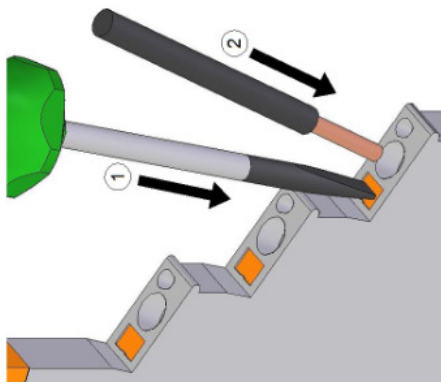

fig.: 2 Handling supply terminals

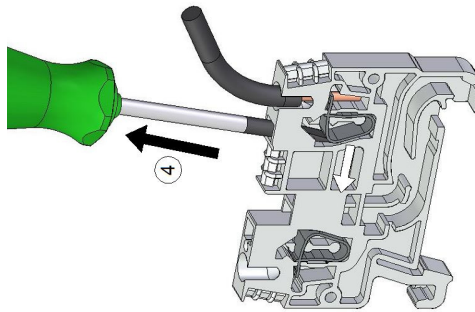
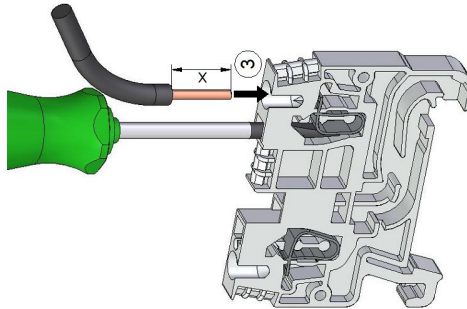
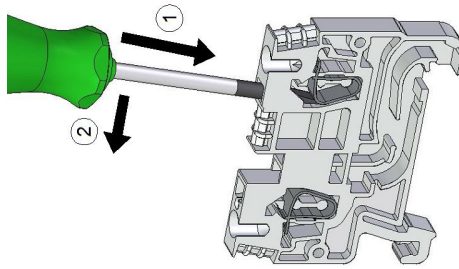
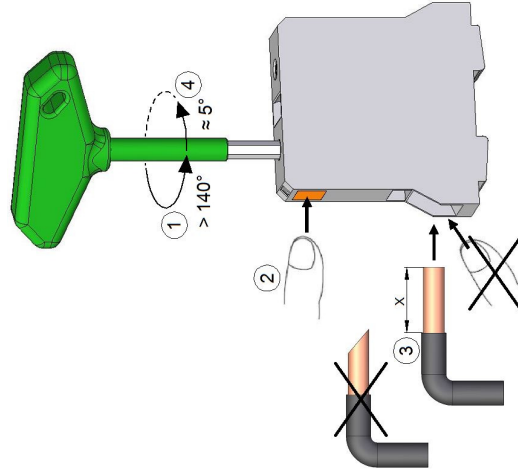

fig.: 3 Handling supply terminals



Function:

Group of function:

| | | |
|---|------------|-----------------|
| c | Datum | 05.02.2018 |
| b | Bearbeiter | M.Zeesh |
| a | Geprüft | M.Zeesh |
| d | Änderung | Datum Name Norm |

Ersatz durch:

Ersatz für:

KAESER
KOMPRESSOREN
Ursprung: SXB.DFC-LB3010.02

wiring diagram
Blower xFC+SC2
Handling terminals

SXB.XFC-U3020.04

page 13
15 Bl.

1 2 3 4 5 6 7 8

fig.: 1 Feed line connection

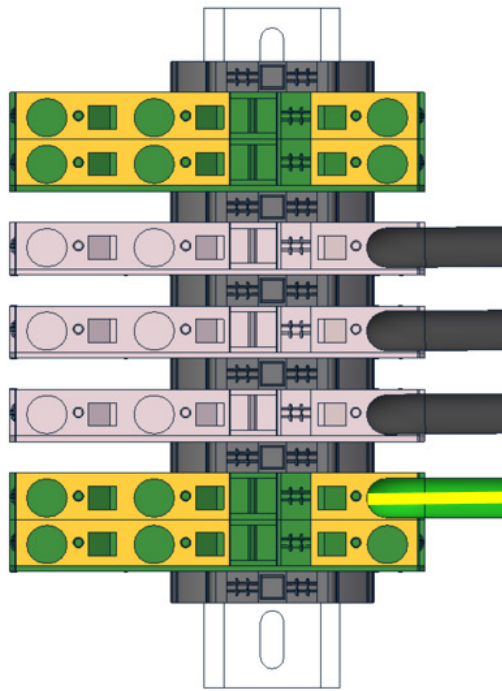
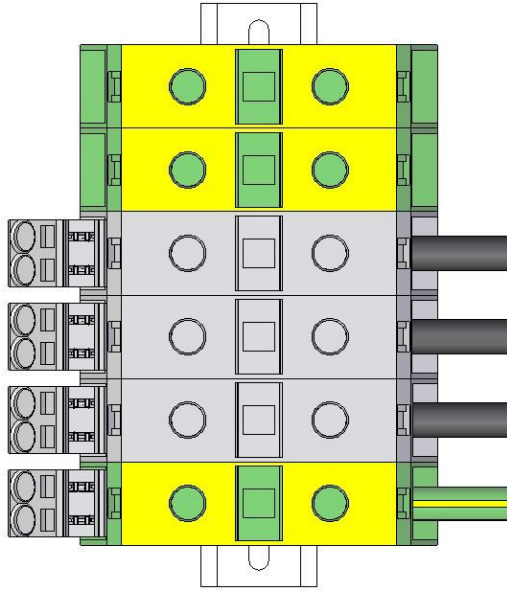

fig.: 2 Feed line connection



Function:

Group of function:

| | | |
|---|------------|------------|
| c | Datum | 05.02.2018 |
| b | Bearbeiter | M.Zeesh |
| a | Geprüft | M.Zeesh |
| D | Änderung | Datum Name |

Ersatz durch:

Ersatz für:

KAESER
KOMPRESSOREN
Ursprung: SXB.DFC-L8010.02

wiring diagram
Blower xFC+SC2
Feed line connection

SXB.XFC-U3020.04

page 14
15 Bl.

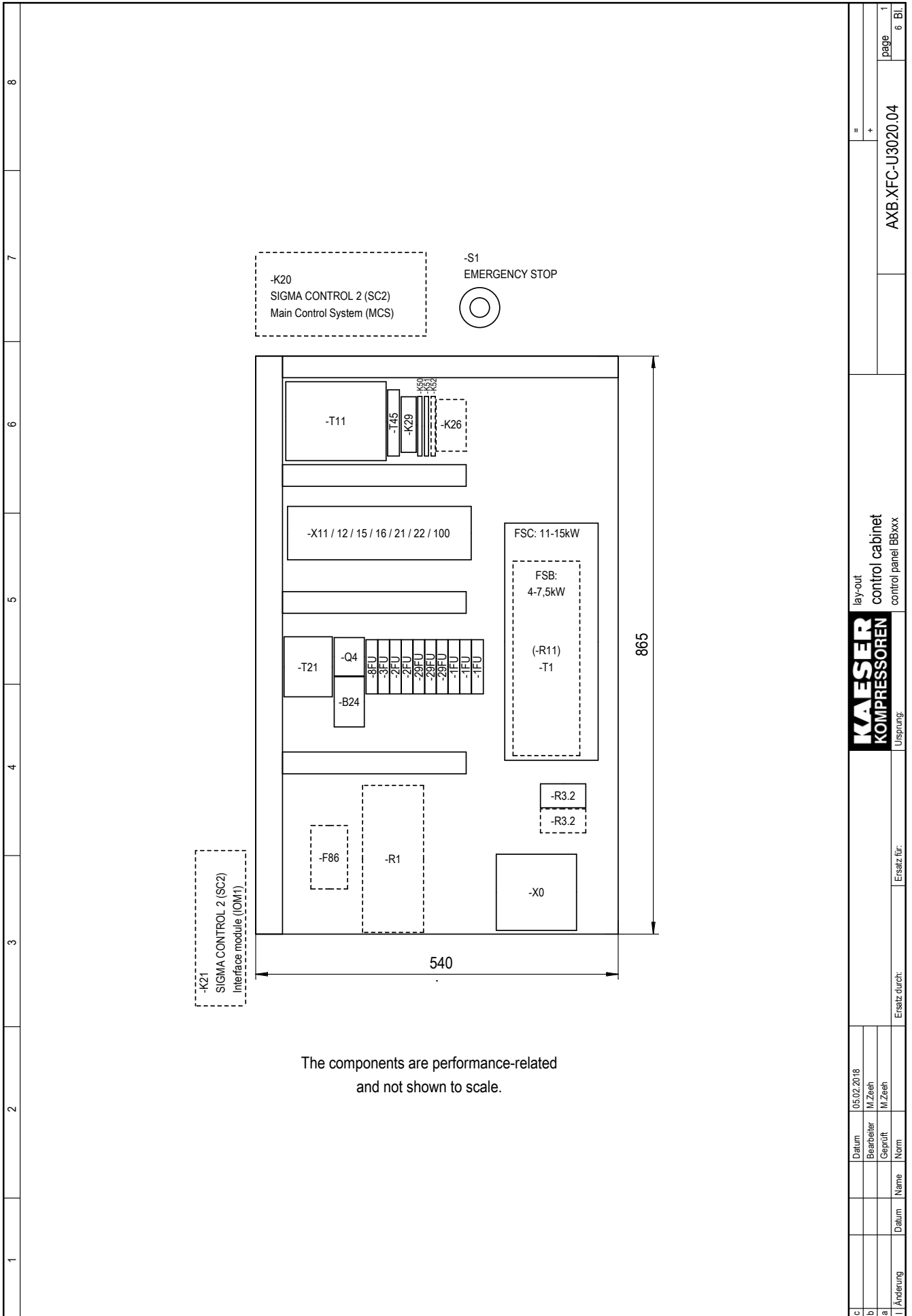

| | | | | | | | |
|---|--|------------|--|--------------------------------------|--|---------------|-------|
| = | | + | | AXB.XFC-U3020.04 | | page 1 | 6 Bl. |
| lay-out control cabinet control panel BBxxx | | | | KAESER KOMPRESSOREN Ursprung: | | | |
| Datum | | 05.02.2018 | | Ersatz durch: | | Ersatz durch: | |
| Bearbeiter | | M.Zeeh | | Name | | Name | |
| Geprüft | | M.Zeeh | | Datum | | Datum | |
| Norm | | Norm | | I Änderung | | I Änderung | |

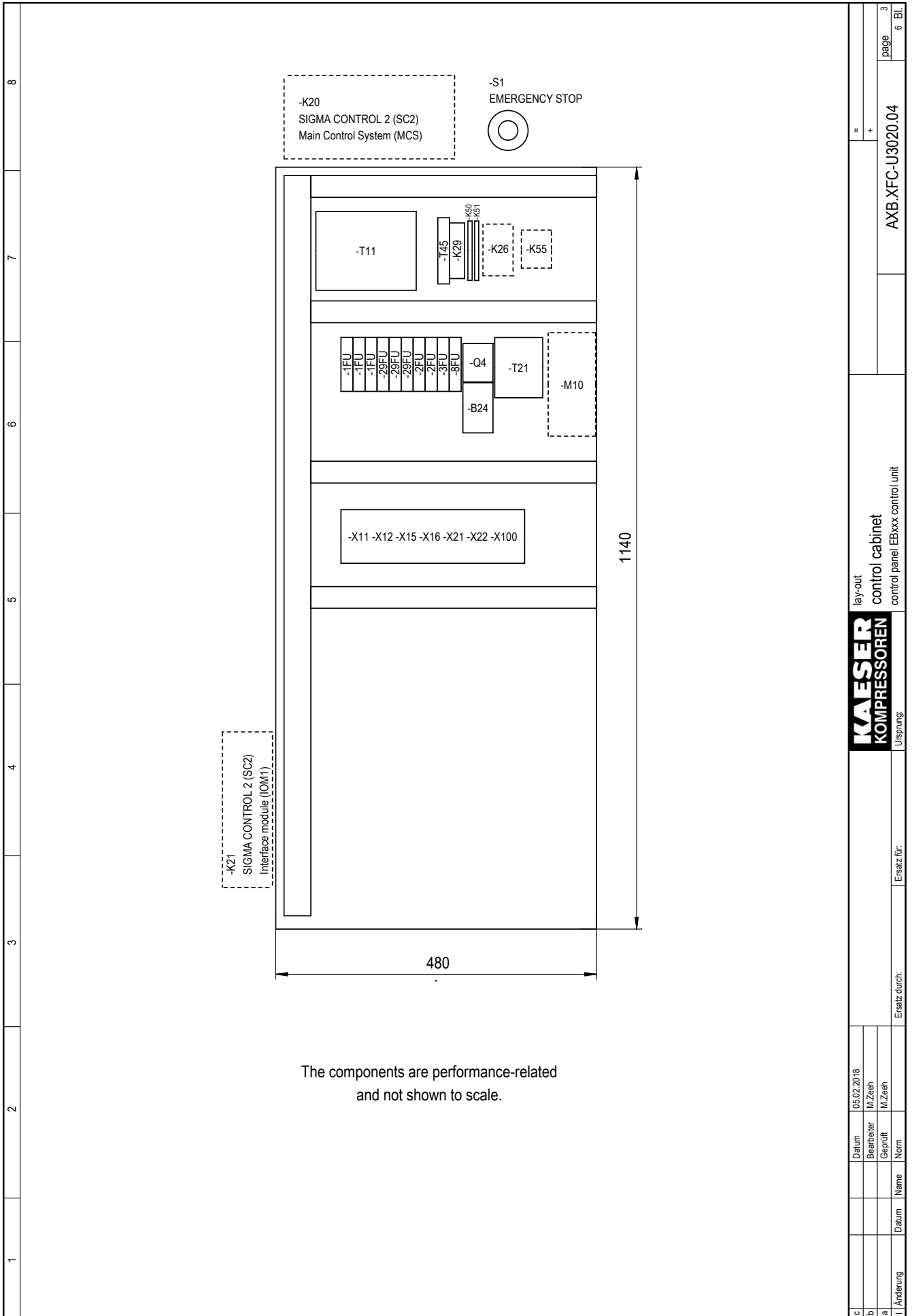

| | | | | | | | |
|----------------------------------|--|------------|--|------------------|--|-------|---|
| = | | + | | AXB.XFC-U3020.04 | | page | 3 |
| | | | | | | 6 Bl. | |
| lay-out | | | | control cabinet | | | |
| control panel EBxxx control unit | | | | | | | |
| KAESER KOMPRESSOREN | | | | Ursprung: | | | |
| Datum | | 05.02.2018 | | Ersatz durch: | | | |
| Bearbeiter | | M.Zeeh | | Ersatz durch: | | | |
| Geprüft | | M.Zeeh | | Ersatz durch: | | | |
| Norm | | | | Ersatz durch: | | | |
| Name | | | | Ersatz durch: | | | |
| Datum | | | | Ersatz durch: | | | |
| I Änderung | | | | Ersatz durch: | | | |

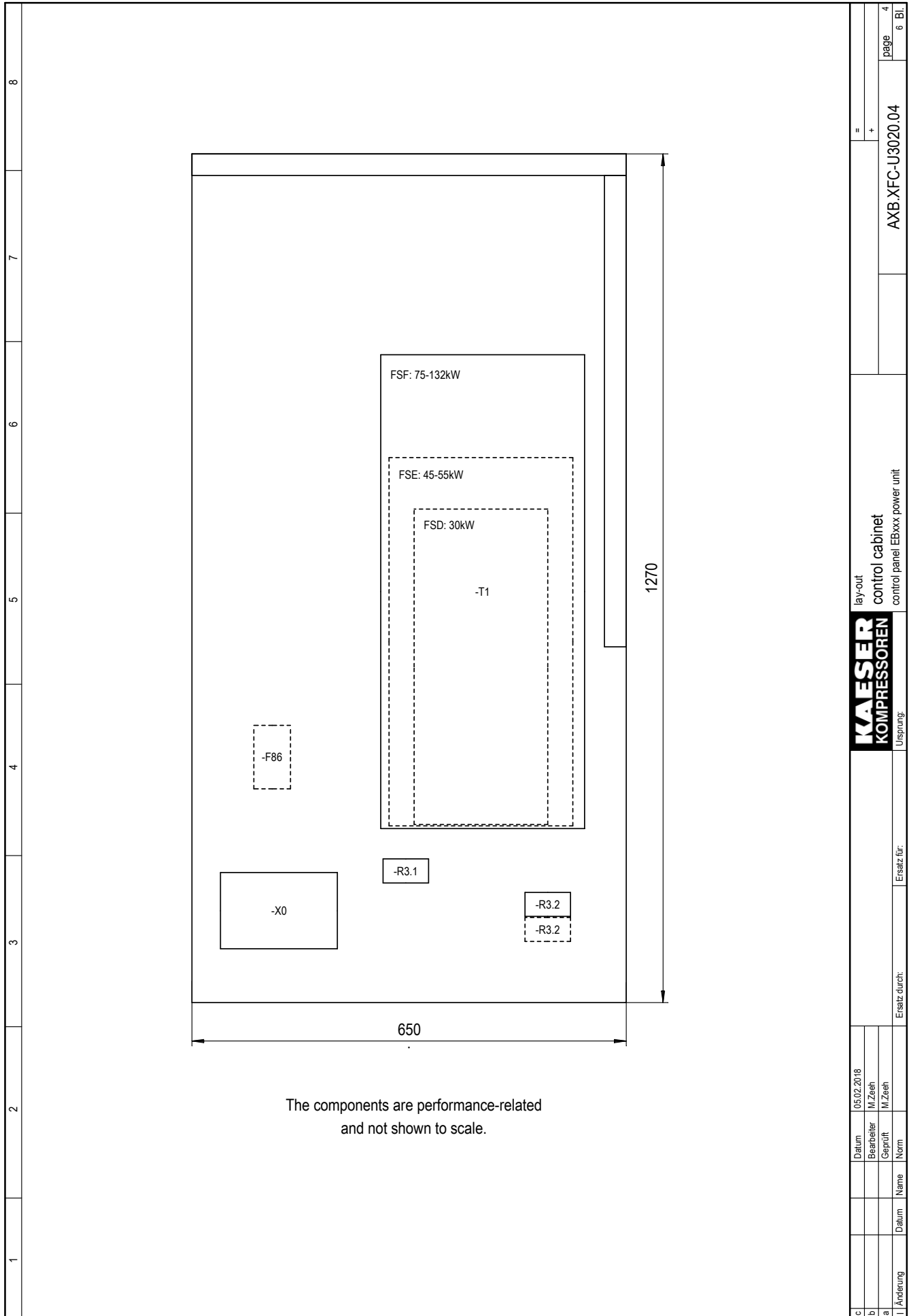

| | | | | | | | | |
|---|------------|------------|---------------|-------------|--|-----|------------------|-----------|
| c | Datum | 05.02.2018 | Ersatz durch: | Ersatz für: | lay-out control cabinet control panel EBxxx power unit | = + | AXB.XFC-U3020.04 | page 4 |
| | Bearbeiter | M.Zeeh | | | | | | |
| b | Geprüft | | | | | | | |
| a | Norm | | | | | | | |
| I | Änderung | Datum | Name | | | | | |

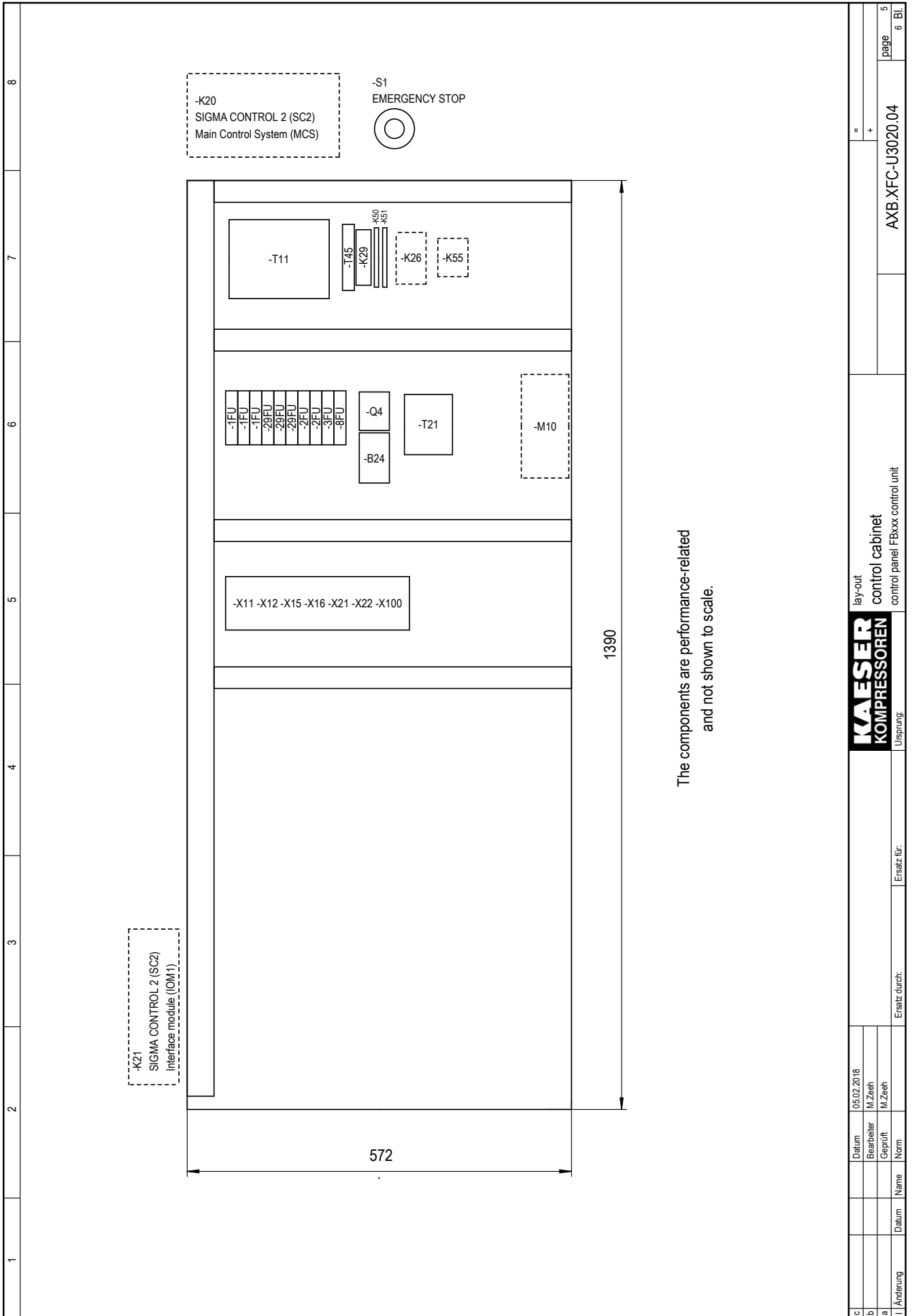

| | | | | | | | |
|-------------------------------|------------|---------------|--|----------------------------------|--|-------|---|
| = | | + | | AXB.XFC-U3020.04 | | page | 5 |
| | | | | | | 6 Bl. | |
| lay-out control cabinet | | | | control panel FBxxx control unit | | | |
| KAESER KOMPRESSOREN | | | | Ursprung: | | | |
| Datum | 05.02.2018 | Ersatz durch: | | Datum | | | |
| Bearbeiter | M.Zeeh | | | Name | | | |
| Geprüft | IM.Zeeh | | | Datum | | | |
| Norm | | | | | | | |
| I Änderung | | | | | | | |

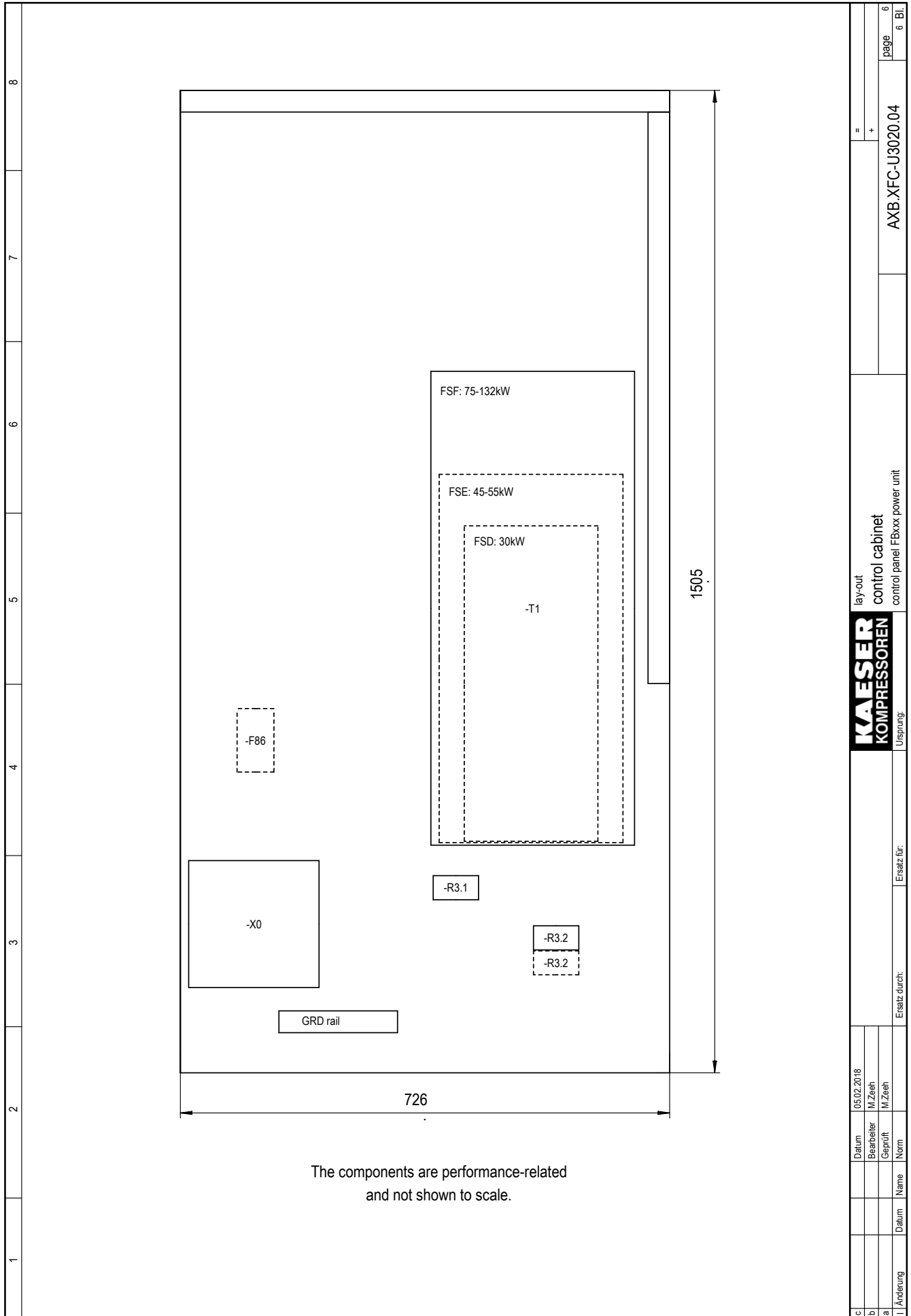

| | | | | | | | | | | | | |
|---|------------|------------|---------------|-------------|---------|-----------------|--------------------------------|---|---|------------------|-------|---|
| c | Datum | 05.02.2018 | Ersatz durch: | Ersatz für: | lay-out | control cabinet | control panel FBxxx power unit | = | + | AXB.XFC-U3020.04 | page | 6 |
| | Bearbeiter | M.Zeeh | | | | | | | | | 6 Bl. | |
| b | Geprüft | | | | | | | | | | | |
| a | Norm | | | | | | | | | | | |
| I | Änderung | Datum | Name | | | | | | | | | |

13.5 Project planning data

