

# SERVICE MANUAL

## **Controller SIGMA CONTROL**

Index: 7\_7000\_0-00 09 USE - BUB 80.XX

- 
- ▶ Foldout: control panel, display and indications

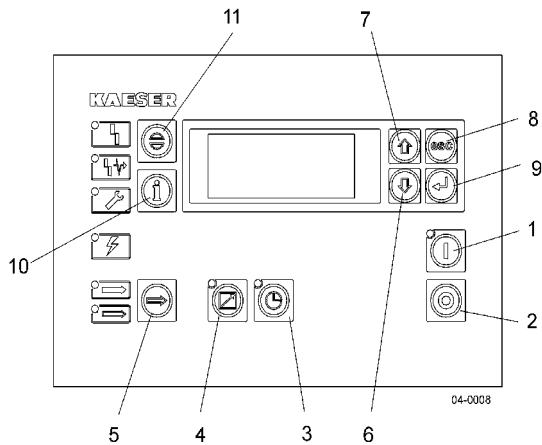

Symbol	Item	Key	Symbol	Item	Key
	1	ON		6,7	DOWN, UP
	2	OFF		8	Escape
	3	Clock		9	Enter
	4	Remote		10	Information
	5	LOAD/ IDLE		11	Reset

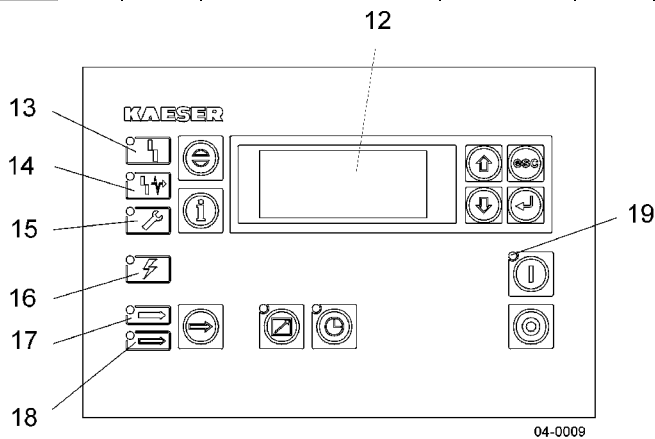

Symbol	Item	Description	Symbol	Item	Description
	12	Display		16	Controller power
	13	Alarm		17	LOAD mode
	14	Communication		18	IDLE mode
	15	Maintenance/ Warning		19	Machine ON

---

---

# QUICK USER GUIDE

## SIGMA CONTROL

7\_7000\_0-00 09 USE - BUB 80.XX



---

	Page
1. Important Settings .....	1
2. Changing Display Language .....	1
3. Entering the Password .....	2
4. Adjusting System Pressure Setpoint .....	3
5. Activating the Clock Key .....	4
6. Activating the remote key .....	5
7. Changing the Control Mode .....	6
8. Outputting Important Operational States of the Machine. ....	7
9. Resetting Maintenance Interval Hours Counters .....	8
10. Displaying Messages .....	9
11. Testing the Safety Relief Valve .....	10
12. Checking the Temperature Sensor and Shutdown Temperature Function .....	12

## 1. Important Settings

In this chapter, important or often used settings are explained in brief. Detailed information on function, configuration, fault removal and important instructions concerning safe operation are found in subsequent chapters.



Setting-up procedures and other work may only be carried out on the machine

- by persons trained on the machine/controller and persons instructed by and under the supervision of a specialist
- by specialists
- by authorized maintenance personnel.

## 2. Changing Display Language

1. In the main menu press the *UP* key until the required language appears.

88psi 180°F	1
	2
->english <	3 <i>current language</i>
- - - - -	4

2. Press the *Enter* key.
3. Keep on pressing the *DOWN* key or the *UP* key until the required language appears in the display.
4. Press the *Enter* key.  
The language is now set.
5. Press the *Escape* key as often as necessary to return to the main menu.



### 3. Entering the Password

The following passwords are entered in the controller on delivery:

- Password for level 0: **00000**
  - Password for level 4: **12EXP**
1. In the main menu, keep on pressing the *UP* key until `password` appears in the third line of the display.
  2. Press the *Enter* key.

88psi 180°F	1
password	2
XXXXX L0 <	3
XXXXX L0	4

3. Press the *Enter* key.  
The cursor flashes on the first character of the password XXXXX.
4. Keep on pressing the *DOWN* key or the *UP* key until the required character appears.
5. Press the *Enter* key.  
The flashing cursor jumps to the next character of the password.
6. Set the remaining characters of the password until it is complete.  
After entering the last character the activated password level is displayed.
7. Press the *Escape* key as often as necessary to return to the main menu.

**Further information:**

See chapter 7.1 for the configuration of the controller.

## 4. Adjusting System Pressure Setpoint

Select menu option configuration > pressure settings

Condition: password level 4 is activated.

1. In the main menu, keep on pressing the *UP* key until *configuration* appears in the third line of the display.
2. Press the *Enter* key.  
pressure settings appears in the display.
3. Press the *Enter* key.  
compressor appears in the display.
4. Press the *Enter* key.

88psi 180°F	1	
setpoint press.	2	
p1 SP: 80psi <	3	<i>actual p1 pressure setpoint (example)</i>
SD: -7.3psi	4	<i>actual p1 switching difference (example)</i>

**Setting system pressure setpoint and switching difference for p1**

5. Press the *Enter* key to adjust pressure setpoint p1.  
A flashing cursor appears in the display under p1 SP: 80psi
6. Adjust the value with the *UP* key or the *DOWN* key.
7. Press the *Enter* key to accept the value.
8. Press the *DOWN* key once.

88psi 180°F	1	
p1 SP: 88psi	2	<i>changed pressure setpoint</i>
SD: -7.3psi <	3	<i>actual p1 switching difference</i>
p2 SP: 104psi	4	<i>actual p2 pressure setpoint</i>

9. Press the *Enter* key to adjust switching difference p1.  
A flashing cursor appears in the display under p1 SD: -7.3psi.
10. Adjust the value with the *UP* key or the *DOWN* key.
11. Press the *Enter* key to accept the value.
12. If necessary, adjust the values for p2 in the same way.

**Further information:**

See chapter 7.2 for all machine pressure parameters and their adjustment.

## 5. Activating the *Clock* Key

### Select the clock menu option

Condition: password level 4 is activated.

1. In the main menu, keep on pressing the *UP* key until `clock` appears in the third line of the display.
2. Press the *Enter* key.

```
88psi 180°F 1
clock key n 2
reset: n < 3
- - - - - 4
```

### Activating the *clock* key

3. Press the *UP* key once.

```
88psi 180°F 1
2
clock key: n < 3
reset: n 4
```

4. Press the *Enter* key.  
A flashing cursor appears in the display.
  5. Press the *UP* key once.  
The display changes to `clock key y`.
  6. Press the *Enter* key.  
The *clock* key is activated and can be used.
- The *clock* key can be deactivated in the same way.

### Further information:

See chapter 7.3 for configuration of starting and stopping the machine.

See chapter 7.5.2 for configuration of p1/p2 load changeover based on a time schedule.

## 6. Activating the *remote* key



Further settings have to be made to allow the machine to be remotely controlled.

Refer, in this case, to the section **Further information** in this chapter.

### Select menu option configuration > pressure settings

Condition: password level 4 is activated.

1. In the main menu, keep on pressing the *UP* key until `configuration` appears in the third line of the display.
2. Press the *Enter* key.  
`pressure settings` appears in the display.

The *remote* key can be activated in two menu options: compressor start or load control.

### Activating the *remote* key in the compressor start menu option

1. Keep on pressing the *DOWN* key until `compressor start` appears in the third line of the display.
2. Press the *Enter* key.  
`compressor ON` appears in the third line of the display.
3. Press the *Enter* key again.
4. Keep on pressing the *DOWN* key until `remote key: n` appears in the third line of the display.
5. Press the *Enter* key.  
The cursor flashes below the `n` (*remote* key not activated).
6. Press the *UP* key.  
The display changes to `remote key y`.
7. Confirm the setting with the *Enter* key.  
The *remote* key is activated and can be used.
8. Press the *remote* key to enable remote mode.

The *remote* key can be deactivated in the same way.

### Activating the *remote* key in the load control menu option

1. Keep on pressing the *DOWN* key until `load control` appears in the third line of the display.
2. Press the *Enter* key.
3. Keep on pressing the *UP* or *DOWN* key until `remote-key: y/n` appears in the third line of the display.
4. Press the *Enter* key.  
The cursor flashes below the `y` (*remote* key active) or `n` (*remote* key inactive).
5. Use the *UP* key or *DOWN* key to select `y` and confirm with *Enter*.  
The *remote* key is activated and can be used.

The *remote* key can be deactivated in the same way.

### Further information:

See chapter 7.3 for configuration of starting and stopping the machine.

See chapter 7.6 for configuration of p1/p2 load changeover in sequenced mode.

## 7. Changing the Control Mode

### Select menu option configuration > control mode

Condition: password level 4 is activated.

1. In the main menu, keep on pressing the *UP* key until *configuration* appears in the third line of the display.
2. Press the *Enter* key.  
pressure settings appears in the display.
3. Press the *DOWN* key once, then the *Enter* key to select the control mode menu option.
4. Press the *Enter* key again.

### Changing the control mode

```
88psi 180°F 1
local mode 2
-> Quadro < 3 actual control mode
control mode 4
```

5. Select the control mode with the *UP* key or the *DOWN* key.
6. Press the *Enter* key to accept the control mode.
7. Press the *Escape* key as often as necessary to return to the main menu.

### Further information:

See chapter 4.7 for the functions of the control modes.

See chapter 7.4 for configuring the parameters of the control modes.

See chapter 8.15 to determine the optimal control mode.

## 8. Outputting Important Operational States of the Machine.

Important operational states of the machine can be assigned via contacts to outputs DO 0.3 – DO 0.5 as a binary signal. Further outputs are optionally available.

### Select menu options configuration > I/O periphery > DO functions

Condition: password level 4 is activated.

1. In the main menu, keep on pressing the *UP* key until `configuration` appears in the third line of the display.
2. Press the *Enter* key.  
`pressure settings` appears in the display.
3. Press the *DOWN* key until `I/O periphery` appears.
4. Press the *Enter* key twice to select menu option `DO functions`

<code>88psi 180°F</code>	<code>1</code>
<code>Controller ON</code>	<code>2 controller ON message</code>
<code>-&gt; n.a. &lt;</code>	<code>3 no output assigned</code>
<code>group alarm</code>	<code>4 group alarm message</code>

### Assigning a message to an output

5. Select the required message with the *UP* key or the *DOWN* key.
6. Press the *Enter* key.  
The cursor flashes below `n.a.` (or below the assigned output).
7. Use the *DOWN* key or the *UP* key to select a spare output and confirm by pressing *Enter*.  
A message is now sent via the output assigned.
8. Press the *Escape* key as often as necessary to return to the main menu.

### Further information:

See chapter 7.9 for configuration and use of the controller's inputs and outputs.

## 9. Resetting Maintenance Interval Hours Counters

Condition: maintenance task completed,  
service message reset,  
password level 4 is activated.

**Select menu option maintenance > maintenance interval hours counter (unit to be maintained, e.g. oil filter, bearing change, etc.)**

1. In the main menu, keep on pressing the *DOWN* key until maintenance appears in the third line of the display.
2. Press the *Enter* key.
3. The maintenance interval hours counter (e.g. oil filter) appears.

88psi 180°F	1
oil filter	2 Name of the maintenance interval hours counter
6000h   0150h <	3 preset interval / remaining hours
reset: n	4

4. Keep on pressing the *UP* or *DOWN* key until the unit to be maintained appears in the second line of the display.

### Resetting maintenance interval hours counters

5. Press the *DOWN* key.
6. Press the *Enter* key.  
The cursor flashes below reset n.
7. Use the *UP* key to select y and confirm with *Enter*.  
The interval hours remaining now change to the total hours of the maintenance interval, the reset parameter changes from y to n.
8. Press the *Escape* key as often as necessary to return to the main menu.

### Further information:

See chapter 8.11 for setting the maintenance intervals.

See chapter 10 for the maintenance of the controller.

## 10. Displaying Messages

### Select menu options status > messages

1. In the main menu keep on pressing the *DOWN* key until *status* appears in the third line of the display.
2. Press the *Enter* key.  
*messages* appears in the display.
3. Press the *Enter* key.  
*event info* appears in the display.

### Displaying event information

4. Press the *Enter* key.  
The last message (event) displayed appears in the display. The messages are displayed chronologically.
5. Scroll through historical events with the *DOWN* key and back to current events with the *UP* key.
6. Press the *Escape* key as often as necessary to return to the main menu.

### Displaying the last alarm

Condition: menu option status > messages is selected

1. Keep on pressing the *DOWN* key until *last alarm:* appears in the third line of the display.
2. Press the *Enter* key.  
The last alarm is displayed.
3. Press the *Escape* key as often as necessary to return to the main menu.

### Displaying the last warning

Condition: menu option status > messages is selected

1. Keep on pressing the *DOWN* key until *last warning:* appears in the third line of the display.
2. Press the *Enter* key.  
The last warning is displayed.
3. Press the *Escape* key as often as necessary to return to the main menu.

### Displaying the number of current alarms or warnings

Condition: menu option status > messages is selected

1. Keep on pressing the *DOWN* key until number of current alarms and warnings appears.
2. Press the *Escape* key as often as necessary to return to the main menu.

### Further information:

See chapter 8.2 to reset alarms

See chapter 8.3 to reset warnings



## 11. Testing the Safety Relief Valve

**WARNING**

**Compressed air is dangerous!**

- ▶ The instructions listed below must be followed.

### Preparation for the test

1. Ascertain from the machine's nameplate the opening pressure (or activating pressure) of the safety relief valve and write it down.
2. Press the *OFF* key to shut down the machine.
3. Close the shut-off valve supplying the compressed air network from the machine.
4. Activate password level 4 in the controller (see chapter 3.).
5. In the main menu, press the *UP* key as often as necessary until `package test` appears in the third line of the display.
6. Press the *Enter* key.  
TÜV check appears in the display.
7. Press the *Enter* key.

88psi 180°F	1	
TÜV check	2	
relief valve: n <	3	
pRV: 230 psi	4	<i>activating pressure of pressure relief valve (example)</i>

8. Press the *Enter* key.  
The cursor flashes below `relief valve: n`.

### Carrying out the test

9. Use the *UP* key to select `y` and confirm with *Enter*.  
The "safety relief valve" check mode is activated. Monitoring of internal pressure and system setpoint pressure is deactivated!
10. Press the *DOWN* key once to display the internal pressure:

88psi 180°F	1	
relief valve: y	2	
pRV: 230 psi <	3	<i>activating pressure of the safety relief valve</i>
pi : 36.3 psi	4	<i>actual internal pressure</i>
11. Press and hold the *ON* key.  
The machine switches to load, the internal pressure `pi` of the machine rises.
12. Keep an eye on the rise in `pi` on the display as long as the test is running.
13. If pressure `pi` rises to 10 % above the activating pressure of the relief valve shut down the machine with the *OFF* key and replace the safety relief valve.



Avoiding oil mist:

- ▶ Release the *ON* key as soon as the safety relief valve opens to keep build-up of oil mist as low as possible.



If the **pRV^** alarm appears in the display, the safety relief valve is defective. The permissible internal pressure was exceeded by 2 psi.

- ▶ Have the safety relief valve replaced by an authorized KAESER Service agent.

**Due conclusion of the test**

14. Press the *UP* key once.

15. Press the *Enter* key.

The cursor flashes below `relief valve: y`.

16. Use the *DOWN* key to select `n` and confirm with *Enter*.

The "pressure relief valve" check mode is de-activated and the test ended.

17. Press the *Escape* key as often as necessary to return to the main menu.

18. Open the shut-off valve from the machine again.

The machine is ready for operation.

**Further information:**

See chapter 8.13 to test the safety relief valve.

## 12. Checking the Temperature Sensor and Shutdown Temperature Function

### Ascertaining offset

1. Read off the airend-discharge temperature under load (normal working temperature) (first line in the display, e.g.: 180 °F)
2. Offset = 230 °F minus the airend discharge temperature (offset in this case = 50 °F)
3. Shut down the machine with the *OFF* key
4. Watch the first line of the display and wait until the airend discharge temperature has dropped by about 15 °F

### Setting the offset

5. Activate password level 4 in the controller (see chapter 3.).
6. In the main menu, keep pressing the *UP* key until `package test` appears in the third line of the display.
7. Press the *Enter* key.  
"TÜV inspection" appears in the display.
8. Keep pressing the *DOWN* key until the following is displayed:

88psi 180°F	1
ADT alarm: n	2 Shutdown temperature
Offset: 40 °F <	3 Offset value set (example)
ADT ^ : 0 °F	4

9. Press the *Enter* key.  
The cursor flashes below `offset: 40°F`.
10. Use the *DOWN* key or the *UP* key to set the calculated offset and confirm by pressing *Enter*.

### Carrying out the test

Condition: the machine has cooled down by about 15 °F

11. Press the *UP* key once so that `ADT alarm: n` appears in the third line of the display.
12. Press the *Enter* key.  
The cursor flashes under `ADT alarm: n`.
13. Use the *UP* key to select `y` and confirm with *Enter*.  
The "ADT alarm" check mode is activated.
14. Press the *DOWN* key once to display working temperature + offset:

88psi 160°F	1 Lowered working temperature (160 °F).
ADT alarm: y	2 Shutdown temperature
Offset: 50 °F <	3 Offset value set (example)
ADT ^ : 210 °F	4 Working temperature + offset

15. Press the *ON* key to switch the machine to *LOAD*.  
The machine runs on load and the airend discharge temperature rises to the working temperature again.  
If the ADT reaches 230 °F the machine should shut down after two seconds and an alarm displayed.



The machine does not shut down:

- ▶ Abort the test and contact KAESER Service as soon as possible.

**Due conclusion of the test**

16. Press the *Enter* key.
17. Reset the offset to 40 ° F and confirm with *Enter*.
18. Deactivating ADT alarm check mode: press the *UP* key once so that ADT alarm: y appears in the third line of the display.
19. Press the *Enter* key.
20. Use the *UP* key to select n and confirm with *Enter*.  
The "Shutdown temperature" check mode is de-activated and the test ended.
21. Press the *Escape* key as often as necessary to return to the main menu.

**Further information:**

See chapter 8.14 for testing the temperature sensor.

<b>1</b>	<b>Regarding this Document</b>	<b>1 – 1</b>
1.1	Using the Document	1 – 1
1.2	Copyright	1 – 1
1.3	Symbols and Identification	1 – 1
1.4	Graphic portrayal of the display	1 – 2
<b>2</b>	<b>Technical Specification</b>	<b>2 – 3</b>
2.1	Power Supply	2 – 3
2.2	Sensors	2 – 3
2.3	Hardware	2 – 3
2.4	Inputs and Outputs	2 – 3
<b>3</b>	<b>Safety and Responsibility</b>	<b>3 – 4</b>
3.1	Specified Use	3 – 4
3.2	Unspecified Use	3 – 4
3.3	User's Responsibilities	3 – 4
3.4	Hazards	3 – 5
3.5	Safety Regulations for the Controller	3 – 5
<b>4</b>	<b>Design and Function</b>	<b>4 – 6</b>
4.1	Short Description of the Controller	4 – 6
4.2	Keys and LEDs	4 – 7
4.2.1	Keys	4 – 7
4.2.2	LEDs	4 – 8
4.2.3	The Display	4 – 9
4.3	Password Protection	4 – 10
4.4	Short Description of the Menu Structure	4 – 10
4.4.1	Main menu	4 – 10
4.4.2	The two navigation levels in SIGMA CONTROL	4 – 11
4.5	Outline of the Display and Setup Level	4 – 11
4.5.1	Configuration menu	4 – 12
4.5.2	Components menu	4 – 14
4.5.3	Package test menu	4 – 14
4.5.4	Communication menu option	4 – 15
4.6	Outline of the Display Level	4 – 16
4.7	Operating and Control Modes	4 – 18
4.7.1	Machine operating modes	4 – 18
4.7.2	Control modes	4 – 18
4.7.3	Variable speed drive with frequency converter (SFC)	4 – 19
4.8	MODULATING Control Mode	4 – 19
<b>5</b>	<b>Installation and Operating Conditions</b>	<b>5 – 20</b>
5.1	Installation Site	5 – 20
5.2	Installation Conditions	5 – 20
<b>6</b>	<b>Installation</b>	<b>6 – 21</b>
6.1	Reporting Transport Damage	6 – 21
6.2	Machine Identification	6 – 21

<b>7</b>	<b>Initial Start–up .....</b>	<b>7 – 22</b>
7.1	Configuring the Controller .....	7 – 23
7.1.1	Selecting menu options .....	7 – 23
7.1.2	Changing display language .....	7 – 23
7.1.3	Entering and displaying passwords .....	7 – 23
7.1.4	Setting up time and date .....	7 – 24
7.1.5	Setting display formats .....	7 – 25
7.1.6	Setting and activating Summer/Winter time .....	7 – 28
7.1.7	Activating/deactivating the IDLE mode .....	7 – 29
7.2	Configuring the pressure settings .....	7 – 29
7.2.1	List of pressure parameters .....	7 – 30
7.2.2	Displaying pressure parameters .....	7 – 31
7.2.3	Configuring the pressure parameters for compressors .....	7 – 32
7.2.4	Configuring the pressure parameters for vacuum pumps .....	7 – 34
7.2.5	Configuring pressure parameters for boosters and air main charging compressors .....	7 – 35
7.3	Configuring machine start and stop .....	7 – 36
7.3.1	Automatic start/stop in programmed clock mode .....	7 – 37
7.3.2	Setting up the holiday period .....	7 – 39
7.3.3	Starting the machine remotely from a control centre (remote ON/OFF) ..	7 – 40
7.3.4	Activating/deactivating the IDLE phase (venting function) .....	7 – 42
7.3.5	Activating/deactivating and setting up automatic restart after a power failure .....	7 – 42
7.3.6	Setting up the delays for star-delta-start .....	7 – 44
7.4	Activating and setting up the control modes .....	7 – 44
7.4.1	Selecting control modes DUAL/QUADRO/VARIO/CONTINUOUS .....	7 – 44
7.4.2	Setting up the IDLE period in DUAL control .....	7 – 45
7.4.3	Setting the unloaded and minimum running period in QUADRO control mode .....	7 – 45
7.4.4	Setting up the control pressure valve for MODULATING control mode ...	7 – 46
7.5	Configuring the machine for local mode .....	7 – 47
7.5.2	Configuring the system pressure setpoint changeover using the clock. ...	7 – 47
7.5.3	Configuring the system pressure setpoint changeover using the timer. ...	7 – 49
7.6	Configuring the machine for operation in sequence .....	7 – 51
7.6.2	Configuring Profibus mode (SAM or VESIS) .....	7 – 52
7.6.3	Configuring the Profibus interface without SAM/VESIS .....	7 – 56
7.6.4	Configuring master-slave mode .....	7 – 57
7.6.5	Configuring sequencing mode using the LOAD remote contact (e.g. MIC 4000) .....	7 – 64
7.6.6	Configuring sequencing mode using the local/remote contact (e.g. MVS 8000) .....	7 – 65
7.6.7	Configuring the sequencing mode from the remote contact .....	7 – 68
7.6.8	Sequencing mode with machines controlled by the pressure switch .....	7 – 69
7.7	Configuring PC or Modem Output .....	7 – 75
7.7.2	Configuring the RS 232 interface .....	7 – 76

	Chapter – page
7.8	Configuring the SMS ..... 7 – 76
7.8.1	Activating the SMS function ..... 7 – 77
7.8.2	Suppress repeat messages (filter) ..... 7 – 77
7.8.3	Entering the modem's phone number (modem) ..... 7 – 78
7.8.4	Entering company data (site location) ..... 7 – 78
7.8.5	Configuring selection of the Service Centre (channel) ..... 7 – 79
7.9	Configuring input and output signals ..... 7 – 80
7.9.1	Outputting important operational states of the machine. .... 7 – 80
7.9.2	Displaying analog input values ..... 7 – 81
7.9.3	Displaying additional binary input signals ..... 7 – 83
7.9.4	Using machine pressure and temperature values as switches ..... 7 – 85
7.9.5	Configuring analog outputs ..... 7 – 87
7.10	Configuring the Package Discharge Air Temperature ..... 7 – 89
7.10.1	Compensating line resistance ..... 7 – 89
7.10.2	Entering the correction value ..... 7 – 90
7.10.3	Switching levels for the package discharge temperature ..... 7 – 90
7.11	Activating Remote Reset ..... 7 – 91
7.11.1	Selecting menu option configuration > acknowledgement ..... 7 – 91
7.11.2	Setting the remote reset function ..... 7 – 92
7.11.3	Activating the remote key ..... 7 – 92
7.11.4	Assign an input ..... 7 – 92
7.12	Linking to an external pressure transducer ..... 7 – 92
7.12.1	Selecting menu option configuration > pressure settings > load control . 7 – 93
7.12.2	Assign an input ..... 7 – 93
7.12.3	Defining the type of analog signal (4 - 20 mA/0 - 20 mA) ..... 7 – 93
7.13	Setting up the timer for condensate drainage ..... 7 – 93
7.13.1	Selecting menu option configuration > timer ..... 7 – 94
7.13.2	Setting the timer OFF and timer ON periods ..... 7 – 94
7.13.3	Assigning an output to the solenoid valve ..... 7 – 94
7.14	Activating the energy–saving mode for the refrigeration dryer ..... 7 – 94
7.15	Initial Start–up ..... 7 – 95
<b>8</b>	<b>Operation ..... 8 – 96</b>
8.1	Switching the Machine On and Off ..... 8 – 96
8.1.1	Switching on the machine in local mode ..... 8 – 96
8.1.2	Switching off the machine in local mode ..... 8 – 97
8.1.3	Remote on and off switching ..... 8 – 97
8.1.4	Switching on and off with the clock ..... 8 – 97
8.2	Resetting alarm messages ..... 8 – 98
8.3	Resetting warning messages ..... 8 – 99
8.4	Displaying the Actual Operating Mode ..... 8 – 99
8.5	Setting up Machine Pressure ..... 8 – 100
8.6	Displaying Messages ..... 8 – 100
8.6.1	Selecting menu option status > messages ..... 8 – 101
8.7	Displaying status data, resetting and printing ..... 8 – 102
8.7.1	Displaying and resetting machine duty cycle ..... 8 – 102

	Chapter – page
8.7.2	Displaying and resetting further status data ..... 8 – 103
8.7.3	Changing the permissible number of motor starts ..... 8 – 103
8.7.4	Transferring event memory data or parameter data to a PC ..... 8 – 104
8.8	Displaying analog data ..... 8 – 104
8.9	Displaying operating data ..... 8 – 105
8.10	Resetting maintenance interval hours counters ..... 8 – 106
8.11	Setting the maintenance interval ..... 8 – 107
8.12	Resetting annual maintenance messages ..... 8 – 108
8.13	Checking the safety relief valve ..... 8 – 108
8.14	Checking the Temperature Sensor and Overtemperature Shutdown Function ..... 8 – 110
8.15	Determining the optimal control mode. .... 8 – 112
<b>9</b>	<b>Fault Finding and Removal ..... 9 – 113</b>
9.1	Alarm messages to the controller (machine shut-down, red LED blinking) ..... 9 – 113
9.2	Warning messages on the controller (yellow LED flashes) ..... 9 – 116
9.3	Other Alarms ..... 9 – 119
<b>10</b>	<b>Maintenance ..... 10 – 121</b>
10.1	Testing the controller ..... 10 – 121
10.1.1	Displaying binary inputs and outputs ..... 10 – 121
10.1.2	Testing the LEDs on the controller ..... 10 – 121
<b>11</b>	<b>Spares, Operating Materials, Service ..... 11 – 123</b>
11.1	Note the nameplate ..... 11 – 123
11.2	Maintenance Contract ..... 11 – 123
11.3	Service Addresses ..... 11 – 123
11.4	Displaying the version number, machine model, material number and serial number ..... 11 – 123
<b>12</b>	<b>Decommissioning, Storage and Transport ..... 12 – 124</b>
<b>13</b>	<b>Annex ..... 13 – 125</b>



Fig. 1	The function keys on SIGMA CONTROL .....	4 – 7
Fig. 2	SIGMA CONTROL LEDs .....	4 – 8
Fig. 3	Wiring the Profibus plug .....	7 – 52
Fig. 4	Example of connections for sequencing with SAM .....	7 – 53
Fig. 5	Electrical connections between the two controllers .....	7 – 59
Fig. 6	LOAD remote contact wiring diagram .....	7 – 64
Fig. 7	Wiring diagram for local/remote contact .....	7 – 66
Fig. 8	Wiring diagram for machine with pressure switch regulation .....	7 – 70
Fig. 9	Function diagram of pressure switch regulation and SIGMA CONTROL regulation .....	7 – 72
Fig. 10	Switching On and Off .....	8 – 96
Fig. 11	Resetting warning and alarm messages .....	8 – 98
Fig. 12	Resetting warning and alarm messages .....	8 – 99

Tab. 1	SIGMA CONTROL function keys .....	4 – 7
Tab. 2	SIGMA CONTROL LEDs .....	4 – 8
Tab. 3	Internal operating modi .....	4 – 9
Tab. 4	Characters in the navigation line .....	4 – 9
Tab. 5	Outline of the Display and Setup Level .....	4 – 11
Tab. 6	Configuration menu .....	4 – 13
Tab. 7	Components menu .....	4 – 14
Tab. 8	Package test menu .....	4 – 14
Tab. 9	Communication menu .....	4 – 15
Tab. 10	Outline of the Display Level .....	4 – 17
Tab. 11	Date format .....	7 – 25
Tab. 12	time formats .....	7 – 26
Tab. 13	Units of pressure .....	7 – 27
Tab. 14	Units of temperature .....	7 – 27
Tab. 15	Pressure parameters of the compressors .....	7 – 30
Tab. 16	Pressure parameters for rotary screw vacuum pumps .....	7 – 31
Tab. 17	Pressure parameters for the components .....	7 – 31
Tab. 18	Example of a machine ON/OFF clock program .....	7 – 38
Tab. 19	Operating modes in local mode .....	7 – 47
Tab. 20	Example of system pressure changeover switching points .....	7 – 48
Tab. 21	Table of controllers working in sequence .....	7 – 51
Tab. 22	Profibus DP pin assignments .....	7 – 52
Tab. 23	Master-slave configuration procedure .....	7 – 58
Tab. 24	RS 485 pin assignment .....	7 – 58
Tab. 25	Example switching points .....	7 – 73
Tab. 26	Example clock program for equal duty cycling during the day .....	7 – 75
Tab. 27	Example clock program for equal duty cycling during the week .....	7 – 75
Tab. 28	RS 232 pin assignment .....	7 – 76
Tab. 29	Assigned output signals .....	7 – 80
Tab. 30	Checklist of installation conditions .....	7 – 95
Tab. 31	Displayed analog data .....	8 – 105
Tab. 32	Alarm messages and actions .....	9 – 116
Tab. 33	Warning messages and actions .....	9 – 119
Tab. 34	Other faults and actions .....	9 – 120

## 1 Regarding this Document

### 1.1 Using the Document

This service manual is part of the controller.

The chapter "Important Settings" is a guide to making settings that are important or often needed. It can be separated from the manual by tearing along the perforated line.

A graphic representation of the control panel and the menu tree are shown on the fold-out pages at the beginning and end of the service manual.

- ▶ Keep the service manual available as long as work is done on the controller.
- ▶ Pass the manual on to the next owner/user of the machine.
- ▶ Make sure that every subsequent modification to the controller is also entered in the service manual.

### 1.2 Copyright

This service manual is protected by copyright. Please contact KAESER if you have any queries regarding the use and duplication of this documentation. We will gladly help you in the appropriate use of the information.

### 1.3 Symbols and Identification

The following signs and symbols have been used in this service manual:

#### Warnings

Example:



**DANGER**

**This is a hazard warning.**

The possible consequences of ignoring a hazard warning are shown here.

- ▶ Measures for avoiding such a hazard are given here.

#### Hazard levels:

Warnings are divided into three hazard levels signified by the signal word below the hazard symbol.

Signal word	Meaning	Consequence
DANGER	Warning of an imminent threat of danger	Death or grievous bodily harm may result
WARNING	Warning of a possible threat of danger	Death or grievous bodily harm and/or serious damage to the controller is possible
CAUTION	Warns of a possibly hazardous situation	Light injury or material damage is possible



This character refers to important information. Pointers are given here concerning procedures and useful additional information.



This symbol identifies environmental protection measures.

**Condition:** Stipulations are listed that have to be satisfied before action is taken.

- ▶ This bullet is part of a list of instructions comprising one stage of action.
- 1. Where several stages of action are concerned each individual step is numbered.

#### 1.4 Graphic portrayal of the display

After pressing the *Enter* key, the result of the action is shown as follows (example):

Portrayal	<i>additional comments</i>
88 psi 180 °F	1
-> 2004/07/23	2 <i>actual date</i>
-> 16:10:31 <	3 <i>actual time, entry line &lt;</i>
...	4

## 2 Technical Specification

The power supply is fed from a power supply unit in the machine.

### 2.1 Power Supply

Rated voltage	24 V DC (stabilised)
Current flow (standard controller):	1.3 A
Current flow with expansion card:	2.5 A

### 2.2 Sensors

#### Pressure transducer:

Output signal:	4–20 mA
Connection:	2–wire

#### Resistance thermometer:

Sensing resistance	PT100 (to DIN IEC 751)
Connection:	2–wire

### 2.3 Hardware

#### Industrial computer

- Internal temperature monitoring
- Internal low volts monitoring of the 24 V supply

### 2.4 Inputs and Outputs



The number of inputs and outputs is linked to the type of controller used. DO 0.3 - DO 0.5 are always available as spare outputs. Further details concerning inputs and outputs are to be found in the electrical diagrams of the machine.

#### Interfaces

- RS 232
- RS 485
- Profibus-DP

### 3 Safety and Responsibility

**WARNING****Risk of serious injury or death**

Disregard of the following information can result in serious injury.

- ▶ Please read and pay attention to the following information.

The controller is manufactured to the latest engineering standards and acknowledged safety regulations. Nevertheless, risk of injury and death to the user and third parties or adverse effects to the controller and other material damages can arise from its use.

Use the controller only if it is in technically perfect condition for the purpose for which it is intended under compliance with the safety measures and instructions detailed in the service manual.

In particular, immediately rectify (have rectified) any faults that could be detrimental to safety.

#### 3.1 Specified Use

The controller is intended exclusively for the operation of KAESER compressors in fields of industry and may only be operated within the machine. Any other use is considered incorrect. The manufacturer is not liable for any damages resulting from unspecified use or application. The risk involved in such unspecified use is taken solely by the user.

Correct use also includes compliance with the instructions contained in this service manual.

#### 3.2 Unspecified Use

Do not expose the controller to direct sunlight, rain, water, or very dusty conditions.

#### 3.3 User's Responsibilities

**Personnel**

Only specialists or personnel trained to use the controller may carry out any work on it. This applies particularly to:

- installation and initial start-up
- maintenance and service work
- repairs
- inspections

Allow only qualified electricians or trained personnel under the supervision of a qualified electrician to work according to electrical engineering regulations on electrical equipment.

Ensure that all persons working on the controller have read and understood and that they comply with the safety instructions and the passages relevant to them in the service manual.

Give clear instructions on reporting faults and damage to the controller.

Observe relevant statutory legislation during installation, operation, maintenance and repair of the controller. For example, nationally applied European directives and/or valid national legislation, safety and accident prevention regulations.

### 3.4 Hazards

#### Basic rule: comply with accepted regulations

- ▶ Observe all accepted safety regulations and national legislation applicable to all work carried out on the controller.

Examples of these are directives and national regulations concerning safety and accident prevention.

#### Electrical hazards



**DANGER**

#### Electricity!

There is danger of fatal injury caused by touching electrically live components.

- ▶ Observe all accepted safety regulations and national legislation applicable to all work carried out on the controller.

Work on the electrical equipment may only be carried out by a qualified electrician or by trained personnel under the supervision of a qualified electrician.

Comply with the accepted regulations for safety at work when carrying out work on electrical equipment.

Before the machine is switched on for the first time the user is to provide measures to guard against electric shock caused by direct or indirect contact and is to check these measures for effectiveness:

1. Isolate all phases of the main power supply (switch off the supply disconnecting (isolating) device).
2. Ensure that the power supply cannot be switched on again (lock out).
3. Check that no voltage is present.
4. Work carefully.



Before switching on again, ensure that

- no maintenance personnel are working on the machine,
- all panels are in place and secured,
- all access doors are closed.

### 3.5 Safety Regulations for the Controller

Pay attention to the following points to avoid damage to the controller:

- Do not remove any controller plugs when the machine is in operation.
- Operate the controller only when all supplies are connected.
- Do not apply other voltages (i.e. external supplies) to the electronic outputs in the output plugs.
- Do not short circuit the supply pins of the Profibus interface. A short circuit can cause irreversible damage to the profibus interface.

## 4 Design and Function

### 4.1 Short Description of the Controller

The controller controls, regulates, monitors and protects the machine.

All parameters needed to operate KAESER rotary screw compressors and rotary vacuum pumps can be entered and displayed using the controller. The parameters are protected by passwords at various access levels.

#### Components

SIGMA CONTROL is made up of the following components:

- industrial computer with Intel® processor
- software, with which the settings can be called up and altered
- integrated interface software with which data can be transferred over a Profibus
- a user interface with illuminated display, keys and light-emitting diodes
- digital and analog inputs and outputs

#### Function

The **control and regulating function** allows:

- automatic changeover of the machine from LOAD to IDLE or STANDSTILL
- optimum utilization of the drive motor in relation to the user's actual air demand
- automatic restart of the machine after a power failure (can be deactivated)

The **monitoring function** allows:

- monitoring of compressor components with maintenance hours counters
- warning and maintenance prompts in the controller's display for maintenance due
- punctual maintenance prompts for oil filter, air filter, V-belts (or coupling), drive motor bearings, electrical equipment and other components

The **protective function** allows:

- automatic machine shutdown on alarms that may lead to damage to the machine, e.g. overcurrent, overpressure, overtemperature



**4.2 Keys and LEDs**

(see foldout)

**4.2.1 Keys**

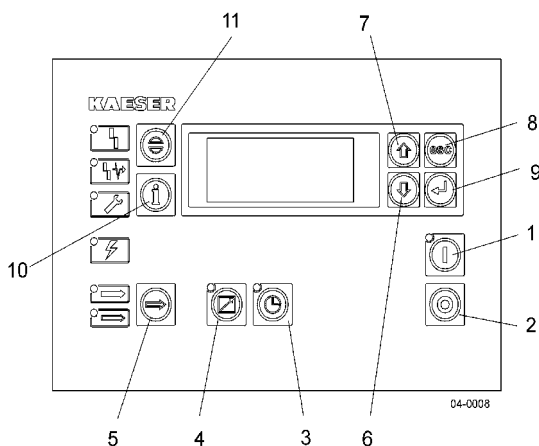

Fig. 1 The function keys on SIGMA CONTROL

Symbol	Item	Key	Function
	1	ON	<ul style="list-style-type: none"> <li>Switches on the machine.</li> <li>Programmed operating mode is active.</li> </ul>
	2	OFF	<ul style="list-style-type: none"> <li>Switches off the machine.</li> </ul>
	3	Clock	<ul style="list-style-type: none"> <li>Switches clock control on and off.</li> <li>The LED lights when the machine is under clock control.</li> </ul>
	4	Remote	<ul style="list-style-type: none"> <li>Switches remote control on and off.</li> <li>The LED illuminates when the machine is under remote control.</li> </ul>
	5	LOAD/ IDLE	<ul style="list-style-type: none"> <li>Toggles the machine between LOAD and IDLE.</li> </ul>
	6	DOWN	<ul style="list-style-type: none"> <li>Scrolls down menu options.</li> <li>Reduces a parameter value.</li> </ul>
	7	UP	<ul style="list-style-type: none"> <li>Scrolls up the menu options.</li> <li>Increases a parameter value.</li> </ul>
	8	Escape	<ul style="list-style-type: none"> <li>Returns to the next higher menu option level.</li> <li>Exits the edit mode without saving.</li> </ul>
	9	Enter	<ul style="list-style-type: none"> <li>Enters the selected menu option.</li> <li>Exits the edit mode and saves.</li> </ul>
	10	Information	<ul style="list-style-type: none"> <li>Displays the event memory.</li> <li>Available in all menus.</li> <li>Return to menu option with the escape key (8).</li> </ul>
	11	Reset	<ul style="list-style-type: none"> <li>Acknowledges (resets) alarm, maintenance and warning messages and resets the event memory (if possible).</li> </ul>

Tab. 1 SIGMA CONTROL function keys

4.2.2 LEDs

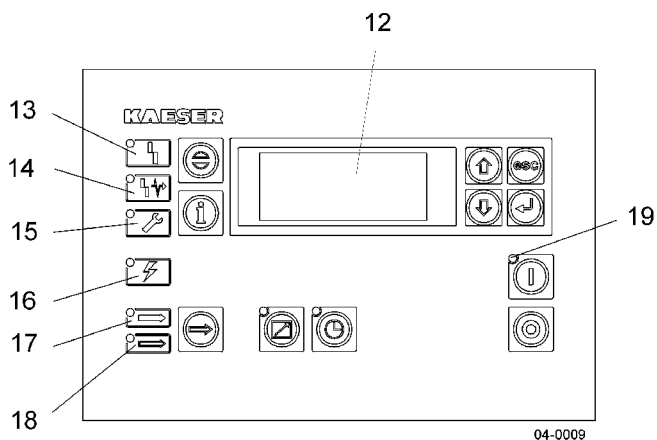

Fig. 2 SIGMA CONTROL LEDs

Symbol	Item	Description	Function
	12	Plain text display	Alphanumeric 4 line display.
	13	Alarm	Flashes red when an alarm occurs. Lights red continuously when acknowledged.
	14	Communication	Lights red if communication via the Profibus interface is interrupted.
	15	Maintenance and warning LED	Flashes yellow if: – maintenance work is due – there is a warning message Lights yellow continuously when acknowledged.
	16	Controller power	Lights green when the power supply to the controller is switched on.
	17	LOAD mode	Lights green when the machine is on LOAD
	18	Operating mode <i>IDLE</i>	Lights green when the machine is in IDLE mode. Flashes if the manual <i>mode</i> LOAD/IDLE key is pressed (5).
	19	Machine ON	The machine is switched on.

Tab. 2 SIGMA CONTROL LEDs

### 4.2.3 The Display

The display is used for the display and entry of data. The display comprises four lines with 16 characters each.

88 psi 180 °F	Header
Key ON   p1-idle	Machine status/Menu texts
run 000032 h	active line
load 000031 h	menu text

#### Line 1: header

Actual system pressure and airtend discharge temperature are displayed in the header. These values appear:

- in the main menu
- in set-up levels in which parameter changes can be made even though the machine is running

The letters S and F can be displayed in the header. They indicate internal operational modes and are shown for maintenance purposes.

Letter	Operational mode
S	Controller set to "stop" by the administrator from the programming unit
F	Program error (fault)

Tab. 3 Internal operating modi

#### Line 2: Machine status/menu text

Depending on settings, either the actual status of the machine or menu text is shown in line 2.

#### Line 3: Active line

The appropriate menu text/sub-option text or the menu option is shown in line 3.



Only the actions shown in the active line can be executed. This applies both to a jump to a menu option/sub-option and the alteration of values.

#### Line 4: Menu text

The characters below appear at the end of line 4 behind the menu option text and indicate the possible scrolling direction with the UP or DOWN keys.

Character	Explanation
↵	Appears at the end of the line if it is possible to jump to a sub-option or parameters can be entered
↑	Only an upwards scroll is possible with the UP key
↓	Only a downwards scroll is possible with the DOWN key
↕	Scrolling in both directions is possible

Tab. 4 Characters in the navigation line

### 4.3 Password Protection

Access to the controller is protected by password.

When the controller is switched on, the lowest level of access (Password Level 0) is activated. In Password Level 0 parameters can be displayed (Display Level) and certain parameters can be set (Display and Setup Level) e.g. language and time.

A further access level (Level 4) is available to the customer. Further parameters can be displayed and set in Level 4, for example, the system pressure setpoint or reset of the maintenance interval counters.



The Password-Level automatically resets to Level 0 within a period of three hours.

The following passwords have been entered in the controller at the factory:

- Password for Level 0: **00000**
- Password for Level 4: **12EXP**

### 4.4 Short Description of the Menu Structure



A list of Setup and Display Levels is shown in the foldout at the end of this manual.

#### 4.4.1 Main menu

When the machine is switched on, details of the software are displayed.

Example:

PN :	7.7000.0	<i>material number</i>
SN:	00234006	<i>serial number</i>
Sys:	S5:	HW:
4.46	80.00	019
		<i>system software hardware</i>
		<i>version version version</i>

Subsequently, the software is booted and the main menu appears in the display together with actual system pressure, aircend discharge temperature and actual machine status.

88psi	180 °F	<i>system pressure and aircend discharge temperature</i>
- - - - -		
	off	<i>operational mode (actual state of the machine)</i>
- - - - -		

After pressing the *DOWN* key three times the operational state of the machine, total operating hours and the hours on load appears.

88psi	180 °F	
Key ON	p1-idle	<i>operational status</i>
run	000032h	<i>total operating hours</i>
load	000031h	<i>total hours on load</i>

The operational state in the second line of the display shows the following settings:

- compressor on/off switching
- compressor status
- type of load control
- the load control status

#### 4.4.2 The two navigation levels in SIGMA CONTROL

In the main menu, scroll upwards with the *UP* key to enter the *Display and Setup Level*. Preprogrammed machine parameters can be displayed and changed in the Display and Setup Level.

In the main menu, scroll downwards with the *DOWN* key to enter the *Display Level*. At this level, parameters can only be displayed or reset.

#### 4.5 Outline of the Display and Setup Level

The Display and Setup Level comprises the following menus:

Menu options	Sub options	Menu option: see
Password	Enter password	–
Clock	<ul style="list-style-type: none"> <li>– Activation of the <b>Clock</b> key</li> <li>– Timing of compressor cut-in and cut-out (switching points)</li> <li>– Reset timing</li> </ul>	–
Configuration	<ul style="list-style-type: none"> <li>– General</li> <li>– Pressure settings</li> <li>– Control mode</li> <li>– Compressor start</li> <li>– Reset</li> <li>– I/O periphery</li> <li>– Timer</li> </ul>	4 – 12
Components	<ul style="list-style-type: none"> <li>– Motor</li> <li>– Booster</li> <li>– Air main charging</li> <li>– PD temperature</li> </ul>	4 – 14
Package test	<ul style="list-style-type: none"> <li>– TÜV check</li> <li>– Binary inputs</li> <li>– Binary outputs</li> <li>– Lamps test</li> </ul>	4 – 14
Communication	<ul style="list-style-type: none"> <li>– RS 232</li> <li>– RS 485</li> <li>– Profibus</li> <li>– SMS</li> </ul>	4 – 15
Languages	Selecting the displayed language	–

Tab. 5 Outline of the Display and Setup Level

**4.5.1 Configuration menu**

The parameters for configuration of the controller and the machine are set up in the configuration menu option. The menu option has the following sub-options:

- General
- Pressure settings
- Control mode
- Compressor start
- Reset
- I/O periphery
- Timer

Navigation (option/sub-option)	Function
General	Display: <ul style="list-style-type: none"> <li>- Version No.</li> <li>- Model</li> <li>- PN: (material number)</li> <li>- SN:(serial number)</li> </ul> Settings: <ul style="list-style-type: none"> <li>- Date</li> <li>- Time</li> <li>- Summer/Winter time</li> <li>- Date format</li> <li>- Time format</li> <li>- Unit of pressure</li> <li>- Unit of temperature</li> </ul>
Pressure settings <ul style="list-style-type: none"> <li>&gt; Compressor</li> <li>&gt; System pressure</li> </ul>	Display: <ul style="list-style-type: none"> <li>- Activating pressure (pRV)</li> <li>- Nominal pressure</li> <li>- Min. cut-in pressure</li> </ul> Settings: <ul style="list-style-type: none"> <li>- Pressure setpoints p1 and p2</li> <li>- System pressure low</li> <li>- Pressure increase pE</li> </ul>
Pressure settings <ul style="list-style-type: none"> <li>&gt; Vacuum package</li> <li>&gt; Vacuum package</li> </ul>	Settings: <ul style="list-style-type: none"> <li>- System pressure high</li> <li>- Setpoint press.</li> <li>- Pressure fall pA</li> </ul>
Pressure settings <ul style="list-style-type: none"> <li>&gt; Load control</li> </ul>	Settings: <ul style="list-style-type: none"> <li>- Local mode</li> <li>- Remote mode</li> </ul>
Control mode	Settings: <ul style="list-style-type: none"> <li>- Dual</li> <li>- Quadro</li> <li>- Vario</li> <li>- Continuous</li> </ul>
Control mode <ul style="list-style-type: none"> <li>&gt; Settings</li> <li>&gt; Dual</li> </ul>	Settings: <ul style="list-style-type: none"> <li>- idle period</li> </ul>

Navigation (option/sub-option)	Function
Control mode > Settings > Quadro	Settings: – Min run period – Unloaded period
Control mode > Settings	Settings: – Venting period
Control mode > Refrigeration dryer > Timer	Settings: – OFF period – ON period – Binary output
Control mode > Modulating valve	Settings: – Switching point setting
Compressor start > Compressor ON	Settings: – Local mode selection – Remote mode selection – Clock key – Remote key – Remote contact
Compressor start > Compressor OFF	Settings: – Venting – Holidays
Reset	Settings: – Remote reset selection – Remote key – Remote contact
I/O periphery	Settings: – Binary output function – Show quantities – External messages – Switch – Analog output parameter

Tab. 6      Configuration menu

**4.5.2 Components menu**

Parameters for individual machine components are displayed and set in the components menu option. The menu option comprises the following sub-options (depending on drive motor type):

Navigation (option/sub-option)	Function
Motor > Power switching unit	Display of start mode: <ul style="list-style-type: none"> <li>- Star-delta</li> <li>- Direct start</li> <li>- High tension</li> <li>- SFC contact</li> <li>- Softstart</li> </ul> Settings: <ul style="list-style-type: none"> <li>- Star-delta</li> </ul>
Booster	Settings: <ul style="list-style-type: none"> <li>- Pressure setpoint</li> <li>- Pressure difference</li> </ul>
Air main charging	Settings: <ul style="list-style-type: none"> <li>- Pressure setpoint</li> <li>- Pressure difference</li> </ul>
PD temperature (package discharge temperature)	Settings: <ul style="list-style-type: none"> <li>- Analog transducer input</li> <li>- Switching points for excessive or low package discharge temperature</li> </ul>

Tab. 7 Components menu

**4.5.3 Package test menu**

In the package test menu functions are available for testing the machine. The menu option has the following sub-options:

Navigation (option/sub-option)	Function
TÜV check	Settings: <ul style="list-style-type: none"> <li>- Pressure relief valve test</li> <li>- Temperature sensor test</li> </ul>
Binary inputs	Display: <ul style="list-style-type: none"> <li>- Binary inputs signal state</li> </ul>
Binary outputs	Display: <ul style="list-style-type: none"> <li>- Binary outputs signal state</li> </ul>
Lamps test	Settings: <ul style="list-style-type: none"> <li>- Controller LED test</li> </ul>

Tab. 8 Package test menu



**4.5.4 Communication menu option**

Interface parameters are displayed and set in the communication menu option. The menu option has the following sub-options:

<b>Navigation (option/sub-option)</b>	<b>Function</b>
RS 232	Settings: <ul style="list-style-type: none"><li>– Modem or printer connection</li><li>– Bitrate</li><li>– Transmission format</li></ul>
RS 485	Settings: <ul style="list-style-type: none"><li>– Master-slave-mode</li><li>– Bitrate</li><li>– Transmission format</li><li>– Activating the remote key</li></ul>
Profibus	Display: <ul style="list-style-type: none"><li>– Bus alarm</li></ul> Settings: <ul style="list-style-type: none"><li>– Linking the machine to a master control system (e.g. SAM, central control, PLC, etc.)</li><li>– Slave number</li><li>– Activating the remote key</li></ul>
SMS	Settings: <ul style="list-style-type: none"><li>– Sending short messages (e. g. to KAESER Service on conclusion of a SIGMA TELE CARE-agreement)</li></ul>

Tab. 9 Communication menu

#### 4.6 Outline of the Display Level

Parameters can be displayed and reset, if required, in the Display Level. In the main menu scroll down with the *DOWN* key to sequentially display all Display Level options. Options with lower menu level options can be selected from the main menu.

Navigation (option/sub-option)	Function
Status data > Messages	Display: <ul style="list-style-type: none"> <li>- Event info (message history)</li> <li>- Last alarm</li> <li>- Last warning</li> <li>- Number of current alarm and warning messages</li> <li>- Call-up of all current messages</li> </ul>
Status data > Statistics	Display: <ul style="list-style-type: none"> <li>- Total duty cycle in percent and for SFC RS485 (Machine with frequency converter)</li> <li>- Duty cycle from a certain day and for SFC RS485</li> <li>- Syspress. max</li> <li>- Syspress. min</li> <li>- Internal press. max</li> <li>- Motor starts since a defined day</li> <li>- Motor starts total</li> <li>- Motor starts per day</li> <li>- Motor starts per hour</li> <li>- Motor starts below min. temperature</li> <li>- Last load run</li> <li>- Last idle run</li> <li>- Last motor off</li> </ul> Settings: <ul style="list-style-type: none"> <li>- Resets of duty cycle, motor starts and system pressure from a certain day</li> </ul>
Status data > Printer	Display: <ul style="list-style-type: none"> <li>- All messages that are to be printed</li> </ul> Settings: <ul style="list-style-type: none"> <li>- Printer clock</li> </ul>
analog data	Display: <ul style="list-style-type: none"> <li>- All data that are to be monitored</li> </ul>
Operating data	Display: <ul style="list-style-type: none"> <li>- Compressor, load run, motor, airend, SIGMA CONTROL, modulating valve operating hours</li> <li>- Load valve ON</li> <li>- kWh counter</li> </ul> Settings: <ul style="list-style-type: none"> <li>- kWh counter reset</li> </ul>

Navigation (option/sub-option)	Function
Maintenance	Display: – Time left to the next due maintenance Settings: – Maintenance interval counter – Maintenance interval

Tab. 10 Outline of the Display Level

## 4.7 Operating and Control Modes

### 4.7.1 Machine operating modes

There are three operating modes:

- **LOAD:** the inlet valve is open. The airend delivers compressed air to the system network.  
The drive motor runs under full load.
- **IDLE:** The inlet valve is closed. The minimum pressure/check valve isolates the oil separator tank from the compressed air system. The oil separator is vented down to idling pressure. A residual quantity of air circulates through the bypass hole in the inlet valve, through the airend and back to the inlet valve via the venting valve.  
The drive motor is unloaded and runs at very low power.
- **STANDSTILL:** The inlet valve is closed. The minimum pressure/check valve isolates the oil separator tank from the air system. The oil separator tank is vented.  
The drive motor is stopped.

### 4.7.2 Control modes

In order to maintain system pressure between set minimum and maximum values the controller switches the drive motor back and forth between operating points according to specific rules determined by a selected control mode. This is independent of the volume of compressed air consumed in each case.

One of the various control modes available will provide an optimum duty cycle that matches the individual compressed air demand placed on the machine.

The controller can operate in the following modes:

- DUAL
- VARIO
- QUADRO
- CONTINUOUS

#### **DUAL**

In the DUAL control mode, the drive motor is switched back and forth between full load and idle to keep system pressure between the preset minimum and maximum values. When maximum pressure is reached the drive motor switches to IDLE. When the settable *idle period* has elapsed the motor switches to STANDSTILL.

The shorter the *idle period* setting is made, the sooner (and more frequently) the motor is stopped.

#### **VARIO**

VARIO mode is based on the DUAL control mode. The difference is that the *idle period* is automatically increased or decreased in relation to an increase or decrease in drive motor switching frequency.

#### **QUADRO**

In QUADRO mode the controller switches from LOAD to IDLE during periods of high air demand and directly from LOAD to STANDSTILL during periods of low air demand.

This mode of control requires two pre-set time periods: the *running period* and the *idle/standstill period*. The shorter these time settings, the sooner (and more frequently) the motor stops.

#### **CONTINUOUS**

In CONTINUOUS mode, the drive motor is switched back and forth between full load and idle to keep system pressure between preset minimum and maximum values. When maxi-

imum pressure is reached the drive motor switches to IDLE. The drive motor does not switch to STANDSTILL.

#### **4.7.3 Variable speed drive with frequency converter (SFC)**

In LOAD mode the frequency converter compares ACTUAL system pressure with a system pressure SETPOINT and, depending the difference, adjusts the speed of the drive motor (and therefore the airend) accordingly.

The speed of the airend determines the free air delivery and the working pressure.

If air consumption rises, the frequency converter increases motor speed and therefore increases the volume of air delivered.

If air consumption drops, the converter reduces motor speed and therefore reduces the volume of air delivered.

The network pressure remains constant – within the control range of the converter – regardless of fluctuating air demand.

##### **System pressure exceeds the SETPOINT:**



Outside the frequency converter's range of control the machine reverts to the selected control mode.

##### **DUAL:**

The minimum controllable speed is reached and the machine switches to IDLE mode. The drive motor runs unloaded and consumes very low power.

When the idle period has elapsed the machine switches to STANDSTILL.

##### **VARIO / QUADRO:**

The minimum controllable speed is reached and, depending on the air demand at the time, the machine switches either to IDLE or STANDSTILL.

##### **System pressure falls below the SETPOINT:**

The frequency converter runs the motor up to a speed at which air delivery matches the air demand.

The inlet valve opens and the machine delivers compressed air.

The converter varies the speed of the drive motor according to the air demand. The power consumption of the drive motor rises and falls according to air demand.

#### **4.8 MODULATING Control Mode**

With the help of a mechanical control valve, the proportional controller continuously varies the opening and closing of the inlet valve in relation to the actual air demand. The airend delivers compressed air to the system network.

The load and power consumption of the drive motor rises and falls with the air demand.

To ensure optimal control on large compressors, the control air for the proportional controller is taken from an external air receiver.

## **5 Installation and Operating Conditions**

### **5.1 Installation Site**

See Service Manual for the machine

### **5.2 Installation Conditions**

See Service Manual for the machine

## 6 Installation

### 6.1 Reporting Transport Damage

1. Check the controller for visible and hidden transport damage.
2. Inform the carrier and the manufacturer in writing of any damage without delay.

### 6.2 Machine Identification



If the machine is run in sequenced operation its identification as detailed in the installation diagram is to be taken into account.

#### Identifying the machine for operation in remote mode.

If the machine is operated from a remote control centre:

- ▶ Attach the following notice to warn of remote machine operation.  
**"WARNING: This machine is remotely controlled and can start automatically at any time."**
- ▶ Label the starting device in the remote control centre as follows:  
**"Before starting, make sure that no one is working on the machine and that it can be safely started."**

#### Identifying the machine for clock control mode operation



Attach the following notice to warn of clock controlled machine operation.  
**"WARNING: This machine is clock-controlled and can start at any time."**

## **7 Initial Start–up**

### **Outline**

SIGMA CONTROL was designed and developed for a number of practical applications. Potential settings are correspondingly varied.

It is possible that only a few of these settings are needed for the initial start–up. This depends on the application.

The following sections explain the large number of practical applications, but only one configuration is relevant for a specific use.

- 7.1: Configuring the controller (display format, units, languages, etc.)
- 7.2: Matching the pressure parameters of the machine and possible modules
- 7.3: Configuring machine start and stop
- 7.4: Setting the control mode
- 7.5: Configuring local operating modes
- 7.6: Configuring sequencing modes (Profibus, master-slave, remote contact, etc.)
- 7.7: Configuring output to a PC or modem (serial interface)
- 7.8: Configuring SMS messages (e.g. for a SIGMA TELE-CARE contract)
- 7.9: Configuring input and output signals
- 7.10: Configuring the machine's discharge air temperature
- 7.11: Activating remote reset
- 7.12: Linking to an external pressure transducer
- 7.13: Setting up the timer for condensate drainage
- 7.14: Activating energy–saving mode for the refrigeration dryer
- 7.15: Initial start–up



## 7.1 Configuring the Controller



All controller settings are explained in detail in the following sections. For experienced users, the most common settings are listed in the "Quick User Guide".

This chapter explains the following:

7.1.1: Selecting menu options (introduction)

7.1.2: Changing display language

7.1.3: Entering and displaying passwords

7.1.4: Setting up time and date

7.1.5: Setting up display format (date, time, units of pressure and temperature)

7.1.6: Activating summer/winter time

7.1.7: Activating/deactivating the *IDLE* mode

### 7.1.1 Selecting menu options



The keys and LED indications are shown in the fold-out to this service manual.

All menu options can be selected with the *DOWN*, *UP* and *Enter* keys.

The menu options are arranged in two levels:

#### **For example: to select menu option Configuration > General**

1. Move from the main menu to the Display and Set-up Level with the *UP* key.
2. Keep on pressing the *UP* key until *configuration* appears in the third line of the display.
3. Press the *Enter* key to open the configuration menu.  
The options in the configuration menu can be selected with the *DOWN* or *UP* keys, for example *general* or *pressure settings*.
4. Keep on pressing the *UP* key until *general* appears in the third line of the display.
5. Press the *Enter* key.  
The actual menu is the *general* menu option in the configuration menu. Using the *DOWN* or *UP* keys the menu options in the *general* menu, for example *version no.* or *weekday*, can now be selected.

### 7.1.2 Changing display language

1. Keep pressing the *UP* key until the selected language appears.
2. Press the *Enter* key.
3. Keep on pressing the *DOWN* key or the *UP* key until the required language appears.
4. Press the *Enter* key to accept the language.
5. Press the *Escape* key as often as necessary to return to the main menu.

### 7.1.3 Entering and displaying passwords

The following passwords have been entered in the controller at the factory:

- Password for Level 0: **00000**
- Password for Level 4: **12EXP**

1. Keep pressing the *UP* key until `password` appears.
2. Press the *Enter* key.

```
88psi 180°F
Password
XXXXX L0 <
XXXXX L0
```

*actual level*

3. Press the *Enter* key.  
The cursor appears in inverse over the first character of the password `XXXXX`.
4. Keep on pressing the *DOWN* key or the *UP* key until the required character appears.
5. Press the *Enter* key.  
The cursor jumps to the next character of the password.
6. Set the remaining characters of the password until it is complete.  
After entering the last character the activated password level is displayed.
7. Press the *Escape* key as often as necessary to return to the main menu.

#### Displaying the actual password

1. In the main menu, keep on pressing the *UP* key until `password` appears in the third line of the display.
2. Press the *Enter* key.

```
88psi 180°F
Password
XXXXX L 4 <
XXXXX L 4
```

*display of actual level*

3. Press the *DOWN* key.
4. Press the *Enter* key.  
The actual password is displayed.

#### Changing the actual password



The password entered at the factory can be changed here. However, this is not recommended.

5. Press the *Escape* key as often as necessary to return to the main menu.

#### 7.1.4 Setting up time and date

Condition: password level 4 is activated,  
menu option `configuration > general` is selected (see 7.1.1).

#### Checking and setting time



If the machine is being operated with a time program (in clock mode) check the time at regular intervals for discrepancies (generally once per year).

1. Keep on pressing the *DOWN* key until the actual time appears in the third line of the display.

```

88psi 180°F
-> 23.07.2004
-> 16:10:31 < actual time
. . .

```

2. Press the *Enter* key.  
The cursor appears in inverse over the first numeral (hours)
3. Change the time with the *DOWN* or *UP* key.
4. Save the hours with the *Enter* key.
5. Repeat for the minutes and seconds.
6. Press the *Escape* key as often as necessary to return to the main menu.

#### Setting the date

Condition: password level 4 is activated,  
menu option configuration > general is selected (see 7.1.1).

1. Keep on pressing the *DOWN* key until the actual date appears in the third line of the display.

```

88psi 180°F
Friday actual weekday.
-> 22.07.2004 < actual date
-> 10:25:54 actual time

```

2. Press the *Enter* key.  
The cursor appears in inverse over the first numeral 22.07.04
3. Change the date with the *DOWN* or *UP* key.
4. Save the date with the *Enter* key.
5. Repeat for the month and year.
6. Press the *Escape* key as often as necessary to return to the main menu.

### 7.1.5 Setting display formats

#### Setting the date format

The date can be shown in the following formats:

Format	Example:
DD:MM:YY	30.08.04
YY-MM-DD	04-08-30
MM/DD/YY	08/30/04

Tab. 11 Date format

Condition: password level 4 is activated,  
menu option configuration > general is selected  
(see 7.1.1).

1. Press the *DOWN* key until date format appears.

```

88psi 180°F
Date format
-> DD.MM.YY < actual date format
. . .

```

2. Press the *Enter* key to change the format.  
A cursor appears in inverse over the last character -> DD.MM.YY
3. Change the format with the *DOWN* or *UP* key.
4. Save the format with the *Enter* key.
5. Press the *Escape* key as often as necessary to return to the main menu.

### Setting the time format

The time can be shown in the following formats:

Format	Example:
hh:mm:ss	13:33:45
hh:mm	13:33
hh:mm:ssAM/PM	01:33:45PM
hh:mm AM/PM	01:33PM

Tab. 12 time formats

Condition: password level 4 is activated,  
menu option configuration > general is selected  
(see 7.1.1).

1. Press the *DOWN* key until time format appears.

```

88psi 180°F
time format
-> hh:mm:ss < actual time format
. . .

```

2. Press the *Enter* key to change the format.  
A cursor appears in inverse over the last character -> hh.mm.ss.
3. Change the display format with the *DOWN* or *UP* key.
4. Save the display format with the *Enter* key.
5. Press the *Escape* key as often as necessary to return to the main menu.

**Setting the unit of pressure**

Pressure can be displayed in the following units:

Format	Example:
bar	5.5 bar
hPa (Hectopascal)	5523 hPa
MPa (Megapascal)	0.55 MPa
psi (pressure per square inch)	80 psi
at (atmospheric pressure)	5.6 at
"Hg (inches mercury)	162.9 "Hg

Tab. 13 Units of pressure

Condition: password level 4 is activated,  
menu option configuration > general is selected  
(see 7.1.1).

1. Press the *DOWN* key until unit of pressure appears.

```

88psi 180°F
Unit of pressure
-> psi < actual unit of pressure
. . .

```

2. Press the *Enter* key to change the unit.  
A cursor appears in inverse over the last character -> psi.
3. Change the unit with the *DOWN* or *UP* key.
4. Save the selected unit with the *Enter* key.
5. Press the *Escape* key as often as necessary to return to the main menu.

**Setting the unit of temperature**

Temperature can be displayed in the following units:

Format	Example:
°C (degrees Celsius)	46 °C
K (Kelvin)	319 K
°F (degrees Fahrenheit)	45.56 °C

Tab. 14 Units of temperature

Condition: password level 4 is activated,  
menu option configuration > general is selected  
(see 7.1.1).

1. Press the *DOWN* key until unit of temperature appears.

```

88psi 180°F
unit of temp.
-> °C < actual unit of temperature
. . .

```

2. Press the *Enter* key to change the unit.  
A cursor appears in inverse over the last character -> °C.
3. Change the unit with the *DOWN* or *UP* key.
4. Save the selected unit with the *Enter* key.
5. Press the *Escape* key as often as necessary to return to the main menu.

### 7.1.6 Setting and activating Summer/Winter time

The controller can automatically changeover summer and winter time. To do this it is necessary, in certain cases, to

- set the changeover time for the start of summer and winter times
- activate automatic changeover.

#### Setting the changeover time for summer/winter time

Condition: password level 4 is activated,  
menu option configuration > general is selected  
(see 7.1.1).

1. Keep on pressing the *DOWN* key until `summer/winter t` appears in the third line of the display.
2. Press the *Enter* key.

The changeover times for the start of summer time are shown one after the other:

```
88psi 180°F
summertime
-> March      month of changeover
-> last       day of changeover
```

3. Press the *DOWN* key once to display further settings:
  - month of changeover [January - December]
  - day of changeover in the month [1.,2.,3., last but one, last (day of the month)]
  - weekday changeover [Monday - Sunday]
  - changeover time [0:00 hours - 23:59 hours]

The changeover times for winter are shown in the same order.



Note the required times of changeover on a piece of paper before changing any settings.

4. Scroll to the required changeover time with the *DOWN* or *UP* keys.
5. Press the *Enter* key to select the required changeover time.
6. Change the settings with the *DOWN* or *UP* key.
7. Save the changeover time with the *Enter* key.

#### Activating summer/winter time

8. Keep pressing the *DOWN* key until the `act. : n` is displayed:
9. Press the *Enter* key.

A cursor appears in inverse over n in `active: n`.

10. Press the *UP* key.

The display changes from "n" to "y".

```
88psi 180°F
...
act.: y <
```

11. Confirm automatic changeover with the *Enter* key.
12. Press the *Escape* key as often as necessary to return to the main menu.

### 7.1.7 Activating/deactivating the IDLE mode

The *IDLE* mode key on the control panel can be deactivated to prevent unauthorized use.

Condition: password level 4 is activated,  
menu option configuration is selected (see 7.1.1).

1. Keep pressing the *UP* or *DOWN* key until `pressure settings` appears in the third line of the display.
2. Press the *Enter* key.
3. Keep pressing the *UP* or *DOWN* key until `load control` appears in the third line of the display.
4. Press the *Enter* key.
5. Keep pressing the *DOWN* key until `settings` appears in the third line of the display.
6. Keep pressing the *DOWN* key until `idle key: y` appears in the third line of the display.
7. Press the *Enter* key.  
The cursor appears in inverse over the `y` (active).
8. Use the *DOWN* key or the *UP* key to set as required and confirm by pressing *Enter*.
9. Press the *Escape* key as often as necessary to return to the main menu.

## 7.2 Configuring the pressure settings

This chapter contains information on the display and configuration of all the machine pressure parameters and is divided into the following sections:

7.2.1: List of pressure parameters (compressors, vacuum pumps, components)

7.2.2: Displaying pressure parameters

7.2.3: Configuring pressure parameters for compressors

7.2.4: Configuring pressure parameters for vacuum pumps

7.2.5: Configuring pressure parameters for boosters and air main charging compressors

**7.2.1 List of pressure parameters**

Different parameters are set depending on whether the machine is operated as a rotary screw compressor or rotary screw vacuum pump. The machine is configured with the following parameters:

<b>Compressors</b>	<b>Explanation</b>
pRV (pressure relief valve)	Display: Relief valve: pRV: activating pressure of the pressure relief valve on the oil separator tank
Nominal pressure	Display: Nominal press.:The compressor is designed for this pressure (maximum system pressure setpoint)
System pressure set-point	The system pressure setpoint can be controlled by two different values p1 and p2 Settings: <ul style="list-style-type: none"> <li>– p1 SP: switching point p1, SD: switching differential p1</li> <li>– p2 SP: switching point p2, SD: switching differential p2</li> </ul>
Pressure increase pE	Settings: <ul style="list-style-type: none"> <li>– pE SP: switching point pE; upper safety limit for maximum machine pressure; in external LOAD control this parameter serves to switch from LOAD to IDLE mode in case of a fault.</li> <li>– pE SD: pE switching differential</li> <li>– dp FC: the limit for machines with variable frequency speed control (SFC); limit of lowest air delivery, when this value is exceeded [maximum system pressure setpoint SP+ dpFC] the compressor is switched from LOAD to IDLE mode.</li> </ul>
System pressure low	When the "sys.press. low" limit is reached a warning message is displayed. Settings: <ul style="list-style-type: none"> <li>– SD: differential pressure for low system pressure, SP: switching point for low system pressure</li> <li>– A warning message is optional: no message, warning message on the display or an output signal, e.g. to the remote control centre.</li> </ul>
Minimum cut-in pressure	Display: cut-in press min For design reasons, pressure can only be built up above this value.

Tab. 15 Pressure parameters of the compressors



Vacuum pumps	Explanation
System pressure high	<p>Minimum system pressure When the "sys.press. high" limit is reached a warning message can be displayed.</p> <p>Settings:</p> <ul style="list-style-type: none"> <li>– SD: differential pressure for high system pressure, SP: switching point for high system pressure</li> <li>– A warning message is optional: no message, warning message on the display or an output signal, e.g. to the remote control centre.</li> </ul>
System pressure set-point	<p>The system pressure setpoint can be controlled by two separate parameters p1 and p2:</p> <p>Settings:</p> <ul style="list-style-type: none"> <li>– p1 SP: switching point p1, SD: switching differential p1</li> <li>– p2 SP: switching point p2, SD: switching differential p2</li> </ul>
Pressure fall pA	<p>Settings:</p> <ul style="list-style-type: none"> <li>– pA SP: switching point pA; Lower safety limit for minimum machine pressure; in external LOAD mode the parameter pA serves to change from IDLE to LOAD mode if there is a fault.</li> <li>pA SD: Switching differential pA</li> </ul>

Tab. 16 Pressure parameters for rotary screw vacuum pumps

Components	Explanation (displayed text, settings)
Booster	<p>Reminder: take the inlet pressure of the booster into account</p> <p>Settings:</p> <ul style="list-style-type: none"> <li>– pN SP: booster ON switching point</li> <li>pN SD: booster ON switching differential</li> </ul> <p>In addition:</p> <ul style="list-style-type: none"> <li>– output for the control signal to the booster</li> </ul>
Air main charging	<p>When the air main is discharged a valve can be fitted downstream of the machine that only opens when the value pN SP is reached.</p> <p>Settings:</p> <ul style="list-style-type: none"> <li>– pN SP: air main charging switching point,</li> <li>pN SD: air main charging switching differential</li> </ul> <p>In addition:</p> <ul style="list-style-type: none"> <li>– output for the control signal to the air main charging valve</li> </ul> <p>Note:</p> <p>Contact KAESER Service for advice.</p>

Tab. 17 Pressure parameters for the components

### 7.2.2 Displaying pressure parameters

Condition: password level 4 is activated.

1. In the main menu, keep pressing the *UP* key until `configuration` appears in the third line of the display.

2. Press the *Enter* key.  
pressure settings appears in the display.
3. Press the *Enter* key.

88psi 180°F	
Pressure sensors	
compressor <	<i>menu option for compressors</i>
Vacuum package	<i>menu option for vacuum pumps</i>

**Displaying compressor parameters**

1. Press the *Enter* key.

88psi 180°F	
Setpoint press.	
p1 SP: 80psi <	<i>actual p1 pressure setpoint</i>
SD: -7.0psi	<i>actual p1 switching difference</i>

2. Display further parameters with the *UP* and *DOWN* keys.

**Displaying vacuum pump parameters**

1. Using the *DOWN* key, select vacuum package in the pressure settings menu option.
2. Press the *Enter* key.

88psi 180°F	
. . .	
SD: -7.0psi <	<i>actual p1 switching difference</i>
p1 SP: 80psi	<i>actual p1 pressure setpoint</i>

3. Display further parameters with the *UP* and *DOWN* keys.

**7.2.3 Configuring the pressure parameters for compressors**

**7.2.3.1 Configuring system pressure setpoints p1 and p2 for the compressor**

The pressure parameters can only be set within certain limits:

$$\text{Nominal machine pressure} \geq \text{system pressure setpoint SP} \geq \text{Min. cut-in pressure (cut-in press min) + switching differential SD}$$

If system pressure SP falls below SP – SD the machine switches to LOAD mode. When the system pressure setpoint SP is reached the machine switches to IDLE mode.

Condition: password level 4 is activated.

1. Select menu options configuration > pressure settings > compressor (see section 7.2.2)
2. Press the *Enter* key to configure the system pressure setpoint for p1.
3. Set the value with the *UP* key or the *DOWN* key.
4. Press the *Enter* key to accept the value.

5. Configure the switching difference p1 SD in the same way.
6. If necessary, configure the value for p2 in the same way.
7. Press the *Escape* key as often as necessary to return to the main menu.

### 7.2.3.2 Configuring low system pressure

A message warning of low pressure is displayed when the value set for low system pressure is reached.

The configuration of the output for the warning message is described in 7.9.1.

Condition: password level 4 is activated.

1. Select menu options configuration > pressure settings > compressor (see section 7.2.2).
2. Keep pressing the *DOWN* key until the following is displayed:

```

88psi 180°F
System pressure
low
SD: 7.0psi < actual switching differential
SP: 60psi actual low system pressure

```

3. Press the *Enter* key to configure the switching difference
4. Set the value with the *UP* key or the *DOWN* key.
5. Press the *Enter* key to accept the value.
6. Configure the system pressure low SP in the same way.
7. Press the *Escape* key as often as necessary to return to the main menu.

### 7.2.3.3 Configuring pressure increase pE

Pressure increase pE serves as a safety limit when the machine is externally controlled. When pressure reaches value pE (for example, when the external control functions incorrectly) the machine is switched into IDLE mode.

The warning message `ext.load signal?` is displayed.

Condition: password level 4 is activated.

1. Select menu options configuration > pressure settings > compressor (see section 7.2.2)
2. Keep pressing the *DOWN* key until the following is displayed:

```

88psi 180°F
press. increase
pE SP: 103psi< actual pressure increase
SD: -9.0psi actual pressure increase switching differential

```

3. Press the *Enter* key to configure the pressure increase
4. Set the value with the *UP* key or the *DOWN* key.
5. Press the *Enter* key to accept the value.
6. If required, set the switching differential SD and dpFC in the same way.
7. Press the *Escape* key as often as necessary to return to the main menu.

## 7.2.4 Configuring the pressure parameters for vacuum pumps

### 7.2.4.1 Adjusting system pressure setpoint for the vacuum pump

The pressure parameters can only be set within certain limits:

$$\text{system pressure setpoint SP} \leq \text{System pressure high}$$

If system pressure rises above  $SP + SD$  the machine switches to LOAD mode. When the system pressure setpoint  $SP$  is reached the machine switches to IDLE mode.

Condition: password level 4 is activated.

1. Select menu option configuration > pressure settings > vacuum package (see section 7.2.2).
2. Press the *Enter* key to configure the system pressure setpoint for p1.
3. Set the value with the *UP* key or the *DOWN* key.
4. Press the *Enter* key to accept the value.
5. Configure the switching difference p1 SD in the same way.
6. If necessary, configure the value for p2 in the same way.
7. Press the *Escape* key as often as necessary to return to the main menu.

### 7.2.4.2 Configuring high vacuum pump system pressure

A message warning of high pressure is displayed when the value set for high system pressure is reached.

The configuration of the output for the warning message is described in section 7.9.1.

Condition: password level 4 is activated

1. Select menu option configuration > pressure settings > vacuum package (see section 7.2.2).
2. Keep pressing the *UP* key until the following is displayed:

89hpa	180°F	
System pressure		
high		
SP:	100hpa <	<i>actual system pressure high</i>
SD:	100hpa	<i>actual switching differential</i>

3. Press the *Enter* key to configure the switching point SP
4. Set the value with the *UP* key or the *DOWN* key.
5. Press the *Enter* key to accept the value.
6. Configure the switching differential SD in the same way.
7. Press the *Escape* key as often as necessary to return to the main menu.

### 7.2.4.3 Configuring pressure fall pA for the vacuum package

Pressure fall pA serves as a safety limit when the machine is externally controlled. When the pressure reaches the value pA (for example, when the external control functions incorrectly) the machine is switched into IDLE mode.

The warning message `ext.load signal?` is displayed.

Condition: password level 4 is activated.

1. Select menu option configuration > pressure settings > vacuum package (see section 7.2.2)
2. Keep pressing the *DOWN* key until the following is displayed:

89hpa 180°F	
pressure fall	
SD: 20hpa <	<i>actual switching differential for pressure fall</i>
pA SP: 20hpa	<i>actual switching point for pressure fall</i>

3. Press the *Enter* key to configure the switching point SP for pressure fall
4. Set the value with the *UP* key or the *DOWN* key.
5. Press the *Enter* key to accept the value.
6. Configure the switching differential SD in the same way.
7. Press the *Escape* key as often as necessary to return to the main menu.

### 7.2.5 Configuring pressure parameters for boosters and air main charging compressors

Depending on the type of compressor, pressure parameters for peripheral components can be configured. The settings for peripheral components are made in the menu option `components`.

Condition: password level 4 is activated.

1. In the main menu, keep pressing the *UP* key until `components` appears in the third line of the display.
2. Press the *Enter* key.

88psi 180°F	
motor <	<i>menu option for drive motor settings</i>
Booster	<i>menu option for the booster settings</i>

3. Further menu options can be selected with the *DOWN* key.

88psi 180°F	
Booster	<i>menu option for the booster settings</i>
AM charging <	<i>menu option for air main charging settings</i>
PD temperature	<i>menu option for package discharge temperature settings</i>

#### 7.2.5.1 Configuring booster pressure parameters

Boosters may only be started when a defined inlet pressure has been built up. The controller provides an output signal that enables a booster start. The switching point and switching differential for the output signal are set as follows:

Condition: password level 4 is activated.

1. In the main menu select components > booster (see section 7.2.5).

```

88psi 180°F
booster ON
pN SP: 94psi < actual switching point for booster ON
SD: -30psi actual switching differential
    
```

2. Press the *Enter* key to configure the switching point SP
3. Set the value with the *UP* key or the *DOWN* key.
4. Press the *Enter* key to accept the value.
5. Configure the switching differential SD in the same way.
6. Press the *Escape* key as often as necessary to return to the main menu.

### 7.2.5.2 Configuring the pressure parameters for air main charging

An air main charging system is only used for rotary screw compressors. The controller provides an output signal for an air main charging valve upstream of the air main. The switching point and switching differential for the output signal to the valve are set as follows:



Contact KAESER Service for advice.

Condition: password level 4 is activated

1. In the main menu select components > booster (see section 7.2.5).

```

88psi 180°F
valve open
pN SP: 65psi < actual switching point for air main charging
SD: -7.0psi actual switching differential
    
```

2. Press the *Enter* key to configure the switching point SP
3. Set the value with the *UP* key or the *DOWN* key.
4. Press the *Enter* key to accept the value.
5. Configure the switching differential SD in the same way.
6. Press the *Escape* key as often as necessary to return to the main menu.

## 7.3 Configuring machine start and stop

The following settings can be made to start the machine:

Function	Status on delivery/setting	See
Manual start with the ON key	always possible	–
Automatic start/stop in programmed clock mode	no clock (time) program entered	7.3.1
Holidays	not set	7.3.2

Remote start, e.g. from a control centre	deactivated	7.3.3
IDLE phase (venting function)	deactivated	7.3.4
Automatic restart after power failure (after delay period)	activated	7.3.5
Minimum airend starting temperature	set to 40 ° F	–
Drive motor start mode (depending on type)	set	7.3.6

### 7.3.1 Automatic start/stop in programmed clock mode

#### Overview

- If not activated, enter password for level 4
- Select the clock menu option
- Activating the *clock* key
- Set up the clock program if this has not already been done

#### 7.3.1.1 Select the clock menu option

Condition: password level 4 is activated.

1. In the main menu, keep pressing the *UP* key until *clock* appears in the third line of the display.
2. Press the *Enter* key.

```

88psi 180°F
clock key:  n
      reset: n
<
- - - - -

```

#### 7.3.1.2 Activating the *clock* key

1. Press the *UP* key once.

```

88psi 180°F

clock key:  n<
      reset: n

```

2. Press the *Enter* key.  
An inverse cursor appears in the third line.
3. Press the *UP* key once.  
The display changes to *clock key y*.
4. Press the *Enter* key.  
The *clock* key is activated.
5. Press the *clock* key to enable clock mode.

**7.3.1.3 Setting the clock program (example)**



When a clock program is first set up, note the ON and OFF times on a sheet of paper first.

As well as individual weekdays, the following cycles are also available: Mon - Thu, Mon - Fri, Mon- Sat, Mon - Sun, Sat - Thu.

As well as these fixed cycles, an OFF period (holidays) can also be programmed (see section 7.3.2).

**Example:**

- Machine ON: weekdays 06:30 - 17:00, Fridays 06:30 - 15:00;
- Machine OFF: Sat - Sun and during midday break from 12:00 - 13:00

The following switching points result:

No.	Day	Time	Action
1	Mon - Fri	06:30	ON
2	Mon - Fri	12:00	OFF
3	Mon - Fri	13:00	ON
4	Mon - Thu	17:00	OFF
5	Fri	15:00	OFF

*Tab. 18 Example of a machine ON/OFF clock program*

Condition: password level 4 is activated,  
the *clock* key is activated,  
the clock menu option is selected.

1. Keep pressing the *DOWN* key until the following is displayed:

```

88psi 180°F
- - - - -
01: n.a. < switching point 01: not active
- - - - -
    
```

2. Press the *Enter* key.
3. Press the *UP* key until 01 Mon-Fri appears and confirm with the *Enter* key.
4. Press the *DOWN* key.
5. Press the *Enter* key to configure the ON time.

```

88psi 180°F
01 Mon-Fri
 00:00 < first ON switching point hh:mm
compr. OFF
    
```

6. First set 6 hours and then 30 minutes with the *DOWN* or *UP* keys, confirming each entry with the *Enter* key.
7. Press the *DOWN* key.



- Press the *Enter* key.

```

88psi 180°F
06:30      switching point setting
comp. OFF < actual action
- - - - -

```

- Press the *UP* key and, using the *Enter* key, select `comp. ON`.  
The first ON cycle from Mon - Fri has been programmed.
- Set up the remaining switching points in the same way.
- Press the *Escape* key as often as necessary to return to the main menu.
- Press the *clock* key to enable clock mode.

### 7.3.2 Setting up the holiday period

As well as the fixed cycles of a clock program or a timer a longer standstill period can be set for, for example, company holidays.

#### Overview

- If not activated, enter password for level 4
- Selecting menu options configuration > compressorstart> compressor OFF
- Activate holidays
- Set up the holiday period, if this has not already been done

#### Selecting menu options configuration > compressorstart> compressor OFF

Condition: password level 4 is activated,  
menu option configuration is selected.

- In the main menu, keep pressing the *UP* key until `configuration` appears in the third line of the display.
- Press the *Enter* key.
- Keep pressing the *DOWN* key until `compressor start` appears in the third line of the display.
- Press the *Enter* key.

```

88psi 180°F

compressor ON <
Compressor OFF

```

- Press the *DOWN* key.
- Press the *Enter* key to select menu option `compressor OFF`

#### Activating/deactivating the holidays function

- Keep pressing the *DOWN* key until `holidays: n` appears in the third line of the display.
- Press the *Enter* key.  
The cursor appears inverse over `n`

9. Press the *UP* key.

The display changes to `holidays y`.

10. Confirm the setting with the *Enter* key.

The holidays function is activated and can be used.

The holidays function can be deactivated in the same way.

11. Configure the holiday period if this has not already been done

#### **Setting the holiday period**

12. Press the *DOWN* key.

The set date and time of the holiday period appears in the display.

88psi 180°F holidays: y -> 01.01. < 00:00	<i>the holiday period is activated</i> <i>actual date: start of holiday dd.yy</i> <i>actual time: start of holiday hh:mm</i>
--	--

13. Press the *Enter* key.

A cursor appears inverse over the first digit of the date.

14. Use the *DOWN* key or the *UP* key to set the required day, then the month and confirm each setting by pressing *Enter*.

15. Press the *DOWN* key to change to the time setting and configure the remaining switching points in the same way.

16. Press the *Escape* key as often as necessary to return to the main menu.

### **7.3.3 Starting the machine remotely from a control centre (remote ON/OFF)**

If the machine is to be started and stopped from a remote control centre then the following settings have to be made:

#### **Overview**

- Make the electrical connection (a spare input for the remote contact is to be found in the electrical wiring diagram for the machine, DI 1.0 being preferred).
- Switch machine start to remote mode
- Activating the *remote* key
- If required, activate the *clock* key and configure the clock program (see section 7.3.1.3)
- If necessary, assign the remote contact to another input
- Press the *remote* key

#### **7.3.3.1 Switch the machine to remote mode**

Two methods are available to start the machine remotely from a control centre:

- Method A: starting the compressor with the input signal from the remote control centre.
- Method B: starting the compressor from the remote control centre in addition to the configured ON/OFF clock program.  
The machine can be started from the remote control centre even though the clock key is activated and the program has selected compressor OFF at this point in time.

Condition: an electrical connection has been made,  
password level 4 is activated,  
menu option configuration is selected.

1. Keep pressing the *DOWN* key until *compressor start* appears in the third line of the display.
2. Press the *Enter* key.

```
88psi 180°F
compressor ON <
Compressor OFF
```

3. Press the *Enter* key again.
4. Keep pressing the *DOWN* key until the following is displayed:

```
88psi 180°F
remote mode
-> key < actual setting (example)
remote key: n remote key not activated
```

5. Press the *Enter* key.
6. For method A, keep pressing the *DOWN* key until *->key+RC* appears.  
or  
For method B, keep pressing the *DOWN* key until *->key+clock-RC* appears.
7. Save the setting with the *Enter* key.

### 7.3.3.2 Activating/deactivating the *remote* key

8. Press the *DOWN* key once.

```
88psi 180°F
->key+RC compressor start via the remote contact activated
remote key: n< remote key (not activated)
clock key: n clock key (not activated)
```

9. Press the *Enter* key.  
The cursor appears inverse over the *n* (*remote* key not activated).

10. Press the *UP* key.  
The display changes to *remote key y*.

11. Confirm the setting with the *Enter* key.  
The *remote* key function is activated and can be used.

The *remote* key can be deactivated in the same way.

12. If the method with the clock program is selected, the *clock* key must be activated in the same way.

### 7.3.3.3 Assigning another input

13. Keep pressing the *DOWN* key until the following is displayed:

```
88psi 180°F
* comp. ON
RC ->DI1.0 < remote contact DI 1.0 (preset)
```

14. Press the *Enter* key.

The cursor appears inverse over 1.0.

15. Use the *DOWN* key to select another input and confirm with the *Enter* key.

The input has now been assigned.

16. Press the *remote* key to enable the machine to be started from the remote control centre.

### 7.3.4 Activating/deactivating the IDLE phase (venting function)

After receiving an OFF signal from the remote control centre an additional IDLE (venting) phase can be activated before the machine is stopped completely. The duration of the IDLE phase is regulated by the internal pressure.

Condition: password level 4 is activated,  
menu option compressor OFF is selected (see 7.3.2).

1. Press the *DOWN* key.

2. Press the *Enter* key to select menu option compressor OFF

```
88psi 180°F
* comp. OFF
venting: n< actual setting: venting deactivated
. . .
```

3. Press the *Enter* key again.

The cursor appears inverse over n

4. Press the *UP* key.

The display changes to venting: y.

5. Confirm the setting with the *Enter* key.

The venting function is activated.

The venting function can be deactivated in the same way.

### 7.3.5 Activating/deactivating and setting up automatic restart after a power failure

Automatic restart after a power failure function is normally activated.

To avoid overloading the mains power supply through several machines starting simultaneously a delay period determining the restart of each machine can be entered.

#### Overview

- If not activated, enter password for level 4
- Select menu options configuration > compressorstart> compressor ON
- Activate/deactivate the automatic restart function  
or  
Set up the restart delay period

Condition: password level 4 is activated,  
menu option configuration is selected.

1. In the main menu, keep pressing the *DOWN* key until `compressorstart` appears in the third line of the display.
2. Press the *Enter* key.

```
88psi 180°F  
  
Compressor ON  
Compressor OFF
```

### Deactivating/activating automatic restart

3. Keep pressing the *DOWN* key until the following is displayed:

```
88psi 180°F  
.  
.  
.  
restart: y automatic restart activated  
10.0 s | 0.0 s entered | expiring delay period
```

4. Press the *Enter* key.  
A cursor appears inverse over the y.
5. Press the *DOWN* key.  
The display changes to n.
6. Press the *Enter* key to accept the setting.  
Automatic restart after a power failure is now deactivated.

The function can be activated in the same way.

7. Press the *Escape* key as often as necessary to return to the main menu.

### Setting up the automatic restart delay period

Condition: password level 4 is activated,  
menu option configuration is selected (see above).



If several machines are in operation, set them up for a staggered start.

- Orientate the automatic restart delay period to the IDLE to LOAD periods set on the other machines.

1. Keep pressing the *DOWN* key until the following is displayed:

```
88psi 180°F  
restart: y automatic restart is activated  
10.0s | 0.00s < entered | expiring delay period  
.  
.  
.
```

2. Press the *Enter* key.
3. Use the *DOWN* key or *UP* key to set the delay period and confirm with the *Enter* key.
4. Press the *Escape* key as often as necessary to return to the main menu.

### 7.3.6 Setting up the delays for star-delta-start

If the machine is started in star-delta configuration, adjustments to the changeover delays can be made in the menu option components > motor.

Condition: password level 4 is activated

1. In the main menu, keep pressing the *UP* key until *components* appears in the third line of the display.
2. Press the *Enter* key.

```
88psi 180°F
motor < menu option for drive motor settings
Booster
```

3. Press the *Enter* key to select menu option *motor*.  
The menu option *power switching* appears.
4. Press the *Enter* key again.  
The motor start configuration appears.
5. Keep pressing the *DOWN* key until *settings* appears.
6. The changeover delays for the star-delta start can be set up in this menu option.
7. Press the *Escape* key as often as necessary to return to the main menu.

## 7.4 Activating and setting up the control modes

The controller is provided with various control modes that can bring about different capacity utilisation depending on machine application. A list of control modes is given in chapter 4.7.2.

### 7.4.1 Selecting control modes DUAL/QUADRO/VARIO/CONTINUOUS

Condition: password level 4 is activated

1. In the main menu, keep pressing the *UP* key until *configuration* appears in the third line of the display.
2. Press the *Enter* key.
3. Keep pressing the *DOWN* key until *control mode* appears in the third line of the display.
4. Press the *Enter* key.

```
88psi 180°F
local mode Operating mode
-> Dual < actual control mode
Control mode
```

5. Press the *Enter* key again.  
A cursor appears inverse over the actual control mode.
6. Use the *UP* key or the *DOWN* key to select the required control mode and confirm by pressing *Enter*.
7. Press the *Escape* key as often as necessary to return to the main menu.

### 7.4.2 Setting up the IDLE period in DUAL control

When the idling period has elapsed, the machine comes to a STANDSTILL. The shorter the period, the more often the machine will switch from IDLE to STANDSTILL. In this respect the maximum motor starting frequency must also be taken into account.



Take the motor starting frequency into consideration:

- ▶ Keep to the upper and lower limits of the idle period.

Condition: password level 4 is activated  
menu option configuration > control mode is selected  
(see section 7.4.1)

1. Keep pressing the *DOWN* key until the following display appears in the *settings* option.

```
88psi 180°F
- - - - -
* Dual <
* Quadro
```

2. Press the *Enter* key to select menu option *Dual*.  
The actual IDLE period appears.
3. Press the *Enter* key again.  
A cursor appears over the IDLE period.
4. Set the required IDLE period with the *UP* or *DOWN* keys.
5. Press the *Enter* key again to accept the value.
6. Press the *Escape* key as often as necessary to return to the main menu.

### 7.4.3 Setting the unloaded and minimum running period in QUADRO control mode

When the minimum running period has elapsed, the machine switches from IDLE to STANDSTILL. Depending on the setting for the unloaded period, the machine goes from LOAD to IDLE or comes directly to a STANDSTILL.



Take the motor starting frequency into consideration:

- ▶ Pay attention to the upper and lower limits for the idle period.

Condition: password level 4 is activated  
menu option configuration > control mode is selected  
(see section 7.4.1)

1. Keep pressing the *DOWN* key until the following display appears in the *settings* option.

```
88psi 180°F
* Dual
* Quadro <
. . .
```

2. Press the *Enter* key to select menu option Quadro.

```
88psi 180°F
Min run period
400s | 400s < actual minimum running period
Unloaded period
```

3. Press the *Enter* key again.  
A cursor appears inverse over the running period.
4. Set the required minimum running period with the *UP* or *DOWN* keys.
5. Press the *Enter* key again to accept the value.
6. Set up the unloaded period in the same way.
7. Press the *Escape* key as often as necessary to return to the main menu.

#### 7.4.4 Setting up the control pressure valve for MODULATING control mode

In MODULATING control the inlet valve is continuously opened and closed according to the air demand with the help of a control valve (proportional controller). Depending on system pressure, a solenoid valve switches between internal and external control pressure. The switching point and switching differential of the control pressure valve can be set in the controller.

Condition: password level 4 is activated  
menu option configuration > control mode is selected  
(see section 7.4.1)

1. Keep pressing the *DOWN* key until mod. valve appears in the third line of the display.
2. Press the *Enter* key.

```
88psi 180°F
mod. valve
SD: -7.0psi < switching differential
pN SP: 80psi switching point of the control pressure valve
```

3. Press the *Enter* key again.  
A cursor appears inverse over the value for the switching point.
4. Set the required switching point with the *UP* or *DOWN* keys.
5. Press the *Enter* key to accept the value.
6. Set the value for the switching differential in the same way.
7. Press the *Escape* key as often as necessary to return to the main menu.



## 7.5 Configuring the machine for local mode

In local mode the machine is controlled with the system pressure setpoints p1 or p2. The controller is provided with the following modes of operation:

Operating mode	Description	See
p1	The machine is controlled by system pressure set-point p1	7.5.3.3
p2	The machine is controlled by system pressure set-point p2	
p1/p2 clock	The changeover between p1 and p2 is regulated by a clock program	7.5.2
p1/p2 cycle	The changeover between p1 and p2 is regulated by a timer program	7.5.3

Tab. 19 Operating modes in local mode

Instructions for setting up system pressure setpoints are given in section 7.2.

### Overview

- If not activated, enter password for level 4
- Select menu option configuration > pressure settings > load control
- Set/change the clock program (see section 7.5.2)  
or  
Set/change the timer (see section 7.5.3)
- Select local mode

### 7.5.1 Select menu option configuration > pressure settings > load control

Condition: password level 4 is activated

1. In the main menu, keep pressing the *UP* key until `configuration` appears in the third line of the display.
2. Press the *Enter* key.  
`pressure settings` appears in the display.
3. Press the *Enter* key.
4. Press the *DOWN* key until `load control` appears.
5. Press the *Enter* key.  
The menu option `load control` is now selected.

### 7.5.2 Configuring the system pressure setpoint changeover using the clock.



Keep to the order of the configuration!

- ▶ First set up the clock program and then the operating mode.

### Overview

- If not activated, enter password for level 4
- Set the day of the week for the first switching point (delete any existing clock program)
- Entering the time of the first switching point
- Select the system setpoint pressure for the first switching point p1 or p2.
- Set up any further switching points.
- Select operating mode p1/p2 clock, see section 7.5.3.3



When a clock program is first set up, note the ON and OFF times on a sheet of paper first.

As well as individual weekdays, the following cycles are also available: Mon - Thu, Mon - Fri, Mon- Sat, Mon - Sun, Sat - Thu.

**Example:**

- Peak load period: weekdays 06:30 - 17:00, Fridays 06:30 - 16:00;
- Low load period: Midday from 12:00 to 13:00 and the remaining period

The clock program is set up using the following switching points:  
(a maximum of 10 switching points are available):

No.	Weekday	Time	System pressure setpoint
01	Mon - Fri	06:30	p1 on
02	Mon - Fri	12:00	p2 on
03	Mon - Fri	13:00	p1 on
04	Mon - Thu	17:00	p2 on
05	Fri	16:00	p2 on

Tab. 20 Example of system pressure changeover switching points

**Setting the day of the week for the first switching point**

Condition: password level 4 is activated,  
menu option configuration > pressure settings > load control is selected (see section 7.5.1)

1. Keep pressing the *DOWN* key until `settings` appears.

```

88psi 180°F
. . .
Settings
- - - - -
    
```

*start of the settings*

2. Press the *DOWN* key again until the following is displayed:

```

88psi 180°F
- - - - -
* p1/p2 clock <
. . .
    
```

3. Press the *Enter* key.

```

88psi 180°F
* p1/p2 clock
reset: n <
. . .
    
```

**Deleting the existing clock program:**

4. If at first an existing clock program is to be deleted, press the *Enter* key again and then the *UP* key.

The display changes to `reset: y`.

5. Press the *Enter* key.

The display changes to `reset : n`. The clock program is now deleted.

6. Keep pressing the *DOWN* key until the following is displayed:

88psi 180°F	
- - - - -	
01 n.a. <	<i>the first switching point is not active</i>
00:00	<i>start time for the first switching point</i>

7. Press the *Enter* key.
8. Press the *UP* key until `01 Mon-Fri` appears and confirm with the *Enter* key.

**Setting the time of the first switching point**

9. Press the *DOWN* key.
10. Press the *Enter* key.

88psi 180°F	
01 Mon-Fri	<i>weekday setting</i>
00:00 <	<i>actual start time</i>
p1 on	

11. First set the hours and then the minutes with the *DOWN* or *UP* keys, confirming each setting with the *Enter* key.

**Setting the system pressure setpoint for the first switching point**

12. Press the *DOWN* key.
13. Press the *Enter* key and select p1 or p2 with the *UP* or *DOWN* keys (not necessary in this example).
14. Set up the remaining switching points in the same way.  
The clock program is now finished.
15. Select operating mode p1/p2 clock (see section 7.5.3.3)
16. Press the *Escape* key as often as necessary to return to the main menu.

**7.5.3 Configuring the system pressure setpoint changeover using the timer.**

**Overview**

- If not activated, enter password for level 4
- Delete the old timer configuration, if necessary
- Setting up p1 and p2 timer periods
- Select the start times for p1 and p2
- Select operating mode p1/p2 timer, see section 7.5.3.3

**7.5.3.1 Setting up p1 and p2 timer periods**



Keep to the order of the configuration. Make sure operating mode p1/p2 timer is not activated when configuring the timer periods.

- ▶ Configure the timer first and then select the operating mode or select another operating mode first.

Condition: password level 4 is activated,  
menu option configuration > pressure settings > load control is selected.

1. Keep pressing the *DOWN* key until *settings* appears.

```

88psi 180°F
. . .
Settings
- - - - -
    
```

*start of the settings*

2. Keep pressing the *DOWN* key until the following is displayed:

```

88psi 180°F
* p1/p2 cycle
p1: 10h | 10h <
p2: 18h | 18h
    
```

*timer period p1| expiring period (example)*  
*timer period p2| expiring period (example)*

3. Press the *Enter* key.
4. Use the *DOWN* key or the *UP* key to set the timer period p1 and confirm by pressing *Enter*.
5. Press the *DOWN* key.
6. Press *Enter* and set timer period p2 with the *DOWN* or *UP* key.
7. Confirm the setting with the *Enter* key.

### 7.5.3.2 Selecting the start times for p1 and p2

1. Press the *DOWN* key.

```

88psi 180°F
p2: 7h ! 7h
-> 1. Start p1 <
09:00
    
```

*start with p1 (example)*  
*start time*

2. If the timer period is to start with p2, press *Enter* and select start p2 with the *DOWN* or *UP* key.
3. Press the *Enter* key.
4. Press the *DOWN* key.
5. Press *Enter* and set timer period p2 with the *DOWN* or *UP* key.
6. Confirm the setting with the *Enter* key.

The timer is now configured.

### 7.5.3.3 Selecting local mode

Condition: password level 4 is activated,  
menu option configuration > pressure settings > load control is selected,  
the clock program and/or timer are set up.

1. Press the *Enter* key.

2. Press the *DOWN* key.
3. Press the *Enter* key.  
The cursor appears inverse over the operating mode.
4. Press the *UP* or *DOWN* key to select the required operating mode (p1, p2, p1/p2 clock or p1/p2 cycle).
5. Press the *Enter* key to accept the operating mode.  
The actual operating mode is displayed.
6. Press the *Escape* key as often as necessary to return to the main menu.

## 7.6 Configuring the machine for operation in sequence

### 7.6.1 List of the various sequencing modes

The controller is provided with several methods of sequencing with other controllers:

Method	Description	Section
Profibus	The controller (and therefore the machine) receives the instruction LOAD, IDLE or local mode, for example, via the Profibus master (e.g. SAM or VESIS). The system pressure setpoints p1 and p2 have no relevance when the LOAD/IDLE mode instruction is received.	7.6.2
Master-Slave	Two SIGMA CONTROL controllers are working in Master-Slave-mode. The slave receives the instruction from master via the RS 485 interface to change between system pressures p1 or p2.	7.6.4
Sequencing mode via remote contact	Sequencing via a remote contact is another method of controlling the machine externally. There are three possibilities:	
	– LOAD remote contact: The machine is switched to LOAD or IDLE mode by an input signal from a master controller (e.g. a MIC 4000). The system pressure setpoints p1 and p2 have no relevance.	7.6.5
	– Local / LOAD remote contact The machine is switched to LOAD/IDLE modes or local mode by a master controller (e.g. an MVS 8000) via two inputs.	7.6.6
	– p1/p2 remote contact The signal for the change from system pressure setpoint p1 to p2 is initiated by an input contact.	7.6.7
Sequencing with machines controlled by the pressure switch	If the machine is operating in sequence with a machine controlled by a pressure switch the following two methods can be used:	7.6.8
	– On machines supplying an equal air delivery SIGMA CONTROL controls the pressure switch via a volt-free output.	7.6.8.1
	– On machines supplying an unequal air delivery the pressure ranges are matched to each other.	7.6.8.2
	To finalise, some examples of clock programs for equal loading of the machines are given.	7.6.8.3

Tab. 21 Table of controllers working in sequence

**7.6.2 Configuring Profibus mode (SAM or VESIS)**

**Overview**

- Make the electrical connections
- Set operating mode p2
- Configure the Profibus interface
- Activate the *remote* key

**7.6.2.1 Make the electrical connections**

**Profibus DP pin assignments**

- ▶ Connect the bus subscribers one after the other according to the pin assignment below.
- ▶ Connect the screening to the plug housings at both ends.

Pin	Connections
1	spare
2	spare
3	Profibus connection B
4	RTS TTL signal
5	ground
6	+ 5 V for interface P5
7	spare
8	Profibus connection A
9	spare

Tab. 22 Profibus DP pin assignments

**Wiring the interface plug**

- ▶ Switch in the terminating resistor in the plugs of the first and last subscribers to the Profibus.

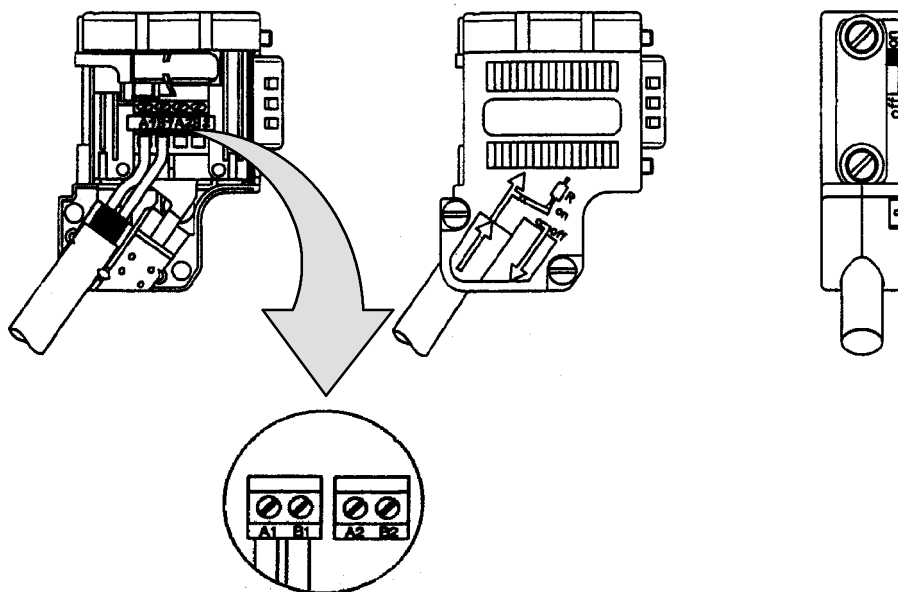

Fig. 3 Wiring the Profibus plug

Wiring possibilities for machine sequencing (excerpt)

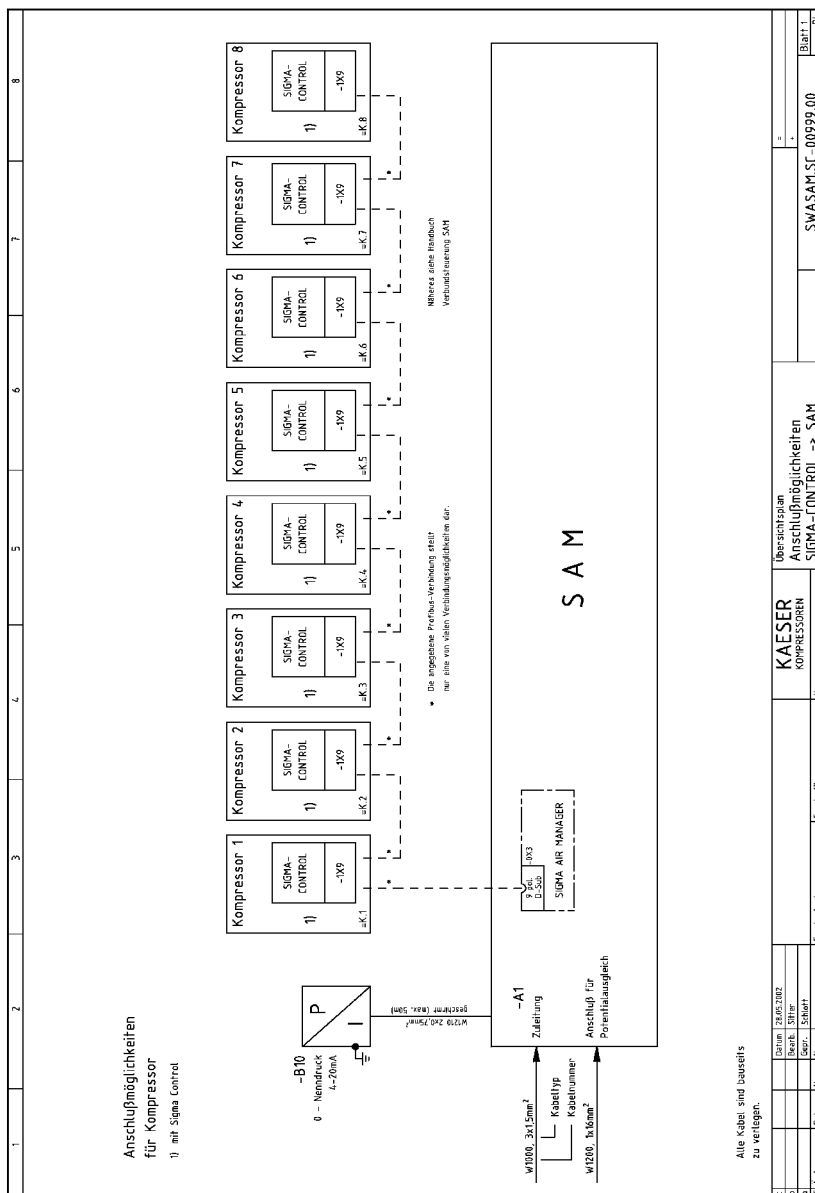

Fig. 4 Example of connections for sequencing with SAM

7.6.2.2 Setting operating mode p2



When automatic mode is changed to manual mode at the bus controller, SIGMA CONTROL changes into the preset remote mode. In such a case it is preferable to set the operating mode to remote mode p2.

- ▶ When setting up system pressure setpoint p2 note that under certain circumstances several machines will be set to local mode (Anpassung des Netz-Solldrucks, siehe Abschnitt 7.2).

Condition: password level 4 is activated,  
menu option configuration > pressure settings > load control is selected,

1. Keep pressing the *UP* or *DOWN* key until `remote` mode appears in the second line of the display.

```

88psi 180°F
remote mode
->p1 < actual operating mode in remote mode
. . .

```

2. Press the *Enter* key.  
The cursor appears inverse over the operating mode.
3. Set operating mode p2 with the *UP* key or the *DOWN* key.
4. Press the *Enter* key to accept the operating mode.
5. If required, set system pressure setpoint p2 (see section 7.2).

### 7.6.2.3 Configuring the Profibus interface for SAM/VESIS

#### Overview

- Selecting the Profibus interface
- Assign the slave address
- If required, set reaction should a bus alarm (bus timeout) occur
- If required, assign an output contact for the bus alarm message (see machine circuit diagram for a spare output)

Condition: password level 4 is activated,  
the electrical connection to the bus master is made.

#### Selecting the Profibus interface

1. In the main menu, keep pressing the *UP* key until `communication` appears in the third line of the display.
2. Press the *Enter* key.
3. Keep pressing the *DOWN* key until `Profibus` appears in the third line of the display.
4. Press the *Enter* key.

```

Profibus
-> n.a. < Profibus is inactive
Run ### | F 0

```

5. Press the *Enter* key again.
6. Keep pressing the *UP* key until `Send+Receive` appears in the display.
7. Press the *Enter* key.  
If no electrical connection to the bus has been made up to this point the message `bus alarm` appears.
8. Acknowledge the message and check the electrical connections.



**Assign the slave address**



When sequencing with SAM the slave address is determined as follows: Compressor number used in SAM + 2. The permissible range of addresses is between 3 to 126.

9. Keep pressing the *DOWN* key until the following is displayed:

```

88psi 180°F
. . .
Slave no.: 2<  actual slave address assigned
. . .

```

10. Press the *Enter* key.

The cursor appears inverse over the slave address.

11. Select the required slave address with the *UP* or *DOWN* keys and confirm with the *Enter* key.

**Setting reaction if a bus alarm (bus timeout) occurs**



The controller can react in two ways when a bus alarm occurs:  
 Automatic: the controller remains in remote mode and tries to connect to the bus.  
 Manual: the controller changes to the preset local mode. Sequencing mode is started again by pressing the *Remote* key.

Exchange of data with a Profibus connection takes place in three fixed cycles. The Profibus connection can be monitored with the help of the cycle time:

The bus connection is considered to be interrupted if no data is exchanged between the bus master and the controller (as bus subscriber) after expiry of a set time period (timeout). If the period for bus timeout is set to zero then the bus alarm is inactive.

12. Keep pressing the *DOWN* key until the following is displayed:

```

88psi 180°F
* bus alarm
start td: 15.0s <  delay period*
timeout: 5.00s  actual bus timeout setting

```

*\* after switching on the power supply the bus alarm can be suppressed for the "start td period.*

13. Keep pressing the *DOWN* key until *timeout* appears in the third line of the display.
14. Press the *Enter* key.
15. Change the setting for bus timeout with the *DOWN* or *UP* key.  
If the bus alarm is to be deactivated, set *timeout* to 0.00s.
16. Save the settings with the *Enter* key.

**Setting the output contact for the bus alarm**

The bus alarm can be sent to a remote control centre or device via a volt-free contact.

17. Keep pressing the *DOWN* key until the following is displayed:

88psi 180°F	
Restart: auto.	<i>reaction during a bus alarm*</i>
-> n.a. <	<i>bus alarm output inactive</i>
. . .	

\* the controller's reaction during a bus alarm can only be changed by KAESER service personnel.

18. Press the *Enter* key.  
The cursor appears inverse over n.a.
19. Choose a spare output with the *UP* key.
20. Press the *Enter* key to confirm the output.
21. Save the settings with the *Enter* key.

#### Saving data

The settings are automatically saved in an EEPROM that is no-volt safe. The settings are still available even if the buffer battery discharges completely.

#### 7.6.2.4 Activating the remote key

Condition: password level 4 is activated,  
the menu option communication > Profibus is selected.

- Keep on pressing the *UP* or *DOWN* key until `remote key` appears in the third line of the display.
- Press the *Enter* key.  
The cursor appears inverse over the `y` (*remote key active*) or `n` (*remote key inactive*).
- Use the *UP* key or *DOWN* key to select `y` and confirm with *Enter*.  
The remote key function is activated and can be used.
- Press the *remote* key to enable remote mode.

#### 7.6.3 Configuring the Profibus interface without SAM/VESIS



Further data from KAESER is needed to configure the Profibus interface (xls- and gsd-files). If these data are not available, contact KAESER Service.

#### Overview

- Selecting the Profibus interface
- Assign the slave address
- If required, set reaction should a bus alarm (bus timeout) occur
- If required, assign an output contact for the bus alarm message (see machine circuit diagram for a spare output)

Condition: password level 4 is activated,  
the electrical connection to the bus master is made,  
the data required from KAESER are available.

#### Selecting the Profibus interface

- In the main menu, keep pressing the *UP* key until `communication` appears in the third line of the display.

2. Press the *Enter* key.
3. Keep pressing the *DOWN* key until `Profibus` appears in the third line of the display.
4. Press the *Enter* key.

```
Profibus
-> n.a.      <  Profibus is inactive
Run  ### | F 0
```

5. Press the *Enter* key again.
6. Press the *UP* key until `send` appears in the display.
7. Press the *Enter* key.  
If no electrical connection to the bus has been made up to this point the message `bus alarm` appears.
8. Acknowledge the message and check the electrical connections.

#### **Assign the slave address**

9. Keep pressing the *DOWN* key until the following is displayed:

```
Profibus
. . .
Slave no.:  2<  actual slave address assigned
. . .
```

10. Press the *Enter* key.  
The cursor appears inverse over the slave address.
11. Select the required slave address with the *UP* or *DOWN* keys and confirm with the *Enter* key.

#### **Further steps**

Carry out further configuration as outlined in section 7.6.2.3:

- If required, set reaction should a bus alarm (bus timeout) occur
- If required, assign an output contact for the bus alarm message (see machine circuit diagram for a spare output)

### **7.6.4 Configuring master-slave mode**

#### **7.6.4.1 Examples showing master-slave applications**

In master-slave mode two SIGMA CONTROL controllers operate in sequence to supply a common air main. The master controls the machine with the controller configured as a slave and provides the instruction for the air system pressure setpoint.

#### **Example: two machines with differing air deliveries**

Master's local operating mode **p1/p2 clock**:

- Toggled between system pressure setpoints p1 and p2 by a clock program.
- At peak load times (high air demand) pressure is regulated to system pressure setpoint p1. During periods of low air demand, e.g. at weekends, pressure is regulated to system pressure setpoint p2.
- The machine with the lesser air delivery is the slave. At peak load times the machine is only cut in under conditions of high air demand. During periods of low air demand the machine with the lesser air delivery is cut in more often.

**Example: two machines with equal air deliveries**

- Master's local operating mode **p1/p2 cycle**:  
(toggled between system pressure setpoints p1 and p2 by a timer).  
The timer ensures even loading of both machines. The system pressure setpoints are set the same for both machines.
- During cycle 1 master regulates on p1 and instructs slave to regulate on p2.  
During cycle period 2 master regulates on p2 and instructs slave to regulate on p1.



Both controllers must have the same software version to allow two Sigma Controls to work in master-slave mode.

**7.6.4.2 Configuration procedure**

The configuration procedure is described in the following sections:

Controller	Procedural step	Section
Both	Make the electrical connections	7.6.4.3
Both	Setting up the appropriate system pressure setpoints p1 and p2 taking air losses in the air main into account.	7.6.4.4
Master	Setting up switching times for the clock program or setting up switching times for the timer	7.6.4.5 7.6.4.6
Master	Selecting the type of LOAD control (clock program or timer) in local mode	7.6.4.7
Slave	Setting p1/p2 remote mode via RS485	7.6.4.8
Slave	Activating the remote key	7.6.4.9
Both	Activating master or slave	7.6.4.10

Tab. 23 Master-slave configuration procedure

**7.6.4.3 Make the electrical connections**
**RS 485 pin assignment**

1. Make the electrical connections as shown in the table below.
2. Connect the screening to the plug housings at both ends.
3. Wire the jumpers in the plug as shown in Fig. 5.

Pin	Connections	Remarks
1	terminating resistor RA	(integrated in the controller)
2	reserved	
3	difference signal B	
4	reserved	
5	reserved	
6	reserved	
7	terminating resistor RA	(integrated in the controller)
8	difference signal A	
9	reserved	

Tab. 24 RS 485 pin assignment

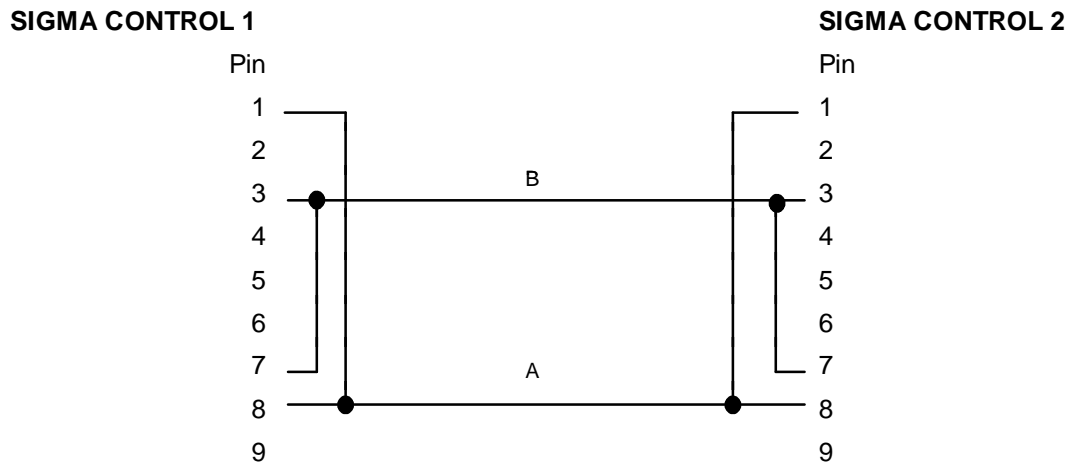

Fig. 5 Electrical connections between the two controllers

#### 7.6.4.4 Both: setting up system pressure setpoints p1 and p2

Condition: password level 4 is activated,  
 menu option configuration > pressure settings > compressor is selected.

1. Press the *Enter* key to configure the system pressure setpoint for p1.
2. Set the value with the *UP* key or the *DOWN* key.
3. Press the *Enter* key to accept the value.
4. Configure the switching difference p1 SD in the same way.
5. If necessary, configure the value for p2 in the same way.
6. Press the *Escape* key as often as necessary to return to the main menu.

Further information on setting up the pressure parameters is found in section 7.2.

#### 7.6.4.5 Master: configuring the system pressure setpoint changeover using the clock.



Keep to the order of the configuration!

- ▶ First set up the clock program and then select the operating mode.



When a clock program is first set up, note the start times for the system pressure setpoints on a sheet of paper first.

As well as the individual weekdays, the following cycles are also available:  
 Mon - Thu, Mon - Fri, Mon- Sat, Mon - Sun, Sat - Thu.

The settings for a clock program are described in more detail using the example given in section 7.5.2.

#### Overview

- Entering the weekday for the first switching point
- Entering the time of the first switching point
- Set the system pressure setpoint for the first switching point
- Set up any further switching points.
- Select operating mode p1/p2 clock (see section 7.6.4.7)

Condition: password level 4 is activated,  
menu option configuration > pressure settings > load control is selected.

### Entering the weekday for the first switching point

1. Keep pressing the *DOWN* key until \*p1/p2 clock appears in the third line of the display.
2. Press the *Enter* key.

```
88psi 180°F
* p1/p2 clock
  reset: n  <
  . . .
```

3. If at first an existing clock program is to be deleted, press the *Enter* key again and then the *UP* key.

The display changes to reset: y.

4. Press the *Enter* key.

The display changes to reset: n. The clock program is now deleted.

5. Keep pressing the *DOWN* key until the following is displayed:

```
88psi 180°F
- - - - -
01 n.a.      <  first switching point for the weekday
00:00       start time for the first switching point
```

6. Press the *Enter* key.
7. Press the *UP* key to set the weekday for the first switching point and confirm with the *Enter* key.

### Entering the time of the first switching point

8. Press the *DOWN* key.
9. Press the *Enter* key.

```
88psi 180°F
01 Mon-Fri   weekday settings (example)
00:00       actual start time
p1 on
```

10. First set the hours and then the minutes with the *DOWN* or *UP* keys, confirming each setting with the *Enter* key.

### Set the system pressure setpoint for the first switching point

11. Press the *DOWN* key.
12. Press the *Enter* key and select p1 or p2 with the *UP* or *DOWN* keys.
13. Set up the remaining switching points in the same way.  
The clock program is now finished.
14. Select operating mode p1/p2 clock (see section 7.6.4.7)
15. Press the *Escape* key as often as necessary to return to the main menu.

7.6.4.6 Master: configuring the system pressure setpoint changeover using the timer.



Keep to the order of the configuration!

- ▶ First set up the timer and then select the operating mode.

**Overview**

- Setting up p1 and p2 timer periods
- Select the start times for p1 and p2
- Select operating mode p1/p2 timer (see section 7.6.4.7)

**Setting up p1 and p2 timer periods**

Condition: password level 4 is activated,  
menu option configuration > pressure settings > load control is selected.

1. Keep pressing the *DOWN* key until the following is displayed:

```

88psi 180°F
* p1/p2 cycle
p1: 10h | 10h < timer period p1| expired timer period (example)
p2: 18h | 18h
    
```

2. Confirm the setting with the *Enter* key.
3. Use the *DOWN* key or the *UP* key to set the timer period p1 and confirm by pressing *Enter*.
4. Press the *DOWN* key.
5. Press *Enter* and set timer period p2 with the *DOWN* or *UP* key.
6. Confirm the setting with the *Enter* key.

**Selecting the start times for p1 and p2**

7. Press the *DOWN* key.

```

88psi 180°F
p2: 7h | 7h
-> 1. Start p1 < actual setting: start with p1 (example)
09:00 actual start time setting
    
```

8. If the timer period is to start with p2, press *Enter* and select start p2 with the *DOWN* or *UP* key.
9. Press the *Enter* key.
10. Press the *DOWN* key.
11. Press *Enter* and set timer period p2 with the *DOWN* or *UP* key.
12. Confirm the setting with the *Enter* key.  
The timer is now configured.
13. Select operating mode p1/p2 timer (see section 7.6.4.7)
14. Press the *Escape* key as often as necessary to return to the main menu.



Resetting the timer period!

- ▶ Do not switch the machine on and off with the main switch, otherwise the timer period will always be reset to zero.

#### 7.6.4.7 Master: selecting local mode

Condition: password level 4 is activated,  
menu option configuration > pressure settings > load control is selected,  
the clock program and/or timer are set up.

1. Press the *Enter* key.

```
88psi 180°F
local mode
->p1          <  operating mode in local mode
. . .
```

2. Press the *Enter* key.  
The cursor appears inverse over the operating mode.
3. Press the *UP* or *DOWN* key to select the required local mode (p1, p2, p1/p2 clock or p1/p2 cycle).
4. Press the *Enter* key to accept the operating mode.  
The actual operating mode is displayed.

#### 7.6.4.8 Setting remote mode via RS 485

Condition: password level 4 is activated,  
menu option configuration > pressure settings > load control is selected.

1. Keep pressing the *UP* or *DOWN* key until `remote mode` appears in the second line of the display.
2. Press the *Enter* key.  
The cursor appears inverse over the operating mode.

```
88psi 180°F
remote mode
-> p1          <  actual operating mode
remote key: n
```

3. Use the *DOWN* key or the *UP* key to select operating mode `p1/p2 RS485` and confirm by pressing *Enter*.

#### 7.6.4.9 Slave: activating/deactivating the remote key

Condition: password level 4 is activated  
menu option configuration > pressure settings > load control is selected,

1. Keep pressing the *UP* or *DOWN* key until `remote-key: y/n` appears in the third line of the display.



2. Press the *Enter* key.  
The cursor appears inverse over the  $\gamma$  (*remote* key active) or  $n$  (*remote* key inactive).
3. Use the *UP* key or *DOWN* key to select  $\gamma$  and confirm with *Enter*.  
The remote key function is activated and can be used.
4. Press the *remote* key to enable remote mode.

#### 7.6.4.10 Both: configuring the RS 485 interface

##### Overview

- Selecting the communication menu option
- Determine master and slave
- Saving the settings

Condition: password level 4 is activated.

##### Selecting the communication menu option

1. In the main menu, keep pressing the *UP* key until *communication* appears in the third line of the display.
2. Press the *Enter* key.
3. Keep pressing the *DOWN* key until RS485 appears in the third line of the display.

```
88psi 180°F
RS232
RS485 <
Profibus
```

4. Press the *Enter* key.

```
RS485
-> n.a. < interface is not active
Run ### | F 0
```

##### Setting the controller as master or slave

5. Press the *DOWN* or *UP* key until *->n.a* appears in the third line of the display.
6. Press the *Enter* key.  
A cursor appears inverse over *->n.a*.
7. Press the *UP* key once or twice to select *Slave* or *Master* and confirm with the *Enter* key.  
The controller now starts the interface test. After *Run* there is a 0–256 counter. If a zero appears after the *F* the machine is OK.
8. If no zero appears: check the cable connections or the settings on the *Master* and *Slave* controllers.

```
RS485
-> n.a. <
Run 0 | F 0 interface test counter
```

**Saving the settings**

The settings are automatically saved in an EEPROM that is no-volt safe. The settings are still available even if the buffer battery discharges completely.

**7.6.5 Configuring sequencing mode using the LOAD remote contact (e.g. MIC 4000)**

**Overview**

- Make the electrical connections
- Setting the LOAD remote contact operating mode and assigning the input
- Adjusting the pressure increase pE settings, if required
- Activate the *remote* key

**7.6.5.1 Electrical connections for LOAD remote contact (excerpt)**

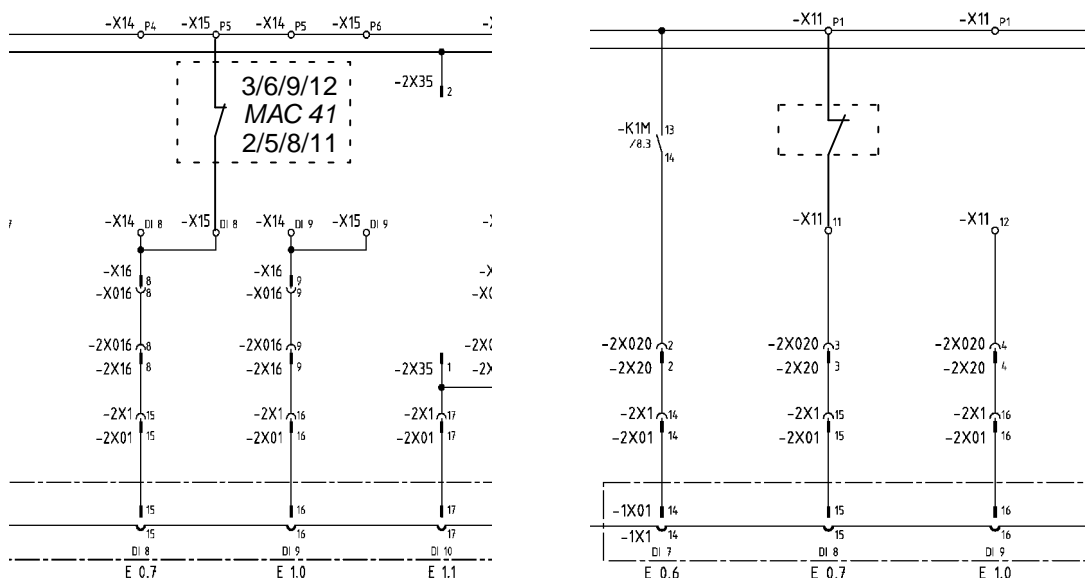

Fig. 6 LOAD remote contact wiring diagram

Example:

Compressors with ribbon cable adapter

DI 0.7 LOAD/IDLE external

Example:

Compressors without a ribbon cable adapter; SX, SM and SK before modification to spring terminals

DI 0.7 LOAD/IDLE external

**7.6.5.2 Setting the LOAD remote contact operating mode and assigning the remote contact input**

Condition: password level 4 is activated, menu option configuration > pressure settings > load control is selected.

**Setting the LOAD remote contact operating mode**

1. Keep pressing the *UP* or *DOWN* key until *remote* mode appears in the second line of the display.

2. Press the *Enter* key.

The cursor appears inverse over the operating mode.

```
88psi 180°F
remote mode
-> p1          <  actual operating mode
remote key: n
```

3. Use the *DOWN* key or the *UP* key to select operating mode load RC and confirm by pressing *Enter*.

#### Assigning the remote contact input

4. Keep pressing the *DOWN* key until the following is displayed:

```
88psi 180°F
* idle - load
RC -> DI0.7 <  Standard: DI 0.7
. . .
```

5. Press the *Enter* key.  
The cursor appears inverse over n.a.
6. Use the *DOWN* key or the *UP* key to select an input for the remote contact and confirm by pressing *Enter*.  
The operating mode is now configured.

#### 7.6.5.3 Setting the pressure increase pE

Instructions for setting up the pressure increase parameter pE are given in section 7.2.3.3. Detailed information on this pressure parameter is found in section 7.2.1.

#### 7.6.5.4 Activating the remote key

Condition: password level 4 is activated,  
menu option configuration > pressure settings > load control is selected.

1. Keep pressing the *UP* or *DOWN* key until remote-key: n appears in the third line of the display.
2. Press the *Enter* key.  
The cursor appears in inverse over the n (*remote* key not activated).
3. Use the *UP* key or *DOWN* key to select y and confirm with *Enter*.  
The *remote* key is activated and can be used.
4. Press the *remote* key to enable remote mode.

#### 7.6.6 Configuring sequencing mode using the local/remote contact (e.g. MVS 8000)

##### Overview

- Make the electrical connections
- Setting the local/remote contact operating mode and assigning the input
- Configure the operating mode in local mode, if required
- Activate the **remote** key

7.6.6.1 Make the electrical connections



Use output O0.3 “control on” for the “Alarm machine X” message to the MVS 8000 to ensure open circuit protection!

- ▶ Wire the “motor running” (O0.5) and “control on” (O0.3) messages from the compressor to the MVS 8000.

Wiring diagram (excerpt)

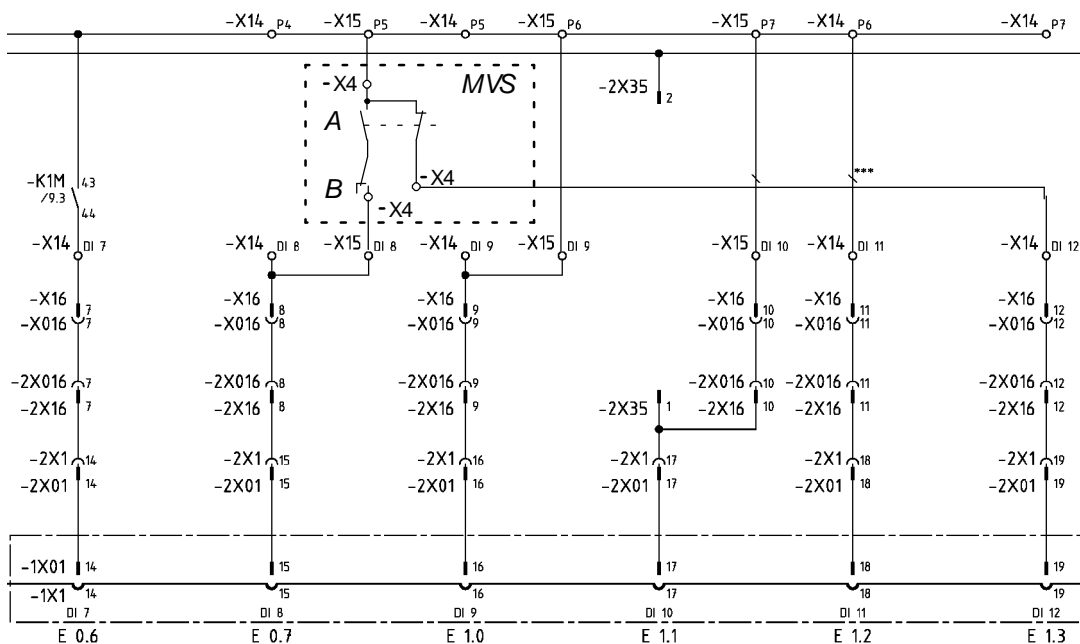

Fig. 7 Wiring diagram for local/remote contact

- A Changeover between automatic and manual modes
- B LOAD/IDLE contact in the MVS
- DI 0.7 external LOAD/IDLE
- DI 1.3 local and LOAD remote contact LOAD-control changeover

7.6.6.2 Activating the remote key

Condition: password level 4 is activated,  
menu option configuration > pressure settings > load control is selected.

1. Keep pressing the UP or DOWN key until remote-key: n appears in the third line of the display.
2. Press the Enter key.  
The cursor appears in inverse over the n (remote key not activated).
3. Use the UP key or DOWN key to select y and confirm with Enter.  
The remote key is activated and can be used.
4. Press the remote key to enable remote mode.

**7.6.6.3 Setting the local/remote contact operating mode and assigning the input**

Condition: password level 4 is activated,  
menu option configuration > pressure settings > load control is selected.

**Setting the local/remote operating mode**

1. Keep pressing the *UP* or *DOWN* key until `remote` mode appears in the second line of the display.
2. Press the *Enter* key.

The cursor appears inverse over the operating mode.

```

88psi 180°F
remote mode
-> p1          <  actual operating mode
remote key:  n
  
```

3. Use the *DOWN* key or the *UP* key to select operating mode `loc.-load RC` and confirm by pressing *Enter*.

**Assigning the remote contact input**

4. Keep pressing the *DOWN* key until the following is displayed:

```

88psi 180°F
* loc.-loadRC
RC      -> n.a. <  no input assigned
. . .
  
```

5. Press the *Enter* key.  
The cursor appears inverse over `n.a.`
6. Use the *DOWN* key or the *UP* key to select an input for the remote contact and confirm by pressing *Enter*.  
The operating mode is now configured.

**7.6.6.4 Selecting local mode p2 parameter**



Operating mode p2 is normally selected for local operation.

- ▶ When setting up system pressure setpoint p2 note that under certain circumstances several machines will be set to local mode (Anpassung des Netz-Solldrucks, siehe Abschnitt 7.2).

Condition: password level 4 is activated,  
menu option configuration > pressure settings > load control is selected,

1. Keep on pressing the *UP* or *DOWN* key until `local` mode appears in the second line of the display.

```

88psi 180°F
local mode
->p1          <  actual local operating mode
. . .
  
```

2. Press the *Enter* key.  
The cursor appears inverse over the operating mode.
3. Set operating mode p2 with the *UP* key or the *DOWN* key.
4. Press the *Enter* key to accept the operating mode.
5. If required, set system pressure setpoint p2 (see section 7.2).

### 7.6.7 Configuring the sequencing mode from the remote contact

The signal for the change from system pressure setpoint p1 to p2 is initiated via an input contact.

If there is a signal at the input then system pressure is regulated on setpoint p2.

#### Overview

- Setting up remote contact RC p1/p2 operating mode
- Assigning the remote contact input
- Activate the **remote** key

#### 7.6.7.1 Setting up remote contact RC p1/p2 operating mode

Condition: password level 4 is activated  
the electrical connections are made,  
menu option configuration > pressure settings > load control is selected.

1. Keep pressing the *UP* or *DOWN* key until `remote mode` appears in the second line of the display.
2. Press the *Enter* key.

The cursor appears inverse over the operating mode.

```

88psi 180°F
remote mode
-> p1          <  actual operating mode
remote key: n
  
```

3. Use the *DOWN* key or the *UP* key to select operating mode p1/p2 RC and confirm by pressing *Enter*.

#### 7.6.7.2 Assigning the remote contact input

A spare input can be found in the machine circuit diagram.

4. Keep pressing the *DOWN* key until the following is displayed:

```

88psi 180°F
* p1/p2 RC
RC      -> n.a. <  no input assigned
. . .
  
```

5. Press the *Enter* key.  
The cursor appears inverse over n.a.

6. Use the *DOWN* key or the *UP* key to select an input for the remote contact and confirm by pressing *Enter*.

The operating mode is now configured.

### 7.6.7.3 Activating the *remote* key

Condition: password level 4 is activated,  
menu option configuration > pressure settings > load control is selected.

1. Keep pressing the *UP* or *DOWN* key until `remote-key: y/n` appears in the third line of the display.
2. Press the *Enter* key.  
The cursor appears inverse over the *y* (*remote* key active) or *n* (*remote* key inactive).
3. Use the *UP* key or *DOWN* key to select *y* and confirm with *Enter*.  
The *remote* key is activated and can be used.
4. Press the *remote* key to enable remote mode.  
The operating mode is now configured.

## 7.6.8 Sequencing mode with machines controlled by the pressure switch

### 7.6.8.1 Configuring sequencing mode from a volt-free contact

Requirement:

A machine with SIGMA CONTROL (e.g. model BSD) and a conventional machine without SIGMA CONTROL of the same capacity are to run in sequence as base load and/or peak load machines.

Proposal:

- Set the clock program and/or timer on SIGMA CONTROL
- Select local operating mode **p1/p2 clock** or **p1/p2 timer**
- The system pressure setpoints p1 and p2 should correspond to the required values. They must be identical to the pressure switch settings on the conventional machine.
- To make the p1/p2 pressure setpoint changeover between the two machines possible the local operating mode selected has to be assigned a volt-free contact. An auxiliary contactor can be energized via this contact to activate the pressure switches for p1 and p2 on the conventional compressor. See example wiring diagram below.

Example wiring diagram (excerpt)

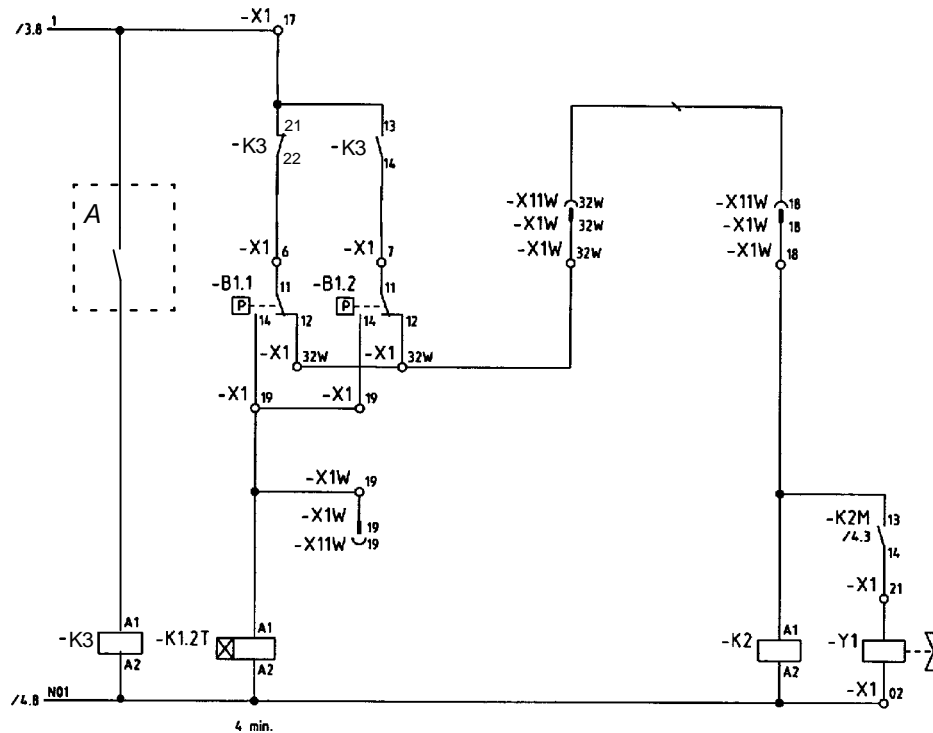

Fig. 8 Wiring diagram for machine with pressure switch regulation

A: SIGMA CONTROL volt-free contact, K3: auxiliary contactor

B1.1: pressure switch for pressure setpoint p2, B1.2: pressure switch for pressure setpoint p1

Contact A open: SIGMA CONTROL runs with pressure setpoint p2,

Contact A closed: SIGMA CONTROL runs with pressure setpoint p1

### Overview

- Make the electrical connections
- Setting pressure setpoints p1 and p2
- Configure/adjust local operating mode
- Assigning the volt-free relay contact
- Selecting local mode

### Setting pressure setpoints p1 and p2

Condition: password level 4 is activated  
the electrical connections have been made

1. Select menu options configuration > pressure settings > compressor (see section 7.2.2)
2. Press the *Enter* key to configure the system pressure setpoint for p1.
3. Set the value with the *UP* key or the *DOWN* key.
4. Press the *Enter* key to accept the value.



5. Configure the switching difference p1 SD in the same way.
6. If necessary, configure the value for p2 in the same way.
7. Press the *Escape* key as often as necessary to return to the main menu.

**Configuring local mode**

A detailed description for setting up a clock or timer program can be found in section 7.5.

**Assigning the volt-free relay contact**

Condition: password level 4 is activated,  
an electrical connection has been made,  
(see machine circuit diagram for a spare relay contact)

1. Select menu option configuration > pressure settings > load control
2. Press the *Enter* key.
3. Keep pressing the *DOWN* key until the following is displayed:

```

88psi 180°F
* p1/p2 DO
          n.a. < no output assigned
. . .

```

4. Press the *Enter* key.
5. Use the *DOWN* key or the *UP* key to select the required output and confirm by pressing *Enter*.

This output can now be used for the changeover between the two pressure switches.

**Selecting local mode**

Condition: password level 4 is activated

1. Select menu option configuration > pressure settings > load control
2. Press the *Enter* key.

```

88psi 180°F
local mode
->p1          < actual local operating mode
. . .

```

3. Press the *Enter* key.  
The cursor appears inverse over the operating mode.
4. Select operating mode p1/p2 clock or p1/p2 cycle with the *UP* or *DOWN* keys.
5. Press the *Enter* key to accept the operating mode.

The actual operating mode is displayed.

**7.6.8.2 Configuring sequencing mode without an electrical connection**

Requirement:

A high capacity machine with SIGMA CONTROL (e.g. model BSD) is to work as a base load machine. A second machine (e.g. model SK) with pressure switch regulation is intended to cover the air demand during periods of low load.

Proposal:

- Select the system pressure setpoints  $p_1$  and  $p_2$  for the BSD such that the pressure switch switching points of the SK machine are in between. If  $p_2$  is activated for the periods of low load, the SK machine automatically functions as the base load machine.
- Set up the required values for a clock program on SIGMA CONTROL
- Select local operating mode  **$p_1/p_2$  clock**
- Activate the clock

**Function diagram:**

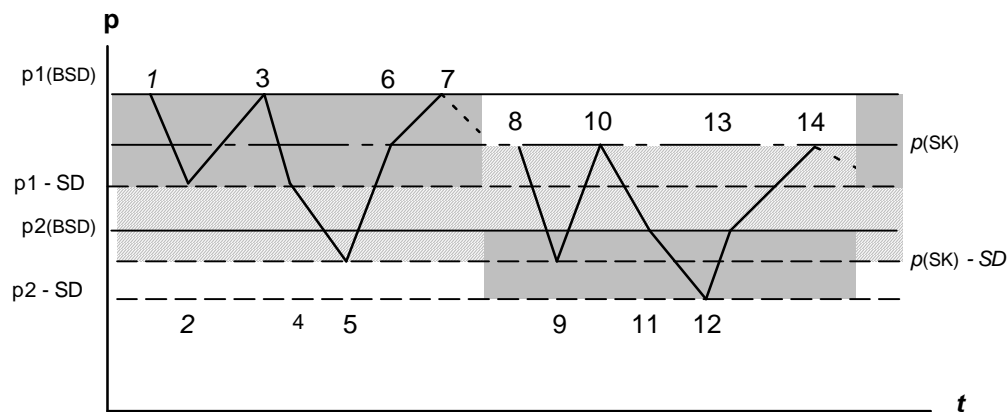

Fig. 9 Function diagram of pressure switch regulation and SIGMA CONTROL regulation

Period t1 - t7: high air demand  
*t1: air demand rises, system pressure falls*  
*t2: BSD switches to LOAD mode*  
*t3: system pressure setpoint  $p_1$  attained, BSD switches to IDLE*  
*t4: BSD switches to LOAD mode, air demand is not covered*  
*t5: SK switches additionally to LOAD mode, system pressure starts to rise*  
*t6: SK switches to IDLE mode*  
*t7: BSD switches to IDLE mode*

Period t8 - t14: low air demand  
*t8: air demand rises, system pressure falls*  
*t9: SK switches to LOAD mode*  
*t10: system pressure setpoint  $p_2$  attained, SK switches to IDLE*  
*t11: BSD switches to LOAD mode, air demand is not covered*  
*t12: SK switches to LOAD mode, system pressure starts to rise*  
*t13: SK switches to IDLE mode*  
*t14: BSD switches to IDLE mode*

### Setting pressure setpoints $p_1$ and $p_2$

Condition: password level 4 is activated.

1. Select menu options configuration > pressure settings > compressor (see section 7.2.2)
2. Press the *Enter* key to configure the system pressure setpoint for  $p_1$ .
3. Set the value with the *UP* key or the *DOWN* key.
4. Press the *Enter* key to accept the value.

5. Configure the switching difference p1 SD in the same way.
6. If necessary, configure the value for p2 in the same way.
7. Press the *Escape* key as often as necessary to return to the main menu.

**Configuring the clock program**

The clock program for the example is set up using the following switching points:  
(a maximum of 10 switching points are available):

No.	Weekday	Time	System pressure setpoint
01	Mon - Fri	06:30	p1 on
02	Mon - Fri	17:00	p2 on

Tab. 25 Example switching points

**Overview**

- Entering the weekday for the first switching point
- Entering the time of the first switching point
- Set the system pressure setpoint for the first switching point
- Set up any further switching points.

Condition: password level 4 is activated,  
the menu option configuration > pressure settings > load control is selected,  
p1/p2 clock local mode is selected.

**Entering the weekday for the first switching point**

1. Keep pressing the *DOWN* key until \*p1/p2 clock appears in the third line of the display.
2. Press the *Enter* key.

```

88psi 180°F
* p1/p2 clock
reset: n <
. . .

```

3. If at first an existing clock program is to be deleted, press the *Enter* key again and then the *UP* key.

The display changes to reset: y.

4. Press the *Enter* key.

The display changes to reset: n. The clock program is now deleted.

5. Keep pressing the *DOWN* key until the following is displayed:

```

88psi 180°F
- - - - -
01 n.a. <
00:00

```

*the first weekday switching point is inactive  
start time for the first switching point*

6. Press the *Enter* key.
7. Press the *UP* key to set the weekday and confirm with the *Enter* key.

**Entering the time of the first switching point**

8. Press the *DOWN* key.
9. Press the *Enter* key.

```

88psi 180°F
01 Mon-Fri      weekday setting
00:00 <       actual start time
p1 on
  
```

10. First set the hours and then the minutes with the *DOWN* or *UP* keys, confirming each setting with the *Enter* key.

**Selecting system setpoint pressure p1 or p2 for the first switching point.**

11. Press the *DOWN* key.
12. Press the *Enter* key and select p1 or p2 with the *UP* or *DOWN* keys.
13. Set up the remaining switching points in the same way.
14. Press the *Escape* key as often as necessary to return to the main menu.

**Selecting local mode**

Condition: password level 4 is activated.

1. Select menu option configuration > pressure settings > load control
2. Press the *Enter* key.

```

88psi 180°F
local mode
->p1 <      actual local operating mode
. . .
  
```

3. Press the *Enter* key.  
The cursor appears inverse over the operating mode.
4. Set operating mode p1/p2 with the *UP* key or the *DOWN* key.
5. Press the *Enter* key to accept the operating mode.  
The actual operating mode is displayed.

**7.6.8.3 Example of time settings for even loading**

Requirement: two machines of the same capacity are to be equally cycled



A detailed description for configuring a clock or timer program can be found in section 7.5.

**Method A: daily cycling between p1 and p2 over 24 hours.**

Condition: the system pressure setpoints p1/p2 are the same for both machines.

The compressor starts with pressure setpoint p2 at 0:00 hours. The p1/p2 changeover is decided by the timer (local mode p1/p2 cycle):

The cycle is set up using the following switching points:

- p1 cycling period: 24 h
- p2 cycling period: 24 h
- Start p2: 0:00 hours

**Method B: equal duty cycle during the day**

Condition: the system pressure setpoints p1/p2 are the same for both machines.

The p1/p2 changeover is decided by a clock program (local mode p1/p2 clock):

The clock program is set up using the following switching points:

No.	Weekday	Time	System pressure setpoint
01	Mon - Sun	00:00	p1 on
02	Mon - Sun	6:00	p2 on
03	Mon - Sun	12:00	p1 on
04	Mon - Sun	18:00	p2 on

Tab. 26 Example clock program for equal duty cycling during the day

**Method C: equal duty cycling during the week**

Condition: the system pressure setpoints p1/p2 are the same for both machines.

The p1/p2 changeover is decided by a clock program (local mode p1/p2 clock):

The clock program is set up using the following switching points:

No.	Weekday	Time	System pressure setpoint
01	Mon	00:00	p1 on
02	Mon	21:00	p2 on
03	Tue	18:00	p1 on
04	Wed	15:00	p2 on
05	Thu	12:00	p1 on
06	Fri	9:00	p2 on
07	Sat	06:00	p1 on
08	Sun	03:00	p2 on

Tab. 27 Example clock program for equal duty cycling during the week

## 7.7 Configuring PC or Modem Output

The controller is provided with an RS 232 interface that can be used for connection to a PC or a modem.

**Overview**

Configure the interface as follows:

- Make the electrical connection (see electrical diagram for the machine)
- Set the type of output
- Saving the settings

**7.7.1 RS 232 pin assignment**

- ▶ Make the electrical connections
- ▶ Connect the screening to the plug housings at both ends.

Pin	Connections
1	spare
2	receive data RxD
3	receive data RxD
4	reserved
5	ground
6	spare
7	request to send RTS
8	clear to send CTS
9	spare

Tab. 28 RS 232 pin assignment

**7.7.2 Configuring the RS 232 interface**

Condition: password level 4 is activated.

1. In the main menu, keep pressing the *UP* key until *communication* appears in the third line of the display.
2. Press the *Enter* key.

```

88psi 180°F
RS232  <
RS485

```

3. Press *Enter* to select RS 232.

```

88psi 180°F
-> n.a.  <  Interface n(ot) a(ctive)
. . .

```

4. Press the *Enter* key.
5. Press the *UP* key once or twice to select modem or data > PC.
6. Press the *Enter* key to accept the type of output.

**Saving the settings**

The settings are automatically saved in an EEPROM that is no-volt safe. The settings are still available even if the buffer battery discharges completely.

**7.8 Configuring the SMS**

If, for example, a SIGMA TELE-CARE agreement has been signed, the controller can send information to KAESER Service in SMS form to make possible a remote diagnosis. A modem must be fitted that can be connected to the phone network.

### Overview

Configure the SMS option as follows:

- Activating the SMS function
- Suppress repeat messages (filter)
- Entering the modem's phone number (modem)
- Entering company data (site location)
- Select the service centre (channel 1 (2))
- Saving the settings

#### 7.8.1 Activating the SMS function

Condition: password level 4 is activated.

1. In the main menu, keep pressing the *UP* key until *communication* appears in the third line of the display.
2. Press the *Enter* key.
3. Keep on pressing the *DOWN* key until *SMS* appears in the third line of the display.
4. Press the *Enter* key.

```
88psi 180°F
mode:  n.a.
buffer empty <
channel 1
```

*SMS inactive*

5. Press the *UP* key once.

```
88psi 180°F
*SMS status
mode:  n.a. <
buffer empty
```

6. Press the *Enter* key.
7. Press the *UP* key once or twice to select *SMS 1x* or *SMS 5x*.
8. Save the setting with the *Enter* key.



If 1st SMS is set the actual warning or alarm messages will be sent per SMS.

If SMS 5x is set, an actual process image in binary format is sent in addition. Four further SMSs are needed for this function.

#### 7.8.2 Suppress repeat messages (filter)

To suppress messages repeating at short intervals, a period of 0 - 3.600 seconds can be set during which a repeat of the same message is suppressed, i.e. is not sent.

Condition: password level 4 is activated,  
the menu option configuration > SMS is selected

1. Keep on pressing the *DOWN* key until *filter* appears in the third line of the display.

2. Press the *Enter* key.
3. Use the *DOWN* key or the *UP* key to set the required period and confirm by pressing *Enter*.

### 7.8.3 Entering the modem's phone number (modem)



Detailed information on standard settings and initialisation are given in the service manual for SIGMA AIR MANAGER-short message service (SMS).

The modem phone number and modem initialisation must be entered to finalise configuration of the modem.

Condition: password level 4 is activated.  
the menu option configuration > SMS is selected.

1. Keep on pressing the *DOWN* key until modem appears in the third line of the display.
2. Press the *Enter* key.

```
88psi 180°F
tel.modem
-> ***** <  the first six numbers (not entered)
-> *****  further 12 numbers (not entered)
```

3. Use the *DOWN* key or the *UP* key to initially enter the first six numbers and confirm each one by pressing *Enter*.
4. Scroll to the next line with the *DOWN* key and enter the remaining numbers in the same way.
5. Scroll with the *DOWN* key until the following is displayed:

```
88psi 180°F
initialization
-> ATX3DTO <  actual initialization
- - - - -
```

6. If required, set the initialization in the same way.

### 7.8.4 Entering company data (site location)

The following information is entered in the location menu option:

- Subsidiary: name of the KAESER subsidiary (for customers with a SIGMA TELE CARE agreement this is already entered)
- Customer: name of the company
- Customer's phone: phone number with which KAESER Service can call back
- SMS language: the language of the SMS sent (select according to the KAESER Service subsidiary)



Condition: password level 4 is activated,  
the menu option configuration > SMS is selected

1. Keep on pressing the *DOWN* key until *location* appears in the third line of the display.
2. Press the *Enter* key.

```
88psi 180°F
-----
subsidiary
-> CBG
```

*name of the KAESER subsidiary*

3. Scroll down with the *DOWN* key until *customer* appears in the second line.
4. Press the *Enter* key.
5. Edit the company name with the *UP* or *DOWN* key and confirm with the *Enter* key, use the next line, if necessary
6. Enter the phone number in the menu option *tel . customer* in the same way.
7. Scroll down with the *DOWN* key until *SMS* appears in the second line.
8. Use the *DOWN* key or the *UP* key to select the SMS language and confirm by pressing *Enter*.

### 7.8.5 Configuring selection of the Service Centre (channel)

#### Overview

The preset data entered by KAESER are displayed in menu option channel 1:

- Phone number of the responsible call centre
- Phone number of the SMS message
- Selection of the SMS protocol

The following settings can be changed:

- Number of auto re-dials
- Duration of the interval between two calls

Condition: password level 4 is activated.  
the menu option configuration > SMS is selected.



Ask your network provider for the number of the call centre.

1. Keep on pressing the *DOWN* key until *channel1* appears in the third line of the display.
2. Press the *Enter* key.

```
88psi 180°F
tel. CallCenter
-> 017125
```

*CallCenter number (first digits)*

```
-> 21002
```

*CallCenter number (following digits)*

3. Scroll down with the *DOWN* key until *auto re-dial* appears in the second line.
4. Press the *Enter* key.
5. Use the *DOWN* key or the *UP* key to set as required and confirm by pressing *Enter*.
6. Set up the duration of the interval in the same way.

The same settings can be made in the channel 2 menu option.

**Saving the settings**

The settings are automatically saved in an EEPROM that is no-volt safe. The settings are still available even if the buffer battery discharges completely.

**7.9 Configuring input and output signals**

The controller's binary and analog inputs and outputs can be used for further requirements. This chapter deals with the various options in the following sections:

7.9.1: Outputting important operational machine states

7.9.2: Display of analog input values

7.9.3: Displaying additional binary input signals

7.9.4: Using machine pressure and temperature values as switches

7.9.5: Configuring analog outputs



The controller only allows assignment of spare inputs and outputs. If an occupied input or output is assigned this will be rejected by the controller (the display returns to n.a. when the *Enter* key is pressed). The outputs DO 0.3 to DO 0.5 are left as spare at the factory. Further spare outputs can be found in the machine circuit diagram.

**7.9.1 Outputting important operational states of the machine.**

Important operational machine states can be made available as a binary signal via volt-free contacts.

The following messages can be outputted:

Message	Explanation	Output
controller ON	Controller is powered up	
Group alarm	Alarm is activated	
Motor running	Motor running	
Compressor ON	The machine is switched on.	
Group warning	Warning message has appeared	
Remote mode	Remote mode is activated	
IDLE	The machine is in IDLE mode	
LOAD	The machine is in LOAD mode	
Clock active	The clock is activated	
Clock contact	The contact is closed	
Emergency stop	Emergency stop switch has been pressed	

Tab. 29 Assigned output signals

### Overview

The configuration is entered in menu option I/O periphery > DO functions:

- Enter password for level 4
- Select menu options configuration > I/O periphery > DO functions
- Assigning a message to an output

#### 7.9.1.1 Selecting menu options configuration > I/O periphery

Condition: password level 4 is activated.

1. In the main menu, keep pressing the *UP* key until *configuration* appears in the third line of the display.
2. Press the *Enter* key.
3. Keep on pressing the *DOWN* key until *I/O periphery* appears in the third line of the display.
4. Press the *Enter* key.

```
88psi 180°F
```

```
DO functions <  menu option for binary output functions
Show quantities  menu option for showing quantities
```

#### Selecting the menu option "DO functions"

5. Press the *Enter* key again.

A list of available messages and their assigned outputs is displayed.

```
88psi 180°F
```

```
controller ON  controller ON message
-> n.a. <      no output assigned
Group alarm    group alarm message
```

#### 7.9.1.2 Assigning a message to an output

6. Select the required message with the *DOWN* key.

7. Press the *Enter* key.

The cursor appears over inverse n.a. (or the assigned output).

8. Use the *DOWN* key or the *UP* key to select a spare output and confirm by pressing *Enter*.

A message is now sent via the output assigned.

9. For clarity, enter the output in the table above

### 7.9.2 Displaying analog input values

Up to six pressure, temperature, etc. values from various sensors/transducers can be displayed at display level in the analog data menu.

Of these, two are assigned to pressure transducers and two to temperature sensors; two further inputs can be assigned to freely selectable sensor types. A list of standard analog data that can be displayed is found in chapter 8.6.



**7.9.2.4 Select the type of signal (4 - 20 mA/0 - 20 mA)**

6. Press the *DOWN* key once to select the input signal.  
As 4 - 20 mA is preset, no setting is needed.

**7.9.2.5 Allocating a value range to the measurement (calibration)**

The factory setting is a range from 0 - 10.000 that represents a signal current between 4 - 20 mA. This quantity range has to be adapted to represent the measurement range of the sensor of 0 – 30 cfm.

7. Keep pressing the *DOWN* key until the following is displayed:

88psi	180°F	
calibration		
20mA:	10000 <	<i>top of the signal range</i>
4mA:	0	<i>bottom of the signal range</i>

8. Press the *Enter* key.
9. Press and hold the *DOWN* key and to set the top of the range to 50.  
The quantity reduces initially in steps of units, then tens, hundreds and finally in thousands.
10. Using this method, reduce the quantity to 100 and then set to 50 with the *DOWN* key.
11. Confirm the setting with the *Enter* key.
12. Set the bottom quantity for 4 mA in the same way.

**7.9.2.6 Editing sensor designation and unit of measure**

13. Scroll up the display to the line for sensor designation with the *UP* key.
14. Press the *Enter* key and select characters from the character set with the *UP* and *DOWN* keys to give the sensor signal a designation. There are 15 characters to choose from.
15. Confirm the entry with the *Enter* key.
16. Enter the unit of measure in the line below in the same way.

The signal value from the sensor can now be displayed in the analog data menu (see chapter 8.6).

**7.9.3 Displaying additional binary input signals**

As well as the defined alarm and warning messages there are six further freely selectable input signals that can be used to display messages. Eine Liste der definierten Störungs- und Wartungsmeldungen finden Sie in Kapitel 9. Information on spare inputs is given in the machine circuit diagram.

An input signal can be classified as either an alarm, service or operational message. To suppress any possible contact bounce or similar problems the input signal can be delayed by an adjustable period. This ensures that the signal must be apparent for a minimum period before it can be processed as a message.



If an input signal is classified as an alarm the controller goes into the alarm state and shuts down the machine.

**Overview**

The configuration is entered in menu option I/O periphery > ext.messages:

- Enter password for level 4
- Select menu options configuration > I/O periphery > ext. messages
- Selecting the message number (0 - 5)
- Selecting the message type (operational, alarm, warning)
- Assign an input
- Setting the time delay
- Entering the message text

**7.9.3.1 Selecting menu option "ext. messages"**

Condition: password level 4 is activated,  
menu option configuration > I/O periphery is selected  
(see section 7.9.1.1).

1. Keep pressing the *DOWN* key until ext. messages appears in the third line of the display.
2. Press the *Enter* key.

```

88psi 180°F
ext. message 0 < external message number 0
ext. message 1
  
```

**7.9.3.2 Selecting the message number (0-5)**

3. Use the *DOWN* key to select a spare message number and confirm with the *Enter* key.

```

88psi 180°F
Mmmmmmmmmmmmmmmmmmm line for the message text
-> warning < selected message type
-> n.a. no input assigned
  
```

**7.9.3.3 Selecting the message type (operational, alarm, warning)**

4. Press the *Enter* key again.
5. Use the *UP* key to select the message type and confirm with the *Enter* key.

**7.9.3.4 Assign an input**

6. Press the *DOWN* key twice, then press the *Enter* key.  
The cursor appears inverse over n.a.
7. Use the *UP* key to select the input concerned and confirm with the *Enter* key.

**7.9.3.5 Setting the time delay**

8. Press the *DOWN* key twice, then press the *Enter* key.  
The cursor appears inverse over the set time delay.

```

88psi 180°F
-> DI 2.0 selected input
td: 0.00s < set time delay
  
```

The period can be set between 0.01 and 600 seconds. The delay is counted down from 600 with the *DOWN* key and counted upwards from zero in 0.01 second steps with the *UP* key.

9. Press the *DOWN* key to set a long time delay.  
or  
Press the *UP* key to set a short time delay.
10. Confirm the time delay setting with the *Enter* key.

#### 7.9.3.6 Entering the message text

11. Using the *UP* key, scroll up the display to the line for the message text.
12. Press the *Enter* key and select characters from the character set with the *UP* and *DOWN* keys to enter the message text. There are 15 characters to choose from.
13. Confirm the entry with the *Enter* key.

The input signal is now available as a message.

#### 7.9.4 Using machine pressure and temperature values as switches

The pressure transducers and temperature sensors connected to the controller (both in the machine and on the user's premises) can be also be used as switches:

- If a set switching point SP is reached, a message can be triggered and/or a binary output signal set until pressure falls below the switching differential SD again.
- The message can be defined as an operational, warning or alarm message.
- A delay period can be set to suppress constant on/off switching caused by fluctuations around a switching point.

The following sensors can be used for the switching function:

- pressure transducers:
  - local pressure transducer (pNloc)
  - external pressure transducer (pNext)
  - internal pressure transducer (pi)
  - two further pressure transducers (dis1 and dis2)
- Temperature sensors
  - airend discharge temperature (ADT)
  - package discharge temperature (PDT)
  - motor temperature (mot T)
  - cooling water temperature cw T
  - two further temperature sensors (dis3 and dis4)

#### Overview

The configuration is entered in menu option I/O periphery > switch:

- Enter password for level 4
- Select menu option configuration > I/O periphery > switch
- Selecting the type of sensor
- Selecting the sensor
- Setting the switching point and switching differential
- Entering the message text
- Selecting the message type
- Set the delay period
- Assigning the switch to a binary output

**7.9.4.1 Selecting menu options configuration > I/O periphery**

Condition: password level 4 is activated  
menu option configuration > I/O periphery is selected  
(see section 7.9.1.1)

1. Keep pressing the *DOWN* key until *switch* appears in the third line of the display.
2. Press the *Enter* key.

```
88psi 180°F
p-switch
<
T switch
```

*menu option for the pressure switch*

*menu option for the temperature switch*

**7.9.4.2 Selecting the type of sensor**

3. Press *Enter* to select the pressure switch.  
or  
Press *DOWN* once to select the temperature switch. Confirm with the *Enter* key.

**7.9.4.3 Selecting the sensor**

```
88psi 180°F
p-switch
-> n.a. #####<
SP: 0.00psi
```

*pressure switch is selected*

*no switch has been selected*

*switching point*

4. Press the *Enter* key.
5. Use the *UP* key to select the required reference value and confirm with *Enter*.

**7.9.4.4 Setting the switching point and switching differential**

6. Press the *DOWN* key once and then press the *Enter* key.
7. Use the *DOWN* key or the *UP* key to set the value for the switching point as concerned and confirm by pressing *Enter*.
8. Set the switching differential in the same way.

**7.9.4.5 Entering the message text**

9. Press the *DOWN* key once and then press the *Enter* key.
10. Enter the message text by selecting characters from the character set with the *UP* and *DOWN* keys. There are 15 characters to choose from.
11. Save the text with the *Enter* key.

**7.9.4.6 Selecting the message type**

12. Press the *DOWN* key once and confirm with the *Enter* key.
13. Use the *UP* key to select the message type (operational, warning, alarm) and confirm with the *Enter* key.



#### 7.9.4.7 Set the delay period

14. Press the *DOWN* key once and confirm with the *Enter* key.

The cursor appears inverse over the set time delay.

88psi 180°F	
Operation	<i>selected message type</i>
td: 0.00s <	<i>actual time delay</i>
-> n.a.	<i>assigned output</i>

The period can be set between 0.01 and 3,600 seconds. The delay is counted down from 3,600 with the *DOWN* key and counted upwards from zero in 0.01 second steps with the *UP* key.

15. Press the *DOWN* key to set a long time delay.

or

Press the *UP* key to set a short time delay.

16. Confirm the time delay setting with the *Enter* key.

#### 7.9.4.8 Assigning the switch to a binary output

17. Press the *DOWN* key once and then confirm with the *Enter* key.

18. Press the *Enter* key.

The cursor appears over inverse n.a. (or the assigned output).

19. Use the *DOWN* key or the *UP* key to select a spare output and confirm by pressing *Enter*.

Configuration of the switch is now complete.

#### 7.9.5 Configuring analog outputs



A configurable analog output is only possible on a Sigma Control fitted with an expander card. If the machine is fitted with variable frequency drive (frequency converter) this output is possibly assigned.

Under the address AO1 the controller has provision for an analog output. An existing analog input pressure or temperature signal can be connected to this output and calibrated for further processing. The following input signals are available:

- System pressure (pN)
- Internal pressure (p<sub>i</sub>) in the oil separator
- airoend discharge temperature (ADT)
- Further signals specific to the machine are on inputs AI2 - AI8

In addition, two actual machine parameters can be connected to the output:

- Actual system pressure setpoint (p1 or p2)
- or
- Rate of increase of airoend discharge temperature dT/dt ADT

It is not necessary to calibrate these parameters.

##### Overview

The configuration is entered in menu option I/O periphery > AO parameter:

- Enter password for level 4
- Select menu options configuration > I/O periphery > AO parameter
- Selecting the analog input signal
- Select the type of signal (4 - 20 mA/0 - 20 mA)
- Assign the quantity range (calibration, if required)

**7.9.5.1 Selecting "AO parameter"**

Condition: password level 4 is activated,  
menu option configuration > I/O periphery is selected  
(see section 7.9.1.1).

1. Keep pressing the *DOWN* key until AO parameter appears in the third line of the display.
2. Press the *Enter* key.

88psi 180°F	
AO1 -> n.a.	<i>no signal set</i>
-> 4 -20mA	<i>set signal type</i>
<	
0.0mA	<i>actual value</i>

**7.9.5.2 Selecting the analog input signal**

3. Press the *UP* key once, to scroll n.a. into the third line of the display and then press the *Enter* key.  
The cursor appears inverse over n.a.
4. Use the *UP* key to select required input and confirm with the *Enter* key.

**7.9.5.3 Defining the type of analog signal (4-20 mA/0-20 mA)**

If the sensor concerned has a signal range of 4 - 20 mA then move on to the next instruction.

5. To alter the signal range press the *DOWN* key once and confirm with the *Enter* key.
6. Use the *UP* key to change the value to 0 - 20 mA and confirm with *Enter*.

**7.9.5.4 Allocating a value range to the measurement (calibration)**

The following steps are dependent on the analog signal to be sent.

- Actual setpoint values for the machine: no settings required
- Input signal of a temperature sensor: see calibrating a temperature sensor
- Input signal of a pressure transducer: see calibrating a pressure transducer

**Calibrating a temperature sensor**

For (0) 4 - 20 mA signals a range of 32 °F - 248 °F has been set at the factory. If the sensor covers another temperature range then it must be calibrated.

7. Keep pressing the *DOWN* key until the following is displayed:

88psi 180°F	
.	Pt100
20mA: 248°F <	<i>maximum value</i>
4mA: 32°F	<i>minimum value</i>

8. Press the *Enter* key to set the upper value.
9. Press and hold the *DOWN* key or the *UP* key to set the maximum value and confirm by pressing *Enter*.
10. Set the minimum value in the same way.

**Calibrating the pressure range**

For 0 - 20 mA or 4 - 20 mA signals a range of 0 - 230 psi has been set at the factory. If the sensor covers another pressure range then it must be calibrated.

11. Keep pressing the *DOWN* key until the following is displayed:

```
88psi 180°F
      p1(2)
20mA: 230 psi <  maximum value
4mA:  0.0 psi   minimum value
```

12. Press the *Enter* key to set the upper value.

13. Press and hold the *DOWN* key or the *UP* key to set the maximum value and confirm by pressing *Enter*.

14. Set the minimum value in the same way.

Configuration of the outputs is now complete.

**7.10 Configuring the Package Discharge Air Temperature**

In order to monitor the air discharge temperature from the compressor, e.g. downstream of the air cooler, an appropriate sensor (PT100) must be installed there. Further information is given in the circuit diagram.

**7.10.1 Compensating line resistance**

To compensate for the increased line resistance of the temperature sensor caused by long cable runs it is possible to correct (reduce) the temperature value displayed.

**Overview**

The correction can be made in the menu option components> PD temperature

- Enter password for level 4
- Select menu option components > PD temperature
- Entering the correction value

**7.10.1.1 Select menu option components > PD temperature**

Condition: password level 4 is activated.

1. In the main menu, keep pressing the *UP* key until *components* appears in the third line of the display.
2. Press the *Enter* key.
3. Keep pressing the *DOWN* key until *PD temperature* appears in the third line of the display.
4. Press the *Enter* key.

```
88psi 180°F
PD temperature
-> AI8 130°F <  actual analog input temperature
corr. -0.5°F    compensation for line resistance
```

### 7.10.2 Entering the correction value

5. Keep pressing the *DOWN* key until *corr. -0.7* appears in the third line of the display.
6. Press the *Enter* key.  
A cursor appears inverse over the temperature value.
7. Select the correction value with the *UP* key or *DOWN* key and confirm with *Enter*.  
The package discharge temperature is compensated by the correction value.

### 7.10.3 Switching levels for the package discharge temperature

The package discharge temperature is monitored at five levels:

- Minimum temperature – alarm message
- Low temperature – warning message
- Normal temperature – no message
- High temperature – warning message
- Maximum temperature – alarm message

The temperatures for these monitoring levels can be set. Likewise the analog input to which the temperature sensor is connected.

A delay period can be set to suppress constant on/off switching caused by fluctuations around a switching point.

#### Overview

The configuration can be carried out in the menu option components > PD temperature

- Enter password for level 4
- Select menu option components > PD temperature
- Select the analog input, if necessary
- Set the switching points and switching differentials for the five temperature levels
- Set the delay period

#### 7.10.3.1 Selecting the analog input

Condition: password level 4 is activated  
menu option components > PD temperature is selected  
(see section 7.10.1.1).

If an input has already been assigned, this section can be skipped.

```
88psi 180°F
PD temperature
-> AI8 130°F < actual analog input temperature
corr. -0.5°F compensation for line resistance
```

1. Press the *Enter* key.  
The cursor appears over inverse n.a. (or the assigned input).
2. Use the *DOWN* key or the *UP* key to select a spare input and confirm by pressing *Enter*.

### 7.10.3.2 Setting the switching point and switching differential

3. Keep pressing the *DOWN* key until the following is displayed:

```
88psi 180°F
. . .
| -> SP: 180°F < maximum-temperature
| -> SP: 158°F high temperature
```

4. Press the *Enter* key.
5. Select the correction value with the *UP* key or *DOWN* key and confirm with *Enter*.
6. Set the high, low and minimum temperatures in the same way.

### 7.10.3.3 Set the delay period

7. Keep on pressing the *DOWN* key until *td: 0.00s* appears in the third line of the display.
8. Press the *Enter* key.

The cursor appears inverse over the set time delay.

```
6.1bar 80°C
. . .
td: 0.00s < actual time delay
```

The delay can be set between 0.01 and 300 seconds. The delay is counted down from 300 with the *DOWN* key and counted upwards from zero in 0.01 second steps with the *UP* key.

9. Press the *DOWN* key to set a long time delay.  
or  
Press the *UP* key to set a short time delay.
10. Confirm the time delay setting with the *Enter* key.

The settings for package discharge temperature monitoring are now configured.

## 7.11 Activating Remote Reset

When warning or alarm messages are routed to a remote control centre via an output it makes sense to have these messages acknowledged and reset by the control centre.

To allow this, the remote reset and remote key have to be activated. In addition, a controller input must be assigned to the reset signal.

### Overview

- Enter password for level 4
- Selecting menu option configuration > acknowledgement
- Setting the remote reset function
- Activating the remote key
- Assign an input
- Press remote key

### 7.11.1 Selecting menu option configuration > acknowledgement

Condition: password level 4 is activated.

1. In the main menu, keep pressing the *UP* key until *configuration* appears in the third line of the display.

2. Press the *Enter* key.
3. Keep pressing the *DOWN* key until acknowledgement appears in the third line of the display.
4. Press the *Enter* key.

```

      88psi  180°F
remote mode
-> key      <  acknowledgement (reset) by key only
remote key: n  remote key deactivated

```

#### 7.11.2 Setting the remote reset function

5. Press the *Enter* key.
6. Press the *UP* key.  
key+RC appears in the display.
7. Press the *Enter* key to accept the setting.

#### 7.11.3 Activating the remote key

8. Press the *DOWN* key once.
9. Press the *Enter* key.  
The cursor appears over the *y* (active) or *n* (inactive).
10. Use the *UP* key or *DOWN* key to select *y* and confirm with *Enter*.  
The remote is now activated.

#### 7.11.4 Assign an input

11. Keep pressing the *DOWN* key until the following is displayed:

```

      88psi  180°F
- - - - -
RC      -> n.a. <  no remote contact input has been assigned

```

12. Press the *Enter* key.  
The cursor appears inverse over n.a.
13. Use the *UP* key to select the required input and confirm with the *Enter* key.  
The input has now been assigned.
14. Press the *remote* key to enable remote reset (acknowledgement).  
Should a warning message occur, it can now be acknowledged from a control centre.

### 7.12 Linking to an external pressure transducer

If the air system is operated with an air receiver, the pressure in the receiver can be regulated by an external pressure transducer.

The sensor output can be linked in the following ways:

- via a Profibus link (from a master controller). An input does not have to be assigned
- via the USS protocol (from a pressure transducer linked to the frequency converter), assigned to input FC USS
- via a pressure transducer (0/4–20mA) linked to Sigma Control. Assignment to the analog input is necessary.

The controller processes the options in the following sequence:

1. Profibus value,
2. Pressure according to the assigned external transducer,
3. Local system pressure, the local system pressure transducer remains activated.

#### **Overview**

- Enter password for level 4
- Select menu option configuration > pressure settings > press.act.value
- Assign an input
- Select the type of analog signal (4 - 20 mA/0 - 20 mA), if necessary

#### **7.12.1 Selecting menu option configuration > pressure settings > load control**

Condition: password level 4 is activated.

1. In the main menu, keep pressing the *UP* key until *configuration* appears in the third line of the display.
2. Press the *Enter* key.  
*press. settings* appears in the third line of the display.
3. Press the *Enter* key again.
4. Keep pressing the *DOWN* key until *press.act.value* appears in the third line of the display.
5. Press the *Enter* key.

```
88psi 180°F
Press.act.value
->pNloc 88psi < local transducer
->4-20mA
```

#### **7.12.2 Assign an input**

6. Press the *Enter* key again.
7. A cursor appears over *pNloc*.
8. Select the input with the *UP* key or the *DOWN* key. For pressures measured via the frequency controller select *FC USS*.
9. Confirm with the *Enter* key.

The input for the external transducer is now activated. If the transducer has a signal range of 4 - 20 mA or is linked via *USS*, the configuration is complete.

#### **7.12.3 Defining the type of analog signal (4 - 20 mA/0 - 20 mA)**

10. To alter the signal range press the *DOWN* key once and confirm with the *Enter* key.
11. Use the *DOWN* key to change the value to 0 - 20 mA and confirm with *Enter*.

#### **7.13 Setting up the timer for condensate drainage**

A solenoid valve can be activated at regular intervals for the drainage of condensate.

#### **Overview**

- Enter password for level 4
- Selecting menu option configuration > timer
- Setting the timer OFF and timer ON periods
- Assigning an output to the solenoid valve

### 7.13.1 Selecting menu option configuration > timer

Condition: password level 4 is activated.

1. In the main menu, keep pressing the *UP* key until *configuration* appears in the third line of the display.
2. Press the *Enter* key.  
press. settings appears in the third line of the display.
3. Keep pressing the *DOWN* key until *timer* appears in the third line of the display.
4. Press the *Enter* key.

88psi	180°F	
Timer		<i>timer menu option</i>
OFF	300s <	<i>timer off period of 300 seconds</i>
ON	5.00	<i>timer on period of 5 seconds</i>

### 7.13.2 Setting the timer OFF and timer ON periods

5. To change the timer OFF period, press the *DOWN* key once and confirm with the *Enter* key.  
The cursor appears inverse over the set time delay. The period can be set between 0.01 and 3600 seconds.
6. Change the OFF period with the *DOWN* or *UP* keys.
7. Confirm the setting with the *Enter* key.
8. Set the ON period for the drain valve in the same way.

### 7.13.3 Assigning an output to the solenoid valve

9. Press the *DOWN* key once and confirm with the *Enter* key.  
The cursor appears inverse over n.a.
10. Use the *UP* key to select the required output and confirm with the *Enter* key.  
The timer is now configured.

## 7.14 Activating the energy–saving mode for the refrigeration dryer

Continuous or timer modes can be activated for control of the refrigeration dryer. Using the menu option "timer" the dryer can be shut down under time control whenever no compressed air is required.

The operating temperature in the refrigeration dryer is kept constant within narrow limits under this method of control by cycling the refrigerant circulation.

Condition: password level 4 is activated

1. In the main menu, keep pressing the *UP* key until *configuration* appears in the third line of the display.
2. Keep pressing the *DOWN* key until *control mode* appears in the third line of the display.
3. Press the *Enter* key.

88psi	180°F	
local mode		<i>actual operating mode</i>
-> Dual	<	
Control mode		



- Keep pressing the *DOWN* key until the following is displayed:

```

88psi 180°F
dryer
-> Continuous < continuous mode is activated
. . .
    
```

- Press the *Enter* key.  
A cursor appears inverse over the mode.
- Set the required control mode with the *UP* or *DOWN* keys.
- Press the *Enter* key to accept the operating mode.
- Press the *Escape* key as often as necessary to return to the main menu.

### 7.15 Initial Start-up

- ▶ Before initial startup, check that the conditions listed in the service manual have been met.

	Checking the controller settings	Section	Done?
1	▶ Language correctly set	7.1.2	
2	▶ Date and time correct	7.1.4	
3	▶ Display format correctly set	7.1.5	
4	▶ System pressure setpoint correctly set	7.2	

Tab. 30 Checklist of installation conditions

- ▶ Check and confirm all the items in the checklist before starting the machine.  
When power is applied to the machine the controller boots and carries out a self test. The display illuminates and power LED (8) lights up.  
The actual system pressure and the airend discharge temperature are displayed in the first line of the display.

```

88psi 120°F system pressure and airend discharge pressure
- - - - -
off
- - - - -
    
```

- ▶ Press the *LOAD/IDLE* toggle key (13).



**CAUTION**

**Too short a start period**

Too short a start period can damage the machine.

- ▶ Press the *ON* key and let the machine run for at least one minute in *IDLE*, to allow sufficient oil to enter the pressure system.
- ▶ Press the *LOAD/IDLE* toggle key.  
The machine switches to the *LOAD* state and delivers compressed air.

## 8 Operation

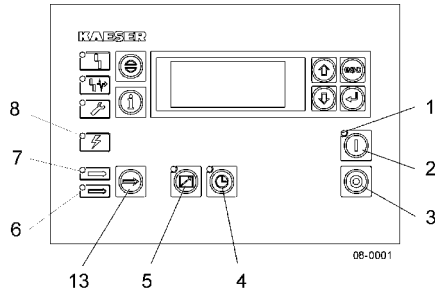

Fig. 10 Switching On and Off

- |   |                          |    |                        |
|---|--------------------------|----|------------------------|
| 1 | "Machine ON" LED (green) | 6  | "LOAD" LED             |
| 2 | ON key                   | 7  | "IDLE" LED             |
| 3 | OFF key                  | 8  | 'Power ON' LED (green) |
| 4 | Clock key                | 13 | Idlekey                |
| 5 | Remote key               |    |                        |

### 8.1 Switching the Machine On and Off

#### 8.1.1 Switching on the machine in local mode



**Damage can occur by switching on and off too frequently.**

**CAUTION**

- ▶ Take the permissible motor switching frequency into account when switching the machine on and off.

Further instructions with regard to switching on and off correctly:

1. Do not switch the compressor on and off with the main disconnect switch.
2. Always switch the machine on with the *ON* key and off with the *OFF* key.

#### Ensuring operational readiness

- ▶ Before switching on, make sure that
  - nobody is working on the machine,
  - all panels are in place.
  - the access doors are closed,
  - the machine has warmed up to at least 40 ° F.

#### Switching on the machine



**Compressed air can cause injury!**

**CAUTION**

- ▶ Ensure operational readiness

1. Switch on the main switch/supply disconnecting device.  
The controller carries out a self-test and the green LED 'Power ON' (8) lights.
2. Press the *ON* key (2).  
The green 'Machine ON' LED lights (1).  
The compressor motor runs up as soon as the network pressure is lower than the system pressure setpoint.

**Automatic restart**

The automatic restart is activated at the factory. If the actual system pressure is lower than the system pressure setpoint, the machine starts automatically after a power failure. see chapter 7.3.5 for instructions on deactivating automatic restart.

**Automatic starting!**

There is danger of injury from the machine starting automatically or by remote start command.

- ▶ Isolate the machine from the mains and lock out all phases of the power supply before opening any machine enclosure or guard.



If the Machine ON LED (1) is lit, but not the LOAD (6) and IDLE (7) LEDs, the machine is at a standstill and ready to start. The machine can start at any moment.

**8.1.2 Switching off the machine in local mode**

1. Press the *Idle* key (13).  
The machine switches to IDLE and the LED (7) flashes.
2. After running in idle for 20 seconds, press the *OFF* key (3).  
The "Machine ON" LED goes out (1).
3. Switch off and lock out the main disconnect switch.

**Switching off in an emergency**

- ▶ Press the EMERGENCY STOP key.  
The EMERGENCY STOP pushbutton remains latched in.  
The compressor is vented and the machine is prevented from re-starting.

**Starting again after an emergency stop**

1. Turn the EMERGENCY STOP button in the direction of the arrow to unlatch it.
2. Press the Reset key to delete any existing alarm messages.
3. Switch on the machine.

**8.1.3 Remote on and off switching**

Condition: a remote control centre is connected.

- ▶ Press the *remote* key (5).  
The LED (5) lights up. The machine can now be controlled from a remote control centre.

The machine can still be switched on and off by the *ON* (2) or *OFF* (3) keys, if required.

**8.1.4 Switching on and off with the clock**

Condition: the clock program is entered,  
the *clock* key is activated.

- ▶ Press the *Clock* key (4).  
The LED (4) lights up. The clock now has control of the machine.

## 8.2 Resetting alarm messages

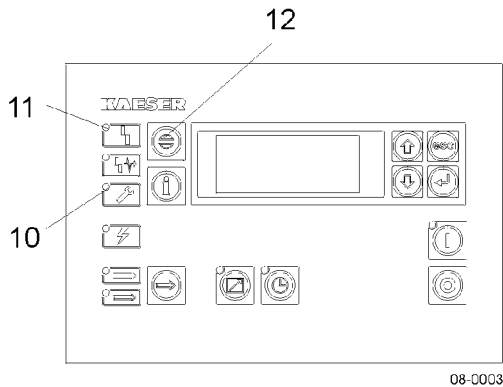

Fig. 11 Resetting warning and alarm messages

- 10 "Warning" LED (yellow)
- 11 "Alarm" LED (red)
- 12 Reset key

An alarm shuts the machine down automatically. The red 'Alarm' LED blinks (11).

The last line in the display shows the actual fault causing the alarm. A table of possible alarms occurring during operation are shown in section 9.1.

Condition: the fault has been removed

- ▶ Press the *Reset* key (12).  
The alarm LED goes out (11).  
The machine is ready for operation again.



If the machine has been shut down with the EMERGENCY STOP pushbutton:

- ▶ Unlatch the EMERGENCY STOP pushbutton before pressing the reset key (turn the pushbutton in the direction of the arrow).

### 8.3 Resetting warning messages

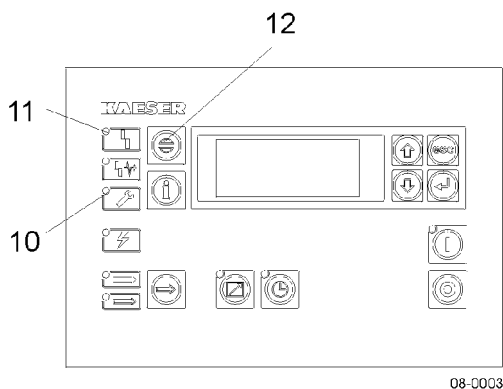

Fig. 12 Resetting warning and alarm messages

- 10 "Warning" LED (yellow)
- 11 "Alarm" LED (red)
- 12 Reset key

If maintenance work is to be carried out or if the warning is displayed before an alarm, the yellow "Warning" LED (10) flashes.

The last line in the display shows the actual warning.

A table of possible warning messages is shown in section 9.2.

Condition: the threat of an alarm is removed,  
maintenance task has been completed.

- ▶ Reset the warning message with the *Reset* key (12).  
The warning LED (10) goes out.

### 8.4 Displaying the Actual Operating Mode

- ▶ To display the actual operating mode, press the *DOWN* key once.

Example	Explanation
<pre> 88psi 180°F idle ----- FC-on p1-idle                     </pre>	<p><i>remote contact, switched on, system pressure setpoint p1, idling</i></p>

The operating modes are shown using the following abbreviations:

e.g. key-on | p1-idle

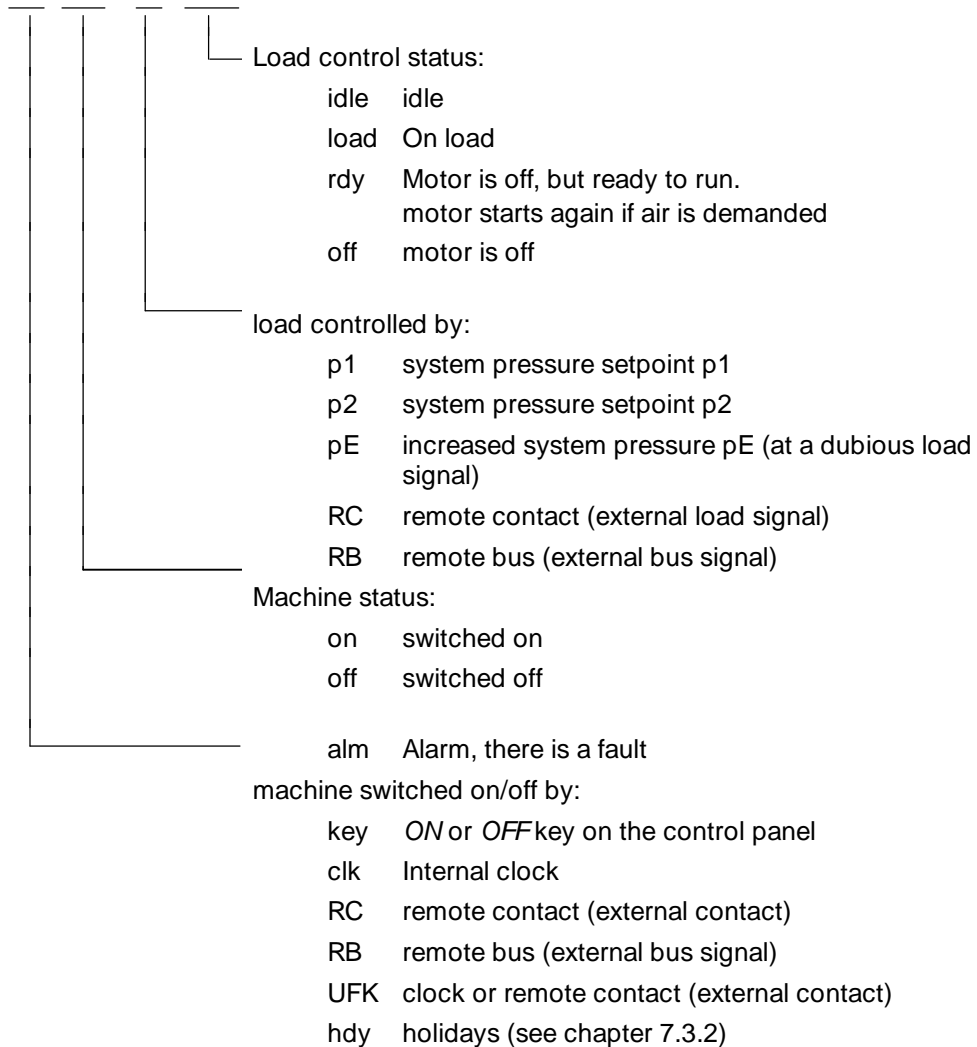

## 8.5 Setting up Machine Pressure

A detailed explanation of all pressure parameter settings is given in chapter 7.2.

## 8.6 Displaying Messages

The following information can be called up in the status > messages menu option:

- Event memory record of the last 100 events, these include alarm and warning messages
- Last alarm
- Last warning
- Number of actual alarms

**List of displayable information in a message**

The information in a message is shown in three lines of the display. Message type and status are shown abbreviated.

Example:

```

      88psi  180°F
W  a  16:10:31  warning message occurred at...
      23.07.2004  on...
no pressure  message text
build-up

```

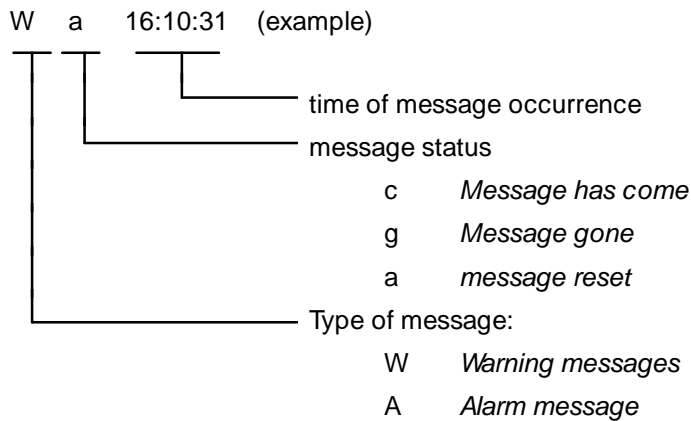

**8.6.1 Selecting menu option status > messages**

1. In the main menu keep on pressing the *DOWN* key until *status* appears in the third line of the display.
2. Press the *Enter* key.  
messages appears in the display.
3. Press the *Enter* key.  
event info appears in the display.

**Displaying event information**

4. Press the *Enter* key.  
The last message (event) displayed appears in the display. The messages are displayed chronologically.
5. Scroll through past events with the *DOWN* key and back to actual events again with the *UP* key.
6. Press the *Escape* key as often as necessary to return to the main menu.

**Displaying the last alarm**

Condition: menu option status > messages is selected

1. Keep on pressing the *DOWN* key until *last alarm:* appears in the third line of the display.
2. Press the *Enter* key.  
The last alarm is displayed.

3. Press the *Escape* key as often as necessary to return to the main menu.

#### Displaying the last warning

Condition: menu option status > messages is selected

1. Keep on pressing the *DOWN* key until `last warning:` appears in the third line of the display.
2. Press the *Enter* key.  
The last warning is displayed.
3. Press the *Escape* key as often as necessary to return to the main menu.

#### Displaying the number of current alarms or warnings

Condition: menu option status > messages is selected

1. Keep on pressing the *DOWN* key until the number of alarms and warnings present appears.
2. Press the *Escape* key as often as necessary to return to the main menu.

### 8.7 Displaying status data, resetting and printing

The following information can be called up in the status > statistics menu option:

- Machine duty cycle (relationship between load hours and overall operating hours) as a percentage and from a defined day.
- Max. and min. system pressure and max. internal pressure
- Motor starts as from a defined day and the total number of motor starts
- Motor starts per day and per hour
- Last run under load, last run in idle, last motor stop

The status data can be displayed with the *DOWN* and *UP* keys.

#### Resetting status data

Some status data can be reset. The value displayed is deleted and evaluated anew from the time of the reset. These are:

- Motor starts as from a defined day
- Max. and min. system pressure and max. internal pressure
- Motor starts from a defined day onwards

#### 8.7.1 Displaying and resetting machine duty cycle

1. In the main menu keep on pressing the *DOWN* key until `status` appears in the third line of the display.
2. Press the *Enter* key.
3. Press the *DOWN* key once.
4. Press the *Enter* key.

Status data are displayed, starting with machine duty cycle.

88psi 180°F	
Duty cycle	
* total	<i>duty cycle as from initial start-up</i>
85.2%	
SFC RS485###%	<i>duty cycle for SFC</i>



**Resetting**

Condition: password level 4 is activated.

1. Keep on pressing the *DOWN* key until `reset : n` appears in the third line of the display.
2. Press the *Enter* key.  
The cursor appears inverse over `n`
3. Use the *UP* key to select `y` and confirm with *Enter*.  
The actual date is taken as the starting date. The duty cycle is evaluated as from the new starting date.
4. Press the *Escape* key as often as necessary to return to the main menu.

**8.7.2 Displaying and resetting further status data**

1. In menu option `status > statistics`, press the *DOWN* key to display the following status data:

Duty cycle from a defined day onwards

system pressure

- max: maximum system pressure since last reset
- min: minimum system pressure since the last reset

internal pressure

- max: maximum internal pressure since last reset

motor starts

- total number of motor starts
- number of motor starts since last reset

motor starts /d

- max. `___` : permissible motor starts per day (this is specific to the machine)
- number of detected starts over the last 24 hours

motor starts /h

- max. `___` : permissible motor starts per hour (this is specific to the machine)
- number of detected starts over the last 60 minutes

motor starts T

- number of detected motor starts below the minimum temperature

last load run

- date and time of the last changeover from LOAD to IDLE mode

last idle run

- date and time of the last changeover from IDLE to LOAD mode

motor OFF

- date and time of the last shutdown  
or the last changeover from IDLE mode to operational

2. Proceed as detailed in the previous section to carry out a reset.
3. Press the *Escape* key as often as necessary to return to the main menu.

**8.7.3 Changing the permissible number of motor starts**

Condition: password level 4 is activated.

The number of motor starts can be changed, e.g. in the case of an exchanged motor.

1. In menu option status > statistics keep pressing the *DOWN* key until *motor starts* appears in the third line of the display.
2. Press the *Enter* key.  
The cursor appears inverse over the *total* number:
3. Use the *DOWN* key or the *UP* key to set the new value and confirm by pressing *Enter*.
4. Press the *Escape* key as often as necessary to return to the main menu.

#### 8.7.4 Transferring event memory data or parameter data to a PC

Condition: password level 4 is activated,  
the interface is configured and  
a PC is connected to the serial interface.

A condition for transfer of data is an online PC. Setting up the interface is described in chapter 7.7.

1. In the main menu, keep pressing the *UP* key until *communication* appears in the third line of the display.
2. Press the *Enter* key.
3. Keep pressing the *DOWN* key until *data>PC* appears in the third line of the display.
4. Press the *Enter* key.
5. Press the *DOWN* key or *UP* key until *event info* or *data* appears in the third line of the display.
6. Press the *Enter* key.  
The data transfer starts. When the transfer is completed, the display changes back to n. a. (not active).

### 8.8 Displaying analog data

The following information can be called up in the analog menu option:

Information
actual system pressure local ( pN loc )
actual system pressure external ( pN ext )*
actual internal pressure ( pi )*
actual cut-out pressure ( p1 or p2) SP and SD
pressure differential across oil filter ( dp )*
airend discharge temperature (ADT)
airend discharge temperature before start
rate of rise of airend discharge temperature (dT/dt)
package discharge temperature*
variable frequency drive speed
analog output*
pressure differential across air filter dp*

\* optional or according to compressor model

The data for actual pressure can be displayed in the configuration > press. settings > press.act.value menu option.

<b>Information</b>
cooling water temperature*
motor temperature*
pressure differential across oil filter dp*

\* optional or according to compressor model

The data for actual pressure can be displayed in the configuration > press. settings > press.act.value menu option.

Tab. 31 *Displayed analog data*

### Displaying analog data

Condition: password level 4 is activated.

1. In the main menu keep on pressing the *DOWN* key until *analog* data appears in the third line of the display.
2. Press the *Enter* key.

All the compressor's analog data are displayed.  
(example):

```

88psi 180°F
system pressure
pNloc 94psi      local system pressure
. . .

```

3. Scroll with the *DOWN* key to display further analog data.
4. Scroll with the *UP* key to display own analog data.
5. Press the *Escape* key as often as necessary to return to the main menu.

## 8.9 Displaying operating data

The following information can be called up in the operating data menu option:

- Operating hours
  - compressor run: total machine running hours
  - on load: machine on load running time
  - motor: motor running time (can be changed)
  - airend: airend running time (can be changed)
  - Sigma Control: controller's hours of operation
  - mod. valve: modulating valve's operational hours
- Load valve ON frequency
- Machine power consumption (according to type)

### Displaying operating data

1. In the main menu keep pressing the *DOWN* key until *operating* data appears in the third line of the display.
2. Press the *Enter* key.  
*operating hours* appears in the display.
3. Press the *Enter* key to display machine operating hours  
or

scroll down with the *DOWN* key to display the load valve ON frequency and the power consumption of the machine.

### **Changing the operating hours**

The motor and airend running times can be changed, e.g. in the case of an exchanged motor.

Condition: password level 4 is activated.

1. In the main menu keep pressing the *DOWN* key until *operating* data appears in the third line of the display.
2. Press the *Enter* key.  
*operating hours* appears in the display.
3. Press the *Enter* key.
4. Press the *DOWN* key until motor (or airend) appears in the second line of the display.
5. Press the *Enter* key.
6. Use the *DOWN* key or the *UP* key to set the required value and confirm by pressing *Enter*.
7. Press the *Escape* key as often as necessary to return to the main menu.

## **8.10 Resetting maintenance interval hours counters**

Maintenance interval counters register the operating hours between maintenance tasks. The remaining hours in the respective maintenance interval counter can be individually reset.

The controller registers the maintenance intervals for the following components:

- Oil filter and oil separator
- Oil change
- Air filter
- Belt change (blt.coup.chng.) and belt tension (blt.coup.insp.)
- Coupling change (blt.coup.chng.) and coupling inspection (blt.coup.insp.)
- Bearing change and bearing maintenance
- Electrical equipment

### **Overview**

Proceed as follows to reset a maintenance interval counter:

- If not activated, enter password for level 4
- Selecting menu option *maintenance > maintenance interval hours counter*
- Resetting maintenance interval hours counters

Condition: maintenance task has been completed,  
service message is reset,  
password level 4 is activated.

### **Selecting menu option *maintenance > maintenance interval hours counter***

1. In the main menu, keep pressing the *DOWN* key until *maintenance* appears in the third line of the display.

2. Press the *Enter* key.

A maintenance interval hours counter (e.g. oil filter) appears.

88psi 180°F	
Oil filter	<i>name of the maintenance interval hours counter</i>
6000h   0150h <	<i>preset interval / remaining hours to maintenance</i>
reset: n	

3. Keep pressing the *UP* or *DOWN* key until the unit to be maintained appears in the second line of the display.

#### Resetting maintenance interval hours counters

4. Press the *DOWN* key.

5. Press the *Enter* key.

The cursor appears inverse over `reset: n`.

6. Use the *UP* key to select `y` and confirm with *Enter*.

The remaining interval hours now change to the total hours of the maintenance interval, the reset parameter changes from `y` to `n`.

7. Press the *Escape* key as often as necessary to return to the main menu.

## 8.11 Setting the maintenance interval

### Overview

Proceed as follows to set a maintenance interval:

- If not activated, enter password for level 4
- Selecting menu option `maintenance > maintenance interval hours counter`
- Changing the maintenance interval

Condition: password level 4 is activated

### Selecting menu option `maintenance > maintenance interval hours counter`

1. In the main menu, keep on pressing the *DOWN* key until `maintenance` appears in the third line of the display.
2. Press the *Enter* key.
3. A maintenance interval hours counter (e.g. oil filter) appears.

88psi 180°F	
Oil filter	<i>name of the maintenance interval hours counter</i>
6000h   0150h <	<i>preset interval / remaining hours to maintenance</i>
reset: n	

4. Keep pressing the *UP* or *DOWN* key until the unit appears in the second line of the display.

### Changing the maintenance interval

5. Press the *Enter* key.

The cursor appears over the preset maintenance interval.

6. Press the *UP* or *DOWN* key to change the interval hour by hour.  
or  
Press and hold the *UP* or *DOWN* key to change the interval by tens, hundreds or thousands of hours.
7. Confirm with the *Enter* key.
8. Press the *Escape* key as often as necessary to return to the main menu.

### 8.12 Resetting annual maintenance messages

The annual maintenance message serves as a reminder of maintenance work and is not related to actual machine operating hours.

The controller stores the actual data (time stamp) 100 hours after initial start up of the machine. If no maintenance has been carried out by the same date the following year or none of the following maintenance interval counters have been reset, the message "annual maint" appears.

- Oil filter
  - Oil separator
  - Oil change
  - Air filter
- To reset the message, proceed as described in chapter 8.10.  
The controller stores the actual date and starts the next annual interval.

### 8.13 Checking the safety relief valve



This check may only be carried out

- by persons trained on the machine/controller and persons instructed by and under the supervision of a specialist
- by specialists
- by authorised KAESER service personnel.

#### Overview

- Preparation for the test
- Carrying out the check
- Correct conclusion of the test



When check mode "safety relief valve" is activated, monitoring of internal pressure (blowoff protection) and regulation of the system pressure at the setpoint is deactivated.



#### **Danger of injury from pressurised components**

#### **CAUTION**

- The instructions listed below must be followed without fail.

#### **Preparation for the test**

1. Note the opening pressure (or activating pressure) of the safety relief valve from the machine's nameplate.

2. Press the *OFF* key to shut down the machine.
3. Close the shut-off valve supplying the air main network from the machine.
4. Activate password level 4 in the controller (see section 7.1.3).
5. In the main menu, keep pressing the *UP* key until `package test` appears in the third line of the display.
6. Press the *Enter* key.  
TÜV check appears in the display.
7. Press the *Enter* key.

```

88psi 180°F
TÜV check
relief valve: n<
pRV: 230 psi
    
```

*activating pressure of safety relief valve (example)*

8. Press the *Enter* key.  
The cursor appears over `relief valve: n`.

#### Carrying out the check

9. Use the *UP* key to select `y` and confirm with *Enter*.  
The "safety relief valve" check mode is activated. Monitoring of internal pressure and system setpoint pressure is deactivated!
10. Press the *DOWN* key once to display the internal pressure:

```

88psi 180°F
relief valve: y
pRV: 230 psi
pi: 106 psi
    
```

*activating pressure of the safety relief valve*  
*actual internal pressure*

11. Press and hold the *ON* key.  
The machine switches to load, the internal pressure `pi` of the machine rises.
12. Keep an eye on the rise in `pi` on the display as long as the check is running.
13. If `pi` increases to more than 10 % of the opening pressure of the safety relief valve shut down the machine with the *OFF* key and change the valve.



Avoid oil mist:

- ▶ Release the *ON* key as soon as the safety relief valve opens to keep build-up of oil mist as low as possible.



If the `pRV^` alarm appears in the display, the safety relief valve is defective. The permissible internal pressure was exceeded by 2 bar.

- ▶ Have the safety relief valve replaced by an authorized KAESER Service agent.

#### Correct conclusion of the test

14. Press the *UP* key once.

15. Press the *Enter* key.

The cursor appears over relief valve: *y*.

16. Use the *DOWN* key to select *n* and confirm with *Enter*.

The "safety relief valve" check mode is de-activated and the test ended.

17. Press the *Escape* key as often as necessary to return to the main menu.

18. Open the shut-off valve from the machine again.

The machine is ready for operation.

## 8.14 Checking the Temperature Sensor and Overtemperature Shutdown Function



This check may only be carried out

- by persons trained on the machine/controller and persons instructed by and under the supervision of a specialist
- by specialists
- by an authorised KAESER service agent.

The machine should shut down if the airend discharge temperature reaches a maximum of 230 ° F. A higher temperature is simulated to check this function. This is necessary to evaluate and enter an offset value.

During the check mode this offset is added to the actual temperature to cause the machine to shut down prematurely.

### Overview

- Ascertain and enter the offset
- Shut down the machine and allow to cool down slightly
- Carrying out the check
- Correct conclusion of the test

### Ascertaining offset

1. Read off the airend discharge temperature under load (normal working temperature) (first line in the display, e.g.: 180 ° F)
2. Offset = 230 ° F minus the airend discharge temperature (offset in this case = 50 ° F)
3. Shut down the machine with the *OFF* key
4. Watch the first line of the display and wait until the airend discharge temperature has dropped by about 6 ° F.

### Setting the offset

5. Activate password level 4 in the controller (see section 7.1.3).
6. In the main menu, keep pressing the *UP* key until *package test* appears in the third line of the display.
7. Press the *Enter* key.  
"TÜV inspection" appears in the display.



8. Keep pressing the *DOWN* key until the following is displayed:

```
88psi 180°F
ADT alarm: n
offset = 40 °F<  offset value set (example)
ADT ^ : 0 °F
```

9. Press the *Enter* key.

The cursor appears inverse over *offset*: 40\_ °F.

10. Use the *DOWN* key or the *UP* key to enter the calculated offset and confirm by pressing *Enter*.

### Carrying out the check

Condition: machine has cooled down by about 6 ° F

11. Press the *UP* key once so that *ADT alarm: n* appears in the third line of the display.

12. Press the *Enter* key.

The cursor appears inverse over *ADT alarm: n*.

13. Use the *UP* key to select *y* and confirm with *Enter*.

The "overtemperature shutdown" check mode is activated.

14. Press the *DOWN* key once to display the operating temperature + offset:

```
88psi 163°F  reduced operating temperature (163 °F)
ADT alarm: y  overtemperature shutdown
offset = 50 °F<  offset value set (example)
ADT ^: 213 °F  operating temperature + offset
```

15. Press the *ON* key to switch the machine to *LOAD*.

The machine goes on load and the airend discharge temperature rises to the operating temperature again.

As soon as a VET temperature of 230 ° F is reached, the machine shuts down and an alarm is activated.



If the machine does not shut down:

- ▶ Abort the check and contact KAESER Service as soon as possible.

### Correct conclusion of the test

16. Press the *Enter* key.

17. Reset the offset to 40 ° F and confirm with *Enter*.

18. Press the *UP* key once so that *ADT alarm: y* appears in the third line of the display.

19. Press the *Enter* key.

20. Use the *UP* key to select *n* and confirm with *Enter*.

The "overtemperature shutdown" check mode is de-activated and the test ended.

21. Press the *Escape* key as often as necessary to return to the main menu.

**8.15 Determining the optimal control mode.**

Depending on the application, one of the three control modes, DUAL, VARIO or QUADRO can be selected for the most economical duty cycle (relationship between hours on load to total operating hours).

1. Enter password for level 4
2. Reset the "duty cycle" setting in the statistics menu option (see section 8.7)
3. select a control mode in the "configuration" menu option (see section 7.4)
4. Run the machine for an extended period (approx. one month or longer).
5. Note the "duty cycle" value and then reset again.
6. Select another control mode.
7. Compare results after running the machine for the same period.
8. Repeat the procedure for the third control mode.
9. Select the control mode with the highest duty cycle percentage.

## 9 Fault Finding and Removal

### KAESER Service

- ▶ Do not attempt fault removal measures other than those given in this manual. Inform KAESER Service if the fault cannot be removed with the measures suggested.



The messages valid for your machine are dependent on how the individual machine is equipped.

There are three types of fault:

Description	indicated by	see
Alarm (with automatic shut-down)	red LED flashes	9.1
Warning (no shut-down)	yellow LED flashes	9.2
Other faults	no indication	9.3

### 9.1 Alarm messages to the controller (machine shut-down, red LED blinking)

Message	Possible cause	Remedy
blowoff prot.	The activating pressure of the safety valve on the oil separator tank has been exceeded.	Change the oil separator cartridge. Open the shut-off valve in the venting line.
sh.cct.AI 1/AI 2	The connection between the sensor and the analog input is shorted.	Check transducer connections and wiring.
AI 3/AI 4 error	Line-break between the analog input and the sensor. Short circuit to earth.	Check transducer connections and wiring.
sh.cct.AI 5/AI 6	The connection between the sensor and the analog input is shorted.	Check transducer connections and wiring.
AI 7/AI 8 error	Line-break between the analog input and the sensor. Short circuit to earth.	Check transducer connections and wiring.
Model	Machine model uncertain	Contact KAESER service.
Buscontroller	Bus link via the Profibus DP interface	Check line and settings.
PD temperature ↓	Package discharge temperature too low.	Contact KAESER service.
PD temperature ↑	Package discharge temperature too high.	Check the fan motor. Clean the cooler. Check the cooling oil level.
DO 0.6/DO 0.7	Short circuit in the line between DO 0.6 / DO 0.7 outputs and a consumer.	Check line and connections.

Message	Possible cause	Remedy
DO 1.6/DO 1.7	Short circuit in the line between DO 1.6 / DO 1.7 outputs and a consumer.	Check line and connections.
airend rotation	The drive motor is turning in the wrong direction.	Change over phase lines L1 and L2.
ext. message 0	Customer specific:	
...	No data	
ext. message 5		
backpressure	Back pressure in the oil separator tank caused by poor venting.	Check venting line.
HT cell	Fault in the high tension cell.	Contact KAESER service.
V-belts broken	The V-belts parted during operation.	Replace the belts.
no press.buildup	Machine produces no compressed air. Working pressure stays below 50 psig within a preset period.	Check the machine for leaks. Check coupling / V-belts Contact KAESER service.
Condensate drain	Fault in condensate drainage.	Check condensate drainage.
coolingwater low	Cooling water pressure too low.	Check cooling water supply. Check the cooling water stop valve position.
RD compr. p $\uparrow$	Pressure switch for the refrigerant compressor has activated.	Ensure adequate ventilation. Clean the refrigerant condenser. Clean the cooler.
RD compr. T $\uparrow$	Temperature in the refrigerant dryer too high.	Clean the refrigerant condenser. Ensure adequate ventilation. Install an extractor fan. Clean the cooler
RD compr. T $\downarrow$	Temperature in refrigeration dryer too low.	Contact KAESER service.
fan M2 I $\uparrow$	Shutdown of 1 <sup>st</sup> fan motor because of overload.	Investigate cause of shutdown. Reset overload trip.
fan M3 I $\uparrow$	Shutdown of 2 <sup>nd</sup> fan motor because of overload.	Investigate cause of shutdown. Reset overload trip.
fan M4 I $\uparrow$	Shutdown of 3 <sup>rd</sup> fan motor because of overload.	Investigate cause of shutdown. Reset overload trip.
air filter dp $\uparrow$	Air filter clogged.	Clean or renew the filter element.

Message	Possible cause	Remedy
motor I ↑	Drive motor has been shut-down because of overload.	Change the oil separator cartridge. Check minimum pressure/ check valve. Investigate cause of shut-down.
motor T ↑	Drive motor overheated.	Ensure adequate ventilation. Install an extractor. Clean the motor.
motor bearings	Drive motor bearings overheated.	Grease the motor bearings with the greasing device.
mains cont. on?	The mains contactor does not pull in despite ON command.	Check mains contactor and wiring.
mains cont. off?	The mains contactor does not drop out despite OFF command.	Check mains contactor and wiring.
mains voltage ↓	2 <sup>nd</sup> power failure	Check power supply voltage. Check door interlock.
mains monitor	Fault in mains power supply.	Have the mains power supply checked.
Neutral p-switch	Customer specific: No data	
Neutral T-switch	Customer specific: No data	
EMERGENCY-STOP	Emergency-stop-button pressed.	Unlatch the pushbutton.
separator dp ↑	Oil separator cartridge clogged.	Replace the oil separator cartridge.
separator T ↑	Maximum air temperature on oil separator tank outlet exceeded.	Check the line to the trip relay.
oil p ↓	No changeover to load as long as the minimum oil pressure is not reached.	Check oil circulation. Check pressure switch, line and connection.
pRV ↑	The activating pressure of the safety valve on the oil separator tank has been exceeded.	Replace the safety valve.
SFC	Frequency converter faulty.	Contact KAESER service.
SIGMA CONTROL T ↑	Maximum permissible temperature in SIGMA CONTROL housing exceeded.	Ensure adequate ventilation. Ensure that the permissible room temperature is not exceeded. Check control cabinet ventilator (filter mats).

Message	Possible cause	Remedy
soft start	Fault in the soft start equipment.	Contact KAESER service.
Start ↓	Airend discharge temperature (ADT) too low. Ambient temperature below + 40° F.	Heat the compressor room.
ADT ↑	Maximum airend discharge temperature exceeded.	Ensure adequate ventilation. Ensure that the permissible room temperature is not exceeded. Clean the cooler. Cooling air outlet of the machine too near a wall. Check the cooling oil level.
ADT dT/dt	Maximum rise rate of airend discharge temperature (ADT) exceeded.	Check airend and piping to airend. Check the cooling oil level. Check oil circulation.
access doors	Door open with the machine running.	Close the door(s).

Tab. 32 Alarm messages and actions

## 9.2 Warning messages on the controller (yellow LED flashes)

Message	Possible cause	Remedy
access doors	Doors opened with the machine shut down.	Close access doors.
ADT ↑	Maximum airend discharge temperature will soon be reached.	Ensure sufficient ventilation Clean the cooler. The machine's cooling air outlet is too near a wall. Check the cooling oil level. Replace the oil filter.
air filter dp ↑	The pressure drop across the air filter is too high. Air filter element clogged.	Clean/replace the air filter element.
air filter h ↑	The interval for the air filter element check has expired.	Clean/replace the air filter element.
annual maint.	The maintenance interval counter was not reset within a year.	Carry out necessary maintenance and reset one of the following maintenance interval counters: oil filter, oil separator, oil change or air filter.
bearing maint. h ↑	The maintenance interval for greasing the bearings has expired.	Grease the motor bearings.

Message	Possible cause	Remedy
blowoff prot.	Warning The blowoff pressure of the safety relief valve will soon be reached.	Change the oil separator cartridge. Open the shut-off valve in the venting line.
blt.coup.insp.h ↑	The maintenance interval for V-belt tension / coupling inspection has expired.	Visually inspect and tension the V-belts.
blt.coup.chng. h ↑	V-belts / coupling worn.	Change belts / coupling.
Buffer battery	Battery for retention of data is discharged.	Replace the battery
bus alarm	Bus link via Profibus DP interface interrupted	Check bus highway and plug.
Condensate drain	Fault in condensate drainage.	Check condensate drain and lines.
elect. equip. h ↑	The service interval for checking electrical equipment and installation has expired.	Reset the service interval counter.
error: RS 485	Wrong configuration or transmission error.	Check the link/interface connections between the two controllers. Check maximum cable length and screening. 1 master and 1 slave configured.
ext.load signal?	Dubious external load signal Increased cut-out pressure exceeded. The external load control has not switched to idle (off load).	Check settings of the external controller. Take the pressure drops across filters and dryer into account.
ext. message 0	Customer specific: No data	
...		
ext. message 5		
flash memory	Internal controller memory error.	Contact KAESER service.
FC mains	Failure of power supply to the frequency converter.	Check power supply.
mains voltage ↓	1. power failure: Machine was re-started automatically.	Check power supply voltage. Check door interlock.
modem problem	SIGMA CONTROL does not recognise the modem.	Check the link between SIGMA CONTROL and the modem.
motor T ↑	Drive motor overheating.	Ensure adequate ventilation. Install an extractor. Clean the motor.

Message	Possible cause	Remedy
motorstarts /h ↑	The permissible number of motor starts was exceeded during the last 60 minutes.	Extend the idle period. Increase capacity of air receiver. Increase cross-section of piping between compressor and air receiver.
motorstarts /d ↑	The permissible number of motor starts was exceeded during the last 24 hours.	Extend the idle period. Increase capacity of air receiver. Increase cross-section of piping between compressor and air receiver.
motor bearings h ↑	The service interval for the motor bearing change has expired.	Have an authorized KAESER technician replace the motor bearings.
Neutral p-switch	Customer specific: No data	
Neutral T-switch	Customer specific: No data	
no press.buildup	The compressor cannot build-up to working pressure.	Check for air leaks. Check the value for internal pressure given in the "analog data" menu with the reading on the oil separator tank pressure gauge.
oil filter dp ↑	Oil filter clogged.	Oil filter replacement
oil filter h↑	The interval for the next oil filter check has expired.	Oil filter replacement
oil level ↓	Oil level too low.	Top up the cooling oil.
oil T ↓	Cooling oil temperature too low.	Increase room temperature. Check the oil circuit. Check temperature switch, line and connection.
oil change h ↑	The service interval for the oil change has expired.	Change the cooling oil.
oil content ↑	Warning The oil content limit for pure air will soon be reached.	Check the scavenge tube in the oil separator cartridge. Check the dirt trap strainer in the scavenge line. Check air treatment upstream of the measurement.
oil content ↑	The oil content limit for pure air has been exceeded.	Check the scavenge tube in the oil separator cartridge. Check the dirt trap strainer in the scavenge line. Check air treatment upstream of the measurement.



Message	Possible cause	Remedy
PD temperature ↓	Warning Compressor outlet (package discharge) temperature is low.	Contact KAESER service.
PD temperature ↑	Warning Compressor outlet (package discharge) temperature too high.	Clean the cooler. Check the cooling oil level.
RAM	Internal RAM defective.	Contact KAESER service.
set output	The 'set output' test function is activated.	Stop the "set output" mode.
separator dp ↑	Oil separator cartridge clogged.	Change the oil separator cartridge.
separator h ↑	The interval for the next oil separator cartridge check has expired.	Change the oil separator cartridge.
system press. ↓	System pressure has fallen below the "sys.press. low" value. Air consumption too high.	Check air demand. Check transducer connections and wiring. Check "sys.press. low" setting.
system press. ↑ (vacuum machines only)	System pressure is above the "sys.press. high" value.	Check for air leaks. Check "sys.press. high" setting. Check if the machine switches to LOAD.

Tab. 33 Warning messages and actions

### 9.3 Other Alarms

Fault	Possible cause	Remedy
Drive motor overload protection cutout has tripped.	Overload protection cutout is defective or incorrectly set.	Check setting.
	Oil separator cartridge clogged.	Check pressure drop across the separator cartridge. Change the oil separator cartridge if necessary.
	The pressure system does not vent.	Open the shut-off valve in the venting line.
	Motor defective; bearing damage or windings shorted.	
	Airend defective.	

<b>Fault</b>	<b>Possible cause</b>	<b>Remedy</b>
Machine runs but produces no compressed air.	Inlet valve not opening or only opening partially.	
	Venting valve not closing.	
	Leaks in the pressure system.	Check pipework and connections for leaks and tighten any loose fittings.
	Air consumption is greater than the capacity of the compressor.	Check compressed air network for leaks. Shut down the consumer(s).
	Hose coupling or maintenance hose still plugged into the quick-release coupling on the oil separator tank.	Remove coupling or maintenance hose.
Cooling oil runs out of the air filter.	Oil level in the oil separator tank too high.	Drain off oil until the correct level is reached.
	Inlet valve defective.	
Compressor switches between load and idle (off load) more than twice per minute.	Air receiver too small.	
	Flow into the compressed air network restricted.	Increase air pipe diameters. Check filter elements. Switching difference too small (e.g. p1 SD)
Cooling oil leaking into the floor pan.	Hose coupling or maintenance hose still plugged into the quick-release coupling on the oil separator tank.	Remove coupling or maintenance hose.
	Oil cooler leaking	
	Connections leaking.	Tighten connection fittings. Replace seals.
Cooling oil consumption too high.	Unsuitable oil is being used.	Use SIGMA FLUID cooling oil.
	Oil separator cartridge split.	Change the oil separator cartridge.
	Oil level in the oil separator tank too high.	Drain off oil until the correct level is reached.
	Oil return line clogged.	Check dirt trap in the oil return line.

Tab. 34 Other faults and actions

## 10 Maintenance



Maintenance work and work on electrical equipment may only be carried out

- by persons trained on the machine/controller and persons instructed by and under the supervision of a specialist,
- by specialists,
- by authorised KAESER service personnel.

### 10.1 Testing the controller

#### 10.1.1 Displaying binary inputs and outputs

Binary inputs and outputs to and from the controller can be displayed as follows:

Condition: password level 4 is activated.

1. In the main menu keep pressing the *UP* key until `package test` appears in the third line of the display.
2. Press the *Enter* key.

##### Displaying inputs

3. Press the *DOWN* key until `DI test: n` appears in the third line of the display.
4. Press the *Enter* key.

The status of the inputs is shown.

```
      88psi  180°F
-----
DI 0.76543210  input address 0.7... 0.0
      10010101  status: 1= voltage, 0= no voltage)
```

##### Displaying outputs

5. In the `package test` option press the *DOWN* key until `DO test` appears in the third line of the display.
6. Press the *Enter* key.  
The status of the outputs is shown.
7. Press the *DOWN* key for further output addresses.
8. Press the *Escape* key as often as necessary to return to the main menu.

#### 10.1.2 Testing the LEDs on the controller

The LEDs on the controller are tested as follows:

Condition: password level 4 is activated.

1. In the main menu keep pressing the *DOWN* key until `package test` appears in the third line of the display.
2. Press the *Enter* key.

3. Keep pressing the *DOWN* key until `lamps test: n` appears in the third line of the display.
4. Press the *Enter* key.  
The cursor appears inverse over `lamps test: n`.
5. Use the *UP* key to select `y` and confirm with *Enter*.  
The lamps test is now activated. All LEDs start to flash. The test ends automatically after 10 seconds.
6. If one or more of the LEDs does not flash, contact KAESER Service.
7. Press the *Escape* key as often as necessary to return to the main menu.

## 11 Spares, Operating Materials, Service

### 11.1 Note the nameplate

Please quote the data on the nameplate for all inquiries and spare parts orders.

### 11.2 Maintenance Contract

- ▶ Sign a maintenance contract with an authorized KAESER service agent.  
This ensures the utmost reliability and availability of your compressed air supply system.

### 11.3 Service Addresses

Addresses of KAESER agents are given at the end of the machine's service manual.

### 11.4 Displaying the version number, machine model, material number and serial number

1. In the main menu, keep on pressing the *UP* key until *configuration* appears in the third line of the display.
2. Press the *Enter* key.

```
88psi 180°F  
general  
pressure settings  
<  
control mode
```

3. Press the *UP* key and select *general* with the *Enter* key.
4. Press the *DOWN* key to display the following information:

```
88psi 180°F  
type DS 171      machine model  
PN: 7.7001.0    material number  
SN 00234567     serial number
```

5. For further information on the hard and software press the *UP* key and then with the *Enter* key select *version no..*

```
88psi 180°F  
system 2.56      system version  
software 72.15   software version  
hardware 0.6     hardware version
```

6. Press the *Escape* key as often as necessary to return to the main menu.

## **12 Decommissioning, Storage and Transport**

See service manual for the machine.

**13 Annex**

---

---



Main menu	Menu level 1	Menu level 2	Menu level 3	
	Language			
	Communication	RS232		
		RS485		
		Profibus		
		SMS		
	Package test	TUV check	Pressure relief valve ADT alarm	
		DI test		
		DO test		
		Lamps test		
	Components	Motor		
		Booster		
		Air main charging		
		PD temperature		
	Configuration	General		
		Pressure settings		Pressure sensors Compressor Vacuum package Press.act.value
			Pressure settings	Load control
			Control mode	<i>Dual/Quadro/Vario...</i>
			Compressor start	Compressor ON Compressor OFF
		Reset		<i>Remote reset</i>
		I/O periphery	DO functions Show quantities Ext. messages Switch	
			Timer	
			Clock	Clock key <i>Time program</i>
				Password
		Main menu		
		Status	Messages	
			Statistics	
			Printer	
		Analog data	<i>All analog data</i>	
		Operating data	<i>All operating data</i>	
		Maintenance	Maintenance counters	

- 
- ▶ Fold-out: menu overview