

Subject to development-related changes.  
Drawing may be altered only via CAD.

Drawings remain our exclusive property.  
They are intended only for the agreed upon purpose.  
Copies or any other reproduction, including storage, treatment and distribution by use of electronic systems is not allowed for any other than the agreed upon purpose.  
Neither originals nor reproductions may be given to or made available to third parties.

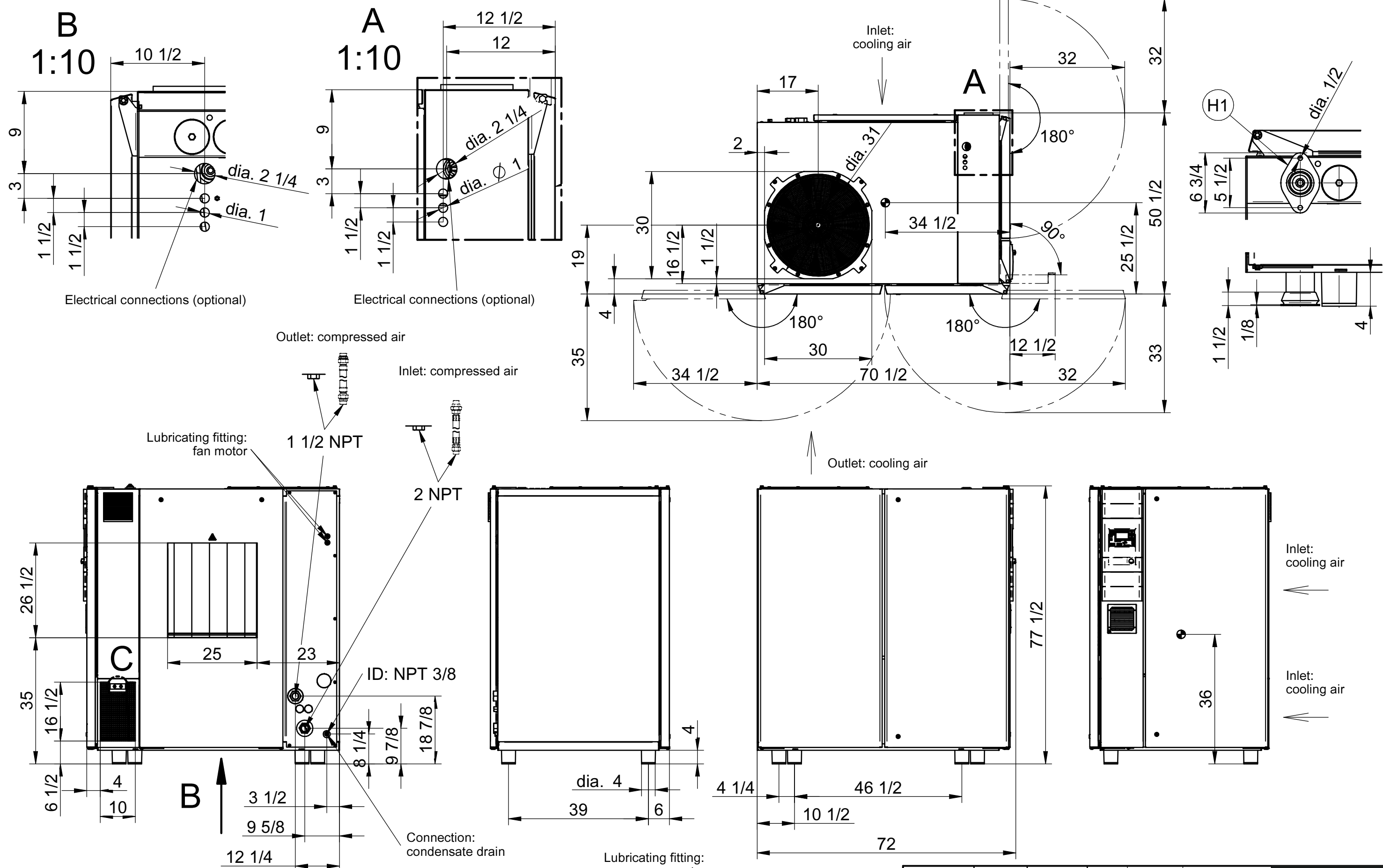

☉: Center of gravity  
Position marginally dependent on design

ID: Internal thread  
Transport opening ≥ machine width + 3,9 inch

**C**  
1:10

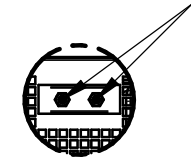

Change number 36993	Projection 	Scale 1:25	Date 23.03.2015	Name KOCH4	<b>KAESER KOMPRESSOREN</b>	
Document TZM 10279513 USE 01	Original A3	Edited 25.06.2015	Released 25.06.2015	KOCH4	Language USE	Sheet 1 / 1
Document TZD 10279513 D 01	Designation <b>DNC.1 K1</b>					Dimension and connection dim.
Status Released						

H1	Machine mountings
K1	Air cooling

Stand 13.02.2013