

Installation and Operating Manual

Rotary lobe blower

HBC vac

Number: 9_9449 31 USE

Manufacturer:

KAESER KOMPRESSOREN SE

96410 Coburg • PO Box 2143 • GERMANY • Tel. +49-(0)9561-6400 • Fax +49-(0)9561-640130

www.kaeser.com

/KKW/BHBCV 2.13 en Z1 SBA-GEBLAESE

20220707 113550

| | | |
|----------|--|----|
| 1 | Regarding this Document | |
| 1.1 | Using this document | 1 |
| 1.2 | Further documents | 1 |
| 1.3 | Copyright | 1 |
| 1.4 | Symbols and labels | 1 |
| 1.4.1 | Warnings | 1 |
| 1.4.2 | Potential damage warnings | 2 |
| 1.4.3 | Other alert notes and their symbols | 2 |
| 2 | Technical Data | |
| 2.1 | Nameplate | 4 |
| 2.2 | Option codes | 4 |
| 2.3 | Weight | 5 |
| 2.4 | Drive motor | 6 |
| 2.5 | Recommended oil | 6 |
| 2.6 | Lubricating oil charge | 6 |
| 2.7 | Permitted pressure drop | 7 |
| 2.8 | Temperature | 7 |
| 2.9 | Ambient and intake conditions | 7 |
| 2.10 | Pressure display | 8 |
| 2.11 | Sound pressure level | 8 |
| 2.12 | Power Supply | 8 |
| 2.13 | Power supply specifications | 9 |
| 2.14 | Options | 9 |
| 2.14.1 | Oil level monitoring | 9 |
| 2.14.2 | Pressure switch | 10 |
| 2.14.3 | Speed monitor | 10 |
| 2.14.4 | Temperature gauge switch | 11 |
| 2.14.5 | Pressure sensor | 12 |
| 2.14.6 | Thermostat | 12 |
| 2.14.7 | Filter pressure differential switch | 12 |
| 2.14.8 | Check valve | 13 |
| 2.14.9 | Auxiliary heating | 13 |
| 2.14.10 | Outdoor installation | 14 |
| 2.14.11 | Piped inlet | 14 |
| 2.14.12 | Fan (sound enclosure) | 14 |
| 2.14.13 | Exhaust silencer (pipeline) | 14 |
| 2.14.14 | Exhaust silencer (diffusion to ambient) | 15 |
| 3 | Safety and Responsibility | |
| 3.1 | Basic instructions | 16 |
| 3.2 | Specified use | 16 |
| 3.3 | Improper use | 16 |
| 3.4 | User's responsibilities | 17 |
| 3.4.1 | Observe statutory and universally accepted regulations | 17 |
| 3.4.2 | Qualified personnel | 17 |
| 3.5 | Dangers | 17 |
| 3.5.1 | Safely dealing with sources of danger | 17 |
| 3.5.2 | Safe machine operation | 19 |
| 3.5.3 | Organizational measures | 21 |
| 3.6 | Danger areas | 22 |
| 3.7 | Safety devices | 22 |
| 3.8 | Safety signs | 22 |
| 3.9 | In emergency | 25 |
| 3.9.1 | Correct fire fighting | 25 |

| | | |
|----------|---|----|
| 3.9.2 | Remove lubricating oil from the skin | 25 |
| 3.10 | Environmental protection | 25 |
| 3.11 | Warranty | 26 |
| 4 | Design and Function | |
| 4.1 | Machine | 27 |
| 4.2 | Blower block | 28 |
| 4.3 | Safety relief valve | 28 |
| 4.4 | Safety devices | 28 |
| 4.5 | Compensator | 29 |
| 4.6 | Pressure gauge | 29 |
| 4.7 | Floating relay contacts | 29 |
| 4.8 | Options | 30 |
| 4.8.1 | Oil level monitor | 30 |
| 4.8.2 | Pressure switch | 30 |
| 4.8.3 | Speed monitor | 30 |
| 4.8.4 | Temperature gauge switch | 31 |
| 4.8.5 | Pressure sensor | 31 |
| 4.8.6 | Thermostat | 32 |
| 4.8.7 | Filter pressure differential switch | 32 |
| 4.8.8 | Check valve | 33 |
| 4.8.9 | Auxiliary heating | 34 |
| 4.8.10 | Outdoor installation | 34 |
| 4.8.11 | Piped inlet | 34 |
| 4.8.12 | Sound enclosure | 35 |
| 4.8.13 | Exhaust silencer (pipeline) | 36 |
| 4.8.14 | Exhaust silencer (diffusion to surroundings) | 36 |
| 5 | Installation and Operating Conditions | |
| 5.1 | Ensuring safety | 38 |
| 5.2 | Installation conditions | 38 |
| 5.2.1 | Determining location and clearances | 38 |
| 5.2.2 | Ensuring adequate ventilation | 39 |
| 5.3 | Outdoor installation | 40 |
| 6 | Installation | |
| 6.1 | Ensuring safety | 41 |
| 6.2 | Reporting transport damage | 42 |
| 6.3 | Anchoring the machine | 42 |
| 6.4 | Do not remove or change the adjusting screw of the pivoted motor base | 42 |
| 6.5 | Connecting the machine to the power supply | 43 |
| 6.5.1 | For frequency control | 43 |
| 6.5.2 | Outdoor installation | 45 |
| 6.6 | Connecting to the vacuum network | 45 |
| 6.7 | Safety devices installed by the user | 46 |
| 6.8 | Options | 46 |
| 6.8.1 | Connecting the oil level monitor | 46 |
| 6.8.2 | Connecting the pressure switch | 46 |
| 6.8.3 | Connecting the speed monitor | 46 |
| 6.8.4 | Connecting the temperature gauge switch | 47 |
| 6.8.5 | Connecting the pressure sensor | 47 |
| 6.8.6 | Connecting the thermostat | 47 |
| 6.8.7 | Connecting the filter pressure differential switch | 47 |
| 6.8.8 | Connecting the auxiliary heater | 47 |
| 6.8.9 | Sound enclosure | 47 |

| | | |
|-----------|--|----|
| 7 | Initial Start-up | |
| 7.1 | Ensuring safety | 49 |
| 7.2 | Instructions to be observed before commissioning | 50 |
| 7.3 | Checking installation and operating conditions | 50 |
| 7.4 | Re-greasing the motor bearings | 51 |
| 7.5 | Checking the direction of rotation for the drive motor | 51 |
| 7.5.1 | Fan (sound enclosure) | 52 |
| 8 | Operation | |
| 8.1 | Switching the machine on and off | 53 |
| 8.1.1 | Switching on | 53 |
| 8.1.2 | Switching off | 53 |
| 8.2 | Switching off in an emergency | 53 |
| 8.3 | Checking the ventilator fan function (sound enclosure) | 54 |
| 9 | Fault Recognition and Rectification | |
| 9.1 | Basic instructions | 55 |
| 9.2 | Faults | 55 |
| 9.3 | Options | 56 |
| 9.3.1 | Sound enclosure faults | 56 |
| 9.3.2 | Faulty pressure sensor | 57 |
| 10 | Maintenance | |
| 10.1 | Ensuring safety | 58 |
| 10.2 | Maintenance schedule | 59 |
| 10.2.1 | Logging maintenance work | 59 |
| 10.2.2 | Regular maintenance tasks | 59 |
| 10.2.3 | Regular service tasks | 60 |
| 10.3 | Sound enclosure | 60 |
| 10.4 | Drive belt maintenance | 61 |
| 10.5 | Checking the oil level | 62 |
| 10.6 | Replenishing lubricating oil | 62 |
| 10.7 | Changing the oil | 63 |
| 10.8 | Air filter maintenance | 65 |
| 10.8.1 | Filter pressure differential switch | 65 |
| 10.8.2 | Air filter maintenance | 65 |
| 10.9 | Machine cleaning | 66 |
| 10.10 | Motor maintenance | 66 |
| 10.10.1 | Drive motor bearings with re-greasing facility | 66 |
| 10.10.2 | Permanently greased drive motor bearings | 68 |
| 10.10.3 | Sound enclosure fan motor | 68 |
| 10.11 | Testing the safety relief valve | 68 |
| 10.12 | Documenting maintenance and service work | 70 |
| 11 | Spares, Operating Materials, Service | |
| 11.1 | Note the nameplate | 71 |
| 11.2 | Ordering consumable parts and operating fluids/materials | 71 |
| 11.3 | Spare parts for service and repair | 71 |
| 11.4 | KAESER AIR SERVICE | 74 |
| 11.5 | Completing the contamination declaration | 74 |
| 12 | Decommissioning, Storage and Transport | |
| 12.1 | Decommissioning | 75 |
| 12.2 | Packing | 75 |
| 12.3 | Transport | 76 |
| 12.3.1 | Safety | 76 |
| 12.3.2 | Transport machine with a pallet truck or forklift truck | 76 |

| | | |
|-----------|--|-----|
| 12.4 | Storage | 76 |
| 12.5 | Disposal | 77 |
| 13 | Annex | |
| 13.1 | Pipeline and instrument flow diagram (P+I diagram) | 78 |
| 13.2 | Dimensional drawing | 81 |
| 13.3 | Sound emission | 85 |
| 13.4 | Drive motor electrical diagram | 87 |
| 13.5 | Electrical diagrams for options | 97 |
| 13.5.1 | Oil level monitoring – wiring diagram | 97 |
| 13.5.2 | Pressure switch wiring diagram | 100 |
| 13.5.3 | Speed monitor wiring diagram | 100 |
| 13.5.4 | Temperature gauge switch wiring diagram | 100 |
| 13.5.5 | Pressure sensor connections | 100 |
| 13.5.6 | Thermostat wiring diagram | 101 |
| 13.5.7 | Filter pressure differential switch wiring diagram | 101 |
| 13.5.8 | Auxiliary heater wiring diagram | 101 |
| 13.5.9 | Sound enclosure fan motor wiring diagram | 106 |
| 13.6 | Project planning data | 106 |

| | | |
|---------|--|-----|
| Fig. 1 | Three-phase star (wye); 4 wire; center point solidly grounded | 9 |
| Fig. 2 | Three-phase star (wye); 3 wire; center point solidly grounded | 9 |
| Fig. 3 | Location of the safety signs on the machine | 22 |
| Fig. 4 | Safety sign location, electronically actuated options | 23 |
| Fig. 5 | Safety sign location, auxiliary heater, Option H2 | 23 |
| Fig. 6 | Safety sign location, weather protection, Option H3 | 23 |
| Fig. 7 | Safety sign location, exhaust silencer, Option H16, H19 | 23 |
| Fig. 8 | Machine | 27 |
| Fig. 9 | Blower block | 28 |
| Fig. 10 | Safety relief valve | 28 |
| Fig. 11 | Compensator | 29 |
| Fig. 12 | Location of the pressure gauge | 29 |
| Fig. 13 | Pressure switch | 30 |
| Fig. 14 | Location of the temperature gauge | 31 |
| Fig. 15 | Pressure sensor | 32 |
| Fig. 16 | Thermostat | 32 |
| Fig. 17 | Filter pressure differential switch | 32 |
| Fig. 18 | Pressure connection to the filter pressure differential switch | 33 |
| Fig. 19 | Filter pressure differential switch function | 33 |
| Fig. 20 | Check valve | 34 |
| Fig. 21 | Auxiliary heating | 34 |
| Fig. 22 | Sound enclosure overview | 35 |
| Fig. 23 | Exhaust silencer (pipeline) | 36 |
| Fig. 24 | Exhaust silencer (diffusion to surroundings) | 37 |
| Fig. 25 | Recommended machine placement and minimum dimensions [in.] | 39 |
| Fig. 26 | Pivoted motor base | 42 |
| Fig. 27 | Assembling the two collar halves | 45 |
| Fig. 28 | Sound enclosure | 60 |
| Fig. 29 | Drive belt maintenance | 61 |
| Fig. 30 | Checking the oil level | 62 |
| Fig. 31 | Replenishing lubricating oil | 63 |
| Fig. 32 | Changing the oil | 64 |
| Fig. 33 | Changing the air filter | 65 |
| Fig. 34 | Drive motor maintenance | 67 |
| Fig. 35 | Maintenance of a drive motor with re-greasing facility | 68 |
| Fig. 36 | Transport | 76 |
| Fig. 37 | Pressure switch wiring diagram | 100 |
| Fig. 38 | Speed monitor wiring diagram | 100 |
| Fig. 39 | Temperature gauge switch wiring diagram | 100 |
| Fig. 40 | Pressure sensor connections | 100 |
| Fig. 41 | Thermostat wiring diagram | 101 |
| Fig. 42 | Filter pressure differential switch wiring diagram | 101 |
| Fig. 43 | Three-phase motor connection | 106 |
| Fig. 44 | Single-phase motor connection | 106 |

| | | |
|---------|---|----|
| Tab. 1 | Danger levels and their definition (personal injury) | 1 |
| Tab. 2 | Danger levels and their definition (damage to property) | 2 |
| Tab. 3 | Nameplate | 4 |
| Tab. 4 | Option codes | 4 |
| Tab. 5 | Weight without sound enclosure | 5 |
| Tab. 6 | Weight with sound enclosure | 5 |
| Tab. 7 | Drive motor | 6 |
| Tab. 8 | Recommended oil | 6 |
| Tab. 9 | Lubricating oil charge | 7 |
| Tab. 10 | Temperature | 7 |
| Tab. 11 | Ambient and intake conditions | 7 |
| Tab. 12 | Pressure display | 8 |
| Tab. 13 | Oil level monitoring (Option C5) | 9 |
| Tab. 14 | Pressure switch (option C9) | 10 |
| Tab. 15 | Speed monitoring sensor (Option C10) | 10 |
| Tab. 16 | Speed monitoring device (Option C10) | 10 |
| Tab. 17 | Setting of the speed monitor evaluation device (Option C10) | 11 |
| Tab. 18 | Temperature gauge switch (Option C13) | 11 |
| Tab. 19 | Pressure sensor (option C14) | 12 |
| Tab. 20 | Thermostat (Option C19) | 12 |
| Tab. 21 | Filter pressure differential switch (Option F5) | 12 |
| Tab. 22 | Check valve (Option G1) | 13 |
| Tab. 23 | Auxiliary heating (Option H2) | 13 |
| Tab. 24 | Thermostat, auxiliary heating (Option H2) | 13 |
| Tab. 25 | Three-phase power supply | 14 |
| Tab. 26 | Single-phase power supply | 14 |
| Tab. 27 | Danger areas | 22 |
| Tab. 28 | Safety signs | 23 |
| Tab. 29 | Compensator torques | 45 |
| Tab. 30 | Recommissioning after storage/standstill | 50 |
| Tab. 31 | Installation conditions checklist | 50 |
| Tab. 32 | Faults and remedies | 55 |
| Tab. 33 | Faults and remedies (option H12) | 56 |
| Tab. 34 | Faults and remedies (Option C14) | 57 |
| Tab. 35 | Regular maintenance tasks | 59 |
| Tab. 36 | Regular service tasks | 60 |
| Tab. 37 | Logged maintenance tasks | 70 |
| Tab. 38 | Consumable parts and operating fluids/materials | 71 |
| Tab. 39 | Sound emission - legend | 85 |

1 Regarding this Document

1.1 Using this document

This document, hereafter called the service manual, contains important information about all life phases of the machine.

The operating manual is a component of the product. It describes the machine as it was at the time of first delivery after manufacture.

- Keep the service manual in a safe place throughout the life of the machine.
- Supply any successive owner or user with this service manual.
- Please insert any amendment or revision of the service manual sent to you.
- Enter details from the machine nameplate and individual items of equipment in the table in chapter 2.

1.2 Further documents

Included with this operating manual are additional documents intended to assist in the safe operation of the machine:

- Manufacturer/installation declaration in accordance with applicable directives.

Missing documents can be requested from KAESER.

- Ensure that all documents are complete and observe the instructions contained within them.
- Ensure that you provide the data from the nameplate when ordering documents.

1.3 Copyright

This operator manual is copyright protected. Queries regarding use or duplication of the documentation should be referred to KAESER. Correct use of information will be fully supported.

1.4 Symbols and labels

- Please note the symbols and labels used in this document.

1.4.1 Warnings

Warnings indicate danger potentially resulting in personal injury, if the measures specified are not taken.

Warnings indicate three levels of danger identified by the corresponding signal word:

| Signal term | Meaning | Consequences of non-compliance |
|-------------|--|---|
| DANGER | Warns of imminent danger | Will very likely result in death or severe injury |
| WARNING | Warns of potentially imminent danger | May result in death or severe injury |
| CAUTION | Warns of a potentially dangerous situation | May result in moderate physical injury |

Tab. 1 Danger levels and their definition (personal injury)

1 Regarding this Document

1.4 Symbols and labels

Warning notes may precede a chapter. They apply to the entire chapter including all sub-sections.

Example:

⚠ DANGER

The type and source of the imminent danger is shown here!

The possible consequences of ignoring a warning are shown here.

The word "DANGER" indicates that death or severe injury can very likely result from ignoring the warning.

➤ *The measures required to protect yourself from danger are shown here.*

Warning notes referring to a sub-section or the subsequent step are integrated into the procedure and numbered as a step.

Example:

1. **⚠ WARNING** *The type and source of the imminent danger is shown here!*
The possible consequences of ignoring a warning are shown here.
The word "WARNING" indicates that death or severe injury may result from ignoring the warning.
➤ *The measures required to protect yourself from danger are shown here.*
2. Always read and comply with warning instructions.

1.4.2 Potential damage warnings

Contrary to the warnings shown above, damage warnings do not indicate potential personal injury.

Damage warnings have only one danger level, identified by this signal word:

| Signal term | Meaning | Consequences of non-compliance |
|-------------|--|--------------------------------|
| NOTE | Warns of a potentially dangerous situation | Damage to property is possible |

Tab. 2 Danger levels and their definition (damage to property)

Example:

NOTICE

The type and source of the imminent danger is shown here!

Potential effects when ignoring the warning are indicated here.



➤ *The protective measures against the damages are shown here.*

➤ Carefully read and fully comply with warnings against damages.

1.4.3 Other alert notes and their symbols



This symbol indicates particular important information.

- Material Here you will find details on special tools, operating materials or spare parts.
- Precondition Here you will find conditional requirements necessary to carry out the task.
The conditional requirements relevant to safety shown here will help you to avoid dangerous situations.
- Option H12 ➤ This symbol is placed by lists of actions comprising one stage of a task.
Operating instructions with several steps are numbered in the sequence of the operating steps.
Information relating to one option only are marked with an option code (e.g., H12 indicates that this section applies only to machines with sound enclosure). Option codes used in this operating manual are explained in chapter 2.2.
-  Information referring to potential problems are identified by a question mark.
The cause is specified in the help text ...
➤ ... as is a solution.
-  This symbol refers to important information or measures concerning environmental protection.
- Further information Further subjects are introduced here.

2 Technical Data

2.1 Nameplate

The machine's nameplate provides the model designation and important technical information. The nameplate is attached to the machine base and at the left side wall of the sound enclosure (Option H12).

The nameplate data relates to Standard intake conditions of 14.7 psi and 68 F.

➤ Enter the data from the nameplate here as a reference.

| Feature | Value |
|-------------------------------|-------|
| Rotary lobe blowers | |
| Material No. | |
| Serial No. | |
| Ambient temperature | |
| Rated power | |
| Rated motor speed | |
| Full load current | |
| Full load current drive motor | |
| Electrical connection | |
| Electrical diagram | |
| Year of manufacture | |

Tab. 3 Nameplate

2.2 Option codes

The table contains a list of available options.

➤ Enter options here as a reference:

| Option | Option code | Available? |
|-------------------------------------|-------------|------------|
| Operating mode: Vacuum | B14 | ✓ |
| Oil level monitoring | C5 | |
| Pressure switch | C9 | |
| Speed monitor | C10 | |
| Temperature gauge switch | C13 | ✓ |
| Pressure transducer | C14 | |
| Thermostat | C19 | |
| Under frequency control | C32 | |
| Filter differential pressure switch | F5 | |
| Check valve | G1 | |
| Installed: ✓ | | |
| Not available: — | | |

| Option | Option code | Available? |
|--|-------------|------------|
| Auxiliary heating | H2 | |
| Outdoor installation | H3 | |
| Intake from pipe network | H11 | ✓ |
| Sound enclosure | H12 | |
| Exhaust silencer (pipeline) | H16 | |
| Exhaust silencer (diffusion to surroundings) | H19 | |
| Installed: ✓ | | |
| Not available: — | | |

Tab. 4 Option codes

2.3 Weight

The values shown are maximum values. The actual weight of individual machines depends on equipment fitted.

Machine without sound enclosure

| Rated power [hp] | Weight [lb] | | |
|------------------|--------------|---|---|
| | HB 950 C vac | — | — |
| 75.0 | 4762 | — | — |
| 100.0 | 5016 | — | — |
| 125.0 | 5236 | — | — |
| 150.0 | 5534 | — | — |
| 175.0 | 5875 | — | — |
| 200.0 | 6184 | — | — |
| 250.0 | 6625 | — | — |
| — | — | — | — |
| — | — | — | — |

Tab. 5 Weight without sound enclosure

Option H12 Machine with sound enclosure

| Rated power [hp] | Weight [lb] | | |
|------------------|--------------|---|---|
| | HB 950 C vac | — | — |
| 75.0 | 6880 | — | — |
| 100.0 | 7125 | — | — |
| 125.0 | 7355 | — | — |
| 150.0 | 7650 | — | — |
| 175.0 | 7995 | — | — |
| 200.0 | 8300 | — | — |
| 250.0 | 8745 | — | — |

| Rated power [hp] | Weight [lb] | | |
|------------------|--------------|---|---|
| | HB 950 C vac | — | — |
| — | — | — | — |
| — | — | — | — |

Tab. 6 Weight with sound enclosure

2.4 Drive motor

➤ Copy the data from the motor nameplate or service plate into the table:

| Feature | Value |
|---|-------|
| Enclosure protection | IP55 |
| Motor bearing re-greasing interval *[h] | 2000 |
| Grease requirement, each bearing [g] | |

h = operating hours

* The lubricating interval is max. 2000 h, even if a longer interval is indicated on the motor service plate.

Tab. 7 Drive motor

2.5 Recommended oil

The lubricant type to be used depends on the operating conditions.

| | OMEGA FLUID | |
|-------------|--|---|
| | SB 220 | FGB 220 |
| Description | Synthetic oil | Synthetic oil |
| Application | Suitable for all applications, except food processing. | Specifically for applications where the compressed air comes into contact with food products. |

Tab. 8 Recommended oil

Further information An adhesive label identifying the used lubricating oil is attached to the blower block and the belt guard.

Information on ordering oil is found in chapter 11.2.

2.6 Lubricating oil charge

The block oil chambers are filled with oil at the factory.

Guide value

| | Drive-end | Gear-end |
|-----------------------------|-----------|----------|
| Lubricating oil charge [qt] | 2.4 ±15% | 3.4 ±15% |

Tab. 9 Lubricating oil charge

2.7 Permitted pressure drop

Ensure that the pressure drop in the downstream pipes is max. 0.15 psi.



The same applies to machines with exhaust silencer (pipe), option H16.

2.8 Temperature

| | HB 950 C vac | — |
|--|--------------|---|
| Maximum block discharge temperature [°F] | 320 | — |
| Maximum temperature differential [K] * | 115 | — |

* Discharge temperature minus inlet temperature

Tab. 10 Temperature

2.9 Ambient and intake conditions

The following conditions must be maintained:

- No salty atmosphere in the immediate vicinity of the machine.
- The air must be free of chemicals or explosive substances.

| | HB 950 C vac | — |
|--|--------------|---|
| Permissible ambient temperature [°F] | 23 – 104 | — |
| Machine with connected auxiliary heating and sound enclosure (Options H2, H12) Permissible ambient temperature [°F] | 5 – 104 | — |
| Permissible intake temperature [°F] | 14 – 104 | — |
| Relative humidity [%] | 0 – 80 | — |
| Maximum altitude AMSL [ft.] | 3281 | — |

Tab. 11 Ambient and intake conditions



Differing ambient and intake conditions require the recalculation of the performance data, and are permissible only upon agreement by the manufacturer.

Further information The wiring diagram for Option H2 in chapter 13.5.8 contains further details of the power supply connection.

2.10 Pressure display

| Feature | Data |
|------------------------|--------------|
| Indicator range [psig] | -8.7 – +14.5 |

Tab. 12 Pressure display

2.11 Sound pressure level

Operating state LOAD under the following conditions:

- Nominal speed
- Nominal suction capacity
- Nominal pressure

Measuring condition according to DIN EN ISO 2151 and basic standard ISO 9614-2:

- Measurement distance: 3 ft.
- Tolerance: ± 3 dB(A)
- Sound insulated pipeline

Further information The sound pressure level and sound power level values for your machine are provided in the tables shown in chapter 13.3.

These values refer to the design condition. They do not apply to the control range with frequency converter.

2.12 Power Supply

Basic requirements

The machine is designed for an electrical supply according to National Electric Code (NEC), edition 2020, particularly article 670 and NFPA 79, edition 2021, particularly section 4.3. In the absence of any user-specified alternatives, the limits given in these standards must be adhered to. Consult manufacturer for any other specific power supply.

The incoming line within the control panel should be as short as possible.

If external sensors or communication lines are to be connected to the machine, use shielded cables and insert the same through EMC fittings into the control panel.

Three-phase

Do **NOT** operate package on any unsymmetrical power supply. Also do **NOT** operate package on power supplies such as a three phase WYE system with center point not solidly grounded or three-phase (open) delta.

The machine requires a symmetrical three-phase power supply transformer with a WYE configuration output as shown in Figure 1 and Figure 2. In a symmetrical three phase supply the phase angles and voltages are all the same.

Other power supplies are not suitable.

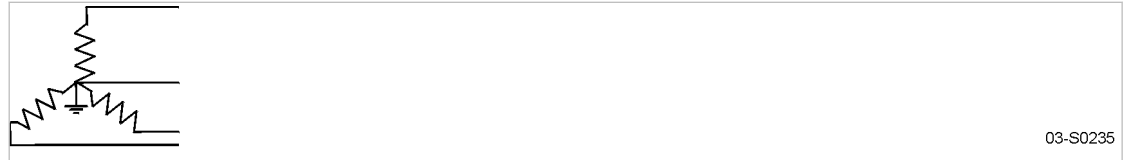

Fig. 1 Three-phase star (wye); 4 wire; center point solidly grounded

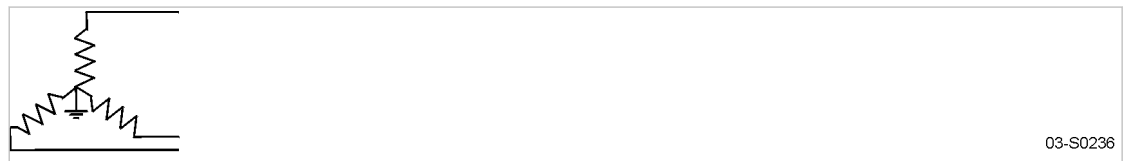

Fig. 2 Three-phase star (wye); 3 wire; center point solidly grounded

Further information Please contact an authorized KAESER service representative for options.
The electrical diagram 13.4 contains further specifications for electrical connection.

2.13 Power supply specifications

The following multi-strand copper core wires are given according to 2020 NEC 310.1, Table 310.15(B)(16) for 40 °C ambient temperature.

If other local conditions prevail, like for example high temperature, the cross section should be checked and adjusted according to 2020 NEC 110.14(C), 220.3, 310.15, Table 310.15(B)(2)(a), 430.6, 430.22, 430.24, 670.4(A) and other local codes.

Dual element time delay fuses are selected according to 2020 NEC 240.6 , 430.52 and tables 430.52, 430.248 and 430.250.

We strongly suggest using a separate copper conductor for the equipment GROUNDING. 2020 NEC Table 250.122 will point out the “minimum size”, however, we recommend a ground conductor for the same size as the power leads, if local codes allow.

2.14 Options

Technical data for the options available for your machine are given in the following.

2.14.1 Option C5 Oil level monitoring

| Feature | Data |
|-------------------------|-----------------|
| Max. voltage [V] | 48 |
| Switching current [A] | 0.5 |
| Switching capacity [hp] | 0.03 |
| Type of contact | Normally closed |

| Feature | Data |
|------------------|------|
| Protection class | IP67 |

Tab. 13 Oil level monitoring (Option C5)

Further information The wiring diagram for Option C5 in chapter 13.5 contains further details of the power supply.

2.14.2 Option C9 Pressure switch

| Feature | Data | |
|---|----------------|-----|
| Max. contact load at 250 V [A] | Inductive load | 0.5 |
| | Resistive load | 1.0 |
| Protection (with cover, electrical connection upwards) | IP54 | |

Tab. 14 Pressure switch (option C9)

Further information The wiring diagram for option C9 in chapter 13.5 contains further details of the power supply connection.

2.14.3 Option C10 Speed monitor

Sensor

| Feature | Data |
|--------------------------------------|-------------|
| Rated switching distance S_n [in.] | 0.04 – 0.12 |
| Installation conditions | Not flush |
| Output function | DC PNP/NPN |
| Enclosure protection | IP 67 |
| Connection | M12 |
| Working principle | Inductive |

Tab. 15 Speed monitoring sensor (Option C10)

Sensor

| Feature | Data |
|--|--|
| Rated voltage [V] | 110 – 240 AC/DC (50 – 60 Hz) / 27 DC (typ. 24 DC) |
| Contact load capacity | 6 A (250 V AC); B300, R300 |
| Power consumption [VA] | 5 |
| Start override [s] | 0 – 1000 |
| Ambient temperature [°F] | -4 – +140 |
| Degree of protection - enclosure/terminals | IP 50 / IP 20 |

| Feature | Data |
|------------------|------------------------------------|
| Cable connection | up to 2.5 mm ² (AWG 14) |

Tab. 16 Speed monitoring device (Option C10)

Sensor setting

| Feature | Data | | |
|---|------------------|------------------|----------|
| Display format | DIM=0 (rpm) | | |
| Number of control caps, input 1 | NC1=2 | | |
| Memory function outputs 1 and 2 | SO1=0 (inactive) | SO2=0 (inactive) | |
| Switching function outputs 1 and 2 | FO1=2 | FO2=3 | AO3=4.0 |
| Analogue starting value for analogue output 3 [mA] | | | |
| Switching point outputs 1 and 2 [rpm] | SP1=500 | SP2=1000 | FA3=1000 |
| Analogue starting value for analogue output 3 [rpm] | | | |
| Hysteresis for switching points 1 and 2 [%] | HY1=3 | HY2=5 | |
| Start override time outputs 1 and 2 [s] | ST1=60.0 | ST2=0.0 | |
| Delay time outputs 1 and 2 [s] | DT1=10.0 | DT2=0.0 | |
| Wiping function outputs 1 and 2 [s] | FT1=0.0 | FT2=0.0 | |

Tab. 17 Setting of the speed monitor evaluation device (Option C10)

Further information The wiring diagram for Option C10 in chapter 13.5 contains further details of the power supply connection.

2.14.4 Option C13 Temperature gauge switch

| Feature | Data | |
|--|----------------|-------|
| Switching capacity at 250 V(AC) [A] Single pole micro-switch with changeover contact | Inductive load | 1.5 |
| | Resistive load | 5.0 |
| Switching differential of the scale range [%] | <3 | |
| Switching point tolerance [%] (of the scale range related to the cut-out point at rising temperature) | ±5 | |
| Minimum voltage [V] [AC] Minimum current [mA] (Switching safety) | 24 20 | |
| Enclosure protection | Front | IP 53 |
| | Rear | IP 54 |

Tab. 18 Temperature gauge switch (Option C13)

Further information The electrical diagram for Option C13 in chapter 13.5 contains further details for the power supply connection.

**2.14.5 Option C14
 Pressure sensor**

| Feature | Data |
|---------------------------------------|-----------------------------------|
| Output signal [mA] | 4 – 20 |
| Parasitic energy [V] | $U_B = DC 10 - 30$ |
| Permissible apparent resistance [Ohm] | $R_A = (U_B [V] - 10 V) / 0.02 A$ |
| Enclosure protection | IP 65 |

Tab. 19 Pressure sensor (option C14)

Further information The wiring diagram for option C14 in chapter 13.5 contains further details of the power supply connection.

**2.14.6 Option C19, H12
 Thermostat**

| Feature | Data |
|--|---|
| Spring switch with change-over contact | 1-pole |
| Switching capacity NC contact (1-2) | AC 230 V / 2.5 A / $\cos\phi=0.6$ AC 230 V / 16 A / $\cos\phi=1$ DC 230 V / 0.25 A |
| Switching capacity NO contact (1-4) | AC 230 V / 2.5 A / $\cos\phi=0.6$ AC 230 V / 6.3 A / $\cos\phi=1$ DC 230 V / 0.25 A |
| Switching differential scale starting position [%] | 6 |
| Switching differential scale end position [%] | 1.5 |
| Enclosure protection | IP 54 |

Tab. 20 Thermostat (Option C19)

Further information The electrical diagram for Option C19 in chapter 13.5 contains further details for the power supply connection.

**2.14.7 Option F5
 Filter pressure differential switch**

| Feature | Data |
|---|---|
| Pressure differential, adjustable [psi] | 0.04 – 0.73 |
| Voltage [V] | (AC) eff., min. 10 (AC) max. 250 (DC) min. 12 (DC) max. 48 |
| Rated current [A] | (AC) 10 |

| Feature | Data |
|----------------------|---|
| Switching current | (AC) eff., min. 20 mA (AC) max. 6 A, $\cos\phi = 1.0$ (AC) max. 3 A, $\cos\phi = 0.6$ (DC) min. 20 mA (DC) max. 1 A |
| Enclosure protection | IP 54 |

Tab. 21 Filter pressure differential switch (Option F5)

Further information The electrical diagram for Option F5 in chapter 13.5 contains further details for the power supply connection.

2.14.8 Option G1 Check valve

| Nominal pipe size | Max. pressure and back pressure [psi] |
|-------------------|---------------------------------------|
| DN 250 | 17.4 |

Tab. 22 Check valve (Option G1)

2.14.9 Option H2, H12 Auxiliary heating

| Rated voltage [V] | 115 | 208 | 230 |
|-----------------------|---------|---------|---------|
| Heating capacity [hp] | 3x 0.21 | 3x 0.21 | 3x 0.21 |
| Number of radiators | 3 | 3 | 3 |

Tab. 23 Auxiliary heating (Option H2)

Thermostat

| Feature | Data |
|--|---|
| Snap switch with changeover contact | 1-pole |
| Switching capacity NC contact (1-2) | AC 230 V / 2.5 A / $\cos\phi=0.6$ AC 230 V / 16 A / $\cos\phi=1$ DC 230 V / 0.25 A |
| Switching capacity NO contact (1-4) | AC 230 V / 2.5 A / $\cos\phi=0.6$ AC 230 V / 6.3 A / $\cos\phi=1$ DC 230 V / 0.25 A |
| Switching differential scale starting position [%] | 6 |
| Switching differential scale end position [%] | 1.5 |
| Enclosure protection | IP 54 |

Tab. 24 Thermostat, auxiliary heating (Option H2)

Further information The electrical diagram for Option H2 in chapter 13.5 contains further details of the power supply connection.

2.14.10 Option H3, H12
Outdoor installation

Protection against lightning is the responsibility of the operator.

Material Stainless steel weather protection roof

- Note the maximum permissible loads. For example, for snow load zone 2 and wind load zone 2, see DIN EN 1991 Effects on structures - snow loads and wind loads



Deviating loads for outdoor installation may require design modifications and are only permissible following consultation with the manufacturer.

Further information The dimensional drawings in chapter 13.2 provide information regarding the necessary dimensions for outdoor installation.

2.14.11 Option H11
Piped inlet

The dimensional drawings in chapter 13.2 include connection dimensions.

2.14.12 Option H12
Fan (sound enclosure)

Set overload protection devices to 1.1 times nominal value.

Further information See chapter 6.8.9.2 for the fan connection and chapter 13.5.9 for the connection wiring diagram.

Three-phase power supply

| Rated voltage [V] | Δ-208/Y-360 | Δ-220/Y-380 | Δ-230/Y-400 | Y-460 | Y-575 |
|------------------------|-------------|-------------|-------------|-------|-------|
| Delivery [cfm] | 2060 | 2060 | 2060 | 2060 | 1942 |
| Rated current ±10% [A] | 0.72/0.42 | 0.97/0.56 | 0.73/0.42 | 0.41 | 0.33 |
| Degree of protection | IP55 | IP55 | IP55 | IP55 | IP55 |

Tab. 25 Three-phase power supply

Single-phase power supply

| Rated voltage [V] | 115 | 230 |
|------------------------|------|------|
| Delivery [cfm] | 2060 | 2060 |
| Rated current ±10% [A] | 2.60 | 0.98 |
| Degree of protection | IP55 | IP65 |

Tab. 26 Single-phase power supply

2.14.13 Option H16, H12
Exhaust silencer (pipeline)

The mounting position is shown in the dimensional drawing in chapter 13.2.

2.14.14 Option H19, H12
Exhaust silencer (diffusion to ambient)

The mounting position is shown in the dimensional drawing in chapter 13.2.

3 Safety and Responsibility

3.1 Basic instructions

The machine is manufactured to the latest engineering standards and acknowledged safety regulations. Nevertheless, dangers can arise through its operation:

- Danger to life and limb of the operator or third parties,
- Damages to the machine and other material assets.



Disregard of warning or safety instructions can cause serious injuries!

- Read the operating and installation manual carefully and take note of the contents for safe machine operation.
- Use this machine only if it is in a technically perfect condition and only for the purpose for which it is intended; observe all safety measures and the instructions in the service manual!
- Immediately rectify (have rectified) any faults that could be detrimental to safety!

3.2 Specified use

The machine is designed exclusively for the generation of vacuum in a commercial or industrial environment where air as delivery medium is approved for use. Any other use is considered incorrect. The manufacturer is not liable for any damages that may result from incorrect use. The user alone is liable for any risks incurred.

- Comply with the instructions in this operating manual.
- Operate the machine only within its performance limits and under the permitted ambient conditions.
- Operate the machine only when completely installed.

3.3 Improper use

Improper usage can cause damage to property and/or (severe) injuries.

- Only use the machine as intended.
- Use hot cooling air for heating purposes only if there is no risk to the health of humans or animals. If necessary, cooling air should be treated by suitable means.
- Do not allow the machine to take in toxic, acidic, flammable or explosive gases or vapors.
- Do not operate the machine in areas in which specific requirements with regard to explosion protection are in force.
- Intake of solid particles > 0.004 inch is not permitted.
- Persons are not allowed to remain near the exhaust outlet.
- Exhaust air must not be used for breathing purposes.

3.4 User's responsibilities

3.4.1 Observe statutory and universally accepted regulations

These are, for example, nationally implemented European directives and/or applicable national legislation, safety and accident prevention regulations.

- Observe relevant statutory and accepted regulations during installation, operation and maintenance of the machine.

3.4.2 Qualified personnel

Suitable personnel are experts who, by virtue of their training, knowledge and experience as well as their knowledge of relevant regulations can assess the work to be done and recognize the possible dangers involved.

Authorized operating personnel possess the following qualifications:

- they are of legal age,
- are familiar with and adhere to the safety instructions and sections of the operating manual relevant to operation,
- have received adequate training and authorization to operate electrical and vacuum devices.

Authorized installation and maintenance personnel have the following qualifications:

- they are of legal age,
- must have read, be familiar with and adhere to the safety instructions and sections of the operating manual applicable to installation and maintenance,
- are fully familiar with the safety concepts and regulations of electrical and vacuum engineering,
- are able to recognize the possible dangers of electrical and vacuum devices and take appropriate measures to safeguard persons and property,
- have received adequate training in and authorization for the safe installation and maintenance of this machine.

- Ensure that personnel entrusted with operation, installation and maintenance are qualified and authorised to carry out their tasks.

3.5 Dangers

Basic instructions

Information concerning the various forms of danger that can arise during machine operation are found here.

Basic safety instructions are found in this service manual at the beginning of each chapter in the section entitled 'Safety'.

Warning instructions are found before a potentially dangerous task.

3.5.1 Safely dealing with sources of danger

The following describes the various forms of danger that can occur during machine operation.

Electricity

Touching voltage carrying components can result in electric shocks, burns or death.

- All power supplies must be fitted with lockable isolating devices by the user.
- Allow only qualified and authorized electricians or trained personnel under the supervision of a qualified and authorized electrician to carry out work on electrical equipment according to electrical engineering regulations.
- Before commissioning or re-commissioning the machine, the user must ensure adequate protection against electric shock from direct or indirect contact.
- Before starting any work on electrical equipment:
Switch off and lock out the power supply disconnecting device, and verify the absence of any voltage.
- Switch off any external power sources.
These may be connections to the electric machine heating for example.
- Use fuses corresponding to machine power.
- Regularly check that all electrical connections are tight and in proper condition.

Forces of compression

- Do not carry out welding, heat treatment or mechanical modifications on pressurized components, as this adversely affects the components' resistance to pressure.
The safety of the machine cannot be guaranteed.

Quality of discharge air

The quality of the discharge air and any substances it may contain depends on the quality of the air drawn from the vacuum network.

- Never breathe in exhaust air.
- Lead exhaust air outdoors to a point far from any persons.

Spring forces

Springs under tension or compression store energy. Uncontrolled release of this energy can cause serious injury or death.

Safety relief valves are heavily spring-loaded.

- Do not open or dismantle any valves.

Rotating components

Touching the fan wheel or the belt drive while the machine is running can result in serious injury.

- Do not remove separating protective installations when the machine is running.
- Switch off and lock out the power supply disconnecting device, and verify the absence of any voltage.
- Wear close-fitting clothes and a hair net if necessary.
- Ensure that all covers and safety guards are in place and secured before re-starting.

Temperature

High temperatures are generated during compression. Touching hot components may cause injuries.

- Switch off and lock out the power supply disconnecting device and verify the absence of any voltage.
- Wear close-fitting clothes and a hair net if necessary.
- Ensure that all covers and safety guards are in place and secured before re-starting.

Noise

The sound enclosure absorbs the machine noise to a tolerable level. This function will be effective only if the sound enclosure is closed.

- Wear hearing protection if necessary.

Operating fluids/materials

The used operating fluids and materials can cause adverse health effects. Suitable safety measures must be taken in order to prevent injuries.

- Strictly forbid fire, open flame and smoking.
- Follow safety regulations when dealing with oils, lubricants, and chemical substances.
- Avoid contact with skin and eyes.
- Do not inhale oil mist and vapors.
- Do not eat or drink while handling lubricants.
- Keep suitable fire extinguishing agents ready for use.
- Use only KAESER approved operating materials.

Unsuitable spare parts

Unsuitable spare parts compromise the safety of the machine.

- Use only spare parts approved by the manufacturer for use in this machine.
- Use only genuine KAESER replacement parts on pressure bearing parts.

Conversion or modification of the machine

Modifications, additions or conversions to or of the machine can result in unpredictable hazards.

- Do not convert or modify the machine!
- Prior to any technical modification and expansions of the machine, obtain the written approval of the manufacturer.

Extending or modifying the compressor station

If dimensioned appropriately, safety relief valves reliably prevent an impermissible rise in pressure. New dangers may arise if you modify or extend the compressor station.

- When extending or modifying the compressor system:
Check the blow-off capacity of the safety relief valves prior to installing the new machine.
- If the blow-off capacity is insufficient:
Install safety relief valves with larger blow-off capacity.

3.5.2 Safe machine operation

The following is information supporting you in the safe handling of the machine during individual product life phases.

Personal protective equipment

When working on the machine you may be exposed to dangers that can result in accidents with severe adverse health effects.

- Wear protective clothing as necessary.

Suitable protective clothing (examples):

- Safety work wear
- Protective gloves
- Safety boots
- Eye protection
- Ear protection

Transporting

The weight and size of the machine require safety measures during its transport to prevent accidents.

- Use suitable lifting gear that conforms to local safety regulations.
- Allow transportation only by personnel trained in the safe movement of loads.
- Attach lifting gear only to suitable lifting points.
- Be aware of the center of gravity to avoid tipping.
- Make sure the danger zone is clear of personnel.
- Do not step onto machine components to climb up the machine.

Assembly

- Make sure no power is applied when electrical connections are made.
- Use only electrical cables that are suitable and approved for the surroundings and electrical loads applied.
- Attach or detach pipework only with the machine at atmospheric pressure.
- Use only pressure lines that are suitable and approved for the maximum working vacuum and the intended medium.
- Do not allow connection pipes to be placed under mechanical stress.
- Do not induce any forces into the machine via the connections, so that the compressive forces must be balanced by bracing.
- Do not step onto machine components to climb up the machine.

Installation

A suitable installation location for the machine prevents accidents and faults.

- Install the machine in a suitable compressor room.
- Ensure sufficient and suitable lighting such that the display can be read and work carried out comfortably and safely.
- Ensure accessibility so that all work on the machine can be carried out without danger or hindrance.
- If installed outdoors, the machine must be protected from frost, direct sunlight, dust, rain and splashing water.
- Do not operate in areas in which specific requirements with regard to explosion protection are in force.

- Ensure adequate ventilation.
- Place the machine in such a manner that the working conditions in its environment are not impaired.
- Comply with limit values for ambient temperature and humidity.
- The intake air must not contain any damaging contaminants, Damaging contaminants are for instance: explosive or chemically instable gases and vapors, acid or base forming substances such as ammonia, chlorine or hydrogen sulfide.
- Do not position the machine in the warm exhaust air flow from other machines.
- Keep suitable fire extinguishing agents ready for use.

Commissioning, operation and maintenance

During commissioning, operation and maintenance you may be exposed to dangers resulting from, e.g., electricity, pressure and temperature. Careless actions can cause accidents with severe adverse effects for your health.

- Allow maintenance work to be carried out only by authorized personnel.
- Wear close-fitting, flame-resistant clothing. Wear protective clothing as necessary.
- Switch off and lock out the power supply disconnecting device and verify the absence of voltage.
- Check that there is no voltage on floating relay contacts.
- Vent all components and chambers under vacuum to atmospheric pressure.
- Allow the machine to cool down.
- Do not open the sound enclosure while the machine is switched on.
- Do not open or dismantle any valves.
- Use only spare parts approved by KAESER for use in this machine.
- Carry out regular inspections:
for visible damage,
of safety installations,
of the EMERGENCY STOP push button,
of any components requiring monitoring.
- Pay particular attention to cleanliness during all maintenance and repair work. Cover components and openings with clean cloths, paper or tape to keep them clean.
- Do not leave any loose components, tools or cleaning rags on or in the machine.
- Components removed from the machine can still be dangerous.
Do not attempt to open or destroy any components taken from the machine.

Decommissioning, storage and disposal:

Improper handling of old operating fluids and components represent a danger for the environment.

- Drain off fluids and dispose of them according to applicable environmental regulations. These include, for example, lubricating oil.
- Dispose of the machine in accordance with local environmental regulations.

3.5.3 Organizational measures

- Designate personnel and their responsibilities.
- Give clear instructions on reporting faults and damage to the machine.
- Give instructions on fire reporting and fire-fighting measures.

3.6 Danger areas

The table gives information on areas dangerous to personnel.

Only authorized personnel may enter these areas.

| Function | Danger area | Authorized personnel |
|--------------|---|---|
| Transporting | Within a 10 ft radius of the machine. | Installation personnel for transporting preparation. No personnel during transporting. |
| | Beneath the lifted machine. | No personnel! |
| Installation | Within the machine. Within 3 ft radius of the machine and its power supply cables. | Installation personnel |
| Operation | Within a 3 ft radius of the machine. | Operating personnel |
| Maintenance | Within the machine. | Maintenance personnel |
| | Within a 3 ft radius of the machine. | |

Tab. 27 Danger areas

3.7 Safety devices

Various safety devices ensure safe working with the machine.

- Do not change, bypass or disable safety devices.
- Check safety devices for correct function regularly.
- Do not remove or obliterate labels and notices.
- Ensure that labels and notices are clearly legible.

Further information More information on safety devices is contained in chapter 4, section 4.4.

3.8 Safety signs

The illustration shows the location of the safety signs on the machine. Table 28 lists the various safety signs used and their meanings.

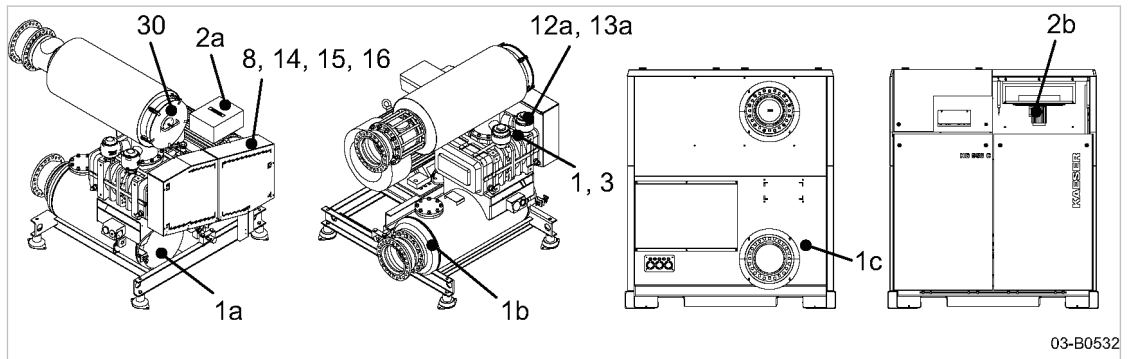

Fig. 3 Location of the safety signs on the machine

Options

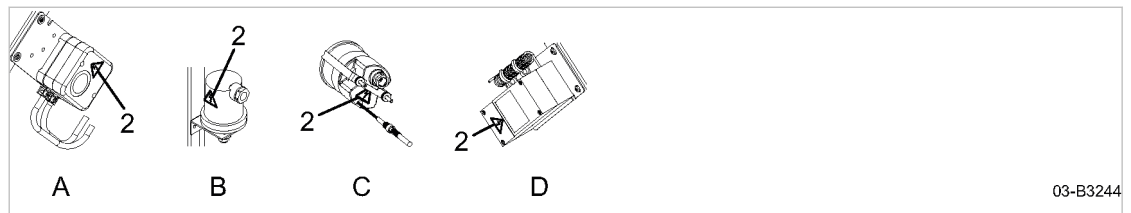

Fig. 4 Safety sign location, electronically actuated options

- | | | | |
|----------|---|----------|---|
| A | Filter differential pressure switch (Option F5) | C | Temperature display with switching point (Option C13) |
| B | Pressure switch (Option C9) | D | Thermostat (Option C19) |

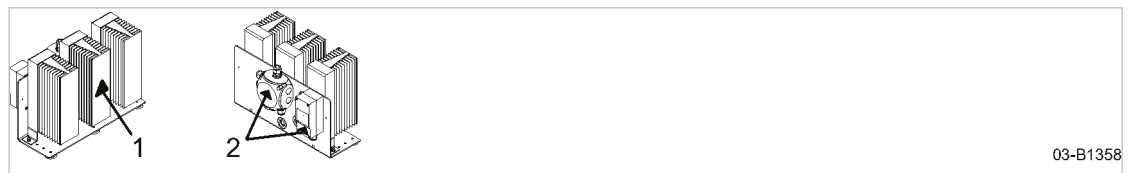

Fig. 5 Safety sign location, auxiliary heater, Option H2

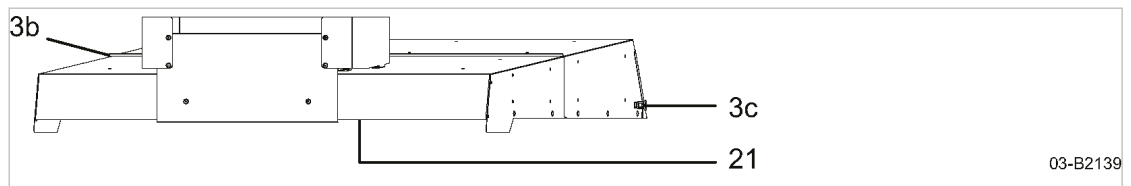

Fig. 6 Safety sign location, weather protection, Option H3

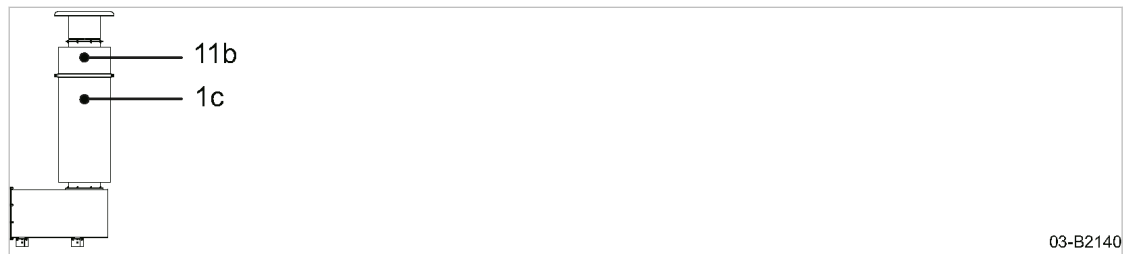













Fig. 7 Safety sign location, exhaust silencer, Option H16, H19

| Item | Symbol | Meaning |
|------|--------|--|
| 1 | | Hot surface can cause burns! |
| 1a | | Risk of burns caused by contact with hot components. |
| 1b | | ➤ Let the machine cool down. |
| 1c | | ➤ Wear long-sleeved garments (not synthetics such as polyester) and protective gloves. |
| 2 | | Danger of fatal injury from touching electrically live components! |
| 2a | | ➤ Switch off and lock out/tag out the power supply disconnecting device and verify the absence of any voltage before opening any machine enclosure or guard. |
| 2b | | |

| Item | Symbol | Meaning |
|----------|---|---|
| 3 |  | <p>Rotating rotors!</p> <p>Risk of serious lacerations or even severing of extremities (fingers) from rotating components.</p> <ul style="list-style-type: none"> ➤ Operate the machine only when a connection is made to the inlet port. ➤ Switch off and lock out/tag out the power supply disconnecting device and verify the absence of any voltage before opening any machine enclosure or guard. |
| 3b 3c |  | <p>Injuries (to the hands in particular) due to shearing effects!</p> <ul style="list-style-type: none"> ➤ Carefully close the flap in the weather protection roof (Option H3). ➤ Always wear protective gloves. |
| 8 |  | <p>Personal injury or damage to the machine by incorrect operation!</p> <ul style="list-style-type: none"> ➤ Read and understand the service manual and all safety signs before switching on this machine. |
| 11b |  | <p>Danger of burns from hot gas!</p> <ul style="list-style-type: none"> ➤ Do not enter danger zone. ➤ Wear long-sleeved garments (not synthetics such as polyester) and protective gloves. |
| 12a |  | <p>Serious injury or death can result from loosening or opening component that is under pressure and heavily spring loaded!</p> <ul style="list-style-type: none"> ➤ Do not open or dismantle the valve. ➤ Contact an authorized KAESER service representative if a fault occurs. |
| 13a |  | <p>Serious injury or death can result from loosening or opening component under pressure!</p> <ul style="list-style-type: none"> ➤ Depressurize all pressurized components and enclosures. ➤ Ensure the machine remains depressurized. ➤ Check that the machine is depressurized. |
| 14 |  | <p>Severe injury could result from touching the v-belt drive while it is rotating!</p> <ul style="list-style-type: none"> ➤ Switch off and lock out/tag out the power supply disconnecting device and verify the absence of any voltage before opening any machine enclosure or guard. |
| 15 |  | <p>Injury and/or contamination can result from breathing compressed air! Contamination of food can result from using untreated compressed air for food processing!</p> <ul style="list-style-type: none"> ➤ Never breathe untreated compressed air. ➤ Air from this compressor must meet OSHA 29CFR1910.134 and FDA 21CFR178.3570 standards, if used for breathing or food processing. Use proper compressed air treatment. |
| 16 |  | <p>Wear hearing protection!</p> <ul style="list-style-type: none"> ➤ Noise from running machine (without sound enclosure). ➤ Loud noise if any part of the sound enclosure (Option H12) is open while the machine is running. |
| 21 |  | <p>Risk of Impact!</p> <p>Potential risk of head injuries when closing the hatch.</p> <ul style="list-style-type: none"> ➤ Wear proper head protection when the hatch is open. |

| Item | Symbol | Meaning |
|------|---|--|
| 30 |  | Danger of bursting from positive pressure! ➤ Always remove the cover when checking the direction of rotation of the blower block. |

Tab. 28 Safety signs

3.9 In emergency

3.9.1 Correct fire fighting

Suitable extinguishing agents

- Foam
- Carbon dioxide
- Sand or dirt

Unsuitable or unsafe extinguishing agents

- Strong jet of water
1. Keep calm.
 2. Give the alarm.
 3. Switch off the power supply disconnecting device, if possible.
 4. Move to safety.
 - Warn persons in danger.
 - Help incapacitated persons.
 - Close the doors.
 5. Try to extinguish the fire if you have the skill to do so.

3.9.2 Remove lubricating oil from the skin.

- Eye contact:
Rinse eyes thoroughly with lukewarm water and seek medical assistance.
- Skin contact:
Wash off immediately.

3.10 Environmental protection

- Store and dispose of operating materials and replaced parts in accordance with local environmental protection regulations.
- Observe national regulations.
This applies particularly to parts contaminated with lubricating oil.



- Do not allow lubricating oil to escape to the environment or into the sewage system.

3.11 Warranty

This operator manual contains no independent warranty commitment. Our general terms and conditions of business apply with regard to warranty.

A condition of our warranty is that the machine is used for the purpose for which it is intended under the conditions specified.

Due to the multitude applications for which the machine is suitable the obligation lies with the user to determine its suitability for his specific application.

In addition, we accept no warranty obligation for:

- the use of unsuitable parts or operating materials,
- unauthorized modifications,
- incorrect maintenance,
- incorrect repair.

Correct maintenance and repair includes the use of original spare parts and operating materials.

- Obtain confirmation from KAESER that your specific operating conditions are suitable.

4 Design and Function

4.1 Machine

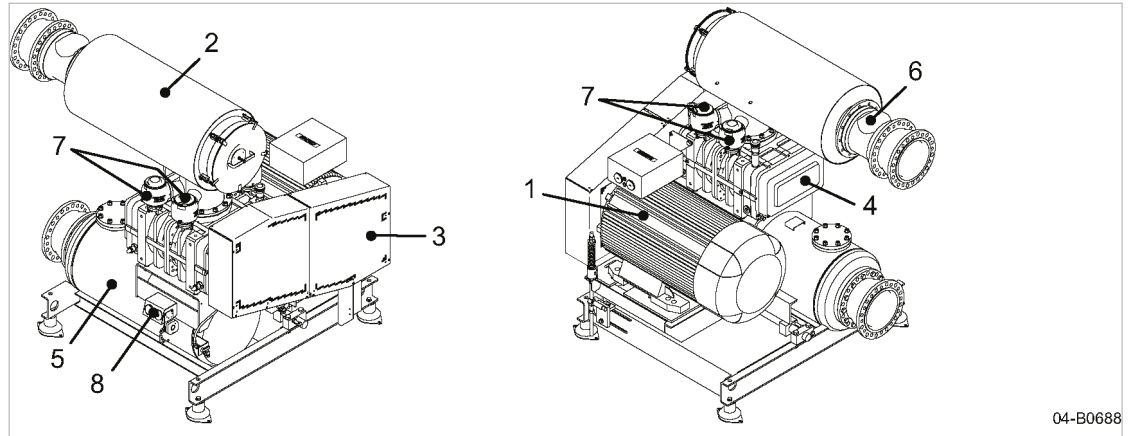

Fig. 8 Machine

- | | | | |
|---|----------------|---|-----------------------------|
| ① | Drive motor | ⑤ | Outlet silencer |
| ② | Inlet silencer | ⑥ | Non-return flap (Option G1) |
| ③ | Belt guard | ⑦ | Safety relief valve |
| ④ | Blower block | ⑧ | Displays |

The drive motor (electric motor) ① drives the blower block ④ via a belt drive.

Air is drawn into the inlet silencer ② and through an air filter where it is cleaned.

The air is then pushed from the blower block in a vertical direction into the outlet silencer ⑤, where the process induces pressure build-up.

4.2 Blower block

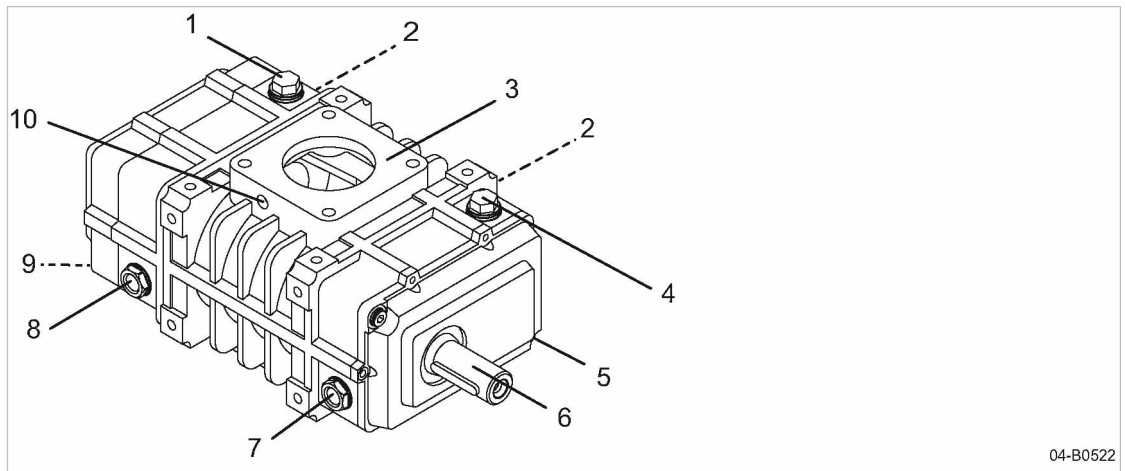

Fig. 9 Blower block

- | | | | |
|---|--------------------------------|---|--|
| ① | Gear-end oil inlet | ⑥ | Drive shaft |
| ② | Side gas drainage (closed) | ⑦ | Drive-end oil sight glass |
| ③ | Flange connection (both sides) | ⑧ | Gear-end oil sight glass |
| ④ | Drive-end oil inlet | ⑨ | Gear-end oil drain |
| ⑤ | Drive-end oil drain | ⑩ | Connection for measuring instrument (both sides) |

A pair of rotors with intermeshing lobes turn in opposite directions within a casing. The rotors are synchronized by timing gears on one end. Air in the block inlet is trapped between the rotor lobes and the casing and moved round to the discharge port.

As there is no contact between the rotors themselves and the casing, oil film lubrication is not required.

4.3 Safety relief valve

The safety relief valve protects the vacuum system from excessive vacuum. It is factory set.

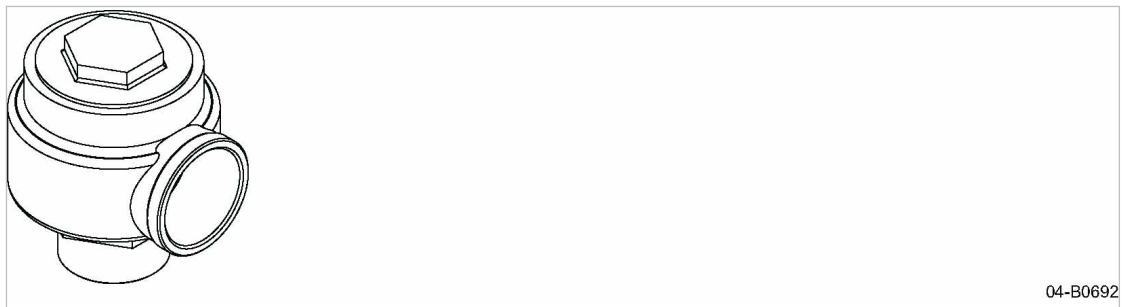

Fig. 10 Safety relief valve

4.4 Safety devices

The following safety devices are provided and may not be modified in any way:

- Safety relief valve:
This valve protects the vacuum system from excessive vacuum. It is factory set.

- Covers over moving parts and electrical connections:
These protect against accidental contact.
- Sound enclosure (Option H12):
The sound enclosure prevents excessive noise emission.
- Drive motor with 3 PTC thermistors:
Motor protection against overheating in connection with the user's protection cut-out.

4.5 Compensator

The compensator functions as follows:

- Inlet and outlet side connection to silencers and accessories
- Isolates the machine vibrations from the pipeline

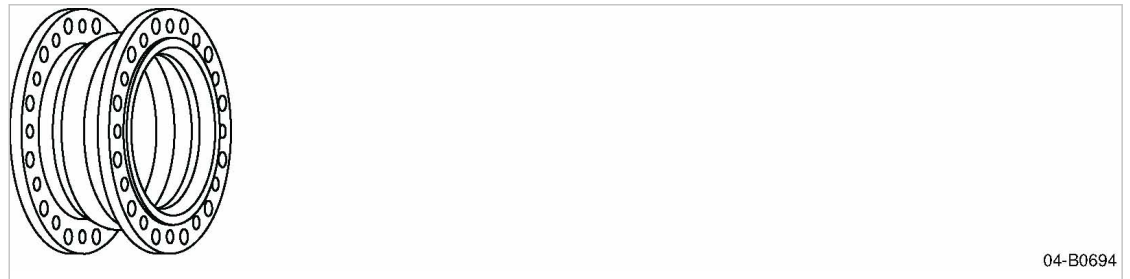

04-B0694

Fig. 11 Compensator

4.6 Pressure gauge

The pressure gauge shows the pressure in the blower block's inlet port.

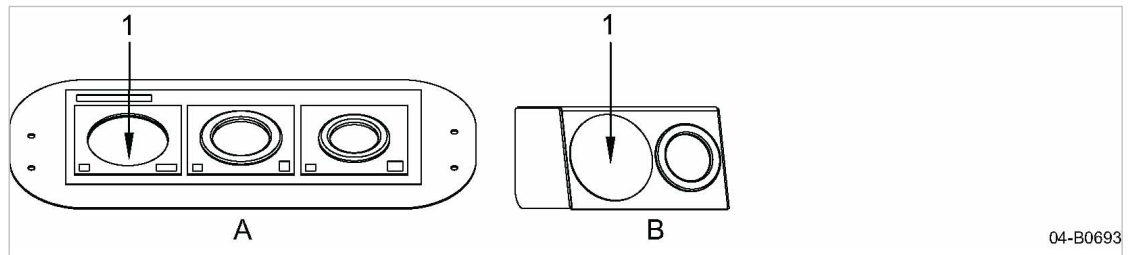

04-B0693

Fig. 12 Location of the pressure gauge

- (A) Machine with sound enclosure
- (B) Machine without sound enclosure
- (1) Pressure display

4.7 Floating relay contacts

Potential-free contacts for the transmission of messages are provided.

For information on location, loading capacity, and message type please see electrical wiring diagrams options in Chapter 13.5.



If the floating relay contacts are connected to an external voltage source, voltage may be present even when the machine is isolated from the power supply.

4.8 Options

The options available for your machine are described below.

4.8.1 Option C5 Oil level monitor

This device monitors the level of lubricating oil in the blower block.

This electronic monitoring does not relieve the obligation to make regular manual checks of the oil level.

Functional description

Two float-type level sensors monitor the level of oil in the drive and gear-end oil chambers. If the oil level falls below the minimum level, a switching contact is opened. The resulting signal is interpreted by external components provided by the user.

4.8.2 Option C9 Pressure switch

The pressure switch sends a signal when the set pressure is exceeded.



The pressure switch is factory set according to the customer's specification. In other cases it must be set according to the application.

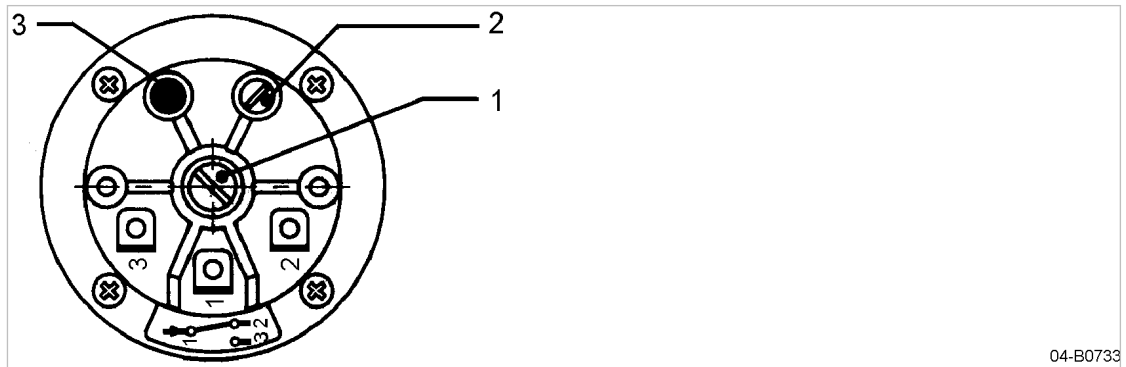

04-B0733

Fig. 13 Pressure switch

- ① Switching point adjusting screw
- ② Switching differential adjusting screw
- ③ Screw sealed with a protective coating

The switching point can be adjusted by the screw ① while the machine is running.

Fine adjustment and switching differential is set with the adjusting screw ②.



The screw ③ is sealed with a protective coating. It is not to be adjusted.

4.8.3 Option C10 Speed monitor

The speed monitor measures the rotational speed of the blower block.

4.8.4 Option C13 Temperature gauge switch

The gauge shows the temperature in the block discharge port and has a floating relay changeover contact that can be set to switch at a selected temperature.



The switching point is factory set to 293 °F.

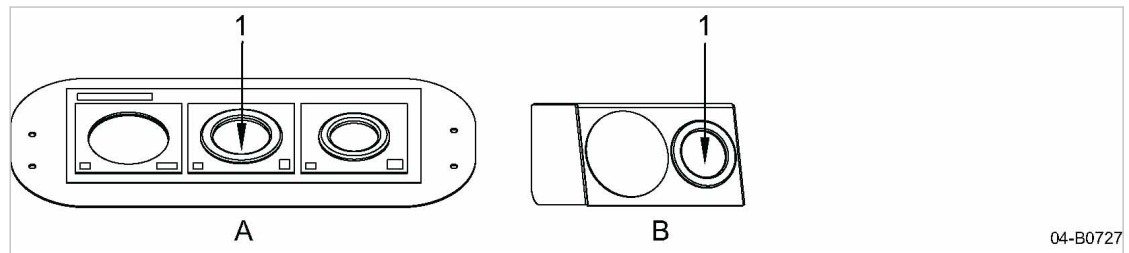

Fig. 14 Location of the temperature gauge

- (A)** Display: Machine with sound enclosure (Option H12)
- (B)** Display: Machine without sound enclosure
- (1)** Temperature gauge

Setting instructions

The switching point can be adjusted by means of the screw beneath the protective cover on the front plate.

Possible adjustment for working conditions on site:

- Block discharge temperature lower than 293 °F
 - If the average block discharge temperature is significantly lower than 293 °F, the gauge switching point can be adjusted down.
The recommended switching point is the average block discharge temperature plus +15 K.
- Block discharge temperature higher than 293 °F
 - If the average block discharge temperature is near to or higher than 293 °F, adjust the switching point upward.
The maximum permissible value is 311 °F.

4.8.5 Option C14 Pressure sensor

The sensor measures the actual block discharge pressure.



04-B0734

Fig. 15 Pressure sensor

4.8.6 Option C19, H12 Thermostat

The thermostat controls the temperature within the sound enclosure. It consists of a temperature sensor with a floating relay change-over contact.



The switching point is factory set to 140°F.

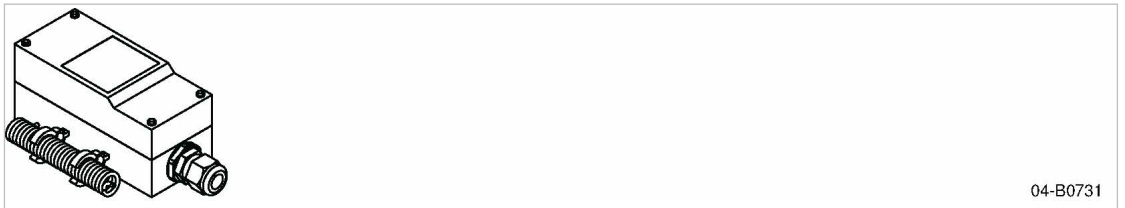

04-B0731

Fig. 16 Thermostat

4.8.7 Option F5 Filter pressure differential switch

The filter pressure differential switch monitors contamination of the intake filter.

The switch is triggered by pressure differential. Falling below or rising above the set value causes the current flow to switch on, switch off or changeover according to how the switch is wired.

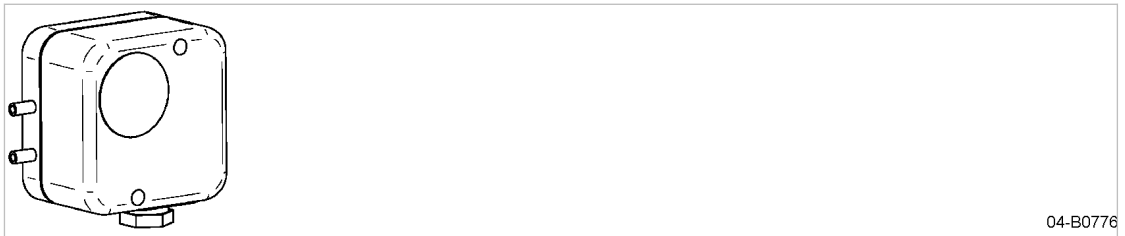

04-B0776

Fig. 17 Filter pressure differential switch

Pressure connection diagram

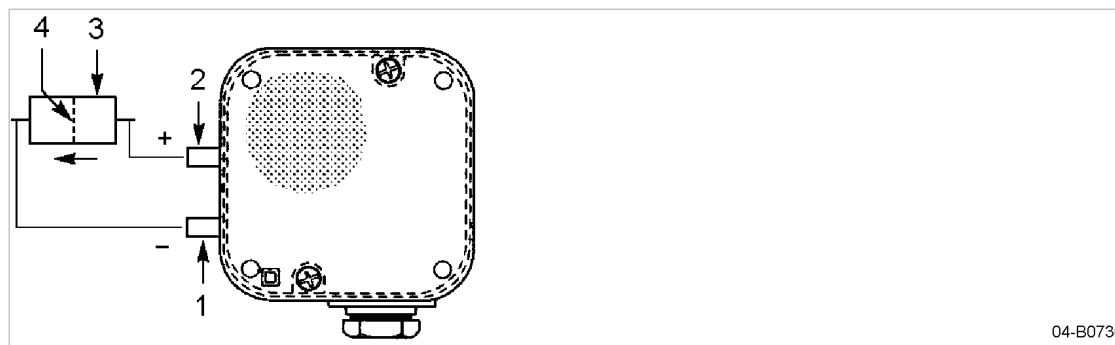

Fig. 18 Pressure connection to the filter pressure differential switch

- | | |
|------------------------------|------------------|
| ① Low pressure connection | ③ Inlet silencer |
| ② Higher pressure connection | ④ Filter |

Switching function

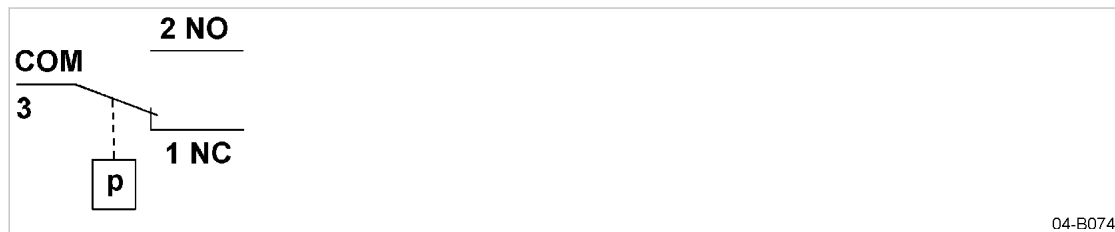

Fig. 19 Filter pressure differential switch function

Switching with rising pressure:

- 1 NC opens
- 2 NO closes

Switching with falling pressure:

- 1 NC closes
- 2 NO opens

4.8.8 Option G1
Check valve

The check valve prevents a reversal of the normal air flow direction.
The valve is closed when the machine is at standstill.

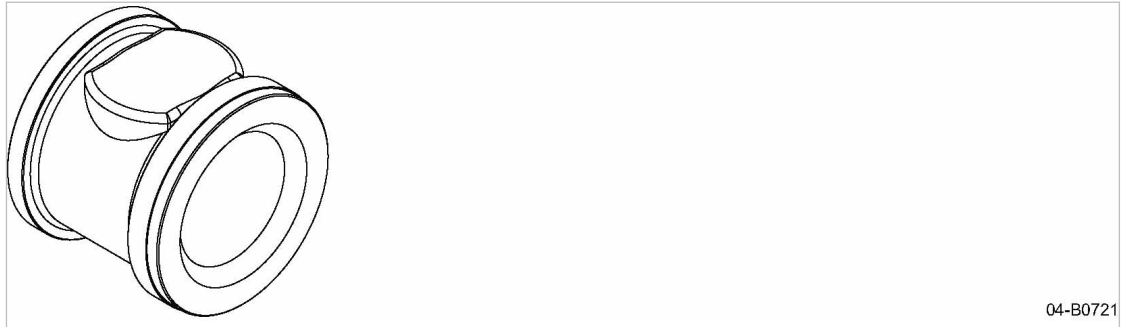

04-B0721

Fig. 20 Check valve

4.8.9 Option H2, H12 Auxiliary heating

The auxiliary heating has the following functions:

- Prevents condensation forming on the machine in climates of high humidity.
- Pre-warms the machine when ambient temperatures are below 23°F.

The auxiliary heating is designed to raise the machine temperature to about 50°F.



The thermostat switching point is factory set to 41°F.

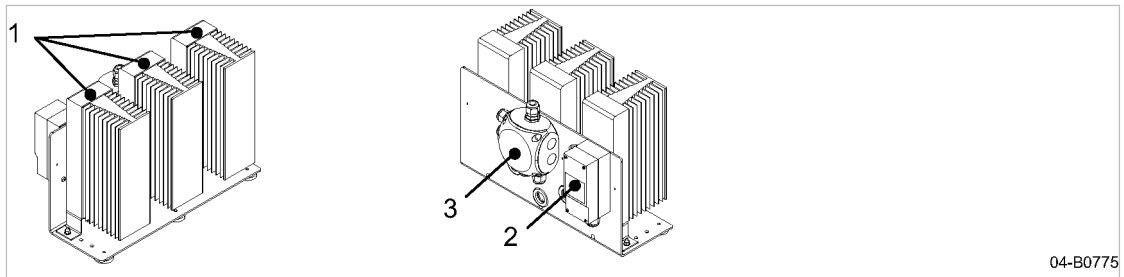

04-B0775

Fig. 21 Auxiliary heating

- ① Radiator
- ② Thermostat
- ③ Terminal box

4.8.10 Option H3, H12 Outdoor installation

The sound enclosure (Option H12) is fitted with a weather protection roof.

Should the machine be installed outdoors, the instruments and the parts of the sound enclosure within the cover area are protected against direct sunlight, rain, wind and snow.

Further information Information regarding the maximum permissible snow and wind loads can be found in chapter 2.14.10

4.8.11 Option H11 Piped inlet

Air is drawn into the block through the inlet silencer.

**4.8.12 Option H12
 Sound enclosure**

Fig. 22 Sound enclosure overview

- | | |
|----------------------|--------------------|
| ① Removable panels | ⑥ Display (option) |
| ② Side panel | ⑦ Air exhaust |
| ③ Cooling air inlet | ⑧ Back plate |
| ④ Intake air inlet | ⑨ Frame |
| ⑤ Cooling air outlet | ⑩ Flip panels |

The sound enclosure has removable panels ① and the flip panels ⑩ can be opened. Latches are released by a key supplied with the machine.

The sound enclosure has several functions when it is closed:

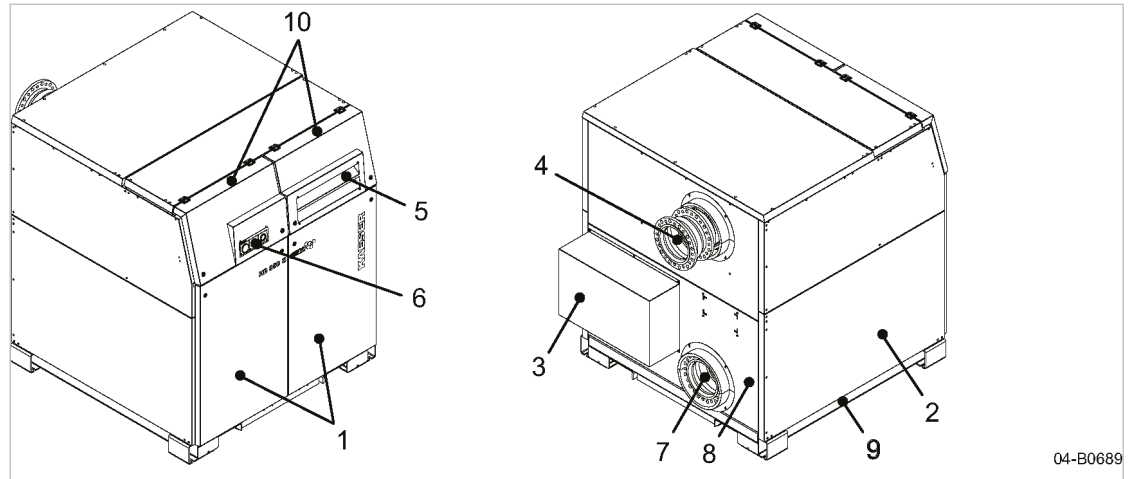
- Sound insulation
- Protection against contact with components
- Airflow control

The sound enclosure is not suitable for the following uses:

- Persons walking, standing or sitting on the machine.
- Use as a resting place or storage of any kind of load.

Process air flow

Air is drawn from the suction line into the blower block through the inlet silencer.

Air is discharged from the block through the air exhaust ⑦.

Cooling air flow

The drive motor fan draws cooling air through the cooling air inlet ③ into the sound enclosure to cool the drive motor and the blower.

Cooling air flow is supplemented by a fan within the enclosure. Warm air is blown out to protect the machine from overheating.

4.8.13 Option H16, H12
Exhaust silencer (pipeline)

The exhaust silencer reduces noise emission.

⚠ WARNING

Danger of burns from hot components!

- *Wear long-sleeved clothing and protective gloves.*

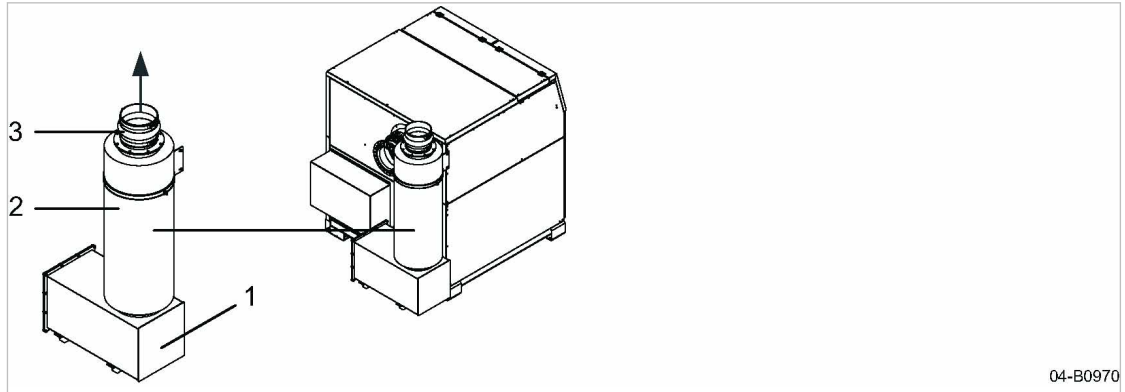

04-B0970

Fig. 23 Exhaust silencer (pipeline)

- ① Deflection box
- ② Silencer
- ③ Compensator
(connection to pipeline)

Warm process air passes out through a compensator ③ of the silencer ② into a flexible pipeline. The exhaust air can reach temperatures up to max. 320°F in the silencer.

4.8.14 Option H19, H12
Exhaust silencer (diffusion to surroundings)

The exhaust silencer reduces noise emission.

⚠ WARNING

Danger of burning from hot components and scalding from escaping oil.

- *Wear long-sleeved clothing and protective gloves.*
- *Do not breath in the discharge air.*

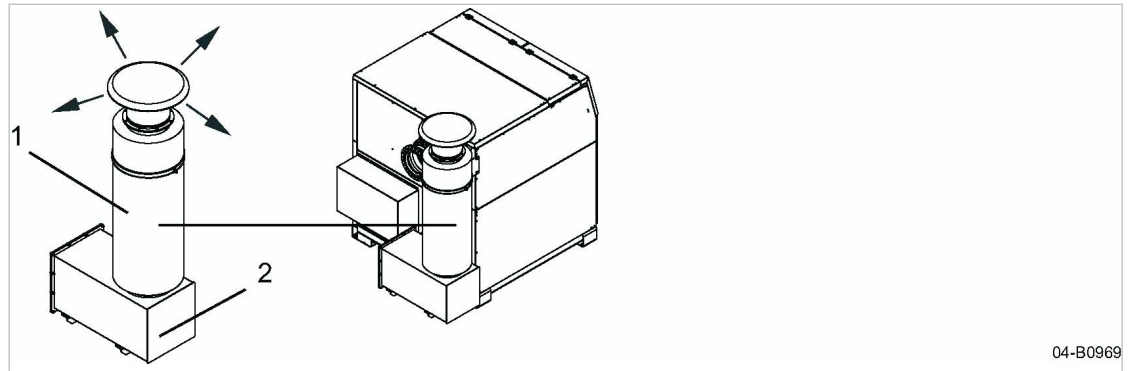

Fig. 24 Exhaust silencer (diffusion to surroundings)

- ① Silencer
- ② Deflection box

Exhaust process air is diffusely blown out through the silencer ① into the surrounding atmosphere. The exhaust air may reach temperatures up to max. 320°F.

5 Installation and Operating Conditions

5.1 Ensuring safety

The conditions in which the machine is installed and operated have a decisive impact on safety. Warning instructions are located before a potentially dangerous task.



Disregard of warning instructions can cause serious injuries!

Complying with safety instructions

Disregard of safety warnings can cause unforeseeable dangers!

- Strictly forbid fire, open flame and smoking.
- If welding is carried out on or near the machine, take adequate measures to prevent sparks or heat from igniting oil vapors or parts of the machine.
- Do not store flammable material in the vicinity of the machine.
- The machine is not explosion-proof!
Do not operate in areas in which specific requirements with regard to explosion protection are in force.
- Ensure sufficient and suitable lighting such that the display can be read and work carried out comfortably and safely.
- Keep suitable fire extinguishing agents ready for use.
- Comply with the permissible ambient and intake conditions.
- Ensure the correct composition of the intake air:
 - Clean with no damaging contaminants (e.g., dust, fibers, fine sand).
 - Free of explosive or chemically unstable gases or vapors.
 - Free of acid/alkaline forming substances, particularly ammonia, chlorine or hydrogen sulfide.

Noise

The sound enclosure absorbs and reduces the machine noise to a comfortable level. This function will be effective only if the sound enclosure is closed.

- If necessary, wear hearing protection or take hearing protection measures on-site.

5.2 Installation conditions

5.2.1 Determining location and clearances

The machine is intended for installation in an appropriate machine room. Information on distances from walls and ventilation is given below.



The distances quoted are recommended distances and ensure unhindered access to all machine parts.

- Please consult an authorized KAESER service representative if you cannot comply with these recommendations.

Precondition The floor must be level, firm, and capable of bearing the weight of the machine. No special foundation is necessary.

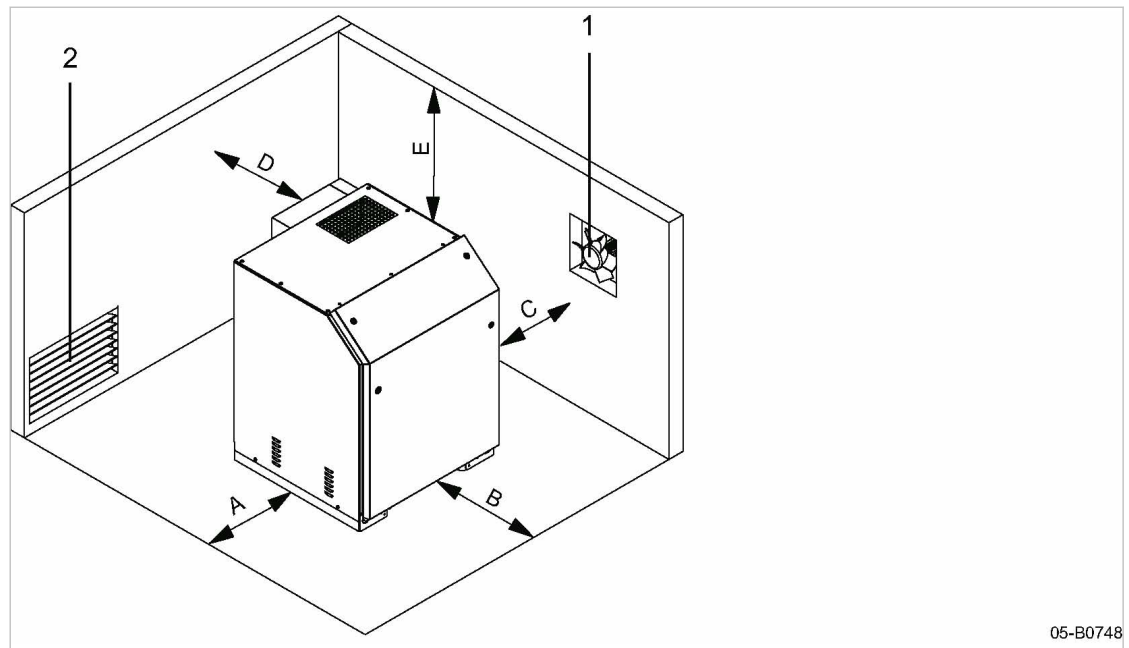

Fig. 25 Recommended machine placement and minimum dimensions [in.]

| | | | |
|------------|-------------|------------|--------------------|
| (A) | 2.4 or 27.6 | (E) | 32.0 |
| (B) | 39.4 | (1) | Exhaust fan |
| (C) | 2.4 or 27.6 | (2) | Air inlet aperture |
| (D) | 39.4 | | |

- The distance **(A)** or **(C)** must be at least 27.6 in.
Version 1: A = 2.4 in. and C = 27.6 in.
Version 2: A = 27.6 in. and C = 2.4 in.
- If the ambient temperature is too low: Heat the machine room adequately or install an auxiliary heater.
- Ensure accessibility so that all work on the machine can be carried out without danger or hindrance.
- Do not position the machine in the warm exhaust air flow from other machines.
- When installing multiple machines, ensure that all intake and exhaust air openings are arranged at one side.
- If installed outdoors, protect the machine against frost, direct sunlight, dust, and rain.

5.2.2 Ensuring adequate ventilation



If the ventilation is insufficient, a partial vacuum can be created in the room.

- Ensure that the volume of air flowing into the machine room is at least equivalent to that being removed from it by the machine and exhaust fan.
- Make sure that a sufficient amount of oxygen is supplied to individuals in the machine room.
- Make sure that the machine and exhaust fan can only operate when the inlet aperture is actually open.
- Keep the inlet and exhaust apertures free of obstructions so that the cooling air can flow freely through the room.
- Ensure clean air in order to support the proper functioning of the machine.

5.3 Option H3, H12 Outdoor installation

The sound enclosure (Option H12) is fitted with a stainless steel weather protection roof.

As per DIN EN ISO 129442, sound enclosure parts are painted in accordance with corrosion category C3 and a medium protection period (m).

Should the machine be installed outdoors, the instruments and the parts of the sound enclosure within the cover area are protected against direct sunlight, rain, wind and snow.

1. **⚠ CAUTION** *Risk of accident from falling snow and/or ice loads!*
 - *Remove any snow and/or ice from the machine before commissioning*
2. Remove snow and/or ice with caution.

6 Installation

6.1 Ensuring safety

Follow these instructions to ensure safe installation.

Warning instructions are provided prior to any potentially dangerous task.



Disregarding warning instructions can result in life-threatening injuries!

Observing safety instructions

Ignoring safety instructions can result in unforeseen dangers.

- Follow the instructions in chapter 3 “Safety and Responsibility”.
- Installation work must only be carried out by authorized personnel!
- Ensure that no personnel are working on the machine.
- Ensure that all cover panels are closed.

Working on live components

Touching live components can result in electric shocks, burns or death.

- Work on electrical equipment may only be carried out by authorized electricians.
- Switch off the power supply disconnecting device (all poles), lock out and tag out the device, verify the absence of any voltage.
- Check that there is no voltage on floating contacts.

Working at the vacuum system

The following safety instructions relate to any work on components that could be under pressure.

- Switch off the power supply disconnecting device (all poles), lock out and tag out the device, verify the absence of any voltage.
- Vent all components and chambers under vacuum to atmospheric pressure.
- Do not open or dismantle any valves.

Working on the drive system

Touching live components can result in electric shocks, burns or death.

Touching the fan wheel or the belt drive while the machine is running can result in serious injury.

- Switch off the power supply disconnecting device (all poles), lock out and tag out the device, verify the absence of any voltage.
- Do not open any of the cover panels while the machine is switched on.
- If full protection is only provided when the machine is completely installed, then in all other phases of the machine's life-cycle temporary protective devices (e.g. covers) must be fitted, in order to guarantee that parts of the body cannot reach or be caught/sucked in by the rotary lobes.

Further information

Information regarding authorized personnel can be found in chapter 3.4.2.

Information regarding dangers and their avoidance can be found in chapter 3.5.

6.2 Reporting transport damage

1. Check the machine for visible and hidden transport damage.
2. Inform the carrier and the manufacturer in writing of any damage without delay.

6.3 Anchoring the machine

The machine may be anchored to the floor.

The following anchoring elements are shipped with the machine:

Foundation bolts for machines without sound enclosure.

Foundation bolts and angle brackets for machines with sound enclosure.

- Use the anchoring elements to anchor the machine without stress.

Further information Details of the fixing holes are contained in the dimensional drawing in chapter 13.2.

6.4 Do not remove or change the adjusting screw of the pivoted motor base

The hex-head bolt that presses against the pivoted motor base from the side serves as an adjusting screw for the fine adjustment of the belt alignment. A gap between the hex-head bolt and the pivoted motor base ensures the clearance in radial direction and forms the stop in axial direction.

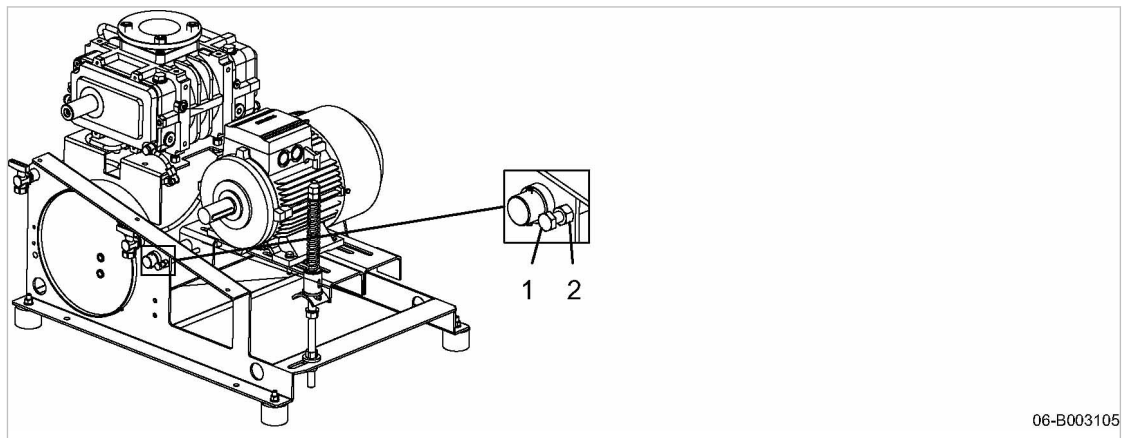

Fig. 26 Pivoted motor base

- ① Adjusting screw
- ② Hex nut

- Do **not** remove or change the adjusting screw ① and corresponding hex nut ②.
- Contact an authorized KAESER service representative with any questions regarding the alignment of the belt drive.

6.5 Connecting the machine to the power supply

Precondition The power supply disconnecting device is switched off, lock out and tag out the device, the absence of any voltage has been verified.

The tolerance limits of the power supply are within the permissible tolerance limits of the rated machine voltage.

Option C32, operation under frequency control: The voltage in the intermediate circuit capacitors of the frequency converter is reduced.

1. The power supply must only be connected by authorized installation personnel or an authorized electrician.
2. Carry out safety measures as stipulated in relevant regulations and in national accident prevention regulations. In addition, observe the regulations of the local electricity supplier.
3. Select supply cable conductor cross sections and fusing in accordance with machine power and as per local regulations.
4. Test the overcurrent protective device to ensure that the time it takes to shut down in response to a fault is within the permitted limit.
5. The user is required to fit the machine with a lockable power supply disconnecting device which must comply with the requirements of EN 60204-1: 2018. 5.3.
This could be, for example, a load disconnect switch with fused input. If a circuit breaker is used it must be suitable for the motor starting characteristics.
6. Connect the drive motor to the power supply in accordance with the applicable connection diagram.
See connection diagram in chapter 13.4.
7. The user's safety devices must be correctly connected to the machine's electrical system by a qualified person.
8. Option C32, operation with frequency converter: Please refer to - and observe - all documentation regarding operation of, and work on, the frequency converter.
9. **⚠ DANGER** *Danger of fatal injury from electric shock!*
 - *Switch off and lock out/tag out the power supply disconnecting device and verify the absence of voltage.*
 - *When working with the frequency converter: Wait at least 5 minutes for dangerous voltages to subside.*
10. Connect the machine to the power supply.
11. Properly close openings, cable glands, etc.



The machine can be operated at full power at the rated voltage with a tolerance of $\pm 5\%$.

6.5.1 Option C32 For frequency control



If the machine delivered by KAESER includes the frequency converter, the regulation behavior and operating mode of the frequency converter will be preset.

- Adapt and optimize the actual properties to the customer system on-site.

Comply with the following provisions if you operate machines with a frequency converter:

- Operate the machine only within its performance limits and under the permitted ambient conditions.

- The frequency converter must be suitable for the operation of a working machine with constant torque. Models with squared torque may not be used.
- Drive motor rated power ≤ 75 hp:
To avoid bearing damage at the drive motor, install components for magnetic shielding at the frequency converter's phase wire output ends (e.g., rings with high permeability).
- When operating the machine with frequency converter, the drive motor must be designed as follows:
 - Voltage < 500 V ≥ 100 hp:
Standard winding and isolated bearing or bearing shield at the control side, regardless of the model.
 - Voltage ≥ 500 V < 100 hp:
Enhanced winding isolation, standard bearing, regardless of the model.
 - Voltage ≥ 500 V ≥ 100 hp:
Enhanced winding isolation and isolated bearing or bearing shield at the drive and the control side, regardless of the model.
- Frequency converters providing a lower initial voltage than the rated motor voltage will cause an increased power consumption and heat development in the drive motor. This results in a reduced nominal motor power that can be utilized and thus a decrease in the machine's regulating range. To avoid damage to the drive motor, please consult with the manufacturer of the frequency converter.
- Use a frequency converter with IGBT transistors.
- The speed change should be approx. 5 Hz per second. This value applies also for the starting ramp from standstill to reaching minimum frequency. Changing the settings, either slower or faster, may be possible after verification by an authorized KAESER service representative.
- The frequency converter may be switched onto a motor in standstill only, in order to avoid malfunctions.
- Upon deactivation of the frequency converter, it must be impossible to reactivate it until after complete machine standstill.
- For a shut-down in the event of a malfunction, integrate the following devices in the user's controller:
 - PTC resistor for monitoring the winding temperature of the drive motor.
 - Thermostat for monitoring the blower block discharge temperature.
- For safety-technical reasons, an automatic restart of the machine is not permitted and must be fully deactivated when parametrizing the frequency converter.
- The maximum conductor length between the output of the frequency converter and drive motor is 98 ft. Longer conductors may be possible upon verification by an authorized KAESER service representative.
- Only shielded conductors may be used to connect the machine to ensure an EMC compliant connection and machine operation.
 - Do not twist the braided shield of these conductors. The braided shield must be generously spread two-sided across the ground potential.
 - Use only EMC shield clamps or EMC-compliant screwed cable glands.
 - This also applies to other connecting cables, such as the thermistor sensors (PTC) of the drive motor.

Further information Consult with an authorized KAESER service representative to determine an appropriate frequency converter.

**6.5.2 Option H3, H12
Outdoor installation**

- Install suitable protection against lightning.

6.6 Connecting to the vacuum network

Material Torque wrench

Precondition The vacuum network is ventilated.



A non-return valve or check valves must be installed in systems that are to remain under vacuum when the machine is shut down.

- Consult KAESER regarding a suitable check valve and expert installation.
1. Create a vacuum connection with compensator or flexible hose line and install with the following torques:

| Connection to customer's piping | Torque [lbf-ft] |
|------------------------------------|-----------------|
| Compressor with hose clamps | — |
| Compressor with screwed joint M20* | 66.4 |

* Manually tighten screws equally, pretension crosswise at 37 lbf-ft and subsequently retighten crosswise with torque according to table.

Tab. 29 Compensator torques

2. Support the weight of the pipework and any other connecting components.
3. Install a suitable pipeline to lead discharge air outdoors.

Option H12 Sound enclosure

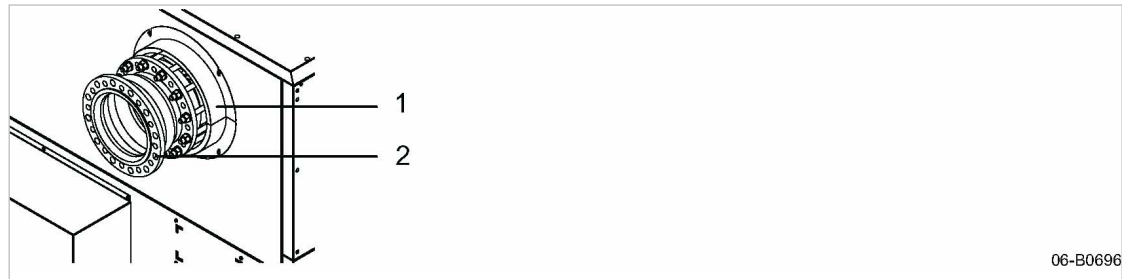

Fig. 27 Assembling the two collar halves

- ① Collar half
- ② Compensator

- Tightly position the supplied collar halves ① around the compensator ② of the port ends and screw to the sound enclosure.

Further information The dimensional drawing in chapter 13.2 provides information regarding the connection of the piping.

6.7 Safety devices installed by the user

- The user must install the necessary safety devices.
 - Three PTC thermistor sensors should be installed by the user to protect against drive motor overheating or overloading.
 - A motor overload protection switch/overload relay (if not included with the deliverables) must be installed to monitor maximum current draw(s).
 - EMERGENCY OFF command device for immediate shut-down of the machine.
- The user must monitor the following parameters:
 - Permissible final pressure
 - Maximum block discharge temperature
- Consult KAESER for advice on this subject.



Safety valves and check valves are not regulating means in case of overpressure. The activation of the safety relief valve (blow-off valve) constitutes an impermissible operating state requiring immediate remedial measures.

6.8 Options

All options are mechanically installed/mounted. The electrical connections and evaluations are the customer's responsibility.

- Read and follow instructions on individual options!

6.8.1 Option C5 Connecting the oil level monitor

- Connecting the oil level monitor.

Further information See electrical diagram in chapter 13.5.1.

6.8.2 Option C9 Connecting the pressure switch

- Connecting the pressure switch

Further information See chapter 13.5.2.

6.8.3 Option C10 Connecting the speed monitor

The sensor and transmitter are mechanically installed.

- A speed monitor sensor is supplied separately when ordered individually. Install in the user's control cabinet and wire up.

Further information See chapter 2.14.3 for the sensor settings.
The wiring diagram for the speed monitor is found in chapter 13.5.3.

6.8.4 Option C13

Connecting the temperature gauge switch

- Connect the temperature gauge switch.

Further information See electrical diagram in chapter 13.5.4.

6.8.5 Option C14

Connecting the pressure sensor

- Connecting the pressure sensor

Further information See chapter 13.5.5.

6.8.6 Option C19

Connecting the thermostat

- Connect the thermostat.

Further information See electrical diagram in chapter 13.5.6.

6.8.7 Option F5

Connecting the filter pressure differential switch

- Connect the filter pressure differential switch.

Further information See electrical diagram in chapter 13.5.7.

6.8.8 Option H2

Connecting the auxiliary heater

- The auxiliary heater is delivered uninstalled. The radiator, thermostat, and terminal box are already installed on a mounting plate.
- Connect the auxiliary heater in the terminal box.

Further information See the electrical diagram in chapter 13.5.8.

6.8.9 Option H12

Sound enclosure

6.8.9.1 Electrical connections

Subsequent work enables the access to the electrical connections of drive motor, extractor motor and accessories.

1. Remove the panel of the sound enclosure and open the flaps, if necessary. Latches are released by a key supplied with the machine.
2. Make the electrical connections.
3. Replace the panel and close the flaps, secure the latches.

6.8.9.2 Connecting the extractor

The extractor motor has a terminal box for direct supply connection.

The drive motor and the extractor must run simultaneously.

Ensure correct direction of rotation when connecting the extractor motor. The extractor must blow air out of the sound enclosure.

The extractor should run on for approx. 15 minutes after machine shut down to avoid temperature peaks inside the sound enclosure.

Precondition The power supply is switched off,
the device is locked off,
the absence of any voltage has been verified.

1. Select sufficient cable length.
2. Connect cables to the terminal box without mechanical stress.
3. Connect the protective ground.

Further information See electrical diagram in chapter 13.5.9.

7 Initial Start-up

7.1 Ensuring safety

This chapter provides instructions for safe commissioning of the machine. Warning instructions are provided prior to any potentially dangerous task.



Disregarding warning instructions can result in life-threatening injuries!

Observing safety instructions

Ignoring safety instructions can result in unforeseen dangers.

- Follow the instructions in chapter 3 “Safety and Responsibility”.
- Commissioning tasks may only be carried out by authorized installation personnel!
- Ensure that no personnel are working on the machine.
- Ensure that all cover panels are closed.

Working on live components

Touching live components can result in electric shocks, burns or death.

- Work on electrical equipment may only be carried out by authorized electricians.
- Switch off the power supply disconnecting device (all poles), lock out and tag out the device, verify the absence of any voltage.
- Check that there is no voltage on floating contacts.

Working at the vacuum system

The following safety instructions relate to any work on components that could be under pressure.

- Switch off the power supply disconnecting device (all poles), lock out and tag out the device, verify the absence of any voltage.
- Vent all components and chambers under vacuum to atmospheric pressure.
- Do not open or dismantle any valves.

Working on the drive system

Touching live components can result in electric shocks, burns or death.

Touching the fan wheel or the belt drive while the machine is running can result in serious injury.

- Switch off the power supply disconnecting device (all poles), lock out and tag out the device, verify the absence of any voltage.
- Do not open any of the cover panels while the machine is switched on.
- If full protection is only provided when the machine is completely installed, then in all other phases of the machine’s life-cycle temporary protective devices (e.g. covers) must be fitted, in order to guarantee that parts of the body cannot reach or be caught/sucked in by the rotary lobes.

Further information

Information regarding authorized personnel can be found in chapter 3.4.2.

Information regarding dangers and their avoidance can be found in chapter 3.5.

7.2 Instructions to be observed before commissioning

Incorrect or improper commissioning can cause injury to persons and damage to the machine.

- Commissioning may be carried out only by authorized installation and service personnel who have been trained on this machine.

Special measures for recommissioning after storage/standstill

| Storage period/ standstill longer than | Measure |
|--|---|
| 12 months | <ul style="list-style-type: none"> ➤ Change the lubricating oil. ➤ Re-grease the drive motor bearings if they are not of the permanently-greased type. ➤ Check the condition and tension of the drive belts. ➤ Have the frequency converter smoothing capacitors formed (refreshed) by an authorized KAESER service representative. |
| 36 months | <ul style="list-style-type: none"> ➤ Have the overall technical condition checked by an authorized KAESER service representative. |

Tab. 30 Recommissioning after storage/standstill

7.3 Checking installation and operating conditions

- Check and confirm all the items on the checklist before commissioning the machine.

| Check: | See chapter | Confirmed? |
|--|-------------|------------|
| ➤ Have all packing materials, tools and transport securing devices been removed from the machine? | – | |
| ➤ Are the operators completely familiar with the applicable safety regulations? | – | |
| ➤ Have all of the installation conditions been fulfilled? | 5 | |
| For installation outdoors (Option H3/H12): | – | |
| ➤ Has all snow and/or ice been removed from the machine? | | |
| ➤ Has protection against lightning been installed? | | |
| ➤ Has an automatic shutdown feature for the event of a fault been installed via user-end safety devices? | 6.7 | |
| ➤ Are the cable cross-sections and fuse ratings sufficient? | 2.13 | |
| ➤ Has the drive motor electrical connection been checked? | 6.5 | |
| ➤ Has the fan (sound enclosure) electrical connection been checked? (Option H12) | 6.8.9 | |
| ➤ Has the direction of rotation for the drive motor and fan (sound enclosure) been checked? | 7.5 | |
| ➤ Have all electrical connections been checked for tightness? (Following initial commissioning, the check must be repeated after 50 operating hours) | – | |

7 Initial Start-up

7.4 Re-greasing the motor bearings

| Check: | See chapter | Confirmed? |
|--|-------------|------------|
| <ul style="list-style-type: none"> ➤ Is there adequate lubrication at the control-end and drive-end of the blower block? (Oil level in the center of the oil sight glass) | 10.5 | |
| <ul style="list-style-type: none"> ➤ Has the connection to the vacuum network been established with a flexible pressure line or compensator? | 6.6 | |
| <ul style="list-style-type: none"> ➤ Has the drive belt tension been checked? (Following initial commissioning, the check must be repeated after 24 operating hours) | 10.4 | |
| <ul style="list-style-type: none"> ➤ Is the machine firmly anchored to the floor without stress? | 6.3 | |
| <ul style="list-style-type: none"> ➤ Have the removable access panel for the sound enclosure and all other cover panels been fitted and locked in place? (Option H12) | 4.8.12 | |

Tab. 31 Installation conditions checklist

7.4 Re-greasing the motor bearings

- The motor bearings of motors with re-greasing facility must be re-greased with bearing grease prior to the initial commissioning of the machine.

Further information Further information on re-greasing motor bearings can be found in chapter 10.10.1.

7.5 Checking the direction of rotation for the drive motor

The machine is designed for a clockwise phase sequence.

Should the direction of rotation for the drive motor be wrong, the direction of flow through the machine will be reversed and pressure will rise in the inlet pipe.

An arrow indicating the direction of rotation is fixed on the side of the blower block at the drive end and at the belt guard.

Material Phase sequence indicator

NOTICE

- Wrong direction of rotation!
Can result in machine damage from excessive pressure.*
- *Ensure the correct direction of rotation.*

1. Remove the filter maintenance cover from the inlet silencer or inlet filter and/or remove the check valve on the inlet side.
2. Verify the direction of rotation using a phase sequence indicator on the machine supply lines.
3. If the direction of rotation is incorrect, exchange phases L1 and L2 of the supply lines.



If you do not have access to a phase sequence indicator:

- Arrange for the phase sequence to be checked by an authorized KAESER service representative.

**7.5.1 Option H12
Fan (sound enclosure)**

An arrow is also to be found on the fan to indicate its correct direction of rotation.

The fan must blow air out of the sound enclosure.

- **Single-phase fan:** If the direction of rotation is incorrect, switch the electric connection in the terminal box of the fan. Instructions regarding "Right" and "Left" operation are provided in the cover of the terminal box.
- **Three-phase fan:** If the direction of rotation is incorrect, interchange phases L1 and L2 of the supply line(s).

8 Operation

8.1 Switching the machine on and off

To a large extent, the procedure for switching the machine on and off depends on which operating mode is intended for the process and on the equipment provided for it. Such equipment is to be installed at the user-end and thus does not constitute part of the scope of supply for the machine (except in the case of options).



Information regarding the function of the user-end control cabinet should be taken from the documentation provided by the control cabinet manufacturer.

8.1.1 Switching on

- Ensure that the machine is in perfect technical condition before switching it on. If the machine is equipped with a sound enclosure, check that the fan is fully operational.
- Switch the machine on only when it is fully stopped.



Maximum frequency of motor starts per hour: 6 times.
Option C32, operation with frequency converter
Maximum frequency of motor starts per hour: unlimited.

Precondition A suitable unloaded start device is installed in case of back pressure.
No personnel are inside the machine.

1. **⚠ WARNING** *Serious injury can be caused by compressed air!*
 - *Ensure that no personnel are working on the machine.*
2. Switch the machine on via the user-end control cabinet or if Option C32, operation with frequency converter, is specified: switch the machine on at the frequency converter.
 - For installation outdoors (Option H3/H12): Remove snow and/or ice from the machine.
1. **⚠ CAUTION** *Risk of accident from falling snow and/or ice loads!*
 - *Remove any snow and/or ice from the machine before commissioning.*
2. Remove snow and/or ice with caution.

8.1.2 Switching off

- Switch the machine off via the user-end control cabinet or if Option C32, operation with frequency converter, is specified: switch the machine off at the frequency converter.

8.2 Switching off in an emergency

The machine is not equipped with an emergency stop device. Such a device must be provided by the user unless it is part of an ordered option.

- Ensure the machine can be stopped immediately in an emergency.

8.3 Option H12**Checking the ventilator fan function (sound enclosure)****NOTICE**

Overheating inside the sound enclosure!

A standstill of the ventilator can result in a breakdown of the blower block or other components.

- *If the ventilator stops, immediately provide an alternative flow of cooling air through the sound enclosure.*

- Check that air is actually being blown out of the enclosure cooling air outlet, e.g. by holding a sheet of paper in front of the outlet.

Further information KAESER SERVICE will advise on suitable measures.

9 Fault Recognition and Rectification

9.1 Basic instructions

The following tables are intended to assist in locating faults.

1. Do not attempt fault rectification measures other than those given in this manual!
2. In all other cases:
Have the fault rectified by an authorized KAESER service representative.

9.2 Faults

| Fault | Possible cause | Remedy |
|--|---|---|
| Unusual noise when running. | Too much backlash in the timing gears. | Call an authorized KAESER service representative. |
| | Too much play in the rotor bearings. | Call an authorized KAESER service representative. |
| | Rotors not synchronized. | Keep the pressure differential and speed as specified. Call an authorized KAESER service representative. |
| Blower block runs too hot. | Pressure differential too great. | Check and correct pressure differential. |
| | Clogged inlet filter reducing air intake volume. | Clean the inlet filter. |
| | Rotor clearance too large. | Call an authorized KAESER service representative. |
| | Leakage due to incorrect installation of pressure-bearing components. | Call an authorized KAESER service representative. |
| Oil leaks from the gas drain. | Oil level too high. | Drain off oil until the correct level is reached. |
| Oil leaking from around the drive shaft. | Shaft seal defective. | Call an authorized KAESER service representative. |
| Reduced air inlet flow. | Rotor clearance too large because of wear. | Call an authorized KAESER service representative. |
| | Intake resistance too high. | Clean the inlet filter. |

| Fault | Possible cause | Remedy |
|--------------------------------------|---|--|
| Black film on the oil sight glasses. | Oil not changed at the correct interval. | Change the lubricating oil. Clean or replace the sight glass. |
| | Insufficient oil. | Change the lubricating oil. Clean or replace the sight glass. |
| | Oil overheated. | Call an authorized KAESER service representative. |
| | Block overloaded. | Call an authorized KAESER service representative. |
| Water in the oil. | Condensate build-up by prolonged storage and high humidity. | Change the lubricating oil. |
| Safety relief valve activates. | Inappropriate operating state, operating pressure too high. | Bring the machine to a permissible operational state or shut down. |
| PTC relay trips out. | Operating pressure too high. | Check and correct pressure differential. |

Tab. 32 Faults and remedies

9.3 Options

This section provides remedies for technical faults concerning the machine's optional equipment.

9.3.1 Option H12 Sound enclosure faults

| Alarm | Possible cause | Remedy |
|---|---|--|
| Overheating inside the sound enclosure! | Fan defective or turning in the wrong direction. | Check connection. Contact an authorized KAESER service representative. |
| | Flow of cooling air blocked. | Check and clean cooling air apertures. Check the cooling air inlet temperature. |
| | Drive motor overloaded. | Check operating conditions. |
| | Leakage due to incorrect installation of pressure-bearing components. | Contact an authorized KAESER service representative. |

Tab. 33 Faults and remedies (option H12)

9.3.2 Option C14
Faulty pressure sensor

| Fault | Possible cause | Remedy |
|--|--|---|
| No output signal. | No power supply, broken wire. | Check power supply and wires. |
| | Pressure transducer incorrectly connected. | Check power supply and wires. |
| | No input pressure. | Check pressure feed. |
| | Electronic defect from power supply voltage surge or external voltage. | Call an authorized KAESER service representative. |
| Output signal does not respond to pressure changes. | Input channel blocked. | Clean the input channel and throttle screw, being careful not to damage the delicate diaphragm. |
| | Electronic defect from power supply voltage surge or external voltage. | Call an authorized KAESER service representative. |
| | Pressure transducer defective from mechanical overloading. | Call an authorized KAESER service representative. |
| Output signal too high and not responding to pressure changes. | Electronic defect from power supply voltage surge or external voltage. | Call an authorized KAESER service representative. |

Tab. 34 Faults and remedies (Option C14)

10 Maintenance

10.1 Ensuring safety

Follow the safety instructions below to ensure safe maintenance of the machine. Warning instructions are provided prior to any potentially dangerous task.



Disregarding warning instructions can result in life-threatening injuries!

Observing safety instructions

Ignoring safety instructions can result in unforeseen dangers.

- Follow the instructions in chapter 3 “Safety and Responsibility”.
- Allow maintenance work to be performed by authorized personnel only!
- Ensure that no personnel are working on the machine.
- Ensure that all cover panels are closed.

Working on live components

Touching live components can result in electric shocks, burns or death.

- Work on electrical equipment may only be carried out by authorized electricians.
- Switch off the power supply disconnecting device (all poles), lock out and tag out the device, verify the absence of any voltage.
- Check that there is no voltage on floating contacts.

Working at the vacuum system

The following safety instructions relate to any work on components that could be under pressure.

- Switch off the power supply disconnecting device (all poles), lock out and tag out the device, verify the absence of any voltage.
- Vent all components and chambers under vacuum to atmospheric pressure.
- Do not open or dismantle any valves.

Working on the drive system

Touching live components can result in electric shocks, burns or death.

Touching the fan wheel or the belt drive while the machine is running can result in serious injury.

- Switch off the power supply disconnecting device (all poles), lock out and tag out the device, verify the absence of any voltage.
- Do not open any of the cover panels while the machine is switched on.
- If full protection is only provided when the machine is completely installed, then in all other phases of the machine's life-cycle temporary protective devices (e.g. covers) must be fitted, in order to guarantee that parts of the body cannot reach or be caught/sucked in by the rotary lobes.

Further information

Information regarding authorized personnel can be found in chapter 3.4.2.

Information regarding dangers and their avoidance can be found in chapter 3.5.

10.2 Maintenance schedule

10.2.1 Logging maintenance work



The maintenance intervals given are those recommended for average operating conditions.

- Maintenance tasks should be carried out more frequently where operating conditions are unfavorable (e.g. dusty ambient) or when the equipment is in constant use.
- Adjust the maintenance intervals with regard to local installation and operating conditions.

- Keep a log of all maintenance and service work.

This enables the frequency of individual maintenance tasks and deviations from our recommendations to be determined.

Further information A prepared log is provided in chapter 10.12.

10.2.2 Regular maintenance tasks



The table below lists the required maintenance tasks.

If operating conditions are unfavorable (e.g. dusty ambient) or if the equipment is in constant use, maintenance tasks must be carried out more frequently (shorter intervals).

- Carry out maintenance tasks in a timely manner, taking the ambient and operating conditions into consideration:

| Interval | Maintenance task | See chapter |
|---|--|-------------|
| At least 24 hours after initial commissioning | Check drive belt tension. | 10.4 |
| At least 50 hours after initial commissioning | Check that all electrical connections are secure and properly attach if necessary. | – |
| 500 hours after initial commissioning* | Change the lubricating oil. | 10.7 |
| Up to 500 h Or monthly | Check the oil level. | 10.5 |
| | Check drive belt tension. | 10.4 |
| | Check the air filter. | 10.8 |
| Up to 1000 h | Clean the machine. | 10.9 |
| Up to 2000 h, At least once a year | Drive motor bearings with re-greasing facility: Re-grease the motor bearings | 10.10.1 |
| Up to 3000 h At least once a year | Change the FGB 220 lubricating oil. | 10.7 |
| Up to 3000 h, At least once a year | Change the air filter. | 10.8 |
| Annually | Check the safety relief valve. | 10.11 |
| | Check that all electrical connections are secure and attach if necessary. | – |

h = operating hours

* Not applicable in the case of initial commissioning by an authorized KAESER service representative.

| Interval | Maintenance task | See chapter |
|--|------------------------------------|-------------|
| Up to 6000 h, At least every 2 years | Change the SB 220 lubricating oil. | 10.7 |
| Up to 12000 h, At least every 4 years | Replace the drive belt. | 10.4 |

h = operating hours

* Not applicable in the case of initial commissioning by an authorized KAESER service representative.

Tab. 35 Regular maintenance tasks

10.2.3 Regular service tasks

The table below lists necessary service tasks.

- Only an authorized KAESER service representative should carry out service work.
- Have service tasks carried out punctually, taking the ambient and operating conditions into account:

| Interval | Service task |
|--|--|
| Up to 36000 h | Drive motor bearings with re-greasing fittings: Replace the motor bearings. |
| | (Option H12) Sound enclosure fan: Replace the fan. |
| Up to 36000 h, At least every 8 years | (Option G1) Maintain the check valve. Replace the compensators. |

h = operating hours

Tab. 36 Regular service tasks

10.3 Option H12 Sound enclosure

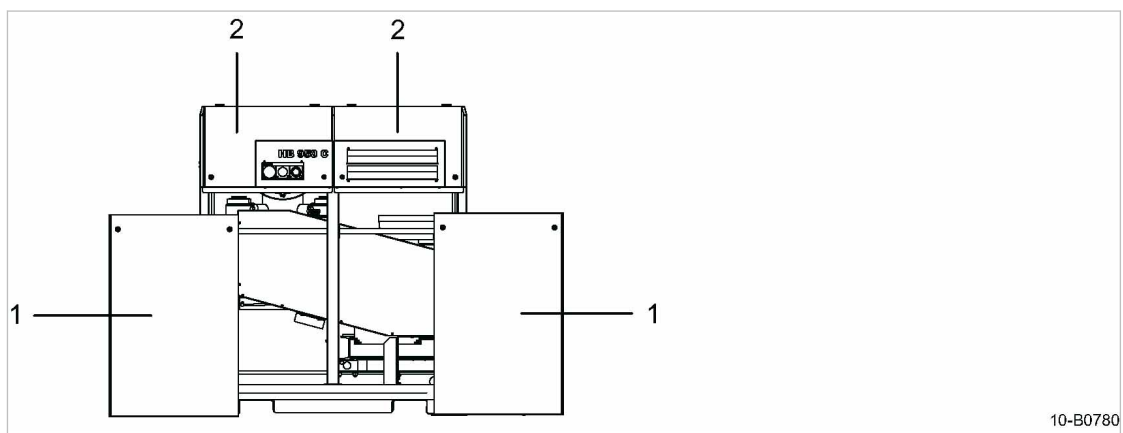

Fig. 28 Sound enclosure

- ① Removable panel
- ② Flap

- Lift off panel(s) ① for maintenance work.
- If required, open the flap(s) ②.
Latches are released by a key supplied with the machine.

10.4 Drive belt maintenance

Material Spare parts (if required)

Precondition The power supply disconnecting device is switched off, lock out and tag out the device, the absence of any voltage has been verified.
The machine has cooled down.

⚠ WARNING

Touching the moving drive belt may result in severe bruising or even loss of limb or extremities.

- *Switch off and lock out/tag out the power supply disconnecting device and verify the absence of voltage.*

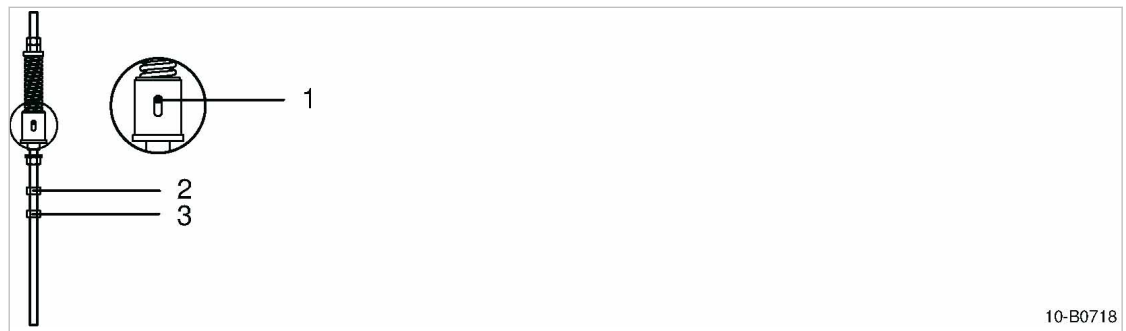

10-B0718

Fig. 29 Drive belt maintenance

- ① Marker pin (shown as: belt tensioning required)
- ② Locking nut
- ③ Adjusting nut

Checking belt tension and adjustment

The tensioning device uses spring force to apply correct tension to the belt.
Adjust the tension before the marker pin reaches the **top** end of the elongated hole.

1. Loosen the locking nut ②.
2. Use the adjusting nut ③ to adjust spring tension until the marker pin reaches the lower end of the elongated hole.
3. Tighten the locking nut ②.

Visually check for damages.

1. **⚠ CAUTION** *Danger of pinching between belt and pulley!*
➤ *Work carefully.*
2. Turn the pulley by hand so that the entire belt can be inspected for damage.
3. In case of damage: Replace the drive belt immediately.



When individual belts fail in multiple-groove drives, all belts must be replaced.

Changing the belt.

1. Remove the belt guard.
2. Loosen the locking nut ②.
3. Turn the adjusting nut ③ to loosen the tension on the belts until they can be removed from the pulley.
4. Install the new set of belts and use the adjusting nut ③ to adjust the tension until the marker pin reaches the lower end of the elongated hole.
5. Tighten the locking nut ②.
6. Replace the belt guard.
7. Check the tension after the new belt has been in operation for 50 hours.

10.5 Checking the oil level

The true oil level can be seen in the oil sight glass only when the machine is stopped.



The gear-end and drive-end oil chambers are not connected.

⚠ WARNING

Danger of burns from hot components!

- *Wear long-sleeved clothing and protective gloves.*

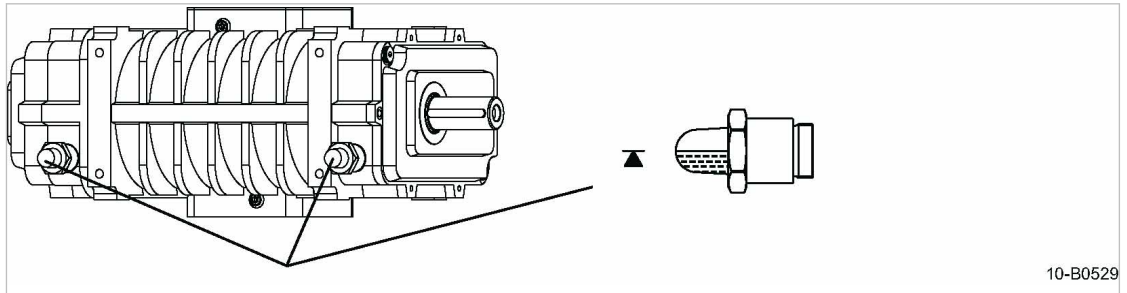

Fig. 30 Checking the oil level

1. Check the oil level in the sight glasses on both ends of the block.
2. Replenish as soon as the level falls 0.3 in. below the center of the sight glass.

10.6 Replenishing lubricating oil

Labels giving the oil type for replenishing can be found on the blower block and belt guard.



Prior to any work requiring an opening of the vacuum system, the machine must be fully vented to atmospheric pressure.

Precondition The power supply disconnecting device is switched off
The disconnecting device is locked in the off position.
The oil level has settled.

⚠ WARNING

Danger of burns from hot components and oil!

- *Wear long-sleeved clothing and protective gloves.*

NOTICE

Unsuitable oil can damage the block.

- *Never mix different types of oil.*
- *Never top off with a different type of oil than that already used in the blower block.*

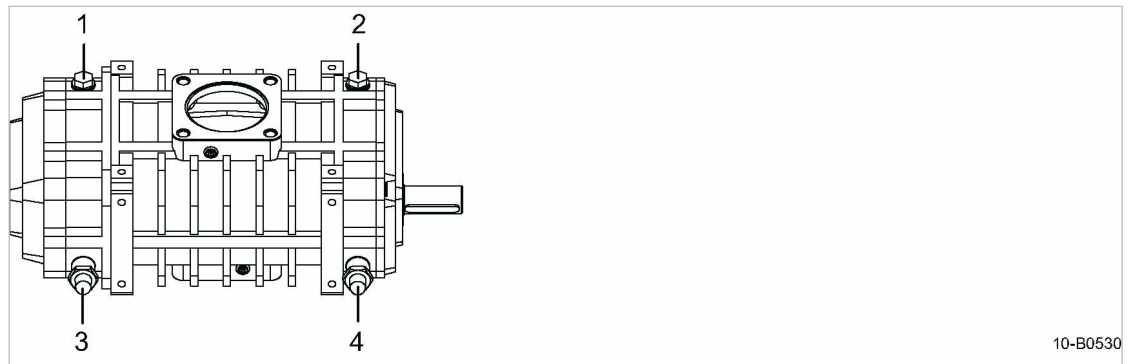

Fig. 31 Replenishing lubricating oil

- | | |
|---|---|
| <p>① Plug (oil filling port, control end)</p> <p>② Plug (oil filling port, drive end)</p> | <p>③ Control-end oil sight glass</p> <p>④ Drive-end oil sight glass</p> |
|---|---|

1. Slowly remove the plug ① and/or ②.
2. Top off until the level is at the marking on the sight glass ③ and/or ④.
3. Screw in the plugs.
4. Visually check for leaks.

10.7 Changing the oil



Prior to any work requiring an opening of the vacuum system, the machine must be fully vented to atmospheric pressure.

The oil should be changed with the block temperature at 130°F to ensure the oil flows freely.

Drain the oil thoroughly from the blower block:

- Control end
- Drive end

Material Lubricating oil
Oil receptacle

Precondition The power supply disconnecting device is switched off,
The device is locked off,
A check has been made that no voltage is present.

⚠ WARNING

Danger of burns from hot components and oil!

➤ *Wear long-sleeved clothing and protective gloves.*

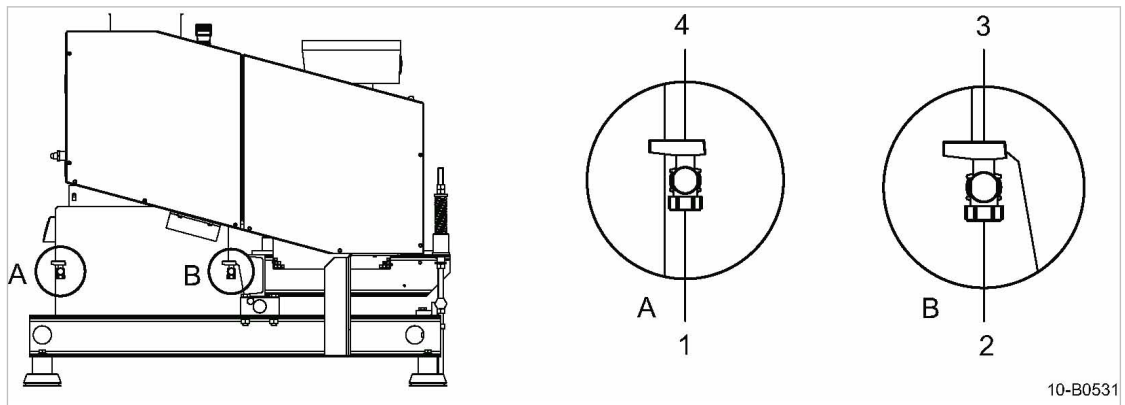

Fig. 32 Changing the oil

- | | | | |
|----------|-------------|----------|---------------|
| A | Drive end | 2 | Cap |
| B | Control end | 3 | Oil drain tap |
| 1 | Cap | 4 | Oil drain tap |

Draining the oil

1. Prepare an oil receptacle.
2. Open the filler plugs at the oil inlet of the blower block **1** and **2** (Fig. 31).
3. Take off the caps **1** and **2** and open the oil drain taps **3** and **4**.
4. Drain the lubricating oil.



Dispose of the old oil in accordance with local environmental protection regulations.

Filling with fresh oil

1. Fill with fresh oil.
2. Allow the oil drain taps to remain open until fresh oil begins to run out (bleeding the oil drain lines).
3. Close the oil drain taps **3** and **4**.
4. Check the oil level in both sight glasses (Fig. 31) and top off as necessary.
5. Screw on the caps **1** and **2**.
6. Replace and tighten the plugs of the oil inlets at the blower block.
7. Visually check for leaks.

10.8 Air filter maintenance

The air filter protects the vacuum system contained in the scope of delivery from ingress of dirt.

NOTICE

Machine damage caused by unsuitable air filter!

Dirt can enter the vacuum system and cause damage to the machine.

➤ *Use only genuine KAESER replacement air filters.*



The air filter cannot be cleaned.

10.8.1 Option F5 Filter pressure differential switch

The filter pressure differential switch monitors contamination of the intake filter.

The switch is triggered by pressure differential. Falling below or rising above the set value causes the current flow to switch on, switch off or changeover according to how the switch is wired.

➤ Change the air filter if the pressure differential switch activates.

10.8.2 Air filter maintenance



Prior to any work requiring an opening of the vacuum system, the machine must be fully vented to atmospheric pressure.

Material Spare parts

Precondition The power supply disconnecting device is switched off, the device is locked off, the absence of any voltage has been verified, the machine has cooled down.

⚠ WARNING

Danger of burns from hot components!

➤ *Wear long-sleeved clothing and gloves.*

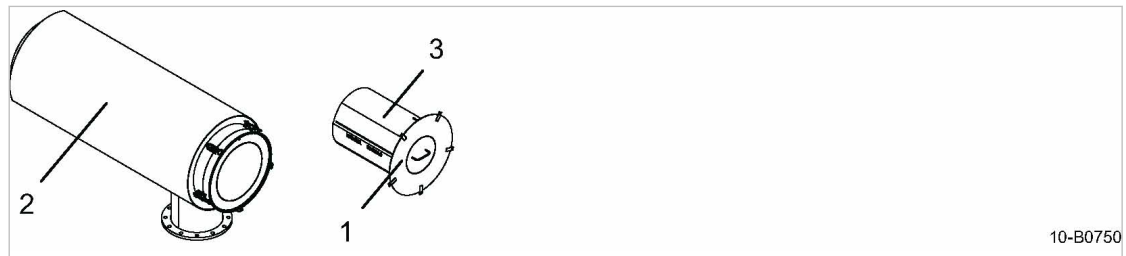



10-B0750

Fig. 33 Changing the air filter

- ① Cover
- ② Inlet silencer
- ③ Air filter

1. Open the snap fastener on the inlet silencer cover.

2. Take off the cover .
3. Loosen the Velcro strip and remove the air filter .
4. Clean all parts and sealing surfaces.
5. Place the new filter around the perforated inlet port and secure with the Velcro strip.
6. Attach the cover to the inlet silencer.

10.9 Machine cleaning

Regularly clean the machine. This ensures reliable cooling of the machine. The frequency is mainly dependent on local operating conditions.



Clogged machines are indicative of unfavorable ambient conditions. Such ambient conditions clog the cooling air ducts in the machine's interior and the motors resulting in increased wear and tear.

Material Brush and/or compressed air
Protective gloves
Face mask and safety goggles (if required)
Vacuum cleaner

Precondition The power supply disconnecting device is switched off,
the device is locked off,
the absence of any voltage has been verified.
The machine has cooled down.

1. Open the sound enclosure (Option H12).
Dismantle panels in order to clean the cooling air ducts of the drive motor.
2. Dry brush the machine or blow off with compressed air.
3. Vacuum off dirt.
4. Close sound enclosure (Option H12).
Replace and lock panels.



The machine cannot be cleaned?

- Have severe clogging removed by an authorized KAESER service representative.

10.10 Motor maintenance

Motor maintenance depends on the type of motor.

Material Grease gun with bearing grease UNIREX N3
Cleaning cloth

10.10.1 Drive motor bearings with re-greasing facility

The motor bearings are fitted with grease fittings.



Use only the high temperature grease UNIREX N3 for the motor bearings. Damage to bearings caused by the use of other brands of grease is excluded from the warranty.

The required quantity of grease is stated on the motor maintenance plate.

Precondition The motor is running.

1. **⚠ WARNING** *Noise during machine operation without sound enclosure or noise due to opened removable access panel of the sound enclosure (Option H12)! Hearing may be damaged.*
 - Always wear hearing protection.
2. **⚠ WARNING** *Danger of burns from hot components!*
 - Wear long-sleeved garments and protective gloves.
 - Work with caution.
3. **📌 NOTICE** *Drive motor damage due to incorrect re-greasing! If the motor is switched off, the new bearing grease is distributed incorrectly and pressed unused into the old grease tank.*
 - Re-grease the bearings only with the motor running.
4. The motor bearings must be replaced in the course of regular maintenance by an authorized KAESER service representative.

Machine without sound enclosure

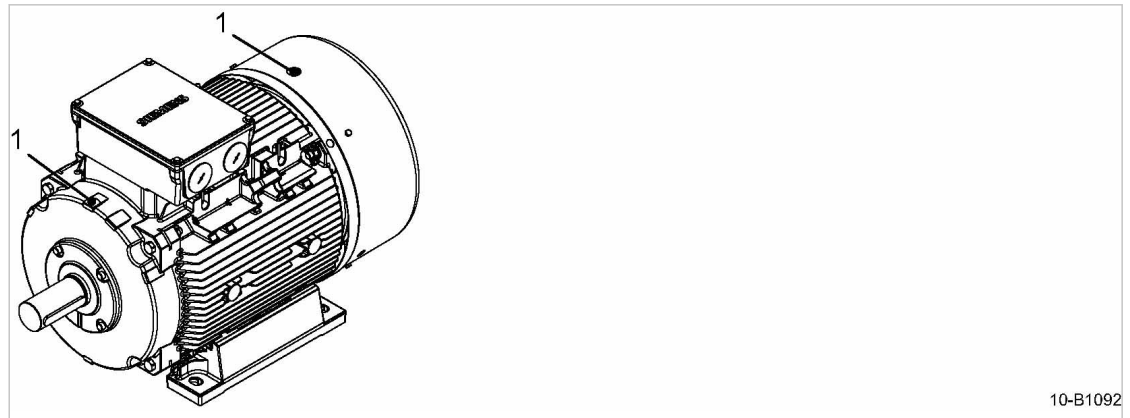

Fig. 34 Drive motor maintenance

① Grease fitting

1. Clean the fittings ① with a cloth before greasing.
2. Grease both bearings with a grease gun.

Option H12 Machine with sound enclosure

Fig. 35 Maintenance of a drive motor with re-greasing facility

① Grease fitting

1. Remove the sound enclosure access panel.
2. Clean the grease fittings ① with a cloth before greasing.
3. Grease both bearings with a grease gun.
4. Insert the access panel, close the latch.

Further information Re-greasing intervals are found in chapter 2.4 and in chapter 10.2.2.
For further information regarding the motor, please consult the motor manual.

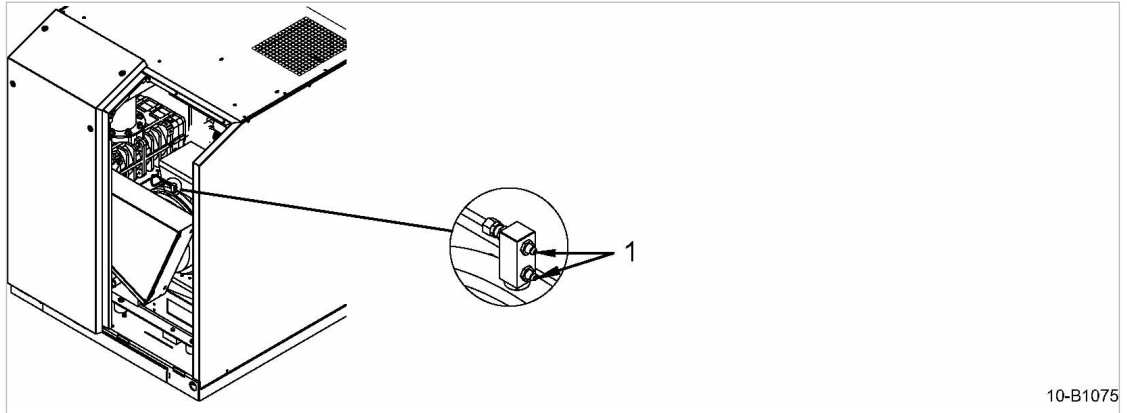
10.10.2 Permanently greased drive motor bearings

The motor bearings are permanently lubricated. Re-greasing is not necessary.

- The motor bearings must be replaced in the course of regular service calls by an authorized KAESER service representative.

Further information For further information regarding the motor, please consult the motor manual.

**10.10.3 Option H12
Sound enclosure fan motor**

The motor bearings are permanently lubricated. Re-greasing is not necessary.

- The fan must be replaced in the course of regular maintenance by an authorized KAESER service representative.

10.11 Testing the safety relief valve

Precondition The machine is switched off.
The machine is fully vented to atmosphere.

- Check the safety relief valve for free movement.
The valve opens as soon as maximum working pressure is exceeded.
- Never operate the machine without a correctly functioning safety relief valve.

- Do **not** adjust the safety relief valve.
- Replace a defective safety relief valve.

11 Spares, Operating Materials, Service

11.1 Note the nameplate

The nameplate contains all information to identify your machine. This information is essential to us in order to provide you with optimal service.

- Please give the information from the nameplate with every inquiry and order for spares.

11.2 Ordering consumable parts and operating fluids/materials

KAESER consumable parts and operating fluids/materials have the same characteristics as the originals. They are specifically selected for use in KAESER machines.

⚠ WARNING

There is risk of personal injury or damage to the machine resulting from the use of unsuitable spare parts or operating fluids/materials.

Non-Kaeser parts and operating fluids/materials may be unsuitable or of poor quality and can damage the machine or impair its proper function.

Personal injury may result from damage.

- *Use only original KAESER parts and operating fluids/materials.*
- *Have an authorized KAESER SERVICE representative carry out regular repair and maintenance.*

Machine

| Name | Number |
|-----------------|--------|
| Drive belt | 1800 |
| Air filter | 1250 |
| Lubricating oil | 1600 |

Tab. 38 Consumable parts and operating fluids/materials

11.3 Spare parts for service and repair

With the help of this parts list you can plan your material requirement according to operating conditions and order the spare parts you need.



- Make sure that any inspection, service (preventive maintenance) or repair tasks not described in this manual are carried out by an authorized KAESER service representative.

Service-Kit
(Option)

SEG-5477_01

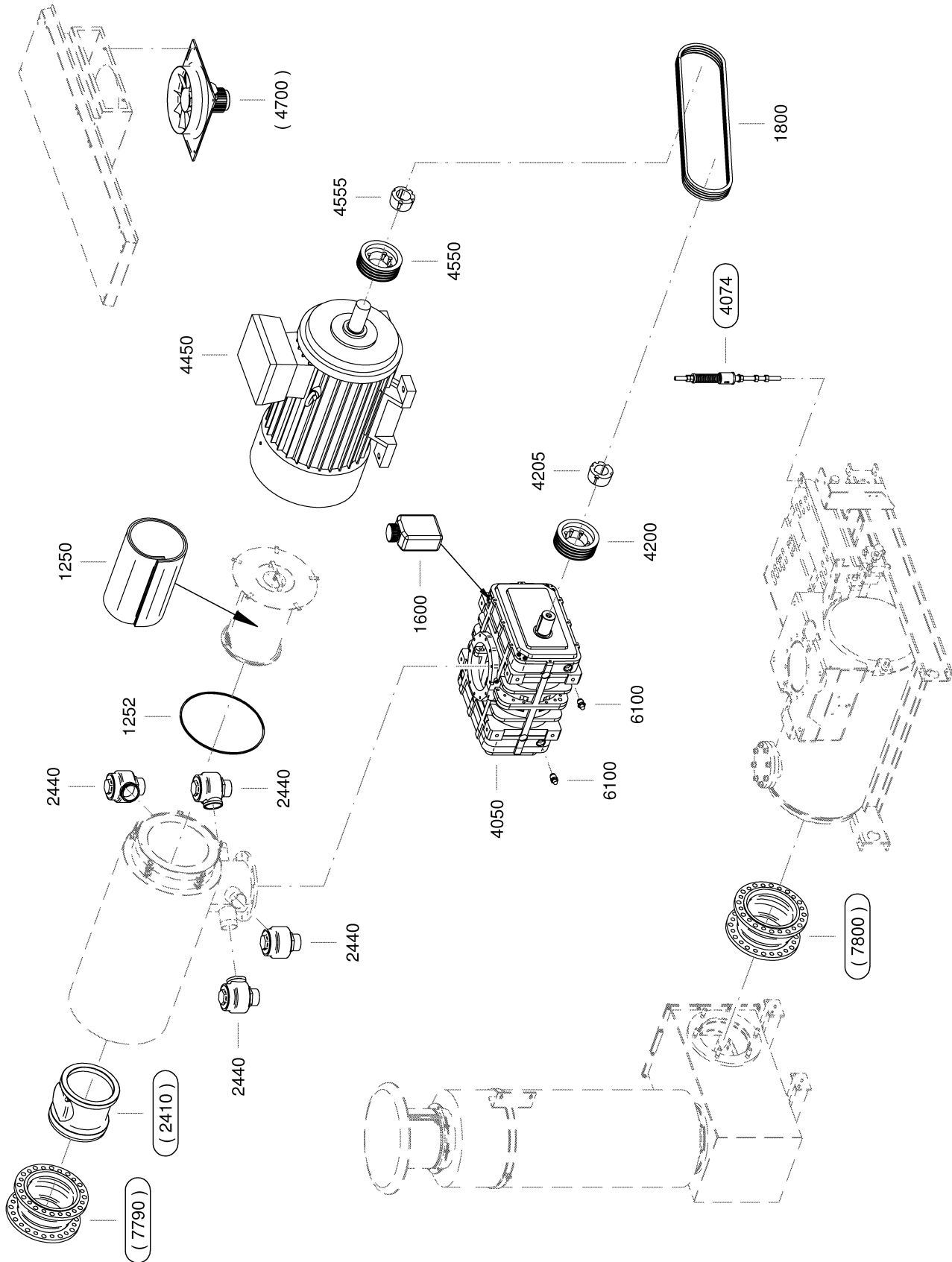

| Legend | | KAESER |
|--------------|------------------------------|---------------|
| HB 950 C vac | | SEL-3907_01 E |
| Item | Description | Option |
| 1250 | Air filter insert | |
| 1252 | Inlet silencer gasket | |
| 1600 | OMEGA FLUID | |
| 1800 | Drive belt | |
| 2410 | Check valve | X |
| 2440 | Vacuum limiting valve | |
| 4050 | OMEGA blower block | |
| 4074 | Belt tensioner | |
| 4200 | Airend pulley | |
| 4205 | Tapered bushing, airend | |
| 4450 | Drive motor | |
| 4550 | Drive motor pulley | |
| 4555 | Tapered bushing, drive motor | |
| 4700 | Fan unit | X |
| 6100 | Oil level indicator | |
| 7790 | Compensator, air inlet | X |
| 7800 | Compensator, air outlet | X |

11.4 KAESER AIR SERVICE

KAESER AIR SERVICE offers:

- authorized KAESER service representatives with KAESER factory training,
- increased operational reliability ensured by preventive maintenance,
- energy savings achieved by avoidance of pressure losses,
- optimum conditions for operation of the compressed air system,
- the security of genuine KAESER spare parts,
- increased legal certainty as all regulations are kept to.

➤ Why not sign a KAESER AIR SERVICE maintenance agreement!

Result Your advantage:
lower costs and higher compressed air availability.

11.5 Completing the contamination declaration

Every company (user) is responsible for the health and safety of its employees. This extends to personnel who carry out servicing work at the user or service contractor.

A Declaration of Contamination must be completed and signed whenever maintenance or repair work is to be carried out on the machine.

1. Contact KAESER SERVICE and request the contamination declaration form.
2. Attach a copy of the Declaration of Contamination to the **outside** of the packing.

12 Decommissioning, Storage and Transport

12.1 Decommissioning

Decommissioning is necessary under circumstances such as the following:

- The machine is (temporarily) not required.
- The machine is to be transported to another location.
- The machine is to be scrapped.

Temporary decommissioning

Precondition The machine can be started at regular intervals.

- Run the machine once per week, or once per day under unfavorable weather conditions, for a minimum of 30 minutes at operating temperature in order to ensure adequate corrosion protection.

Long-term decommissioning

Precondition The power supply disconnecting device is switched off, lock out / tag out the device, the absence of voltage has been verified.

The machine is fully vented.

1. Allow the machine to cool down completely.
2. Disconnect all connecting lines and the power supply.
3. Release the tension from the drive belt.
4. Spray the machine inside and out with a preserving agent to protect from corrosion.
5. Store the machine in a dry, frost-proof room.

Further information For information on preservative oils, see chapter 12.4.

12.2 Packing

A wooden crate is required for overland transport to protect the machine from mechanical damage. Other measures must be taken for the transport of machines by sea or air. Please contact an authorized KAESER SERVICE for more information.

Material Protective plastic sheeting
Wooden transport crate

Precondition The machine is decommissioned.
The machine is dry and cooled down.

1. Wrap the machine fully in plastic sheeting.
2. Protect the machine in a wooden crate against mechanical damages.

12.3 Transport

12.3.1 Safety

Weight and center of gravity determine the most suitable method of transportation. Both are specified in the dimensional drawing in chapter 13.2.

Precondition Transport only by pallet truck, forklift truck or lifting gear and only by personnel trained in the safe transportation of loads.

- Ensure the danger area is clear of personnel.

12.3.2 Transport machine with a pallet truck or forklift truck

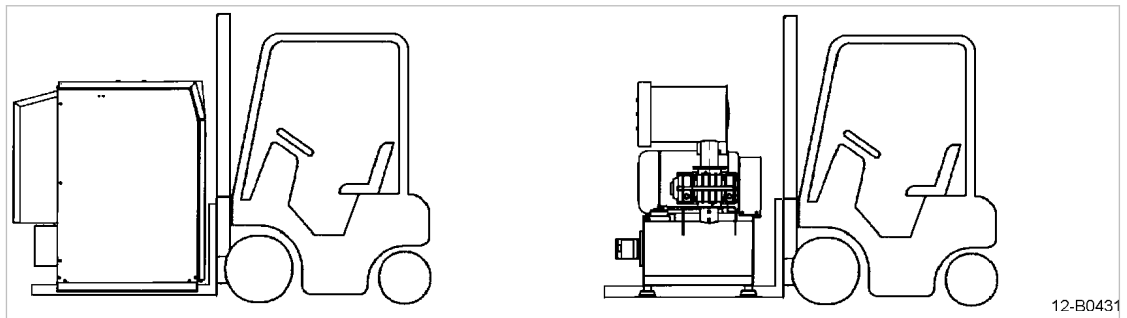

Fig. 36 Transport

1. Jack up machine if necessary.
2. Take note of the center of gravity.
3. Drive the pallet truck (or forklift truck) fully beneath the entire machine and transport with care.
4. Carry the wooden blocks with the machine to the new location.
5. Lower the machine onto the blocks.
6. Use the lever to lift the machine and remove the blocks.

12.4 Storage

Moisture can lead to corrosion, particularly on the surfaces of the blower block. The storage temperature must not fall below -86°F .



Should you have any questions concerning the correct storage and recommissioning procedure, KAESER will be glad to assist you.

⚠ CAUTION

Rotating lobes!

Danger of crushing or severing limbs.

- *Do not reach into the interior of the blower block.*
- *If full protection is only provided when the machine is completely installed, then in all other phases of the machine's life-cycle temporary protective devices (e.g. covers) must be fitted, in order to guarantee that parts of the body cannot reach or be caught/sucked in by the rotary lobes.*

NOTICE

Moisture and frost can damage the machine.

- *Prevent the ingress of moisture and formation of condensation.*
- Store the machine in a dry, frost-proof room.
- Seal off the inlet and discharge ports to prevent the ingress of dirt.
- Every month, manually turn the motor shaft by approx. 30°.
- Change the lubricating oil annually.

After long-term storage

- Observe the procedures for assembly and initial commissioning.

12.5 Disposal

When disposing of a machine, drain out all liquids and remove old filters.

Precondition The machine is decommissioned.

1. Completely drain the oil from the machine.
2. Remove old filters.
3. Hand the machine over to an authorized disposal expert.



- Components contaminated with oil must be disposed of in accordance with local environmental protection regulations.

13 Annex

13.1 Pipeline and instrument flow diagram (P+I diagram)

| | | | | | | | | |
|------|---------------------------------------|--|------------------|---|-------------------|---|---|--|
| 1 | 2 | 3 | 4 | 5 | 6 | 7 | 8 | |
| 1 | silencer | | | | | | | |
| 1.1 | blow-off silencer | | | | | | | |
| 2 | air filter | | | | | | | |
| 2.1 | differential pressure switch | | | | | | | |
| 3 | blower block | | | | | | | |
| 3.1 | drive motor | | | | | | | |
| 3.2 | PTC-sensor | | | | | | | |
| 3.3 | speed monitor | | | | | | | |
| 3.4 | oil-level sensor, switching | | | | | | | |
| 5 | pressure switch | | | | | | | |
| 6 | pressure gauge | | | | | | | |
| 7 | temperature gauge switch + indication | | | | | | | |
| 8.1 | pressure transducer - system pressure | | | | | | | |
| 10 | check plate | | | | | | | |
| 11 | compensator | | | | | | | |
| 12 | sound enclosure | | | | | | | |
| 12.1 | fan motor | | | | | | | |
| 12.2 | thermostat | | | | | | | |
| 12.3 | auxiliary heating | | | | | | | |
| 13 | inlet valve | | | | | | | |
| | option | | | | | | | |
| | C5 | oil level monitor (not on CB 111/131 C) | | | | | | |
| | C9 | high pressure warning message | | | | | | |
| | C10 | speed monitor | | | | | | |
| | C13 | temperature gauge switch | | | | | | |
| | C14 | pressure transducer | | | | | | |
| | C19 | sound enclosure thermostat | | | | | | |
| | C20 | pressure indicator | | | | | | |
| | F5 | filter pressure differential monitoring | | | | | | |
| | G1 | check plate | | | | | | |
| | H2 | auxiliary heating | | | | | | |
| | H12 | sound enclosure | | | | | | |
| | H16 | blow-off silencer | | | | | | |
| c | Datum | 18.05.2010 | | | | | | |
| b | Bearb. | Pleu | | | | | | |
| a | Gepr. | Schulz | | | | | | |
| | Änderung | Datum | Ersatz durch: | | | | | |
| | | | Ersatz für: | | | | | |
| | | | Umsprung: | | FGEC-vac-0004.01 | | | |
| | | | KOMPRESSOREN | | P&I Diagram | | | |
| | | | rotary blower | | Blatt 2 | | | |
| | | | Compact vac | | E | | | |
| | | | FGEC-vac-0004.01 | | FGEC-vac-00004.01 | | | |

13.2 Dimensional drawing

☉ : Center of gravity

| Model | Nominal power | A / A** | B / B*** | C / C*** | X* | Y* | Z* | Weight ** |
|-----------------|---------------|----------|----------|-----------|----------|---------|------------|------------|
| HB 950 C | 75 hp | 29 1/2 | 27 3/16 | | 29 1/2 | | 27 3/16 | ~ 4762 lbs |
| | 100 hp | 30 11/16 | 27 9/16 | | 30 11/16 | | 27 9/16 | ~ 5016 lbs |
| | 125 hp | 31 1/2 | 28 3/8 | | 31 1/2 | | 28 3/8 | ~ 5236 lbs |
| | 150 hp | 32 1/2 | 29 3/4 | 11 / 1/16 | 32 1/2 | 33 1/16 | 29 3/4 | ~ 5534 lbs |
| | 175 hp | 33 11/16 | 30 1/16 | | 33 11/16 | | 30 1/16 | ~ 5875 lbs |
| 200 hp | 34 7/16 | 31 1/2 | | 34 7/16 | | 31 1/2 | ~ 6184 lbs | |
| 250 hp | 35 7/16 | 31 1/2 | | 35 7/16 | | 31 1/2 | ~ 6625 lbs | |

*** Standard values, actual weight may vary according to manufacturer.
** Dimensions without check valve

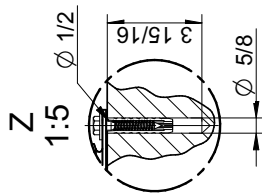

Foundation plan

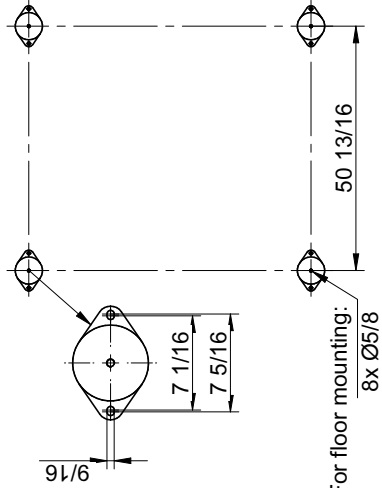

For floor mounting:
8x Ø5/8

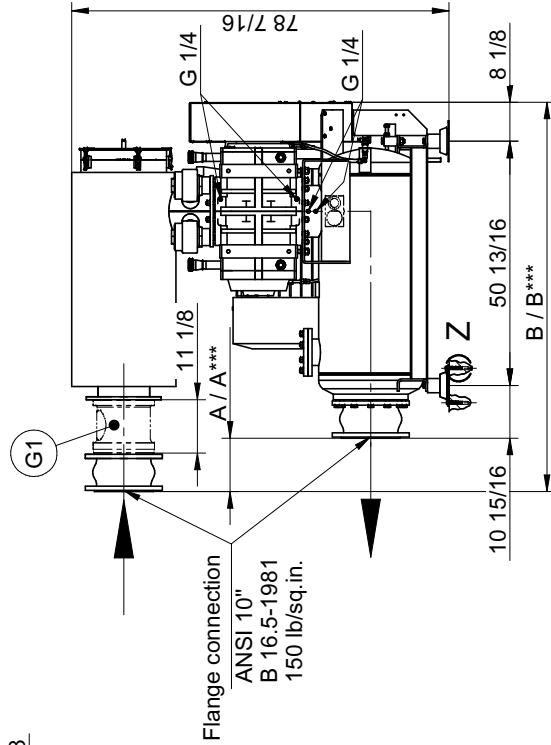
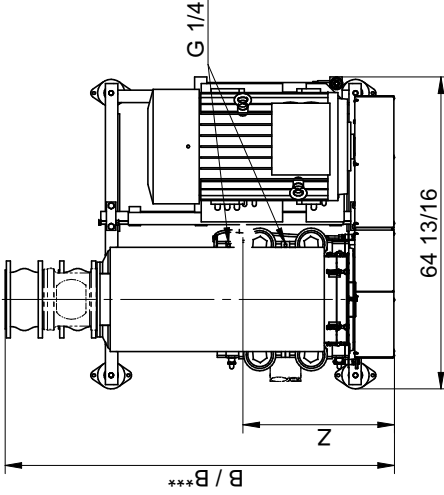

Flange connection
ANSI 10"
B 16.5-1981
150 lb/sq.in.

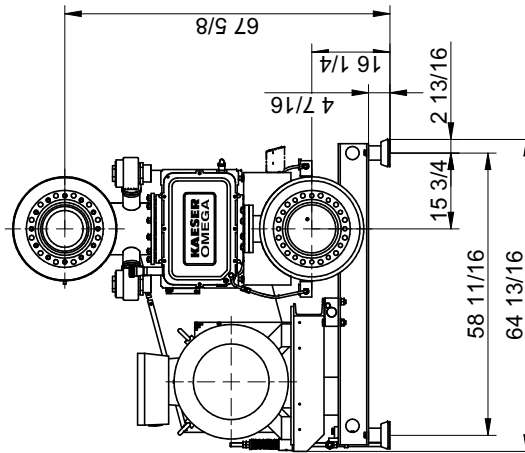

Dimensions shown in inches

| Change number | Projection | Scale | Date | Name |
|-----------------|------------|-------------------------------|------------|------------|
| 38415 | ☉ | 1:25 | 05.06.2015 | GRIEBSCH1 |
| Document TZM | | Original | 11.11.2015 | MYSIK1 |
| 10303149 USE 00 | | A3 | Released | 11.11.2015 |
| Document TZD | | Designation | HBC.1 vac | |
| 10303149 D 00 | | Dimension and connection dim. | | |
| Status | Released | | | |

G1 Check valve

| Language | Sheet |
|----------|-------|
| USE | 1 / 1 |

91.02.21.2014

Drawings remain our exclusive property. Neither originals nor reproductions may be given to or made available to third parties. Copies or any other reproductions, including storage, treatment and distribution by use of electronic systems is not allowed for any other than the agreed upon purpose. This file is intended only for the agreed upon purpose.

Center of gravity

| Model | Nominal power | A / A*** | B / B*** | X* | Y* | Z* | Weight** |
|-----------------|---------------|----------------|----------|------------|------------|----|----------|
| HB 950 C | 75 hp | 34 13/16 | 38 3/16 | 36 1/4 | ~ 6525 lbs | | |
| | 100 hp | 35 5/8 | 36 7/16 | ~ 6780 lbs | | | |
| | 125 hp | 36 1/4 | 38 | 36 13/16 | ~ 7000 lbs | | |
| | 150 hp | 13 1/4 / 2 1/8 | 37 13/16 | 36 5/8 | ~ 7300 lbs | | |
| | 175 hp | 37 13/16 | 37 5/8 | 37 5/8 | ~ 7640 lbs | | |
| 200 hp | 38 3/8 | 43 7/8 | 37 3/8 | ~ 7950 lbs | | | |
| 250 hp | 39 3/16 | 37 3/16 | 38 3/4 | ~ 8390 lbs | | | |

*(approximate dimensions)
** Standard values; actual weight may vary according to manufacturer.
*** Dimensions without check valve

For floor mounting:
4x Ø5/8

Foundation plan

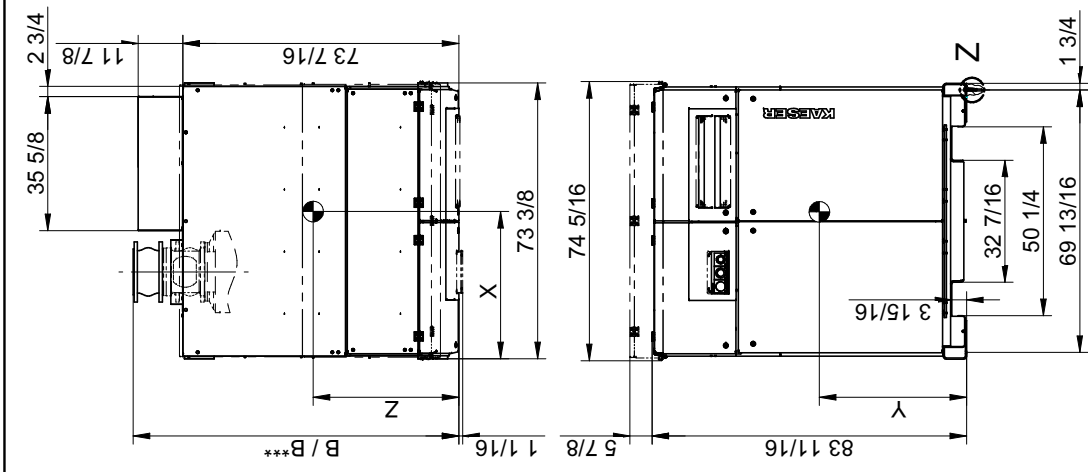
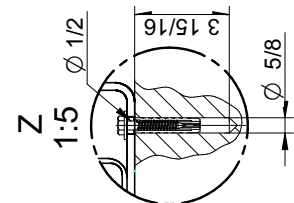
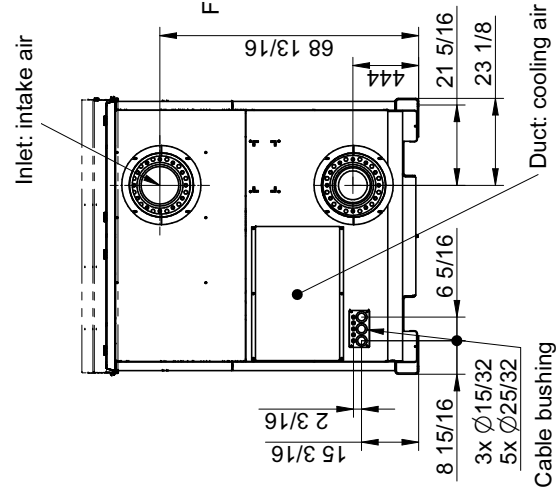
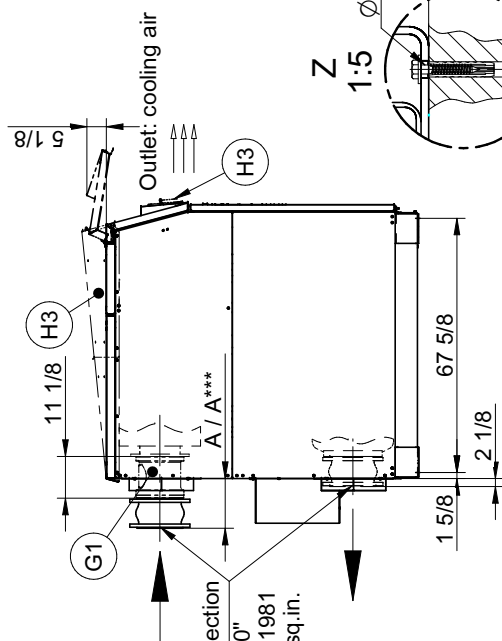
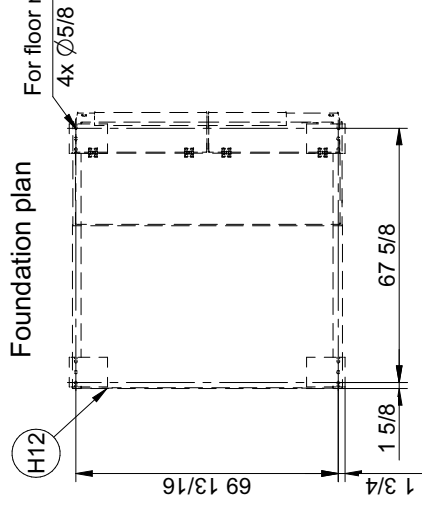

Dimensions shown in inches

| Change number | | Scale | | Projection | | Designation | |
|---------------|------|----------|--------------------------|-----------------|-----|----------------------|-------------------------------|
| 38415 | 1:32 | Original | H12 with sound enclosure | 10309198 USE 00 | H12 | with sound enclosure | HBC.1 vac H12 |
| Document TZM/ | A3 | A3 | G1 Check valve | 10309198 D 00 | G1 | Check valve | Dimension and connection dim. |
| Document TZD | | | H3 Outdoor installation | | H3 | Outdoor installation | |

| KAESER KOMPRESSOREN | |
|---------------------|------------|
| Name | GRIEBSCH1 |
| Date | 26.08.2015 |
| Drawn | MYSIK1 |
| Edited | MYSIK1 |
| Released | MYSIK1 |
| Language | USE |
| Sheet | 1 / 1 |

| Designation | |
|---------------|-------------------------------|
| HBC.1 vac H12 | Dimension and connection dim. |

| Status | |
|----------|--|
| Released | |

910221.2014

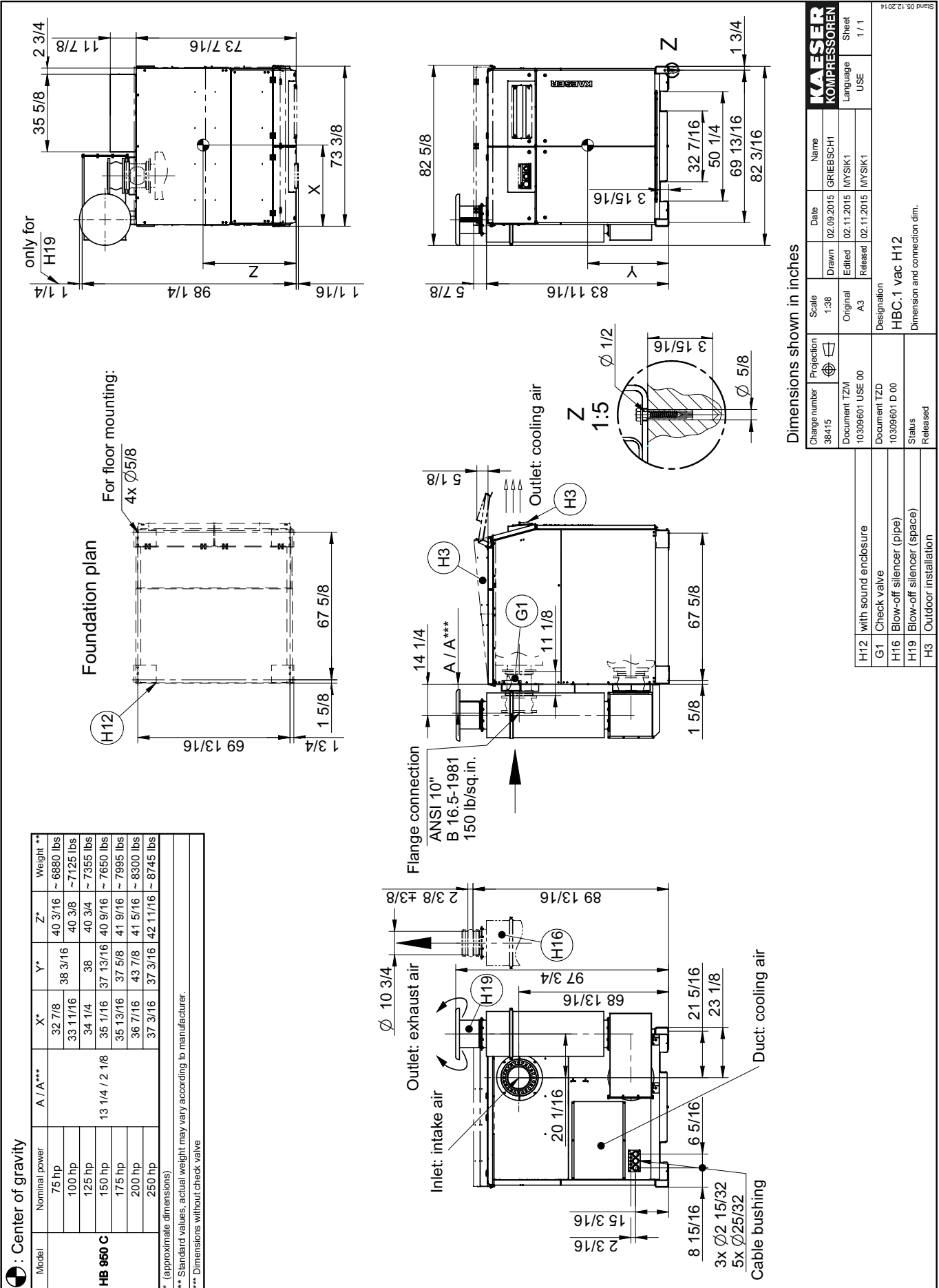

Center of gravity

| Model | Nominal power | A / A*** | X* | Y* | Z* | Weight** |
|-----------------|---------------|----------------|----------|----------|---------|------------|
| HB 950 C | 75 hp | | 32 7/8 | 38 3/16 | 40 3/16 | ~ 6880 lbs |
| | 100 hp | | 33 1/16 | 38 | 40 3/8 | ~ 7125 lbs |
| | 125 hp | 13 1/4 / 2 1/8 | 34 1/4 | 37 13/16 | 40 9/16 | ~ 7650 lbs |
| | 150 hp | | 35 1/16 | 37 5/8 | 41 9/16 | ~ 7995 lbs |
| | 175 hp | | 35 13/16 | 43 7/8 | 41 5/16 | ~ 8500 lbs |
| | 200 hp | | 36 7/16 | 37 3/16 | 42 1/16 | ~ 8745 lbs |
| | 250 hp | | 37 3/16 | | | |

* (approximate dimensions)
 ** Standard values, actual weight may vary according to manufacturer.
 *** Dimensions without check valve

Subject to development-related changes.
 Drawing may be altered only via CAD.

Drawings remain our exclusive property.
 Neither originals nor reproductions may be given to or made available to third parties.
 Copies or other reproductions, including storage, treatment and distribution by use of electronic systems is not allowed for any other than the agreed upon purpose.

13.3 Sound emission

The values for sound pressure levels and sound power levels are provided in the tables below:
Each table discusses one compressor type.

The values applicable to the machine result from the combination of the blower block speed and the differential pressure.

If the texts of the tables are not provided in the chosen language, a translation can be found here.

| | Table legend |
|----|-------------------------|
| a) | Type |
| b) | Without sound enclosure |
| c) | With sound enclosure |
| d) | Blower block speed |
| e) | Pressure differential |
| f) | Sound pressure level |
| g) | Sound power level |

Tab. 39 Sound emission - legend

| a) HB950C | | | b) without sound enclosure | | c) with sound enclosure | |
|----------------------|--------------------------|-------|----------------------------|----------------------|-------------------------|----------------------|
| d) block speed | e) pressure differential | | f) sound level | g) sound power level | f) sound level | g) sound power level |
| [min ⁻¹] | [mbar] | [psi] | [dB(A)] | [dB(A)] | [dB(A)] | [dB(A)] |
| | | | ± 3 dB(A) | ± 3 dB(A) | ± 3 dB(A) | ± 3 dB(A) |
| 1250 | 200 | 3 | 94 | 112 | 77 | 95 |
| 1250 | 300 | 4 | 94 | 112 | 77 | 96 |
| 1250 | 400 | 6 | 95 | 112 | 78 | 96 |
| 1250 | 500 | 7 | 95 | 113 | 78 | 97 |
| 1375 | 200 | 3 | 94 | 112 | 77 | 96 |
| 1375 | 300 | 4 | 95 | 112 | 78 | 96 |
| 1375 | 400 | 6 | 95 | 113 | 78 | 96 |
| 1375 | 500 | 7 | 96 | 113 | 79 | 97 |
| 1480 | 200 | 3 | 95 | 112 | 78 | 96 |
| 1480 | 300 | 4 | 95 | 112 | 78 | 96 |
| 1480 | 400 | 6 | 95 | 113 | 78 | 97 |
| 1480 | 500 | 7 | 96 | 113 | 79 | 97 |
| 1660 | 200 | 3 | 95 | 113 | 78 | 96 |
| 1660 | 300 | 4 | 95 | 113 | 78 | 96 |
| 1660 | 400 | 6 | 96 | 113 | 79 | 97 |
| 1660 | 500 | 7 | 96 | 114 | 79 | 98 |
| 1750 | 200 | 3 | 95 | 113 | 78 | 96 |
| 1750 | 300 | 4 | 95 | 113 | 78 | 97 |
| 1750 | 400 | 6 | 96 | 114 | 79 | 97 |
| 1750 | 500 | 7 | 97 | 114 | 80 | 98 |
| 1880 | 200 | 3 | 96 | 113 | 79 | 97 |
| 1880 | 300 | 4 | 96 | 113 | 79 | 97 |
| 1880 | 400 | 6 | 96 | 114 | 79 | 98 |
| 1880 | 500 | 7 | 97 | 114 | 80 | 98 |
| 1980 | 200 | 3 | 96 | 113 | 79 | 97 |
| 1980 | 300 | 4 | 96 | 113 | 79 | 97 |
| 1980 | 400 | 6 | 97 | 114 | 80 | 98 |
| 1980 | 500 | 7 | 97 | 115 | 80 | 98 |
| 2100 | 200 | 3 | 96 | 114 | 79 | 97 |
| 2100 | 300 | 4 | 96 | 114 | 79 | 97 |
| 2100 | 400 | 6 | 97 | 114 | 80 | 98 |
| 2100 | 500 | 7 | 97 | 115 | 80 | 98 |
| 2220 | 200 | 3 | 96 | 114 | 79 | 97 |
| 2220 | 300 | 4 | 96 | 114 | 79 | 98 |
| 2220 | 400 | 6 | 97 | 115 | 80 | 98 |
| 2220 | 500 | 7 | 97 | 115 | 80 | 99 |
| 2360 | 200 | 3 | 97 | 114 | 80 | 98 |
| 2360 | 300 | 4 | 97 | 114 | 80 | 98 |
| 2360 | 400 | 6 | 98 | 115 | 81 | 99 |
| 2360 | 500 | 7 | 98 | 115 | 81 | 99 |
| 2475 | 200 | 3 | 97 | 114 | 80 | 98 |
| 2475 | 300 | 4 | 97 | 114 | 80 | 98 |
| 2475 | 400 | 6 | 98 | 115 | 81 | 99 |
| 2475 | 500 | 7 | 98 | 116 | 81 | 99 |
| 2645 | 200 | 3 | 97 | 115 | 80 | 98 |
| 2645 | 300 | 4 | 97 | 115 | 80 | 98 |
| 2645 | 400 | 6 | 98 | 116 | 81 | 99 |
| 2645 | 500 | 7 | 98 | 116 | 81 | 99 |
| 2800 | 200 | 3 | 98 | 115 | 81 | 99 |
| 2800 | 300 | 4 | 98 | 115 | 81 | 99 |
| 2800 | 400 | 6 | 99 | 116 | 82 | 100 |
| 2800 | 500 | 7 | 99 | 116 | 82 | 100 |
| 2960 | 200 | 3 | 98 | 115 | 81 | 99 |
| 2960 | 300 | 4 | 98 | 115 | 81 | 99 |
| 2960 | 400 | 6 | 99 | 117 | 82 | 100 |
| 2960 | 500 | 7 | 99 | 116 | 82 | 100 |

13.4 Drive motor electrical diagram

The connection diagram is a common diagram for the main voltage and frequency.

| | | | | | | | | | | | | | | | | | | | | | | | | | | | | | | | |
|--|---|------------------|---|-------|---|---|---|----------------------------|--|------------|--|---|--|---|--|-------------|--|------------------|--|------|--|---|--|---------------|--|-------------|--|-------|--|---|--|
| 1 | 2 | 3 | 4 | 5 | 6 | 7 | 8 | | | | | | | | | | | | | | | | | | | | | | | | |
| <div style="border: 1px solid black; padding: 10px; margin: 10px;"> <p style="text-align: center;">Wiring Diagram</p> <p style="text-align: center;">drive motor</p> <p style="text-align: center;">voltage / power supply</p> <p style="text-align: center;">Wiring variants</p> <p style="text-align: center;">motor option</p> <p style="text-align: center;">Power supply:</p> <p style="text-align: center;">WYE system with center point solidly grounded</p> </div> | | | | | | | | | | | | | | | | | | | | | | | | | | | | | | | |
| <p>The document gives collective information on power supply voltages and frequencies for all machines. The voltage and frequency and local conditions under which any particular machine may be used are given on the nameplate of the machine and in the accompanying service manual.</p> | | | | | | | | | | | | | | | | | | | | | | | | | | | | | | | |
| <p>The drawings remain our exclusive property. They are entrusted only for the agreed purpose. Copies or any other reproductions, including storage, treatment and dissemination by use of electronic systems must not be made for any other than the agreed purpose. Neither originals nor reproductions must be forwarded or otherwise made accessible to third parties.</p> | | | | | | | | | | | | | | | | | | | | | | | | | | | | | | | |
| <p style="text-align: center;">manufacturer: KAESER KOMPRESSOREN SE Postfach 2143 96410 Coburg</p> | | | | | | | | | | | | | | | | | | | | | | | | | | | | | | | |
| <table border="1" style="width: 100%; border-collapse: collapse;"> <tr> <td colspan="2" style="text-align: center;">KAESER KOMPRESSOREN</td> <td colspan="2" style="text-align: center;">cover page</td> <td colspan="2" style="text-align: center;">=</td> <td colspan="2" style="text-align: center;">+</td> </tr> <tr> <td colspan="2" style="text-align: center;">drive motor</td> <td colspan="2" style="text-align: center;">DXB.SSG-03022.03</td> <td colspan="2" style="text-align: center;">page</td> <td colspan="2" style="text-align: center;">1</td> </tr> <tr> <td colspan="2" style="text-align: center;">Ersatz durch:</td> <td colspan="2" style="text-align: center;">Ersatz für:</td> <td colspan="2" style="text-align: center;">1 Bl.</td> <td colspan="2" style="text-align: center;">1</td> </tr> </table> | | | | | | | | KAESER KOMPRESSOREN | | cover page | | = | | + | | drive motor | | DXB.SSG-03022.03 | | page | | 1 | | Ersatz durch: | | Ersatz für: | | 1 Bl. | | 1 | |
| KAESER KOMPRESSOREN | | cover page | | = | | + | | | | | | | | | | | | | | | | | | | | | | | | | |
| drive motor | | DXB.SSG-03022.03 | | page | | 1 | | | | | | | | | | | | | | | | | | | | | | | | | |
| Ersatz durch: | | Ersatz für: | | 1 Bl. | | 1 | | | | | | | | | | | | | | | | | | | | | | | | | |

| Lfd. Nr. No. | Benennung Name | Zeichnungsnummer (Kunde) Drawing No. (customer) | Zeichnungsnummer (Hersteller) Drawing No. (manufacturer) | Blatt Page | Anlagenkennzeichen Unit designation |
|--------------|------------------|---|--|------------|-------------------------------------|
| 1 | cover page | | DXB.SSG-03022.03 | 1 | |
| 2 | list of contents | | ZXB.SSG-03022.03 | 1 | |
| 3 | Wiring Diagram | | SXB.SSG-03022.03 | 1 | |
| 4 | Wiring Diagram | mains voltage 6 terminals | SXB.SSG-03022.03 | 2 | |
| 5 | Wiring Diagram | mains voltage 9 terminals | SXB.SSG-03022.03 | 3 | |
| 6 | Wiring Diagram | Wiring variants 9 terminals | SXB.SSG-03022.03 | 4 | |
| 7 | Wiring Diagram | mains voltage 12 terminals | SXB.SSG-03022.03 | 5 | |
| 8 | Wiring Diagram | Wiring variants 12 terminals | SXB.SSG-03022.03 | 6 | |
| 9 | Wiring Diagram | option | SXB.SSG-03022.03 | 7 | |

| | | | | | |
|------------|------------|------------|------------------|-------------|------------------|
| c | Datum | 16.10.2018 | list of contents | = | |
| b | Bearbeiter | M.Zeeh | | + | |
| a | Geprüft | IM.Zeeh | | | |
| B Änderung | Datum | Name | Ersatz durch: | Ersatz für: | ZXB.SSG-03022.03 |
| | | | | | page 1 |
| | | | | | 1 Bl. |

1 2 3 4 5 6 7 8

drive motor 6 terminals

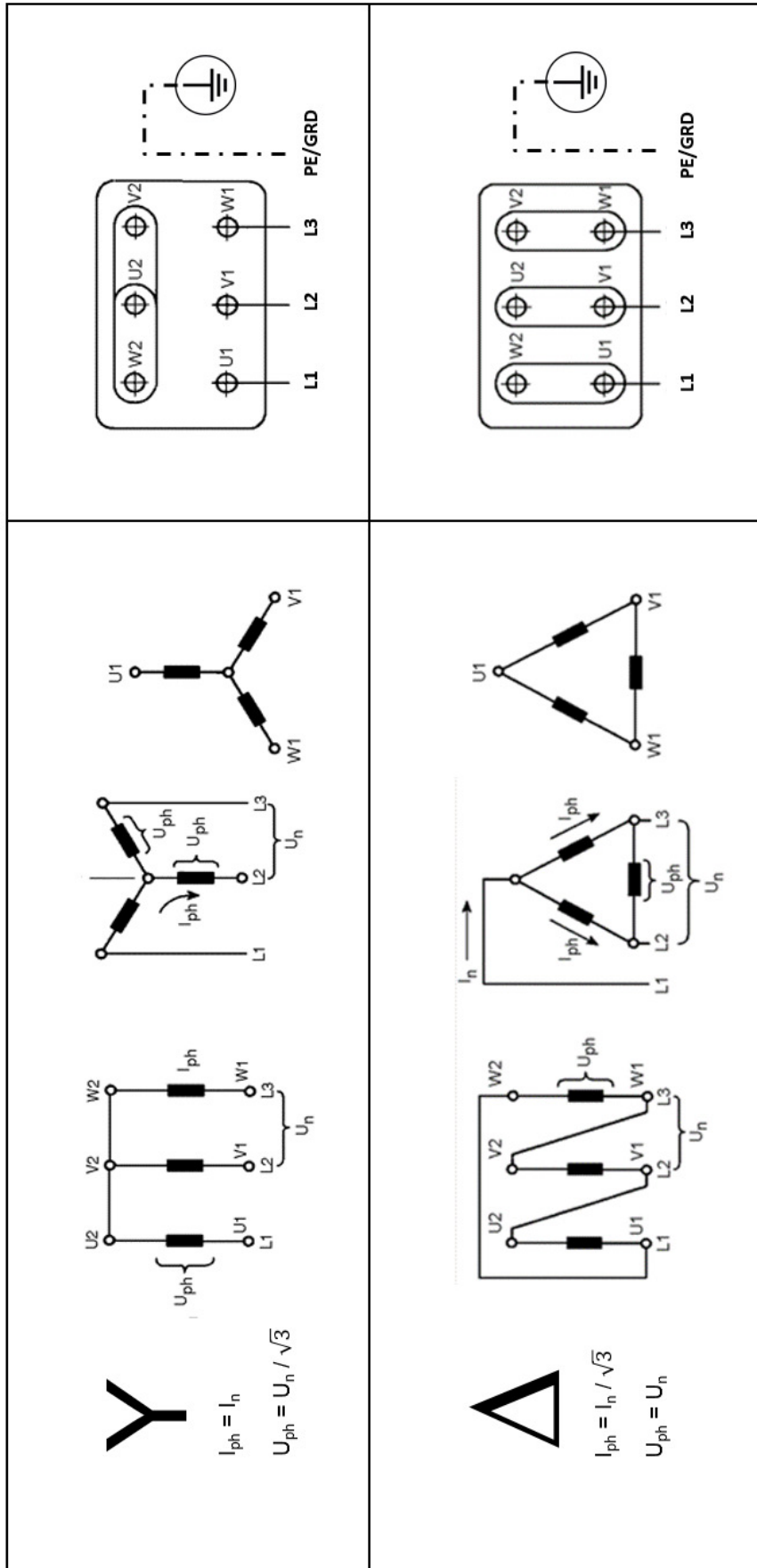

| | | | | | | |
|----------|------------|------------|------|-------------------|------|---|
| c | Datum | 16.10.2018 | = | SX.B.SSG-03022.03 | page | 2 |
| | Bearbeiter | M.Zeeh | | | | |
| b | Geprüft | M.Zeeh | + | 7 Bl. | | |
| a | Norm | | | | | |
| Änderung | | Datum | Name | Ersatz durch: | | |
| | | | | Ursprung: | | |

| | | | | | | | |
|-------------------------|---|-------------------|----------------------|-------------------|----------------------|---|---|
| 1 | 2 | 3 | 4 | 5 | 6 | 7 | 8 |
| drive motor 9 terminals | | | | | | | |
| voltage | | 50Hz power supply | | 60Hz power supply | | | |
| | | Y/D | direct on line start | Y/D | direct on line start | | |
| 208V DD - 60Hz | | | | 208V YY/DD | 208V DD | | |
| 230V DD - 60Hz | | | | 230V YY/DD | 230V DD | | |
| 400V D - 50Hz | | 400V Y/D | 400V D | | | | |
| 460V D - 60Hz | | | | 460V Y/D | 460V D | | |

| | | | | | | |
|----------|------------|------------|---------------------------|--|-------------------|--|
| c | Datum | 16.10.2018 | Wiring Diagram | | = | |
| b | Bearbeiter | M.Zeeh | drive motor 9 terminals | | + | |
| a | Geprüft | M.Zeeh | mains voltage 9 terminals | | SX.B.SSG-03022.03 | |
| Änderung | Datum | Name | Ersatz durch: | | page 3 | |
| | | | | | 7 Bl. | |

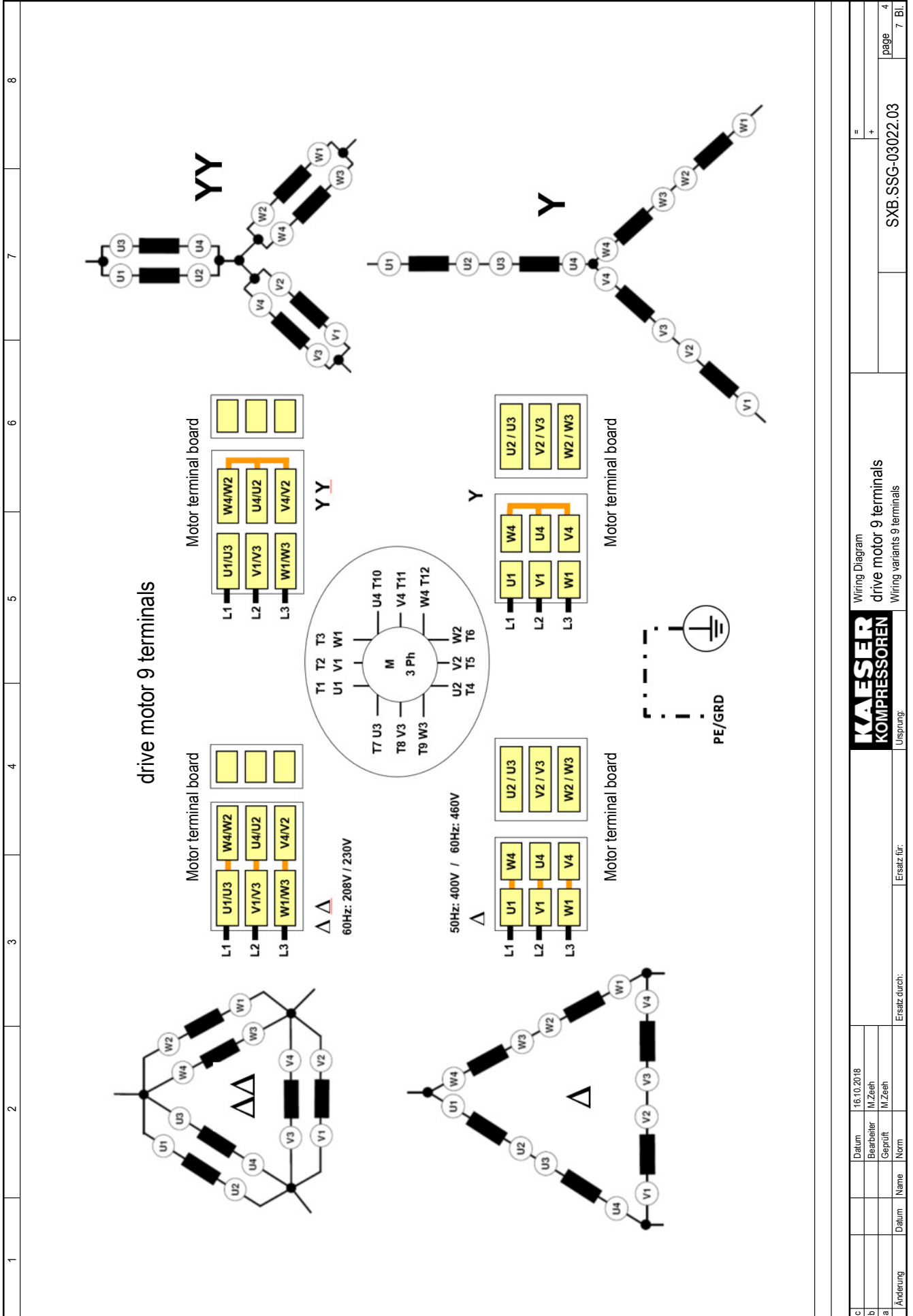

| | | | | | |
|-------------------------|--|-----------------------------|--|-------------------|--|
| Kaeser KOMPRESSOREN | | Wiring Diagram | | = | |
| drive motor 9 terminals | | drive motor 9 terminals | | + | |
| Ursprung: | | Wiring variants 9 terminals | | SX.B.SSG-03022.03 | |
| Ersatz durch: | | Ersatz durch: | | page 4 | |
| Datum | | 16.10.2018 | | 7 Bl. | |
| Bearbeiter | | M.Zeeh | | | |
| Geprüft | | M.Zeeh | | | |
| Name | | | | | |
| Datum | | | | | |
| Änderung | | | | | |

| 1 | 2 | 3 | 4 | 5 | 6 | 7 | 8 |
|--------------------------|-------------------|----------------------|----------|-------------------|----------------------|----------------------|---------|
| drive motor 12 terminals | | | | | | | |
| voltage | 50Hz power supply | | | 60Hz power supply | | | |
| | Y/D | direct on line start | Y/D | Y/D | direct on line start | direct on line start | |
| 200V DD - 50Hz | 200V YY/DD | 200V DD | | | | | |
| 200V DD - 60Hz | | | 380V Y/D | 200V YY/DD | 200V YY/DD | 200V DD | 200V DD |
| 208V DD - 60Hz | | | 400V Y/D | | 208V YY/DD | 208V DD | 208V DD |
| 220V DD - 60Hz | | | 420V Y/D | | 220V YY/DD | 220V DD | 220V DD |
| 230V DD - 60Hz | | | | | 230V YY/DD | 230V DD | 230V DD |
| 380V D - 50Hz | | | | | | | |
| 400V D - 50Hz | | | 380V D | | | | |
| 420V D - 50Hz | | | 400V D | | | | |
| 420V D - 60Hz | | | 420V D | | | | |
| 440V D - 60Hz | | | | | 420V Y/D | 420V D | 420V D |
| 460V D - 60Hz | | | | | 440V Y/D | 440V D | 440V D |
| 480V D - 60Hz | | | | | 460V Y/D | 460V D | 460V D |
| | | | | | 480V Y/D | 480V D | 480V D |

| | | | | | | | |
|---|------------|--------|-------------|---|---|---|--------|
| c | Datum | | Ersatz für: | Ersatz durch: | = | + | page 5 |
| | Bearbeiter | M.Zeeh | | | | | |
| b | Geprüft | M.Zeeh | | | | | 7 Bl. |
| a | Name | | | | | | |
| <p style="text-align: center;">KAESER KOMPRESSOREN Ursprung:</p> | | | | <p style="text-align: center;">Wiring Diagram drive motor 12 terminals mains voltage 12 terminals</p> | | | |
| | | | | SXB.SSG-03022.03 | | | |

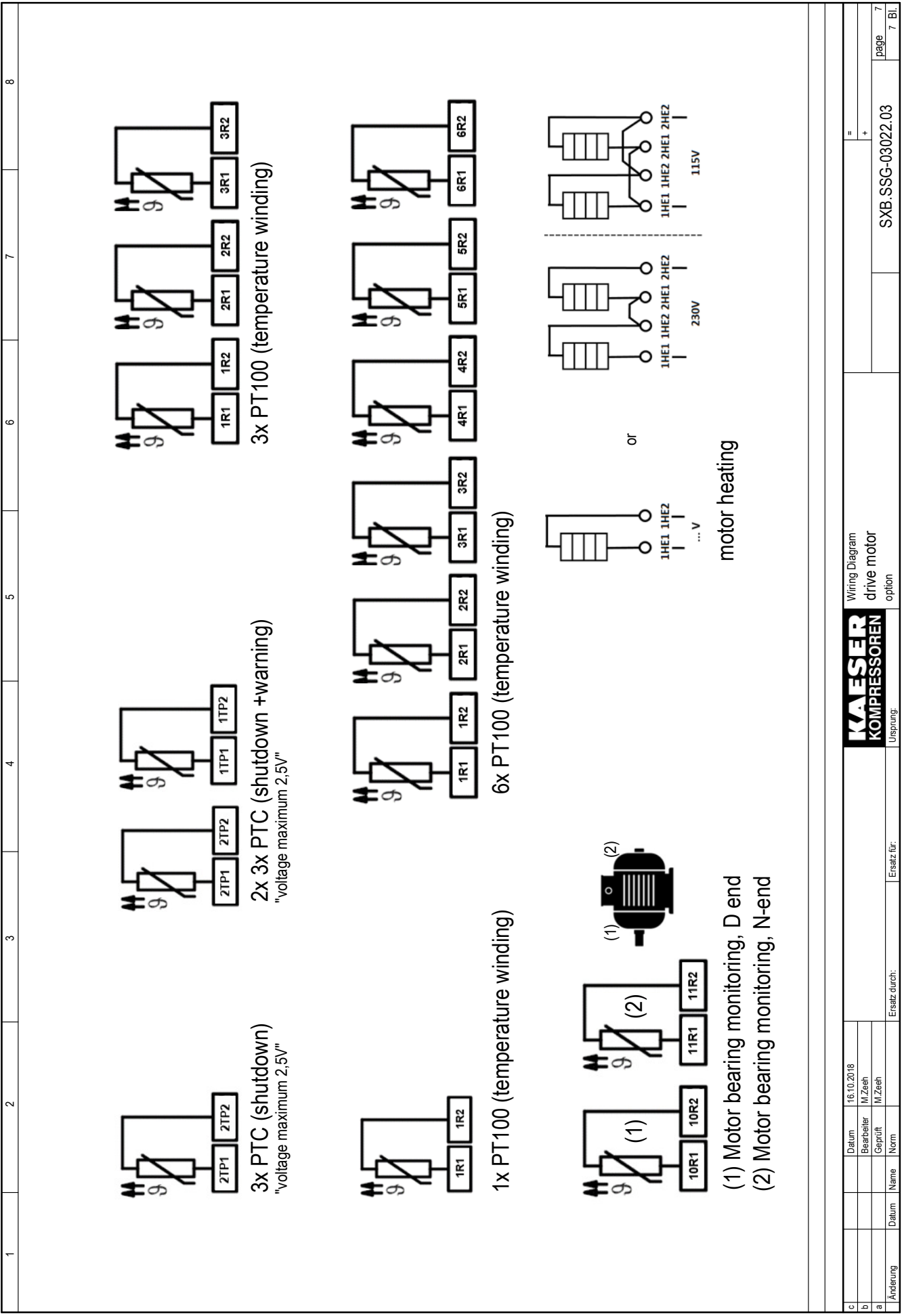

13.5 Electrical diagrams for options

Electrical diagrams for the options available for your machine are given in the following.

13.5.1 Option C5 Oil level monitoring – wiring diagram

| | | | | | | | | |
|--|------------|------------|------|------|---------------|-------------|--|---|
| 1 | 2 | 3 | 4 | 5 | 6 | 7 | 8 | |
| <p>Schaltungsunterlagen Electrical diagrams Gebläse/Blower Ölstandswächter/Oil level monitoring TT/TN-Netz mit geerdetem Sternpunkt TT/TN power supply with common point grounding</p> | | | | | | | | |
| <p>Dieses Dokument beinhaltet einen Sammelplan für alle hier aufgeführten Anlagentypen, Netzspannungen und Frequenzen. Unter welchen tatsächlichen Spannungen, Frequenzen und Umgebungsbedingungen die jeweilige Anlage ausschließlich betrieben werden darf, ist dem Typenschild der Anlage sowie der beiliegenden Betriebsanleitung zu entnehmen.</p> | | | | | | | | |
| <p>The document gives collective information on power supply voltages and frequencies for all machines. The voltage and frequency and local conditions under which any particular machine may be used are given on the nameplate of the machine and in the accompanying service manual.</p> | | | | | | | | |
| <p>Die Schaltungsunterlagen bleiben unser ausschließliches Eigentum. Sie werden nur zu dem vereinbarten Zweck anvertraut. Kopien oder sonstige Vervielfältigungen einschließlich der Speicherung, Verarbeitung und Verbreitung unter Verwendung elektronischer Systeme dürfen nur zu dem vereinbarten Zweck angefertigt werden. Weder Originale noch Vervielfältigungen dürfen Dritten ausgehändigt oder in sonstiger Weise zugänglich gemacht werden.</p> | | | | | | | | |
| <p>The drawings remain our exclusive property. They are entrusted only for the agreed purpose. Copies or any other reproductions, including storage, treatment and dissemination by use of electronic systems must not be made for any other than the agreed purpose. Neither originals nor reproductions must be forwarded or otherwise made accessible to third parties.</p> | | | | | | | | |
| c | Datum | 17.01.2012 | D | | | | | = |
| b | Bearbeiter | M. Zeeh | | | | | | + |
| a | Geprüft | M. Zeeh | | | | | | |
| A | Änderung | Datum | Name | Norm | Ersatz durch: | Ersatz für: | Ursprung: | |
| | | | | | | | Deckblatt Ölstandswächter Oil level monitoring | |
| | | | | | | | SXB.DSG-03011.00 | |
| | | | | | | | Blatt 1 1 Bl. | |

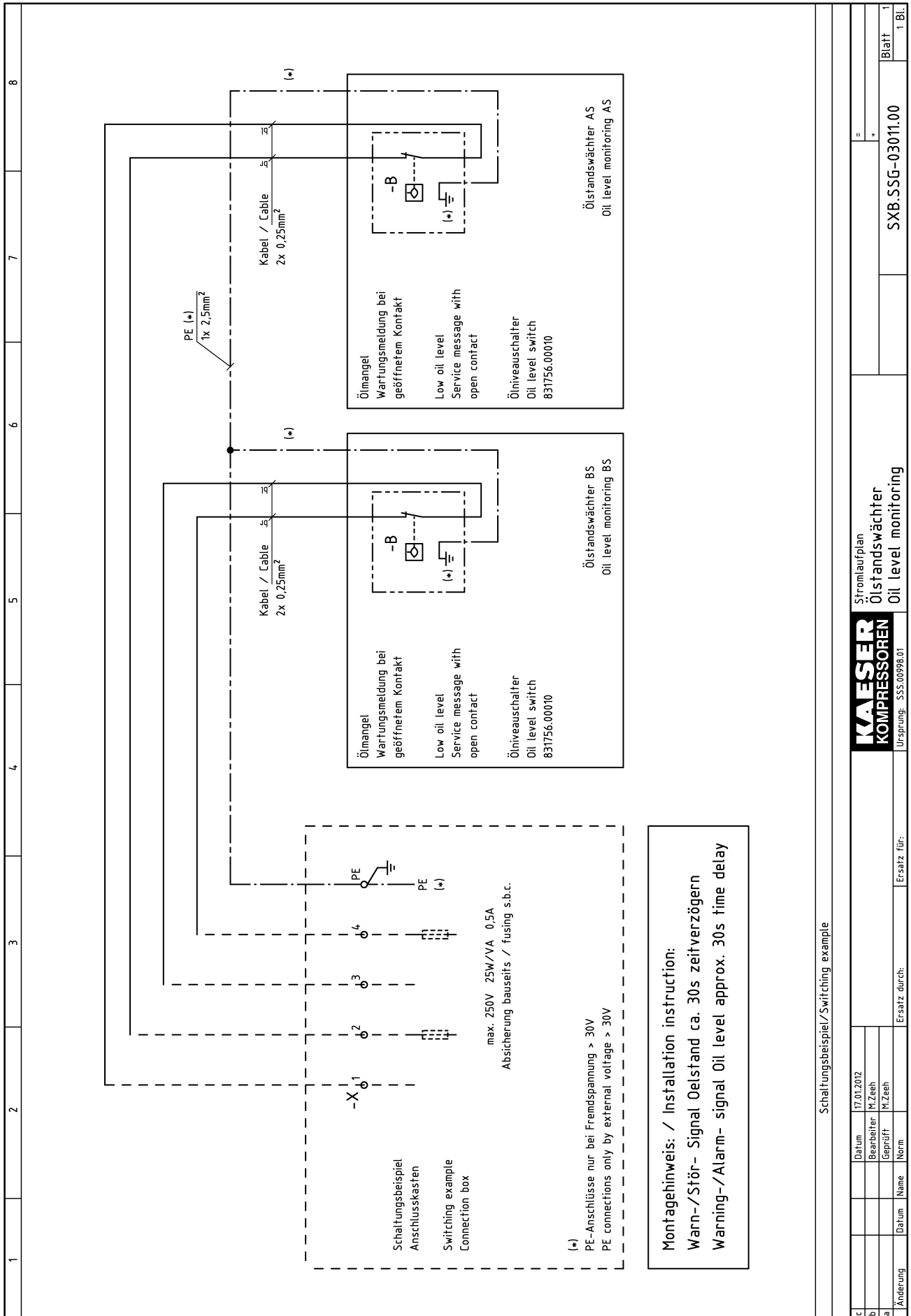

13.5.2 Option C9
Pressure switch wiring diagram

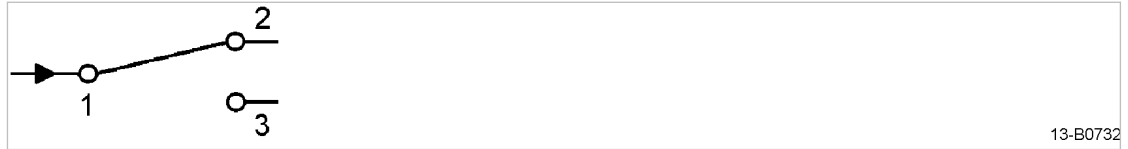

13-B0732

Fig. 37 Pressure switch wiring diagram

- ① Supply
- ② Break contact
- ③ Make contact

13.5.3 Option C10
Speed monitor wiring diagram

Sensor / evaluation device



13-B0810

Fig. 38 Speed monitor wiring diagram

13.5.4 Option C13
Temperature gauge switch wiring diagram

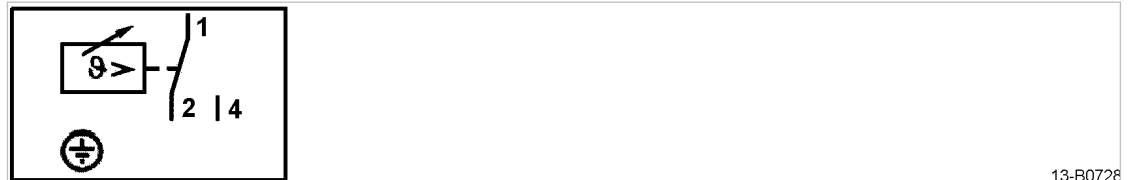

13-B0728

Fig. 39 Temperature gauge switch wiring diagram

13.5.5 Option C14
Pressure sensor connections

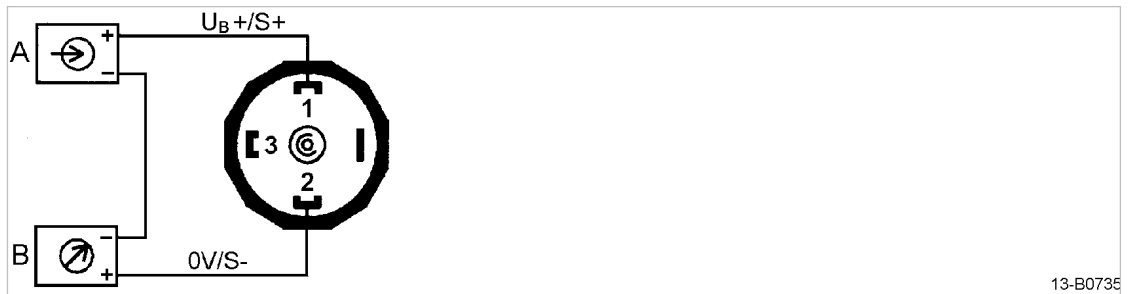

13-B0735

Fig. 40 Pressure sensor connections

- (A) Power supply
- (B) Evaluation/display

13.5.6 Option C19 Thermostat wiring diagram

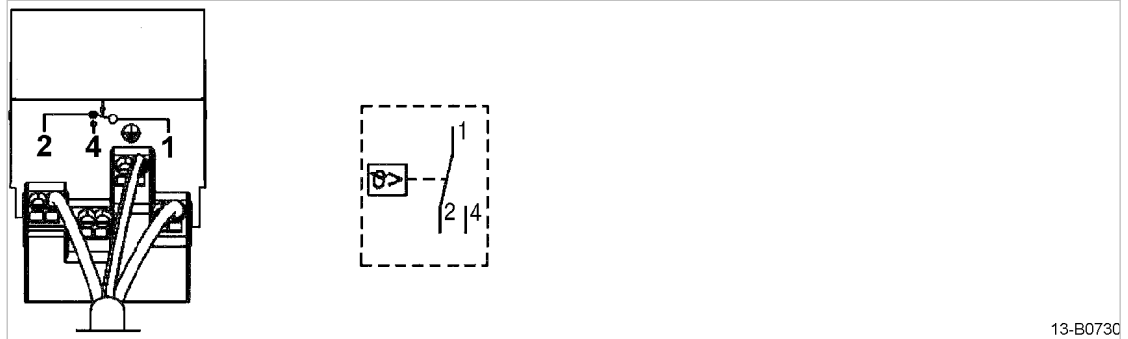

13-B0730

Fig. 41 Thermostat wiring diagram

13.5.7 Option F5 Filter pressure differential switch wiring diagram

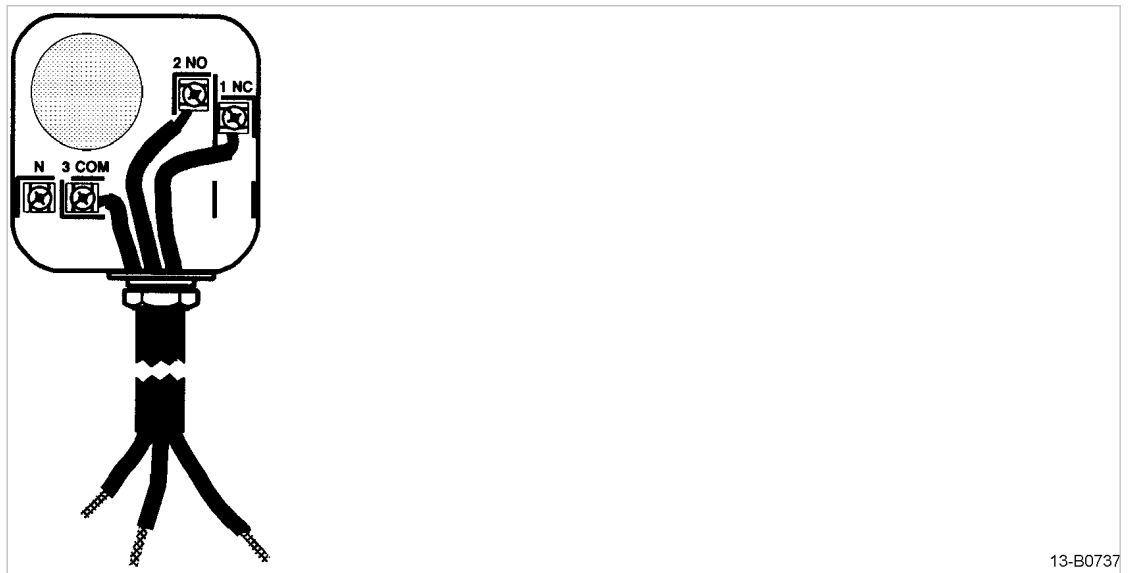

13-B0737

Fig. 42 Filter pressure differential switch wiring diagram

13.5.8 Option H2 Auxiliary heater wiring diagram

| | | | | | | | | |
|---|------------|------------|------|----------------|---------------|------------------|---------|---|
| 1 | 2 | 3 | 4 | 5 | 6 | 7 | 8 | |
| <p style="text-align: center;">Schaltungsunterlagen Electrical diagrams</p> <p style="text-align: center;">Gebläse/Blower</p> <p style="text-align: center;">Heizung/Heater – 115...127V 50/60Hz</p> <p style="text-align: center;">TT/TN-Netz mit geerdetem Sternpunkt TT/TN power supply with common point grounding</p> | | | | | | | | |
| <p style="text-align: center;">Hersteller: KAESER KOMPRESSOREN GmbH Postfach 2143 96410 Coburg</p> | | | | | | | | |
| <p>Dieses Dokument beinhaltet einen Sammelplan für alle hier aufgeführten Anlagentypen, Netzspannungen und Frequenzen. Unter welchen tatsächlichen Spannungen, Frequenzen und Umgebungsbedingungen die jeweilige Anlage ausschließlich betrieben werden darf, ist dem Typenschild der Anlage sowie der beiliegenden Betriebsanleitung zu entnehmen.</p> <p>The document gives collective information on power supply voltages and frequencies for all machines. The voltage and frequency and local conditions under which any particular machine may be used are given on the nameplate of the machine and in the accompanying service manual.</p> <p>Die Schaltungsunterlagen bleiben unser ausschließliches Eigentum. Sie werden nur zu dem vereinbarten Zweck anvertraut. Kopien oder sonstige Vervielfältigungen einschließlich der Speicherung, Verarbeitung und Verbreitung unter Verwendung elektronischer Systeme dürfen nur zu dem vereinbarten Zweck angefertigt werden. Weder Originale noch Vervielfältigungen dürfen Dritten ausgehändigt oder in sonstiger Weise zugänglich gemacht werden.</p> <p>The drawings remain our exclusive property. They are entrusted only for the agreed purpose. Copies or any other reproductions, including storage, treatment and dissemination by use of electronic systems must not be made for any other than the agreed purpose. Neither originals nor reproductions must be forwarded or otherwise made accessible to third parties.</p> | | | | | | | | |
| c | Datum | 17.01.2012 | D | Deckblatt | | | | = |
| b | Bearbeiter | M. Zeeh | | Heizung/Heater | | | | + |
| a | Geprüft | M. Zeeh | | | | | | |
| A | Änderung | Datum | Name | Norm | Ersatz durch: | Ersatz für: | Blatt 1 | |
| | | | | | | | 1 Bl. | |
| | | | | | | SXB.DSG-03015.00 | | |

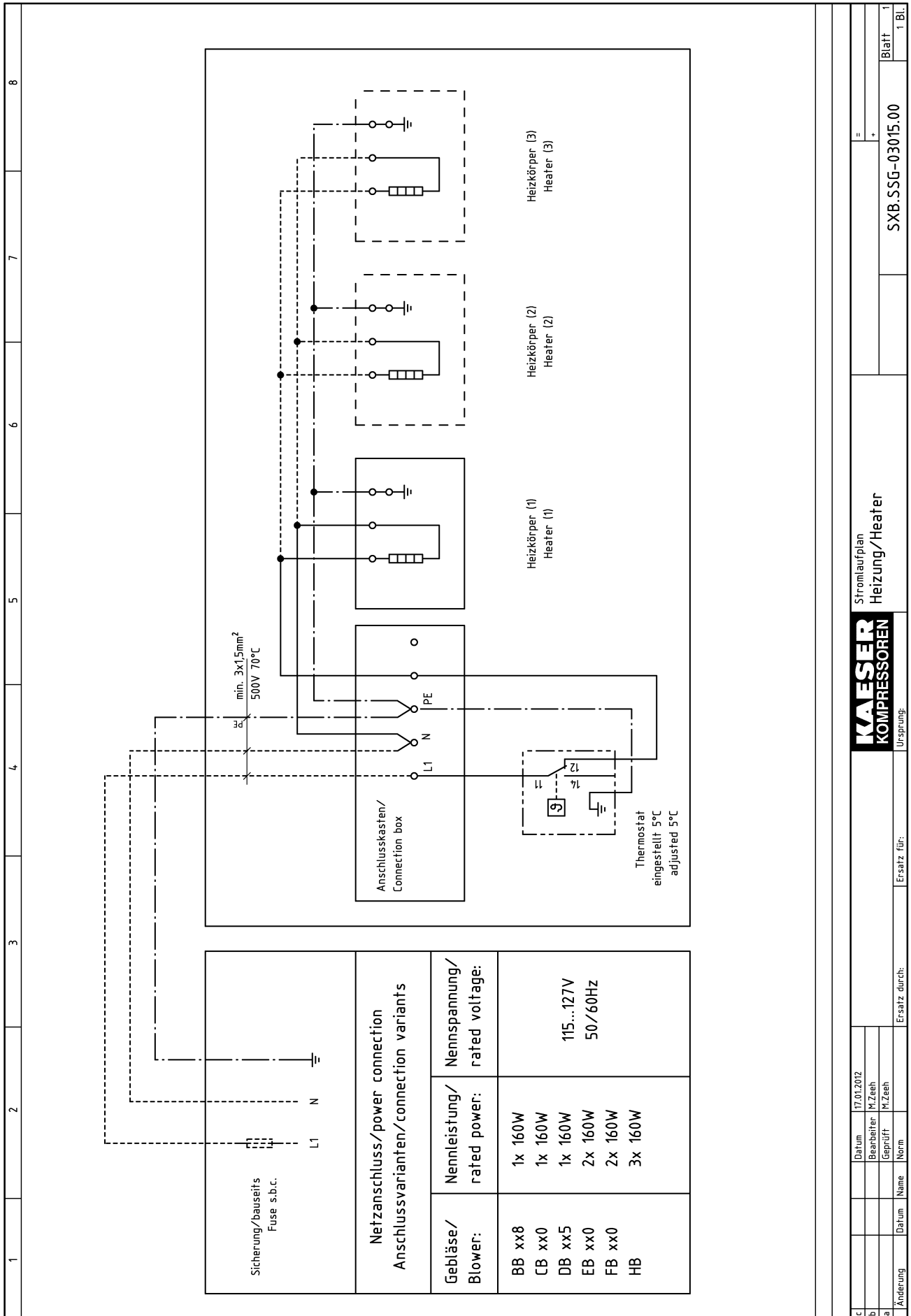

| | | | | | | | | |
|---|------------|------------|------|----------------|---------------|-------------|------------------|---|
| 1 | 2 | 3 | 4 | 5 | 6 | 7 | 8 | |
| <p style="text-align: center;">Schaltungsunterlagen Electrical diagrams</p> <p style="text-align: center;">Gebläse/Blower</p> <p style="text-align: center;">Heizung/Heater – 208...230V 50/60Hz</p> <p style="text-align: center;">TT/TN-Netz mit geerdetem Sternpunkt TT/TN power supply with common point grounding</p> | | | | | | | | |
| <p style="text-align: center;">Hersteller: KAESER KOMPRESSOREN GmbH Postfach 2143 96410 Coburg</p> | | | | | | | | |
| <p>Dieses Dokument beinhaltet einen Sammelplan für alle hier aufgeführten Anlagentypen, Netzspannungen und Frequenzen. Unter welchen tatsächlichen Spannungen, Frequenzen und Umgebungsbedingungen die jeweilige Anlage ausschließlich betrieben werden darf, ist dem Typenschild der Anlage sowie der beiliegenden Betriebsanleitung zu entnehmen.</p> <p>The document gives collective information on power supply voltages and frequencies for all machines. The voltage and frequency and local conditions under which any particular machine may be used are given on the nameplate of the machine and in the accompanying service manual.</p> <p>Die Schaltungsunterlagen bleiben unser ausschließliches Eigentum. Sie werden nur zu dem vereinbarten Zweck anvertraut. Kopien oder sonstige Vervielfältigungen einschließlich der Speicherung, Verarbeitung und Verbreitung unter Verwendung elektronischer Systeme dürfen nur zu dem vereinbarten Zweck angefertigt werden. Weder Originale noch Vervielfältigungen dürfen Dritten ausgehändigt oder in sonstiger Weise zugänglich gemacht werden.</p> <p>The drawings remain our exclusive property. They are entrusted only for the agreed purpose. Copies or any other reproductions, including storage, treatment and dissemination by use of electronic systems must not be made for any other than the agreed purpose. Neither originals nor reproductions must be forwarded or otherwise made accessible to third parties.</p> | | | | | | | | |
| c | Datum | 17.01.2012 | D | Deckblatt | | | | = |
| b | Bearbeiter | M. Zeeh | | Heizung/Heater | | | | + |
| a | Geprüft | M. Zeeh | | | | | | |
| A | Änderung | Datum | Name | Norm | Ersatz durch: | Ersatz für: | SXB.DSG-03014.00 | |
| | | | | | | | Blatt 1 | |
| | | | | | | | 1 Bl. | |

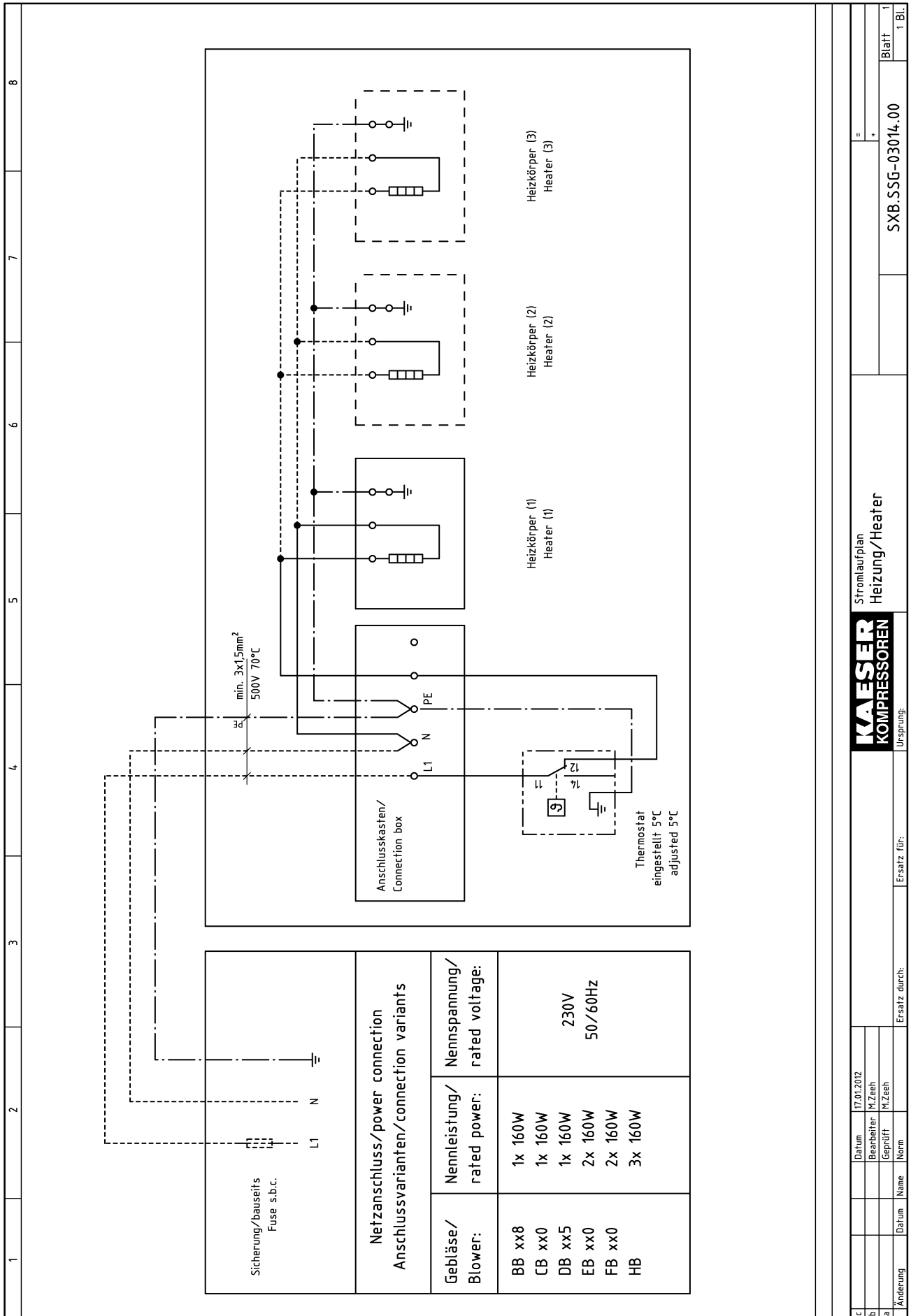

1 2 3 4 5 6 7 8

| | | | | | |
|----------|------------|------------|----------------|-------------|------------------|
| c | Datum | 17.01.2012 | Stromlaufplan | | = |
| b | Bearbeiter | M. Zeeh | Heizung/Heater | | + |
| a | Geprüft | M. Zeeh | KOMPRESSOREN | | |
| Änderung | Datum | Norm | Ersatz durch: | Ersatz für: | |
| | | | | | SXB.SSG-03014.00 |
| | | | | | Blatt 1 |
| | | | | | 1 Bl. |

13.5.9 Option H12

Sound enclosure fan motor wiring diagram

13.5.9.1 Power supply

Three-phase motor connection

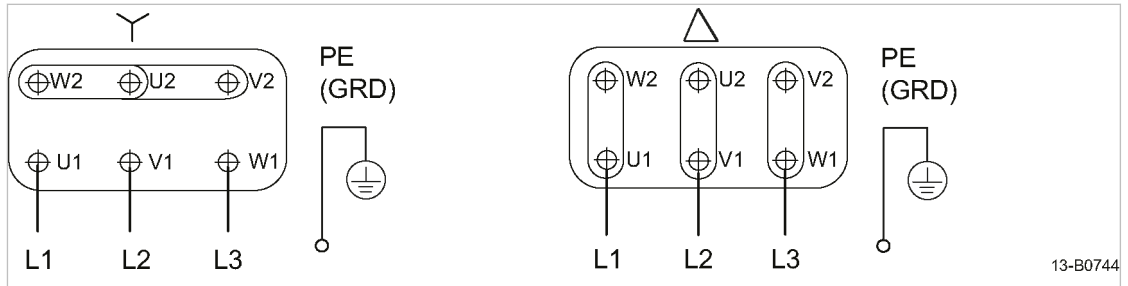

Fig. 43 Three-phase motor connection

Single-phase motor connection

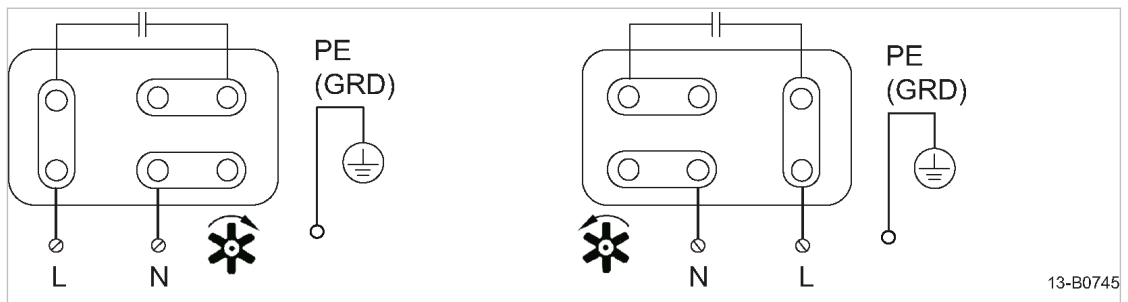

Fig. 44 Single-phase motor connection

13.6 Project planning data