

# SERVICE MANUAL

**Refrigeration Dryer**

**Model TCH**

No.: 9\_5756\_02USE



<b>1</b>	<b>Regarding this Document</b>	<b>1 – 1</b>
1.1	Handling the Document	1 – 1
1.2	Copyright	1 – 1
1.3	Symbols and Identification	1 – 1
1.3.1	Warning notices	1 – 1
1.3.2	Other notices and symbols	1 – 1
<b>2</b>	<b>Technical Specification</b>	<b>2 – 2</b>
2.1	Weight	2 – 2
2.2	Ambient Conditions	2 – 2
2.3	Compressed Air System	2 – 3
2.4	Refrigerant System	2 – 3
2.5	Sound pressure level	2 – 3
2.6	Electrical Connection	2 – 3
2.6.1	Power supply	2 – 3
2.6.2	Power supply specifications	2 – 4
<b>3</b>	<b>Safety and Responsibility</b>	<b>3 – 5</b>
3.1	Specified Use	3 – 5
3.2	Unspecified Use	3 – 5
3.3	User's Responsibilities	3 – 5
3.3.1	Qualified personnel	3 – 5
3.4	Safety Devices	3 – 6
3.5	Dangers	3 – 6
3.5.1	Awareness of danger sources	3 – 6
3.5.2	Safe machine operation	3 – 8
3.5.3	Organisational measures	3 – 9
3.6	Warning Symbols on the machine	3 – 9
3.7	In Emergency	3 – 10
3.7.1	Contact with refrigerant	3 – 10
3.8	Environmental Protection	3 – 10
3.9	Warranty	3 – 10
<b>4</b>	<b>Design and Function</b>	<b>4 – 11</b>
4.1	Machine Overview	4 – 11
4.1.1	Cabinet	4 – 11
4.2	General Design	4 – 12
4.3	Function	4 – 12
4.4	Safety Devices	4 – 13
4.5	Pressure Dew Point Indicator	4 – 13
4.5.1	Recognising the operational state	4 – 13
4.6	Accessories	4 – 14
4.6.1	Bypass line (see chapter 6.5)	4 – 14

<b>5</b>	<b>Installation and Operating Conditions</b>	<b>5 – 15</b>
5.1	Surroundings	5 – 15
5.2	Installation Conditions	5 – 15
5.2.1	Place of installation and space required	5 – 15
5.2.2	Operating in a compressed air system	5 – 16
<b>6</b>	<b>Installation</b>	<b>6 – 17</b>
6.1	Safety	6 – 17
6.2	Reporting Transport Damage	6 – 17
6.3	Remove Transport Securing Device	6 – 17
6.4	Compressed Air Connection	6 – 18
6.4.1	Shut-off valves:	6 – 18
6.5	Bypass line (accessory)	6 – 18
6.5.1	Bypassing the refrigeration dryer (when required)	6 – 18
6.6	Condensate Drain Line Connection	6 – 19
6.7	Electrical Connection	6 – 19
<b>7</b>	<b>Initial Start-up</b>	<b>7 – 20</b>
7.1	Safety	7 – 20
7.2	To be Observed Before Every Initial Start-up	7 – 20
7.3	Checking Installation and Operating Conditions	7 – 20
7.4	Starting the Machine for the First Time	7 – 21
<b>8</b>	<b>Operation</b>	<b>8 – 22</b>
8.1	Switching On and Off	8 – 22
8.1.1	Switching on	8 – 22
8.1.2	Starting the machine after a fault	8 – 22
8.1.3	Switching off	8 – 22
<b>9</b>	<b>Fault Finding and Removal</b>	<b>9 – 23</b>
9.1	Faults	9 – 23
<b>10</b>	<b>Maintenance</b>	<b>10 – 24</b>
10.1	Safety	10 – 24
10.2	Regular maintenance work	10 – 24
10.2.1	General checks.	10 – 24
10.2.2	Cleaning the refrigerant condenser	10 – 25
10.2.3	Checking condensate drainage	10 – 26
10.2.4	Cleaning the condensate drain	10 – 27
10.3	Logging Maintenance Work	10 – 28

<b>11 Spares, Operating Materials, Service .....</b>	<b>11 – 29</b>
11.1 Note the nameplate .....	11 – 29
11.2 Ordering Consumable Parts and Operating Materials .....	11 – 29
11.3 Maintenance Agreement .....	11 – 29
11.4 Service Addresses .....	11 – 29
11.5 Spare Parts for Service and Repair .....	11 – 29
<b>12 Decommissioning, Storage and Transport .....</b>	<b>12 – 34</b>
12.1 Decommissioning .....	12 – 34
12.2 Packaging .....	12 – 34
12.3 Storage .....	12 – 34
12.4 Transportation .....	12 – 35
12.5 Disposal .....	12 – 35
<b>13 Annex .....</b>	<b>13 – 36</b>
13.1 Diagrams and Drawings .....	13 – 36
13.1.1 Pipeline and instrument flow diagram (P&I diagrams) .....	13 – 36
13.1.2 Dimensional Drawing .....	13 – 39
13.1.3 Electrical diagram .....	13 – 41

Fig. 1	Warning symbols on the machine .....	3 – 9
Fig. 2	Cabinet .....	4 – 11
Fig. 3	Machine overview .....	4 – 12
Fig. 4	Pressure dew point indicator .....	4 – 13
Fig. 5	Installation recommendation, dimensions [in] .....	5 – 15
Fig. 6	Remove Transport Securing Device .....	6 – 17
Fig. 7	Operation without bypass line .....	6 – 18
Fig. 8	Operating with bypass line .....	6 – 19
Fig. 9	Switching on and off .....	8 – 22
Fig. 10	RESET .....	8 – 22
Fig. 11	Cleaning the refrigerant condenser and condensate drain .....	10 – 25
Fig. 12	Testing the condensate drain .....	10 – 26
Fig. 13	Cleaning the condensate drain .....	10 – 27
Fig. 14	Transport using a fork lift truck .....	12 – 35

Tab. 1	Nameplate .....	2 – 2
Tab. 2	Machine weight .....	2 – 2
Tab. 3	Ambient Conditions .....	2 – 2
Tab. 4	Compressed air system .....	2 – 3
Tab. 5	Refrigerant system .....	2 – 3
Tab. 6	Sound pressure level .....	2 – 3
Tab. 7	Power supply details 230V/1/60Hz .....	2 – 4
Tab. 8	Power supply details 115V/1/60Hz .....	2 – 4
Tab. 9	Indication .....	4 – 13
Tab. 10	Installation conditions checklist .....	7 – 20
Tab. 11	Faults and Remedies .....	9 – 23
Tab. 12	Maintenance log .....	10 – 28

## 1 Regarding this Document

### 1.1 Handling the Document

The service manual is part of the machine.

- ☞ Keep the service manual in a safe place throughout the life of the machine.
- ☞ Pass the manual on to the next owner/user of the machine.
- ☞ Ensure that all amendments received are entered in the manual.
- ☞ Enter details from the machine nameplate and individual equipment in the table in chapter 2 "Technical Specifications".

### 1.2 Copyright

This service manual is copyright protected. Please contact KAESER if you have any queries regarding use and copying of the documentation. We will gladly help you in using the information appropriately.

### 1.3 Symbols and Identification

#### 1.3.1 Warning notices



**DANGER**

Here is a notice that warns you of danger.

Here are consequences of ignoring the warning notice.  
The word 'DANGER' means that death or severe injury can result if the warning notice is ignored.

- ☞ Always read and comply with warning notices.

#### Danger levels

Warning notices indicate three levels of danger signified by the word below the danger symbol.

Signal word	Meaning	Consequences of non-compliance
DANGER	Warns of imminent threatening danger	Death or severe injury or serious damage to the machine is possible
WARNING	Warns of a possible threat of danger	Death or severe injury or serious damage to the machine is possible
CAUTION	Warns of a possibly dangerous situation	Light injury or damage to property possible

#### 1.3.2 Other notices and symbols



This symbol indicates that a task is to be carried out.



This symbol identifies environmental protection measures.



This symbol refers to important information.



## 2 Technical Specification

Model designation and important technical information is found on the machine's nameplate. The nameplate is located on the outside of the machine.

Please enter the data from the nameplate here.

Model	
Material no.	
Year of manufacture	
Serial no.	
Refrigerant	
Refrigerant charge	
Maximum working pressure (refrigerant system)	
Maximum working pressure (air system)	
Checked for leaks	
Rated voltage	
Rated current	
Ambient temperature	

Tab. 1 Nameplate

### 2.1 Weight

The weight given is the maximum. Actual weights of individual machines are dependent on equipment fitted.

	<b>TCH 22</b>	<b>TCH 26</b>	<b>TCH 32</b>	<b>TCH 35</b>
Weight [lb]	120	125	130	140

Tab. 2 Machine weight

### 2.2 Ambient Conditions

	<b>TCH 22</b>	<b>TCH 26</b>	<b>TCH 32</b>	<b>TCH 35</b>
Maximum elevation above sea level* [ft.]	3000	3000	3000	3000
Ambient temperature [° F]	40 – 110	40 – 110	40 – 110	40 – 110
Inlet air / cooling air temperature [° F]	40 – 110	40 – 110	40 – 110	40 – 110

\* Higher elevation permissible only after consultation with the manufacturer

Tab. 3 Ambient Conditions

## 2.3 Compressed Air System

	TCH 22	TCH 26	TCH 32	TCH 35
Pressure drop* [psi]	3.1	3.6	4.4	4.4
Flow rate* [cfm]	78	92	110	124
Maximum permitted working pressure [psig]	230	230	230	230
Pressure dew point [° F]	38	38	38	38

\* at 100° F air inlet, 100psig, 100° F ambient temperature and 60 Hz power supply

Tab. 4 Compressed air system

## 2.4 Refrigerant System

	TCH 22	TCH 26	TCH 32	TCH 35
Refrigerant	R 134a	R 134a	R 134a	R 134a
Maximum charge [lb]	1.5	1.5	1.5	1.7
Maximum permitted working pressure [psig]	260	260	300	300
Safety pressure switch Cut-out pressure [psig]	260	260	300	300

Tab. 5 Refrigerant system

## 2.5 Sound pressure level

Operational state:

- Nominal air flow and nominal pressure

Measurement conditions:

- free-field measurement to CAGI/PNEUROP PN8 NTC 2.3 at 1 m distance

	TCH 22	TCH 26	TCH 32	TCH 35
Sound pressure level [dB(A)]*	< 70	< 70	< 70	< 70

Tab. 6 Sound pressure level

## 2.6 Electrical Connection

See electrical diagrams in chapter 13.1.3 for further information.

### 2.6.1 Power supply

The machine is designed for an electrical supply according to National Electric Code (NEC) NEC-670, particularly NFPA 79, section 5.7. In the absence of any user-specified alternatives, the limits given in these standards must be adhered to. Consult manufacturer for any other specific power supply.

**2.6.2 Power supply specifications**

The following multi-strand copper core wires are given according to 2002 NEC 310-15, Table 310-16 for 40 °C ambient temperature.

If other local conditions prevail, like for example high temperature, the cross section should be checked and adjusted according to 2002 NEC 110-14©, 220-3, 310-15, Table 310-16, 430-6, 430-22, 430-24 and other local codes.

Dual element time delay fuses are selected according to 2002 NEC 240-6, 430-52 and tables 430-52, 430-148 and 430-150.

We strongly suggest using a separate copper conductor for the equipment GROUNDING. NEC Table 250.122 will point out the "minimum size", however, we recommend a ground conductor the same size as the power leads, if local codes allow.

**Rated power supply 230V ±10%. 1-ph. 60Hz**

	<b>TCH 22</b>	<b>TCH 26</b>	<b>TCH 32</b>	<b>TCH 35</b>
Mains fuses [A]	6	6	10	10
Supply cable	AWG 14	AWG 14	AWG 14	AWG 14
Current drawn [A]	4.35	4.6	6.0	7.2

*Tab. 7 Power supply details 230V/1/60Hz*

**Rated power supply 115V ±10%. 1-ph. 60Hz**

	<b>TCH 22</b>	<b>TCH 26</b>	<b>TCH 32</b>	<b>TCH 35</b>
Mains fuses [A]	15	15	20	20
Supply cable	AWG 14	AWG 14	AWG 14	AWG 14
Current drawn [A]	9.8	9.6	12.2	12.5

*Tab. 8 Power supply details 115V/1/60Hz*

### 3 Safety and Responsibility



**Disregard of these instructions can result in serious injury.**

**DANGER**

☞ Read the service manual carefully and pay attention to its contents.

The machine is manufactured to the latest engineering standards and acknowledged safety regulations. Nevertheless, dangers can arise through its operation:

- Danger to life and limb of the operator or third parties
  - Impairments to the machine and other material assets.
- ☞ Use this machine only if it is in a technically perfect condition and only for the purpose for which it is intended, observing all safety measures and the instructions in the service manual.
- ☞ In particular, immediately rectify (have rectified) any faults that could be detrimental to safety.

#### 3.1 Specified Use

The machine is intended solely to dry compressed air for industrial use. Any other use is considered incorrect. The manufacturer is not liable for any damages resulting from unspecified use or application. The risk involved in such unspecified use is taken solely by the user.

Specified use also includes compliance with the instructions in this manual.

#### 3.2 Unspecified Use

The compressed air generated:

- ☞ may not be directed at persons or animals,
- ☞ must not contain toxic, acidic, flammable or explosive gases or vapours,
- ☞ may not be used for breathing purposes without suitable treatment,
- ☞ may not be used without appropriate treatment for any application that will bring it into direct contact with foodstuffs.

#### 3.3 User's Responsibilities

**Observe statutory and accepted regulations.**

Observe relevant statutory regulations during installation, operation and maintenance of the machine. For example: nationally applied directives and/or valid national legislation, safety and accident prevention regulations.

##### 3.3.1 Qualified personnel

Ensure that operating, installation and maintenance personnel are qualified and authorized to carry out their tasks.

These are people who, by virtue of their training, knowledge and experience as well as their knowledge of relevant regulations can assess the work to be done and recognize the possible dangers involved.

**Operating personnel**

Authorized operating personnel:

- must be adult,
- must be conversant with and adhere to the safety instructions and sections of the service manual relevant to operation of the machine,
- must have received adequate training and authorization to operate electrical, compressed air and refrigeration devices.

**Installation and maintenance personnel**

Authorised installation and maintenance personnel:

- must be adult,
- must have read, be conversant with and adhere to the safety instructions and sections of the service manual applicable to installation and maintenance,
- must be fully conversant with the safety concepts and regulations of electrical, compressed air engineering and refrigeration techniques,
- must be able to recognize the possible dangers of electrical, compressed air and refrigeration techniques and take appropriate measures to safeguard persons and property,
- must have received adequate training and authorization for the safe installation and maintenance on these machines.

**3.4 Safety Devices**

Do not change, bypass or disable safety devices.

Do not remove or obliterate labels and notices.

Ensure that labels and notices are clearly legible.

More information on safety devices is contained in chapter 4 'Design and Function', section 4.4 'Safety Devices'.

**3.5 Dangers**

The general safety instructions in this chapter indicate the possible dangers and how to deal with them.

Special safety instructions are found in this service manual at the beginning of each chapter or directly before handling instructions.

**3.5.1 Awareness of danger sources**

Here are to be found the various forms of danger that can arise in connection with machine operation.

**Electricity**

- ☞ Allow only qualified electricians or trained personnel under the supervision of a qualified electrician to work on electrical equipment according to electrical engineering regulations.
- ☞ Before initial start-up, make sure that adequate protection against electric shock from direct or indirect contact with the machine is installed and checked.
- ☞ Isolate all phases of the main power supply.
- ☞ Check that there is no voltage present.
- ☞ Switch off any external power sources.  
These can be, for example, power supplied through a volt-free (dry) contact or electrical machine heating.
- ☞ Use fuses corresponding to the machine power.
- ☞ Regularly check that all electrical connections are tight.

**Pressure forces**

Compressed air is a contained force. Uncontrolled release of this energy can cause serious injury or death.

Before all work on a pressure system:

- ☞ close shut-off valves or otherwise isolate the machine from the air network to ensure that no compressed air can flow back into the machine,
- ☞ Do not carry out welding, heat treatment or mechanical modifications to pressure components (e.g. pipes and vessels) as this influences the component's pressure resistance.  
The safety of the machine is then no longer ensured.

**Compressed air quality**

- ☞ Use appropriate systems for air treatment before using the compressed air from this machine as breathing air and/or for the processing of food.
- ☞ Never directly inhale compressed air.
- ☞ Use food-compatible cooling oil whenever compressed air is to come into contact with food.

**Rotating components**

Touching the fan while the machine is switched on can result in serious injury.

- ☞ Make sure all covers and safety guards are in place and secured before switching on.

**Temperature**

- ☞ Avoid contact with hot components.
- ☞ Wear protective clothing.
- ☞ If welding is carried out on or near the machine take adequate measures to ensure that no parts of the machine or any oil vapours can ignite because of sparks or heat.

**Operating materials**

- ☞ Strictly forbid fire, open flame and smoking.
- ☞ Follow safety regulations when dealing with refrigerants and chemical substances.
- ☞ Allow only qualified specialists to work on refrigerant circuits.
- ☞ Avoid contact with skin and eyes.
- ☞ Keep suitable fire extinguishing agents ready to use.
- ☞ Use only KAESER approved operating materials.

**Unsuitable spare parts**

- ☞ Use only spare parts approved by the manufacturer for use in this machine. Unsuitable spare parts compromise the safety of the machine.
- ☞ Use only genuine KAESER parts for pressure components.

**Conversion or modification of the machine**

- ☞ Do not permit conversion or modification of the machine as this can compromise function and safe working.

### 3.5.2 Safe machine operation

Here is found information to support safe conduct with the machine.

#### Transport

- ☞ Use suitable lifting gear that conforms to local safety regulations.
- ☞ Attach lifting gear only to the designated points on the machine.
- ☞ Note the centre of gravity to avoid the machine tipping.
- ☞ Make sure the danger zone is clear.

#### Installation

- ☞ Make sure no power is applied when electrical connections are made.
- ☞ Only use only electrical cables that are suitable and approved for the electrical loads applied.
- ☞ Install or remove pressure lines only when they are in the depressurized condition.
- ☞ Only use pressure lines that are suitable and approved for the maximum working pressure and medium used.
- ☞ Do not step onto machine components to climb up the machine.

#### Location

- ☞ Install the machine in a suitable room.  
If installed outdoors, the machine must be protected from frost, direct sunlight, dust and rain.
- ☞ The machine is not explosion-proof.  
Do not operate in areas in which specific requirements with regard to explosion prevention are applied.
- ☞ Ensure adequate ventilation.
- ☞ Observe the required ambient conditions:
  - ambient temperature and humidity,
  - clean inlet air with no damaging contaminants,
  - inlet air free of explosive or chemically unstable gases or vapors,
  - inlet air free of acid/alkaline forming substances, particularly ammonia, chlorine or hydrogen sulphide.
- ☞ Do not position the machine in the warm exhaust air from other machines.
- ☞ Ensure accessibility so that all work on the machine can be carried out without danger or hindrance.

#### Operation

- ☞ Keep the machine enclosure closed for safety and correct cooling function.
- ☞ Carry out regular inspections:
  - for damage,
  - of the safety devices,

#### Maintenance

- ☞ Make sure the machine is disconnected from electrical power and vented before commencing any maintenance work.
- ☞ Wear close-fitting, flame-resistant clothing. Wear protective clothing as necessary.
- ☞ Do not leave any loose components, tools or cleaning rags on or in the machine.

**Decommissioning / disposal**

- ☞ Do not damage the refrigerant circuit.
- ☞ Give refrigerant only to authorized bodies for disposal.
- ☞ Dispose of the machine in accordance with local environmental regulations.

**3.5.3 Organisational measures**

- ☞ Designate personnel and their responsibilities.
- ☞ Give clear instructions on reporting faults and damage to the machine.
- ☞ Give instructions on fire reporting and fire-fighting measures.

**3.6 Warning Symbols on the machine**

	<p><b>Electric Shock can result from components connected to an electrical power source.</b></p> <p>Contact with energized components can cause serious injury or death.</p> <ul style="list-style-type: none"><li>☞ Switch off control switch and lock out / tag out.</li><li>☞ Check that no voltage is present.</li></ul>
-----------------------------------------------------------------------------------	------------------------------------------------------------------------------------------------------------------------------------------------------------------------------------------------------------------------------------------------------------------------------------------------------------------------------

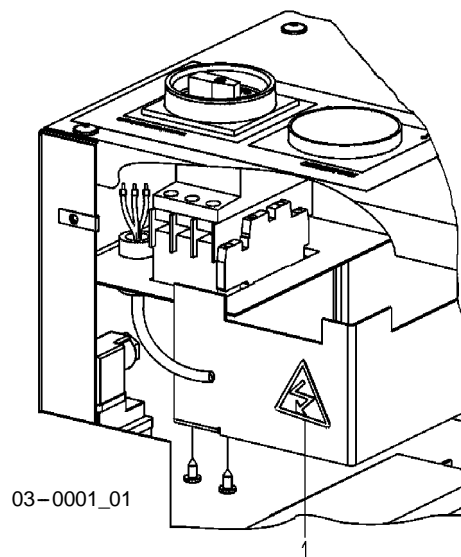

Fig. 1 Warning symbols on the machine

1 Warning symbol



### 3.7 In Emergency

#### 3.7.1 Contact with refrigerant

**Inhalation:**

- ☞ Remove the affected person to fresh air and make him or her rest.  
If breathing stops, apply artificial respiration and call for medical assistance.

**Skin contact:**

- ☞ Rinse immediately with plenty of water.  
Treat burns and frostbite.

**Eye contact:**

- ☞ Rinse thoroughly with lukewarm water and seek medical assistance.

If required, request a copy of the safety data sheet dealing with the handling of refrigerants for KAESER dryers.

### 3.8 Environmental Protection



Do not allow refrigerant to escape to the atmosphere.

Give refrigerant only to authorized bodies for disposal.



Do not allow refrigerant compressor oil to escape to the environment or into the sewage system.

Store and dispose of operating materials and replaced parts in accordance with local environmental protection regulations. Observe national regulations. This applies particularly to parts contaminated by oil.

### 3.9 Warranty

This service manual contains no independent warranty commitment.  
Our general terms and conditions of business apply with regard to warranty.

A condition of our warranty is that the machine is used for the purpose for which it is intended under the conditions specified.

Due to the multitude applications for which the machine is suitable the obligation lies with the user to determine its suitability for his specific application.

- ☞ Obtain confirmation from the manufacturer that the machine is suitable for your specific application.

Furthermore, we accept no warranty obligation for:

- the use of unsuitable parts or operating materials,
- unauthorized modifications,
- incorrect maintenance,
- incorrect repair.

Correct maintenance and repair includes the use of genuine KAESER spare parts and operating materials.

## 4 Design and Function

### 4.1 Machine Overview

#### 4.1.1 Cabinet

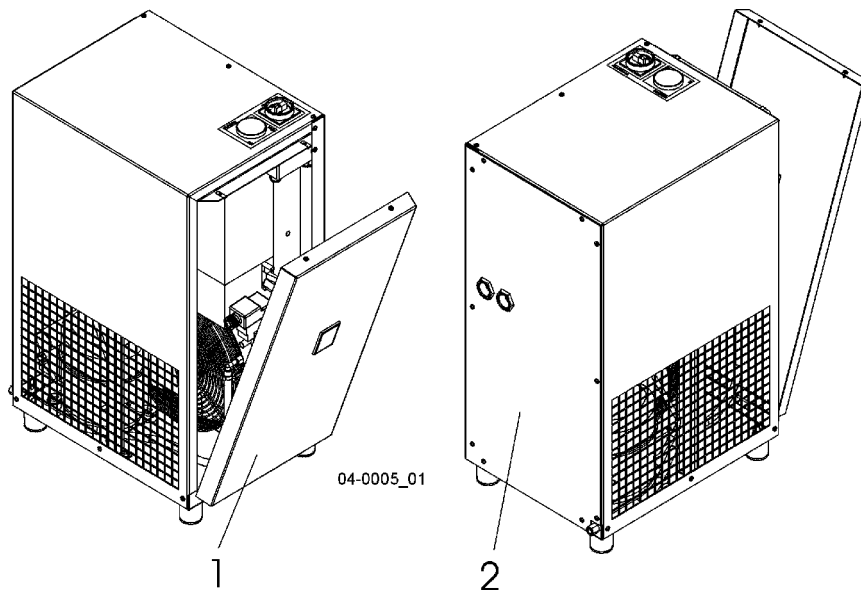

*Fig. 2 Cabinet*

1 Panel

2 Rear panel

The cabinet, when closed, serves various functions:

- sound damping
- protection against contact
- cooling air flow control

Safe and reliable operation is only assured with the cabinet closed.

To open the cabinet, loosen the retaining screws in the front and side panels with a screwdriver and remove the panels.

## 4.2 General Design

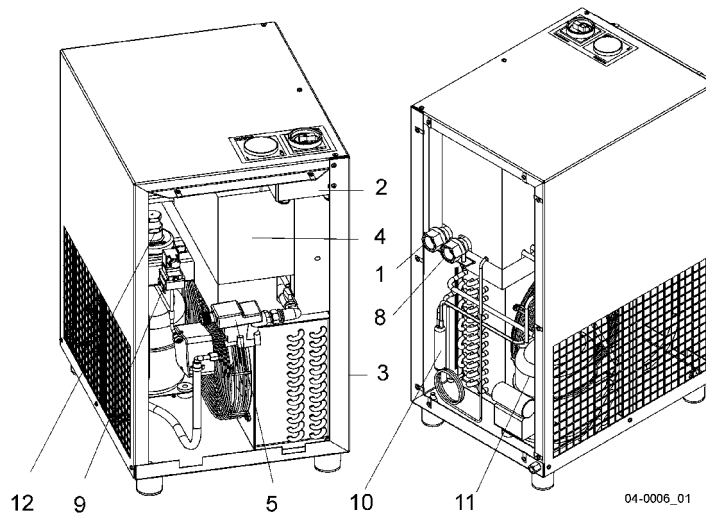

Fig. 3 Machine overview

- |                         |                           |
|-------------------------|---------------------------|
| 1 Compressed air inlet  | 8 Compressed air outlet   |
| 2 Control cabinet       | 9 Safety pressure switch  |
| 3 Refrigerant condenser | 10 Filter/dryer           |
| 4 Heat exchanger        | 11 Refrigerant compressor |
| 5 Condensate drain      | 12 Hot gas bypass valve   |

The main component in a refrigeration dryer is a combination heat exchanger (4).

A condensate separating system (5) is fitted downstream of the heat exchanger.

A safety pressure switch (9) is fitted in the refrigerant circulation system as a protection against excessive pressure.

A thermal overload switch protects the refrigerant compressor (11) against current overloads and overheating.

## 4.3 Function

The cooling action of the refrigeration dryer causes moisture to precipitate out of the compressed air.

Hot compressed air entering the dryer is pre-cooled by cold air leaving the dryer in the first section of the heat exchanger (4).

The compressed air is further cooled by gassing refrigerant in the air/refrigerant section of the heat exchanger (4). This cooling action causes the water vapour in the compressed air to condense when the temperature falls below the pressure dew point.

A condensate separator (5) downstream separates the condensed liquid from the air flow and drains it out of the system, together with oil droplets and larger dirt particles, via a condensate drain.

The hot gas bypass valve (12) regulates refrigerating capacity.

#### 4.4 Safety Devices

The following safety devices are provided and may not be modified:

- **EMERGENCY STOP**  
The ON/OFF switch shuts down the machine immediately.  
It can be fitted with a padlock to prevent reapplication of power.
- **Safety pressure switch**  
The safety pressure switch protects the refrigerant circuit against excessive pressure.  
It is factory set.  
If the safety pressure switch has actuated, the refrigeration dryer cannot be put back into operation until the manual RESET on the safety pressure switch has been pressed.
- **Housings and covers for moving parts and electrical connections**  
protect against accidental contact.

#### 4.5 Pressure Dew Point Indicator

The pressure dew point indicator provides information on the operating state of the refrigeration dryer.

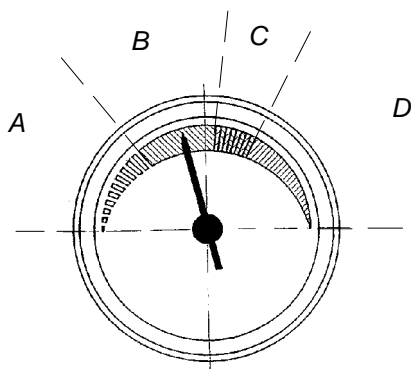

Fig. 4 Pressure dew point indicator

A Pressure dew point too low

B Pressure dew point normal

C Pressure dew point too high

D Pressure dew point too high

##### 4.5.1 Recognising the operational state

A complete list with instructions on fault rectification is given in chapter 9 "Faultfinding and removal".

The colour of the dew point indicator provides information on possible operating faults:

Zone	Colour	Meaning
A	blue/white	Danger of icing up Ambient temperature too low
B	green	Optimum operating conditions
C	green/red	Ambient and/or compressed air temperature too high
D	Red	Fault

Tab. 9 Indication

## **4.6 Accessories**

### **4.6.1 Bypass line (see chapter 6.5)**

The refrigeration dryer can be isolated from the air main with the bypass line. The air supply is maintained, however, no drying can take place.

## 5 Installation and Operating Conditions

### 5.1 Surroundings

- No open flames or sparks at the place of installation.
- Ensure that flying sparks or excessive temperatures during welding work on the machine are not a fire hazard.
- The machine is not explosion-proof.  
Do not operate in areas in which specific requirements with regard to explosion protection are applied.
- clean inlet air with no damaging contaminants,
- inlet air free of explosive or chemically unstable gases or vapours,
- inlet air free of acid-forming substances, particularly ammonia, chlorine or hydrosulphide.
- Keep surrounding temperatures within recommended limits.
- Keep suitable fire extinguishing material on hand.

### 5.2 Installation Conditions

#### 5.2.1 Place of installation and space required

- The floor must be level, firm and capable of bearing the weight of the equipment.
- Do not install the machine in the exhaust air flow from other machines.
- If installed outdoors, the equipment must be protected from frost, direct sunlight, dust and rain.



Values given are minimum guide values.

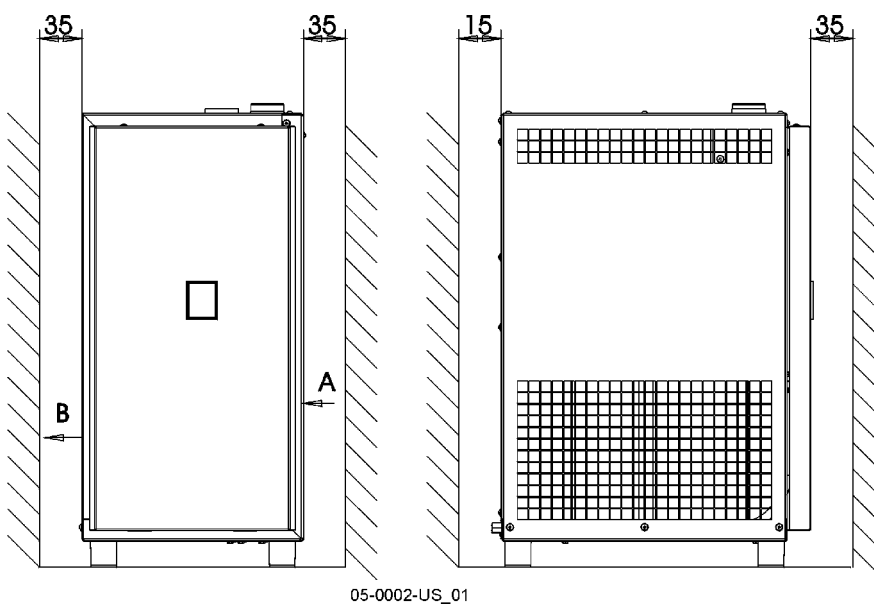

Fig. 5 Installation recommendation, dimensions [in]

- A Cooling air inlet
- B Cooling air outlet

**5.2.2 Operating in a compressed air system**

When the machine is connected to an air system, the operating pressure must not exceed 230 psig.

Initial filling of a fully vented air system generally creates a very high rate of flow through air treatment devices. These conditions are detrimental to correct air treatment. Air quality can be degraded.

To ensure maintenance of desired air quality when filling a vented air system we recommend the installation of an air main charging system.

Please contact KAESER for assistance in selecting and installing an air main charging system.

## 6 Installation

### 6.1 Safety

**DANGER**

#### Refrigerant

There is considerable risk of injury from released refrigerant if the refrigerant circuit is incorrectly opened.

- ✎ Do not open the refrigerant circuit.



All functional parts are factory set.

Changes may not be made without the permission of the manufacturer.

Installation may only be carried out by persons fully conversant with the basic safety concepts of refrigeration dryers.

### 6.2 Reporting Transport Damage

- ✎ Check the machine for visible and hidden transport damage.
- ✎ Inform the carrier and the manufacturer in writing of any damage.

### 6.3 Remove Transport Securing Device

A securing device is used to protect the machine from transport damage and this can not withstand heat.



Retain the securing device for further transport use.

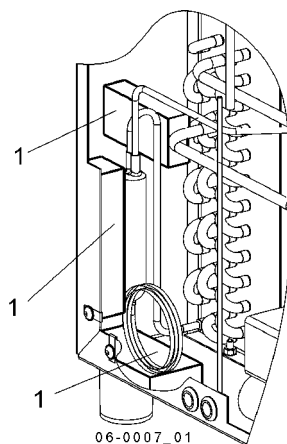

Fig. 6 Remove Transport Securing Device

1 Transport securing device

- ✎ Remove and retain the transport securing device.



## 6.4 Compressed Air Connection

**Pre-condition:** The air main is at atmospheric pressure.

### 6.4.1 Shut-off valves:



Take care during installation that no strain, pressure or bending forces are acting upon the compressed air connections.

☞ Install user's shut-off valves on the compressed air inlet and outlet.

## 6.5 Bypass line (accessory)

### 6.5.1 Bypassing the refrigeration dryer (when required)

**Pre-condition:** Machine switched off.  
Machine fully vented (no pressure).  
Shut-off valve to the air network closed.

#### Operation without bypass line

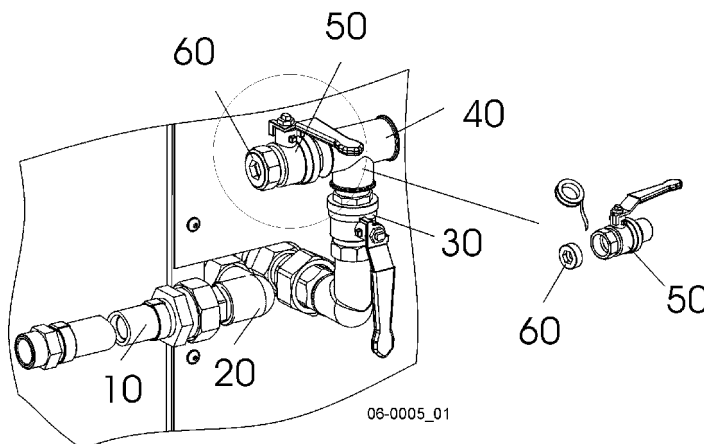

Fig. 7 Operation without bypass line

10	Hose	40	T-piece
20	Elbow – compressed air inlet	50	Ball valve
30	Ball valve	60	Plug



Observe the position of the valve operating lever.

- ☞ Screw the elbow (20) into the compressed air inlet and connect the hose (10).
- ☞ Attach the bypass components (items 30, 40 and 50) to the compressed air outlet.
- ☞ Bind the thread with sealing tape and screw the plug (60) into the ball valve (50).

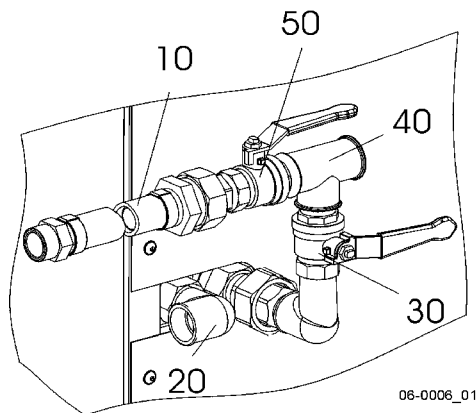
**Operating with bypass line**

**Fig. 8**      *Operating with bypass line*

10	Hose	40	T-piece
20	Elbow – compressed air inlet	50	Ball valve
30	Ball valve		



Observe the position of the valve operating lever.

- ☞ Remove the plug (60 Fig.7) from the ball valve (50).
- ☞ Unscrew the hose (10) from the elbow (20) and screw it into the ball valve (50).

## 6.6 Condensate Drain Line Connection



Collect condensate in a suitable container and dispose of in accordance with environmental regulations.

A hose connection is provided for condensate drainage.

Larger cross-sections should be used on condensate lines of 5m or longer.

- ☞ Connect the drain hose

## 6.7 Electrical Connection

Have the electrical connection made only by a qualified and authorized electrician.

Main power supply and overcurrent protection must be installed by a qualified electrician in accordance with NEC, OSHA, and any applicable local codes.

Use wire conductor dimensions and fuse ratings in accordance with local regulations. Guide values are given in chapter 2.6.

The machine is supplied with a 6 ft. connecting cable without plug.

- ☞ Have an authorized electrician fit a plug or make a fixed connection.
- ☞ Use an external isolating or autotransformer for an alternative mains voltage if necessary.

## 7 Initial Start-up

### 7.1 Safety



**DANGER**

#### **Voltage!**

Contact with live electric components can cause serious injury or death.

- ☞ Isolate all phases of the main power supply. (switch off the mains supply disconnecting device)
- ☞ Ensure that the power supply cannot be switched on again (locked off).
- ☞ Check that no voltage is present.



**WARNING**

#### **Uncontrolled discharge of compressed air!**

Serious injury or death can result from loosening or opening components under pressure.

- ☞ Close shut-off valves or otherwise isolate the machine from the compressed air system to ensure that no compressed air can flow back into the machine.

### 7.2 To be Observed Before Every Initial Start-up

Initial start-up of the machine may only be carried out by trained and authorized installation or maintenance personnel.

Incorrect or improper initial start-up can cause injury to persons or damage to the machine.

#### **Special measures:**

Do not start up the refrigeration dryer before its temperature corresponds to the ambient temperature.

### 7.3 Checking Installation and Operating Conditions

Carry out all the items in the checklist before starting the machine.

	<b>To be checked</b>	<b>Chapter</b>	<b>Done?</b>
1	☞ Are all the conditions for installation fulfilled?	5	
2	☞ User's lockable supply disconnecting device installed?	6.7	
3	☞ Is the power supply as specified on the nameplate?	2	
4	☞ Supply cable section and fuse rating adequate?	2.6.2	
5	☞ All electrical connections checked for tightness?		
6	☞ Shut-off valve fitted to the compressed air connections?	6.3	
7	☞ Condensate drainage checked for correct function?	10.2.3	
8	☞ Are the operators fully conversant with safety regulations?		
9	☞ Are all access doors closed and all removable panels in place and secured?	4.1.1	

Tab. 10 Installation conditions checklist

#### **7.4 Starting the Machine for the First Time**

- ☞ Open the shut-off valve to the compressed air system.
- ☞ Switch on the machine.

The refrigeration compressor starts and after a short period the machine cools the compressed air.

Watch for any faults occurring during the first few hours of operation.

## 8 Operation

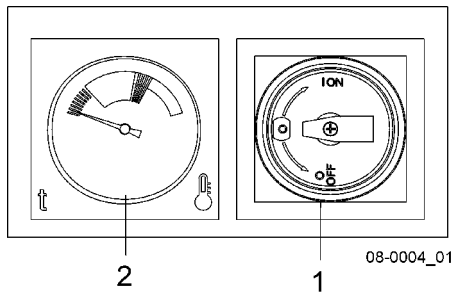

Fig. 9 Switching on and off

- 1 On/off switch
- 2 Pressure dew point indicator

### 8.1 Switching On and Off



#### Compressed air!

**WARNING**

Serious injury is possible.

- ☞ Never direct compressed air at persons or animals.

#### 8.1.1 Switching on

- ☞ Ensure that:
  - no one is working on the machine,
  - all panels are in place.
  - all access doors are closed.
- ☞ Switch on the supply disconnecting device.
- ☞ Turn the switch (1) to ON.

The refrigerant compressor starts.

#### 8.1.2 Starting the machine after a fault

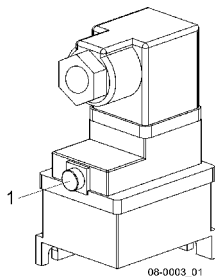

Fig. 10 RESET

- 1 RESET

- ☞ Press RESET if the dryer has been shut down by the safety pressure switch.
- ☞ Turn the switch (1) to ON position.

#### 8.1.3 Switching off

- ☞ Turn the switch (1) to the OFF position and lock off.

## 9 Fault Finding and Removal

Inform KAESER Service if the fault cannot be removed by the measures suggested.

Do not attempt fault removal measures other than those given in this manual.

### 9.1 Faults

<b>Fault</b>	<b>Possible cause</b>	<b>Remedy</b>
Water in the compressed air system	Compressed air inlet and outlet reversed.	Check the compressed air inlet.
	The condensate is not draining out of the system.	Check and clean the condensate drain.
High pressure drop	Refrigeration dryer iced up at the air end.	Shut down the dryer until the air system has thawed out.
	Continuous air loss from the condensate drain.	Clean the condensate drain.
Pressure dew point too high	Surrounding and/or compressed air inlet temperature too high.	Ensure that installation conditions are being kept to.
	Low refrigerant level.	Contact KAESER service.
	Dirt collecting in the compressed air system.	Contact KAESER service.
The safety pressure switch shuts down the dryer	Surrounding and/or compressed air inlet temperature too high.	Ensure that installation conditions are being kept to.
	Refrigerant condenser dirty.	Clean the refrigerant condenser.

Tab. 11 *Faults and Remedies*

## 10 Maintenance

### 10.1 Safety

Any disregard of these instructions and/or incorrect handling may result in serious injuries.



**DANGER**

#### Voltage!

There is danger of fatal injury caused by touching electrically live components.

- ☞ Isolate all phases of the main power supply. (switch off the mains supply disconnecting device)
- ☞ Ensure that the power supply cannot be switched on again (locked off).
- ☞ Check that no voltage is present.



**WARNING**

#### Refrigerant

Danger of injury from refrigerant.

- ☞ Do not open or dismantle the refrigerant circuit.



Maintenance intervals are recommendations only and should be adjusted to suit installation and operating conditions.

Before switching on again ensure that:

- no maintenance personnel are working on the machine,
- all panels are in place and secured,
- all access doors are closed.

### 10.2 Regular maintenance work

Interval	Maintenance tasks
weekly	Functional check of condensate drainage.
monthly	Clean the surface of the refrigerant condenser.
quarterly	General checks.
	Cleaning the condensate drain.

#### 10.2.1 General checks.

- ☞ Check the refrigeration dryer's electrical equipment. Immediately repair any defects, such as loose connections and/or overheated cables.
- ☞ Check all pipes, hoses and fittings for leaks and any visible damage. Immediately repair any faults.

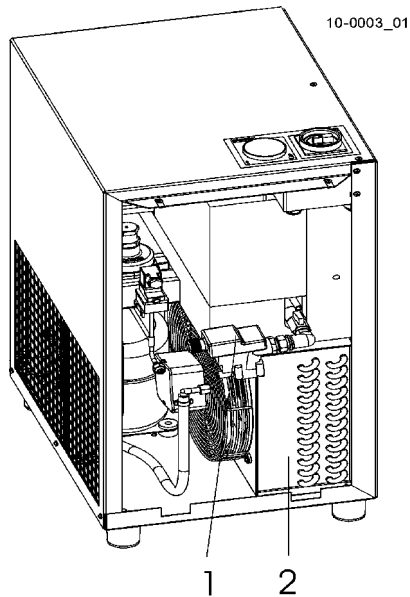
**10.2.2** Cleaning the refrigerant condenser

*Fig. 11*      *Cleaning the refrigerant condenser and condensate drain*

- 1      *Condensate drain*
- 2      *Refrigerant condenser*

**Equipment:**      Compressed air for blowing out  
                          Cleaning rags  
                          Water with cleaning agent additive

**Pre-condition:**    Machine switched off.  
                          Supply disconnecting device switched off and locked out.  
                          Machine cooled down.

- ☞ Blow out the refrigerant condenser (2) with compressed air (< 70 psig), clean off heavy fouling with water.



### 10.2.3 Checking condensate drainage

**Pre-condition:** Machine running.

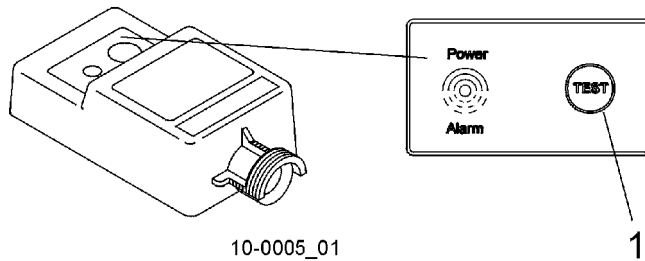

Fig. 12 Testing the condensate drain

1 TEST button

☞ Check visually that condensate flows from the drain hose.

#### **Condensate does not drain out?**

The condensate drain hose is clogged.

☞ Switch off the machine and clean or replace the drain hose.

#### **Condensate does not drain out?**

Condensate drain blocked.

☞ Clean the condensate drain.

**10.2.4 Cleaning the condensate drain**

**Equipment:** Compressed air for blowing out  
 Cleaning rags  
 Spare parts (as required)

**Pre-condition:** Machine switched off.  
 Supply disconnecting device switched off and locked out.  
 Close the shutoff valve in the line to the ECO DRAIN.  
 Machine cooled down.

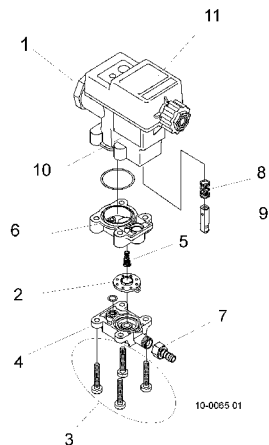

**Fig. 13**      *Cleaning the condensate drain*

1	<i>Inlet fitting</i>	7	<i>Drainage fitting</i>
2	<i>Diaphragm</i>	8	<i>Compression spring (valve core)</i>
3	<i>Screw</i>	9	<i>Valve core</i>
4	<i>Diaphragm seat</i>	10	<i>Housing</i>
5	<i>Compression spring (diaphragm)</i>	11	<i>Panel</i>
6	<i>Diaphragm cover</i>		

**Dismantling the condensate drain**

- ☞ Close the shut-off valve upstream of the condensate drain.
- ☞ Unscrew the condensate drain hose fitting (7).
- ☞ Remove the securing screws (1) and remove the drain.

**Cleaning the condensate drain**

- ☞ Unscrew the securing screws (3) and remove the diaphragm seat (4).
- ☞ Take out and clean the compression springs (5 and 8), the diaphragm (2) and the valve core (9).
- ☞ Renew damaged or worn parts.
- ☞ Blow out the housing with compressed air (< 70 psig).
- ☞ Reassemble and check correct seating of spring and diaphragm.

**Replacing the condensate drain**

- ☞ Connect the condensate drain hose to the male stud fitting (1).
- ☞ Re-connect the drain hose fitting and open the shut-off valve.
- ☞ Close all access doors; replace and secure all removable panels.



## 11 Spares, Operating Materials, Service

### 11.1 Note the nameplate

Please quote the data on the nameplate for all enquiries and spare parts orders.

### 11.2 Ordering Consumable Parts and Operating Materials



**CAUTION**

**Personal injury or damage to the machine may result from the use of unsuitable spare parts or operating materials.**

Unsuitable or poor quality consumable parts and operating materials may damage the machine or impair its proper function.

Damage to the machine can also result in personal injury.

- ☞ Use only genuine spare parts and operating materials quoted.
- ☞ Have an authorised KAESER service agent carry out regular maintenance.

KAESER consumable parts and operating materials are genuine spares. They are designed for use in our machines.

### 11.3 Maintenance Agreement

- ☞ Concluding a SIGMA AIR SERVICE maintenance agreement.

Benefits to you:  
lower costs and assured availability of compressed air.

SIGMA AIR SERVICE offers you:

- authorized service technicians with KAESER factory training,
- increased operational security by preventive maintenance,
- energy savings by elimination of pressure losses,
- optimum conditions for operation of the compressed air supply system,
- the security of genuine KAESER spare parts.
- increased legal security as all regulations are observed,

### 11.4 Service Addresses

Addresses of KAESER distributors are given at the end of this manual.

### 11.5 Spare Parts for Service and Repair



Any inspection, maintenance or repair tasks not described in this manual should be carried out only by an authorized KAESER distributor.

With the help of this parts list you can obtain in advance the spares you need in accordance with your operating conditions.

## Ersatzteilliste

Kältetrockner Typ TCH

## Spare parts list

Refrigeration dryer series TCH

## Liste de pièces de rechange

Sécheur frigorifique Type TCH

## Lista de las piezas de recambio

Secador frigorífico modelo TCH

## Lista parti di ricambio

Essiccatore a ciclo frigorifero serie TCH

## Reservedelsliste

Kjøletørke type TCH

## Перечень запасных частей

Холодосушителем типа TCH

## スเปアパーツリスト

冷凍式ドライヤーモデル TCH

Typ  
Model  
Type  
Modelo  
Modello  
Тип  
モデル

**KAESER**  
<http://www.kaeser.com>  
Dok.Nr. SEL-1196\_01D

Materialnummer  
Part number  
Référence  
Número material  
Codice  
Номер материала  
部品番号

Serialnummer  
Serial number  
No. de série  
Número de serie  
Número di serie  
Серийный номер  
シリアルナンバー

### ACHTUNG !

Bitte geben Sie bei der Ersatzteilbestellung Material- und Serialnummer der Anlage sowie Positionsnummer und Bezeichnung der Ersatzteile an.

### ATTENTION !

Please quote the part number and serial number of the package together with the item number and the description of the part when ordering.

### ATTENTION !

Indiquer sur chaque commande de pièces de rechange la référence et le No. de série de l'appareil, de même que le No. du repère et la désignation de la pièce de rechange.

### ¡ ATENCION !

Cuando pidan piezas de recambio les rogamos nos indiquen el número de material y de la serie, así como el número de la posición y la designación de las piezas de recambio.

### ATTENZIONE !

Nell'ordinazione si prega di indicare il codice, il numero di serie, il numero di posizione e la descrizione del pezzo di ricambio.

### OBS!

Ved reservedelsbestillingar må dei opplyses om anleggets artikkel- og serienummer, i tillegg til posisjonsnummer og reservedels betegnelse.

### ВНИМАНИЕ !

При заказе запасных частей указывайте номер изделия и серийный номер установки так и номер позиции и наименование запасных частей.

### 注意！

後注文時には、図の No. と部品名、コンプレッサーの製品番号とシリアルナンバーを併記して下さい。

TCH

KAESER

Dok.Nr SEL-1196\_01D

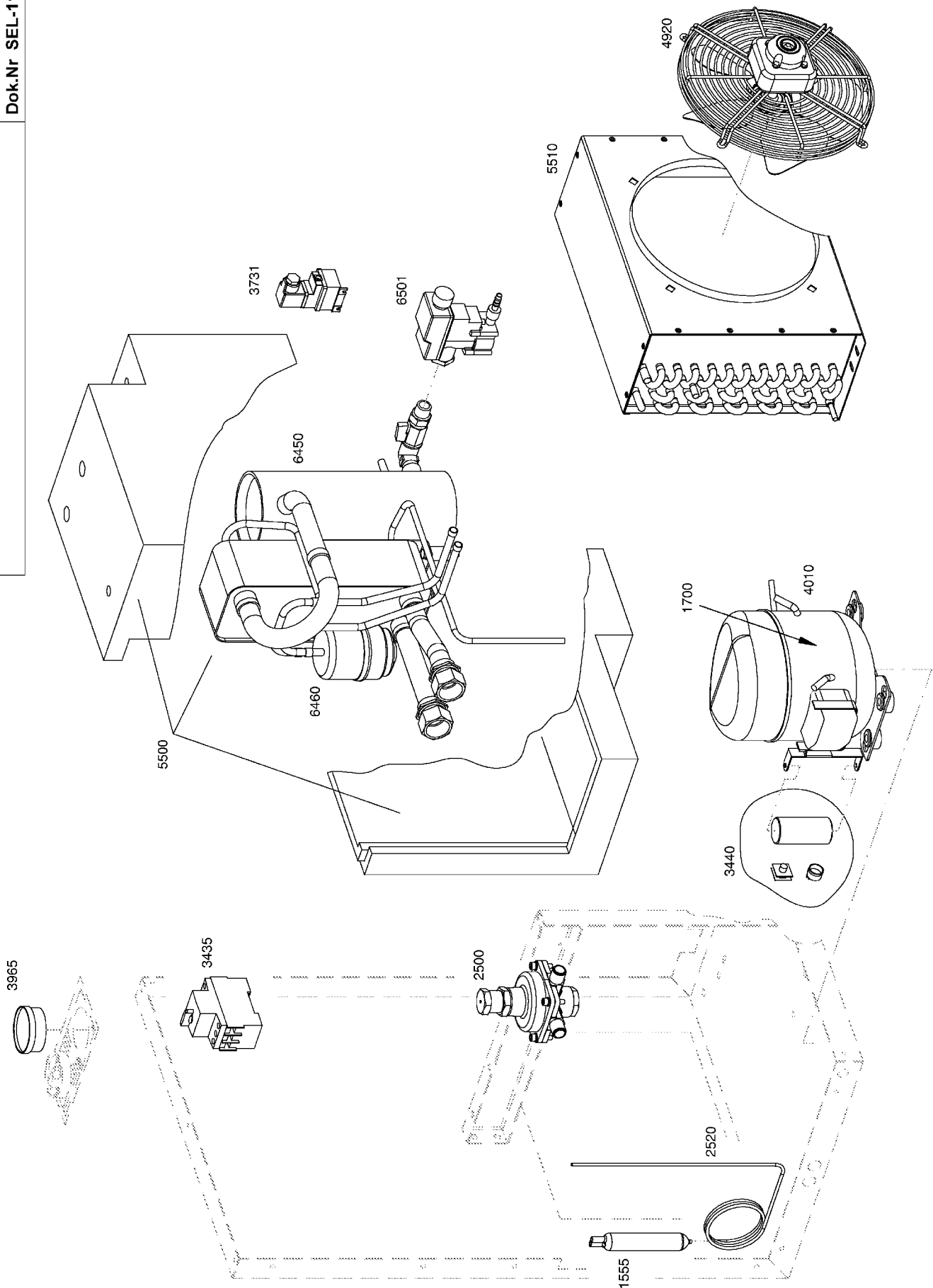

Nr./No.	Stck/Qty	Bezeichnung	Description	Désignation	Designación
1555	1	Filterrockner	Filter dryer	Flitre sécheur	Filtro secador
1700	1	Kältemittel	Refrigerant	Fluide frigorigène	Fluido refrigerante
2500	1	Heißgas-Bypass-Regler	Hot gas bypass controller	Régulateur bypass gaz chaud	Regulador bypass gas cal.
2520	1	Kapillarrohr	Capillary tube	Tube capillaire	Tubo capilar
3435	1	Motorschutzschalter	Motor protection switch	Relais de protection thermique du moteur	Relé térmico del motor
3440	1	Service Kit, elektr. Teile	Service kit, electr. parts	Service kit, Part.él.	Service kit, Part.el.
3731	1	Sicherheitsdruckschalter	Safety pressure switch	Pressostat de sécurité	Pressostat de seguridad
3965	1	Fernthermometer	Remote thermometer	Téléthermomètre	Control remoto temperatura
4010	1	Kältekompressor	Refrigerant compressor	Compresseur frigorifique	Compresor del refrigerante
4920	1	Lüftereinheit kpl.	Fan unit cpl.	Unité de ventilator cpl.	Unidad ventilador cpl.
5500	1	Wärmetauscher kpl.	Heat exchanger cpl.	Echangeur chaleur cpl.	Intercambiador de calor de placas cpl.
5510	1	Kältemittelverflüssiger kpl.	Refrigerant liquefier cpl.	Condenseur de frigorigène cpl.	Fluidificador del agente frigorífico cpl.
6450	1	Abscheidebehälter	Separator tank	Réservoir séparateur	Separador de depósito
6460	1	Flüssigkeitsabscheider	Liquid separator	Séparateur de liquide	Separador de líquidos
6501	1	Kondensatableiter	Condensate drain	Purgeur de condensat	Purgador de condensatos
9601	1	Verschleißteilsatz	Wearing part set	Kit pièces d'usure	Kit de desgaste
9603	1	Dichtungssatz	Seal set	Jeu de joints	Juego de juntas
9605	1	Membrane kpl.	Diaphragm cpl.	Diaphragme cpl.	Diaphragma cpl.

Nr./No.	Stck/Qty	Descrizione	Betegnelse	Наименование	部 品 名
1555	1	Filtero essiccatore	Filtertorke	Фильтровальный сушитель	フィルタードライヤー
1700	1	Fluido frigorigeno	Kjølemiddel	Хладагент	冷凍
2500	1	Valvola bypass dei gas caldi	Varmgass-bypass-regulator	Перегретый газ - регулятор (байпас)	ホットガスバイパスコントローラー
2520	1	Capillare	Kapillarrør	Капиллярная трубка	キャピラリー チューブ
3435	1	Klixon di protezione del motore	Motorvernbyrter	Расцепитель максимального тока	モーター保護スイッチ
3440	1	Kit manutenz., Parti el.	Servicesett, E-dele	Комплект обслуж.электр.деталей	電装品サービスキット
3731	1	Pressostato di sicurezza alta pressione	Sikkerhetsstrykkbryter	Предохранительн. манометрический выключатель	安全圧カスイッチ
3965	1	Termometro a distanza	Fjerntermometer	Дистанционный термометр	遠隔温度計
4010	1	Compressore del refrigerante	Kjølekompressor	Холодильный компрессор	冷凍コンプレッサー
4920	1	Unità ventilatore cpl.	Vifteenh. kpl.	Единство вентилятора в сборе	ファンユニット
5500	1	Scambiatore di calore compl.	Varmeveksler kpl.	Теплообменник в сборе	熱交換器
5510	1	Condensatore del refrigerante completo	Kjølemiddelfordamp. kpl.	Холодильный конденсатор в сборе	冷凍用液化装置
6450	1	Recipiente separatore	Sep.tank	Сборник	セパレータータンク
6460	1	Separatore liquidi	Væskeutskiller	Сепаратор жидкости	液体セパレーター
6501	1	Scaricatore di condensa.	Kondensatavleder	Конденсатоотводчик	凝縮水排出装置
9601	1	Set parti soggette a usura	Slitedelssett	Комплект быстрознашивающихся деталей	消耗部品セット
9603	1	Set di guarnizioni	Pakningssett	Комплект уплотнений	シール、セット
9605	1	Membrana compl.	Membran kpl.	Мембрана в сборе	ダイヤフラム



...  
 Betr-h / Serv-h /  
 horas de servicio / h serv. /  
 Driftst. / Рабоч. Часы /  
 運転時間

Wartungspaket / Maintenance package /  
 Package d'entretien / Paquete de mantenimiento /  
 Kit di manutenzione / Vedlikeholdspakke /  
 Комплект быстроизнашивающихся деталей / Менテナンスキット

<b>A</b>	
Nr. / No.	Stück / Qty.
9603	1
9605	1

<b>B</b>	
Nr. / No.	Stück / Qty.
9601	1

Wartungspaket / Maintenance package  
 Package d'entretien / Paquete de mantenimiento  
 Kit di manutenzione / Vedlikeholdspakke  
 Комплект быстроизнашивающихся деталей / Менテナンスキット

DE	Wartungspakete Kältetrockner Typ TCH	<b>KAESER</b>
EN	Maintenance packages refrigeration dryer series TCH	
FR	Paquets d'entretien sécheur frigorifique Type TCH	
ES	Paquetes de mantenimiento secador frigorífico modelo TCH	
IT	Kit di manutenzione per il essiccatore a ciclo frigorifero modello TCH	
NO	Vedlikeholdspakke kjøletørke type TCH	
RU	Комплект быстроизнашивающихся деталей для холодильителя типа TCH	Dok.Nr.
JA	メンテナンスキット 冷凍式ドライヤーモデル TCH シリーズ	<b>SEL-1196_01D</b>

Vor und bei Ausführung aller Arbeiten sind die Sicherheits- und Servicehinweise in der Betriebsanleitung der Maschine zu beachten!  
 Before and during all work, be sure to read and follow the safety and service instructions contained in the machine Service Manual!  
 Avant et lors de l'exécution de travaux, il est impératif de respecter les consignes de sécurités et de maintenance décrites dans la notice d'utilisation de la machine.  
 ¡Se ruega observar las indicaciones de seguridad y mantenimiento en las instrucciones de servicio de la máquina antes de efectuar cualquier trabajo y durante el mismo!  
 Prima e durante ogni lavoro si raccomanda di osservare tutte le norme di sicurezza e le istruzioni d manutenzione contenute nel manuale di servizio della macchina!  
 Både før og efter gjennomføring av vedlikeholds-arbeid, må maskinens sikkerhets- og service-anvisninger følges nøye (finnes i driftsinstruksen)!  
 Перед и во время всех работ должны соблюдаться указания по безопасности и сервису в Инструкции по эксплуатации!  
 すべてのメンテナンス作業中・前には、機械のサービスマニュアルの安全規則を守り、メンテナンスの注意事項に注意して下さい。



## 12 Decommissioning, Storage and Transport

### 12.1 Decommissioning

It is necessary to decommission the machine if:

- it will not be needed for a short time,
- it is to be moved to another location,
- it is no longer needed,
- it is to be scrapped.

#### Temporarily decommissioning

- ☞ Drain condensate.
- ☞ Shut off all air connecting lines and isolate the machine from the power supply.

#### Permanently decommissioning

- ☞ Drain condensate.
- ☞ Shut off all air connecting lines, vent air pressure and isolate the machine from the power supply.
- ☞ Allow the machine to cool down completely.
- ☞ Disconnect all air and electrical connections.

### 12.2 Packaging

**Equipment:** Desiccant  
Plastic sheeting  
Wooden transport crate

**Pre-condition:** Machine is decommissioned.  
Machine is dry and cooled down.

- ☞ Place desiccant inside the machine cabinet.
- ☞ Fit transport securing device (Fig. 6)
- ☞ Wrap the machine in plastic sheeting.

#### Transport packaging

A wooden crate is required for overland transport to protect the machine from mechanical damage.

Consult an authorized KAESER distributor for advice on packaging for sea or air transport.

### 12.3 Storage

**Pre-condition:** The machine must be adequately packed.

- ☞ Store the machine in a dry room where the temperature remains above 32 °F.
- ☞ Prevent ingress of moisture and condensation.

## 12.4 Transportation

**Pre-condition:** The machine must stand completely on a pallet or wooden base.



### CAUTION

**Machine damage from incorrect transport.**

- ☞ Do not lift by the compressed air inlet or outlet.
- ☞ Do not lay the machine on its side.

Transport only by fork truck operated only by personnel trained and authorized in the safe use of the transport equipment.



Make sure to empty the condensate drain in frosty conditions.

- ☞ Make sure the danger zone is clear of personnel during transporting.

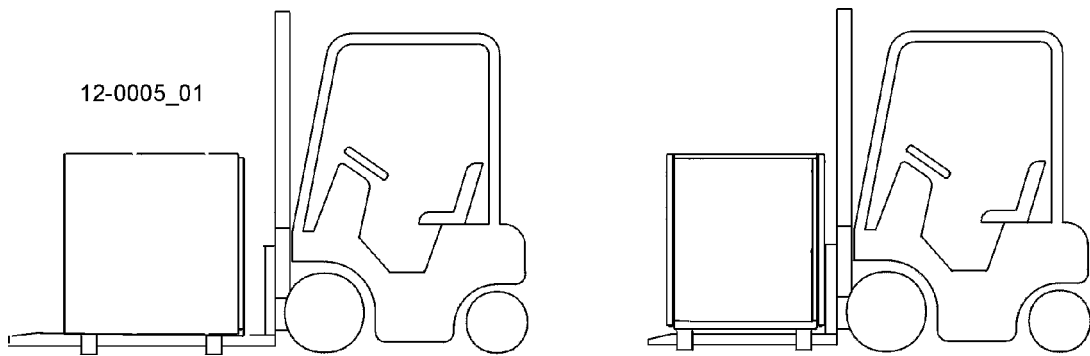

Fig. 14 Transport using a fork lift truck

## 12.5 Disposal

**Pre-condition:** The machine is decommissioned.



The sealed refrigerant circuit still contains both refrigerant and oil. Both must be drained and disposed of by an authorized body.

## **13 Annex**

### **13.1 Diagrams and Drawings**

#### **13.1.1 Pipeline and instrument flow diagram (P&I diagrams)**





13.1.2 Dimensional Drawing

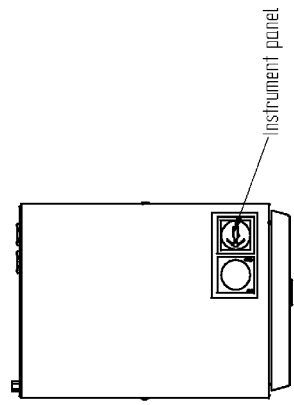
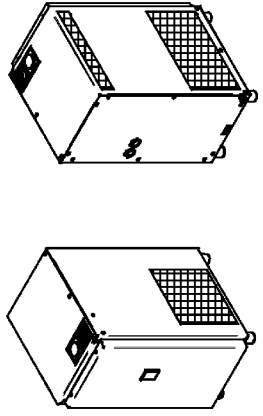
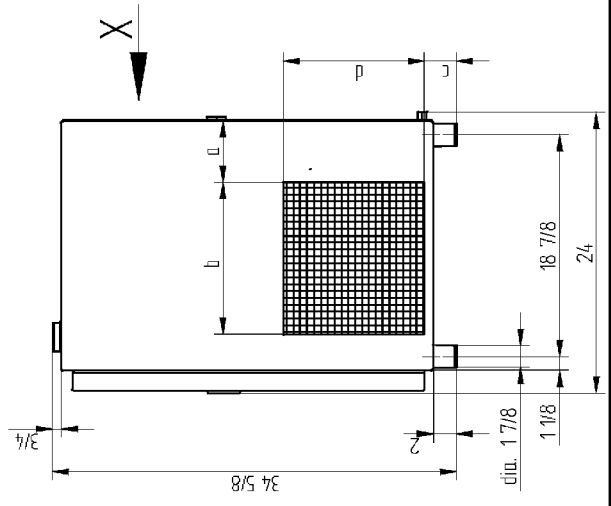
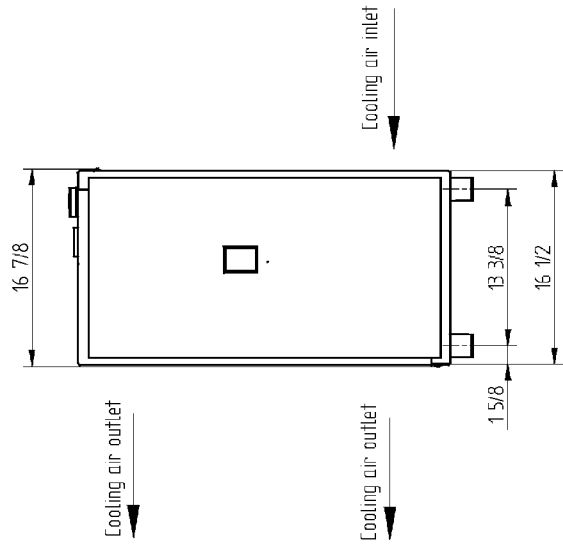
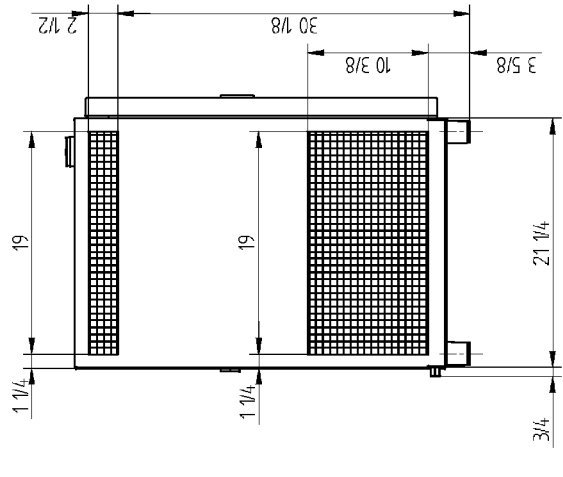
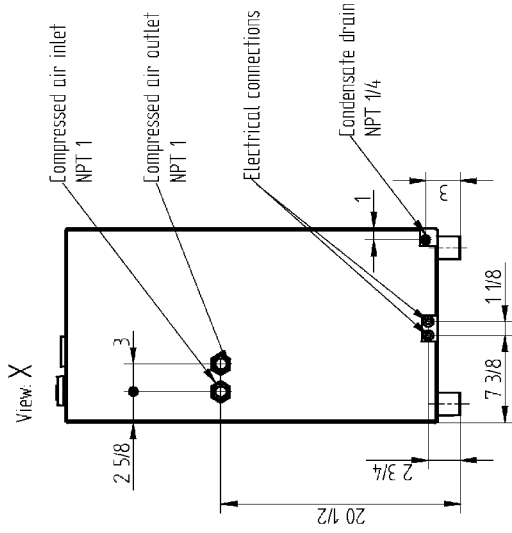

View X

Die Abmessungen sind in Zoll angegeben. Die Abmessungen sind in Zoll angegeben. Die Abmessungen sind in Zoll angegeben.

Die Zeichnung liefert in der unvollständigen Ausführung. Sie sind nur zu dem Zweck herzustellen, die Zeichnung zu überprüfen. Keine anderen Zwecke werden. Kopieren oder sonstige Vervielfältigungen sind nicht zulässig. Nachdruck, Verbreitung oder Verbreitung unter Verwendung elektronischer Systeme ist ohne schriftliche Genehmigung des Herstellers ist nicht zulässig. Weiterhin ist die Weitergabe der Zeichnung an Dritte ohne schriftliche Genehmigung des Herstellers ist nicht zulässig. Die Abmessungen sind in Zoll angegeben. Die Abmessungen sind in Zoll angegeben. Die Abmessungen sind in Zoll angegeben.

All dimensions are in inches!

**KAESER**  
KOMPRESSOREN  
T10524.00 Use  
A-Index 02

TCH 22-35		Einsatz: für	
Typ	Körpertyp	Druck	Druck
Bezeichnung	C205.05	Druck	Druck
Druck	13.05.2005	Druck	Druck
Druck	13.05.2005	Druck	Druck
Druck	13.05.2005	Druck	Druck
Druck	13.05.2005	Druck	Druck

	a	b	c	d
TCH 22 / 26 / 32	4 5/8	13 3/4	2 3/4	11 1/8
TCH 35	5 1/4	12 7/8	2 3/4	12 1/8

13.1.3 Electrical diagram



1	2	3	4	5	6	7	8	
<div style="border: 1px solid black; padding: 20px; text-align: center;"> <p><b>Wiring Diagram</b></p> <p><b>refrigeration dryer series TCH</b></p> <p><b>230V 50/60Hz (CY)</b></p> <p><b>115V 60Hz (CY)</b></p> <p><b>TT/TN power supply with common point grounding</b></p> </div>								
<p><b>manufacturer: KAESER KOMPRESSOREN GmbH</b></p> <p><b>96450 Coburg</b></p> <p><b>GERMANY</b></p>								
<p>The drawings remain our exclusive property. They are entrusted only for the agreed purpose. Copies or any other reproductions, including storage, treatment and dissemination by use of electronic systems must not be made for any other than the agreed purpose. Neither originals nor reproductions must be forwarded or otherwise made accessible to third parties.</p>								
c		Datum	30.09.2004	USE	cover page			=
b		Bearb.	Sifler		refrigeration dryer TCH			+
a		Gepr.	Gegner		DTCH-00950.00			
A	Änderung	Datum	Name	Norm	Kaeser KOMPRESSOREN			Blatt 1
				Ersatz durch:	Ersatz für:			Bl.
				Ursprung:				







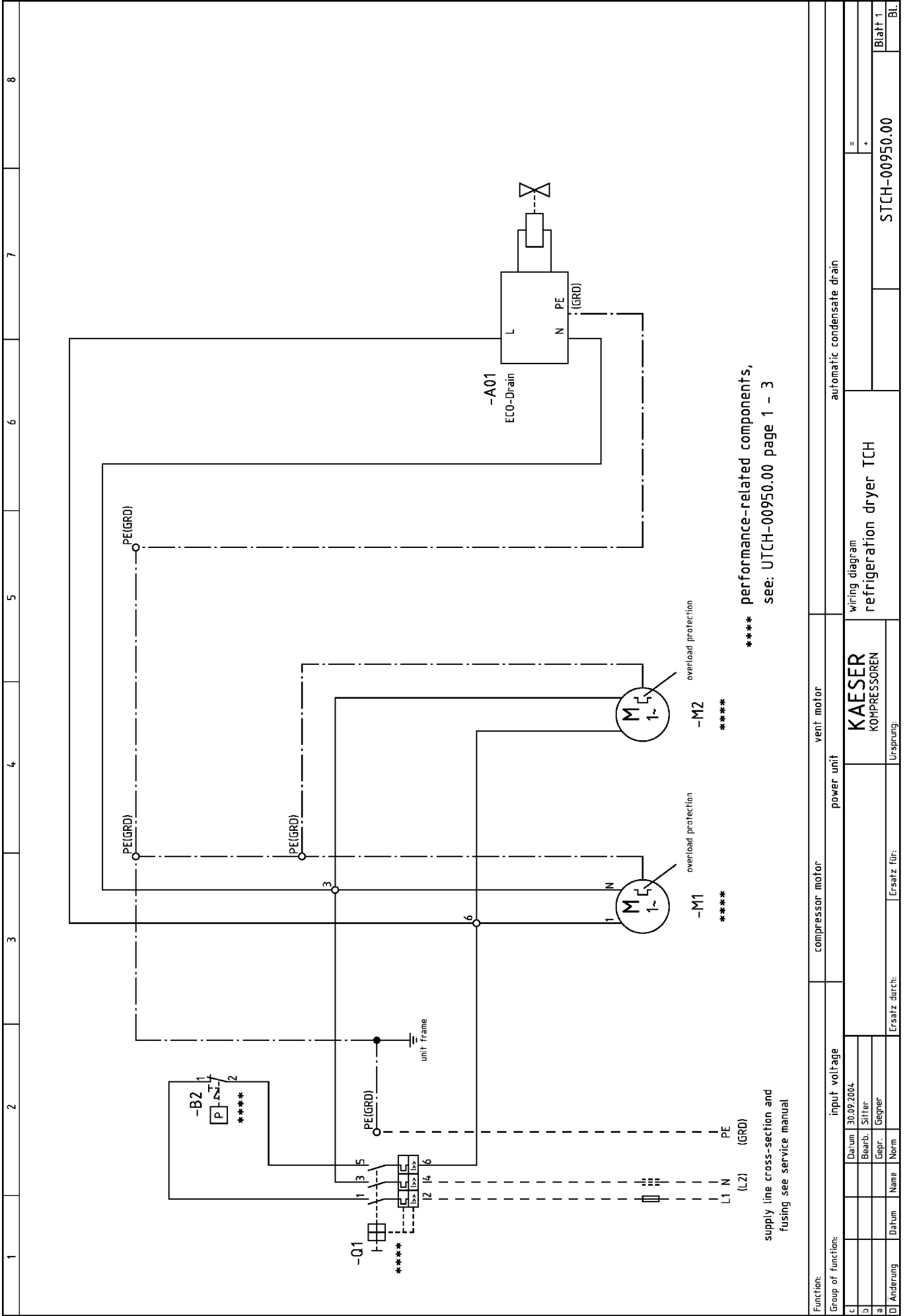

\*\*\*\* performance-related components,  
see: UTCH-00950.00 page 1 - 3

supply line cross-section and  
fusing see service manual

Function:		input voltage		compressor motor		power unit		vent motor		automatic condensate drain	
Group of function:		input voltage		compressor motor		power unit		vent motor		automatic condensate drain	
1		Datum	30.09.2004								
2		Bearb.	Sifler								
3		Gepr.	Gegner								
4		Datum	Name	Norm							
5		Ersetzung durch:		Ersetzung für:							
6											
7											
8											
										wiring diagram	
										refrigeration dryer TCH	
										=	
										+	
										STCH-00950.00	
										Blatt 1	
										BL	