

Internal Use Only
3151682a / 050314

INSTRUCTION MANUAL

**Models: OME125, OME250, OME500,
OME1100, OME1500, OME2100,
OME2400, OME3000**

CONTENTS

GENERAL SAFETY INFORMATION	2
RECEIVING INSTRUCTIONS	2
DESCRIPTION	2
1.0 INSTALLATION	2
2.0 OPERATION.....	5
3.0 MAINTENANCE	6
DIMENSIONS AND WEIGHTS.....	7
WARRANTY	8

KAESER

OME SERIES

MIST

ELIMINATOR

GENERAL SAFETY INFORMATION

A. Pressurized devices

This equipment is a pressure containing device

- Do not exceed maximum operating pressure shown on the serial number tag.
- Make sure equipment is depressurized before working on or disassembling for service.
- A pressure relief device must be added to the equipment.

B. Breathing air

- Air treated by this equipment may not be suitable for breathing without further purification.

Refer to OSHA standard 1910.134 for the requirements for breathing quality air.

RECEIVING INSTRUCTIONS

A. Receiving

This shipment has been thoroughly checked, packed, and inspected before leaving our plant. It was received in good condition by the carrier and was so acknowledged.

1. Check for visible loss or damage
If this shipment shows evidence of loss or damage at the time of delivery to you, insist that a notation of this loss or damage be made on the delivery receipt by the carrier's agent.
2. Check for concealed loss or damage
When a shipment has been delivered to you in apparent good order, but concealed damage is found upon unpacking, notify the carrier immediately and insist on his agent inspecting the shipment. Fifteen days from receipt of shipment is the maximum time limit for requesting such inspection. Concealed damage claims are not our responsibility as our terms are F.O.B. point of shipment.

DESCRIPTION

The Mist Eliminator is a coalescing type oil removal filter designed to remove oil and water aerosols from a compressed air system. It consists of a highly engineered, loosely packed, glass fiber filter cartridge housed in a heavy duty ASME stamped pressure vessel.

Compressed air is directed into the vessel and through the filter cartridge where entrained water and oil aerosols are captured by the fibers. The captured particles move along the fibers and coalesce into larger droplets which gravitate to the bottom of the cartridge. Here they fall into the vessel sump and are discharged from the system.

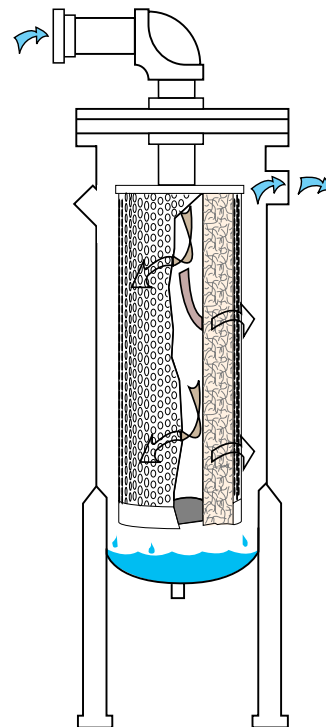

1.0 INSTALLATION

1.1 System cleaning

The compressed air system should be purged prior to the installation of the Mist Eliminator.

- Solid particles should be removed from upstream lines in order to prevent any loose dirt, rust, or scale from entering the filter and causing a premature increase in pressure drop.
- Residual oil should be flushed from downstream lines otherwise considerable time will be necessary before the desired air quality is available at the point-of-use.

1.2 Location in a compressed air system

Aftercooler/separator - It is strongly recommended that the Mist Eliminator be installed at a point where the compressed air is as cool as possible. In most cases the Mist Eliminator will have to be installed downstream of an aftercooler to provide an inlet temperature below the 150°F (65°C) maximum. While inlet temperatures as high as 150°F (65°C) are possible, this will allow some oil to remain a vapor and pass through the filter. Lower inlet temperatures (preferably below 120°F [49°C]) will have allowed more of the oil vapor present to condense into liquid droplets which can then be removed by the Mist Eliminator.

Refrigerated dryers - The Mist Eliminator should be installed downstream of a refrigerated dryer to remove any oil that may have condensed inside the dryer.

Desiccant dryers - The Mist Eliminator should be installed upstream of a desiccant dryer to prevent oil from contaminating the desiccant.

The distance between the Separator and Mist Eliminator must be minimized to avoid over loading with water. A drop in temperature from 110°F (43°C) to 105°F (41°C) will condense enough liquid water to overload the Mist Eliminator.

1.3 Service clearance

Make certain that clearance exists above the filter to allow removal and replacement of the filter cartridge.

1.4 Foundation

The Mist Eliminator can be installed on any flat, level floor with sufficient strength to support the required weight. Mounting holes are available for anchoring if desirable.

NOTE: Mount so that inlet and outlet connections are horizontal (vessel is vertical). Separated and coalesced liquids drain by gravity downwards through the cartridge and drop to and are collected in the filter sump. The vessel must be mounted nearly plumb vertically so that drainage will not be impeded and filtration efficiency reduced.

A typical installation will also include:

- ❶ Manual or Automatic Drains
- ❷ Differential Pressure Gauge
- ❸ Isolation Valves and by-pass piping

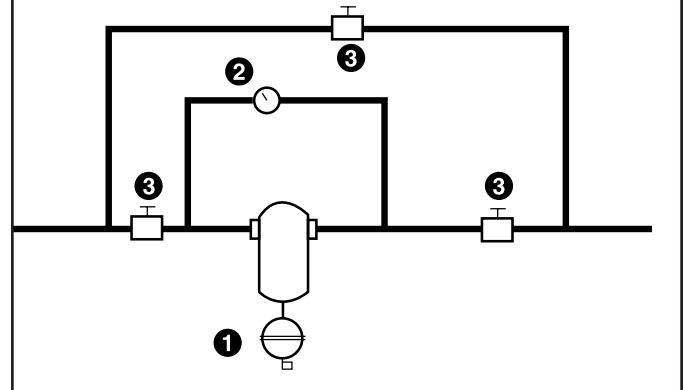

1.5 Connections

Connect inlet and outlet piping to the compressed air system.

NOTE: Flow Direction - Check to ensure that the air flow is in the proper direction as indicated on the vessel. Air flow direction through the filter cartridge must be from the inside out.

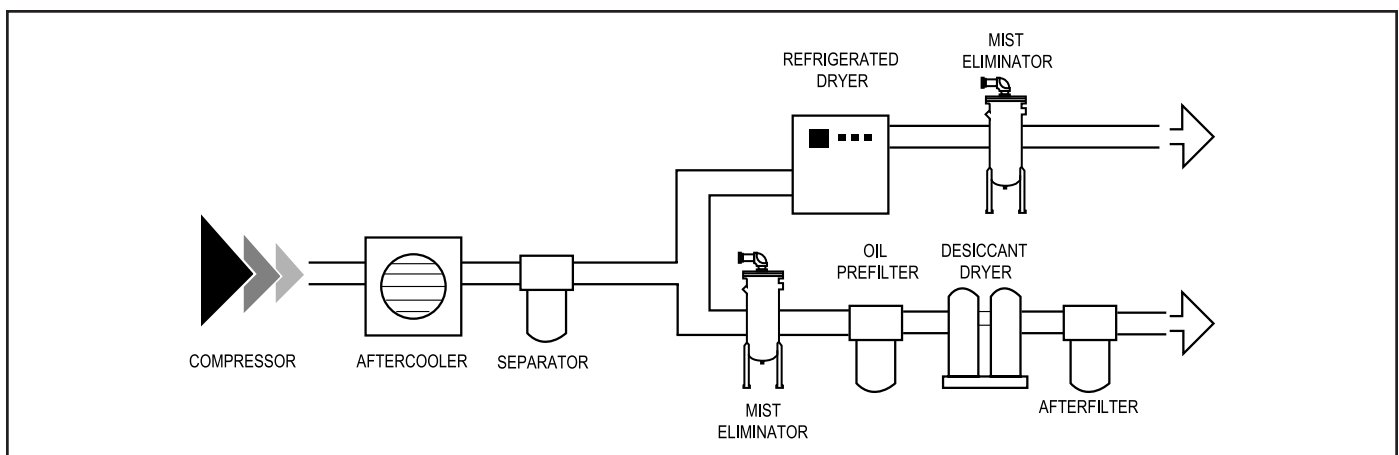
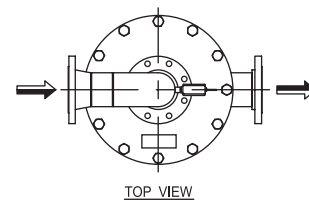

1.6 Drain provisions

The bottom of the pressure vessel is provided with a drain plug for shipping purposes. Provision for manual or automatic draining is necessary for proper operation.

CAUTION Do not attempt to remove drain plug if the unit is pressurized.

- A. Manual Drain - When draining is performed manually on a regular, periodic basis, a simple (open/shut) valve piped to the drain port may be used to drain the vessel. When draining manually, the valve should be opened slowly to avoid rapid depressurization and possible cartridge damage.
- B. Automatic Drain - Where regular manual draining is not performed, an automatic condensate drain should be used. A variety of drains are available from the manufacturer. Pipe automatic drains to the drain port.

An isolation valve is recommended if servicing drain is desired while the system is pressurized.

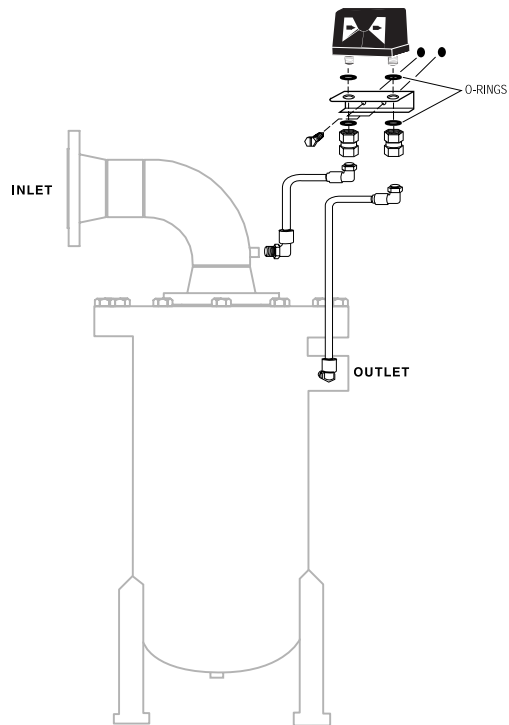

1.7 Differential pressure gauge

1. Maximum voltage switching 100 volts AC/DC
Maximum switching current 0.30 AMP
Maximum carrying current 1 AMP
Contact rating: 10 VA

A gauge and installation kit are shipped separately packaged for field installation. Gauge may be installed on vessel or on a nearby wall using the wall mounting bracket supplied.

NOTE: Make certain O-rings are in place on the bottom of the gauge body.

Connect the low pressure transmission bolt (bolt next to red band on gauge) to the gauge port at the filter outlet (downstream side of filter).

Connect the high pressure transmission bolt (bolt next to green band on gauge) to the gauge port at the filter inlet (upstream side of filter).

Torque bolts to 25 +/- 5 inch-oz. Do not over tighten.

1.8 Operating limitations

1. Maximum Working Pressure:
Standard ASME Coded Units 150 psig (10.3 bar)

NOTE: If using external drain, do not exceed pressure rating of drain.
2. Maximum Pressure Differential - 30 psi (2.1 bar)
IMPORTANT: Under normal circumstances the pressure differential across the filter should not exceed 30 psi (2.1 bar); excessive pressure drop may cause filter cartridge failure. Filter cartridge change-out recommended at 3 psi (0.2 bar).
3. Maximum Operating Temperature - 150°F (65°C)
NOTE: Temperatures above 120°F (49°C) are not recommended since filtration efficiency may decrease.
4. Chemical Resistance - Compressed air does not normally contain contaminants which will adversely affect the filter cartridge. However, some hydrocarbons, acids, bases and certain other chemicals can attack parts of the filter assembly. These contaminants are usually introduced through the compressor intake under certain environmental conditions.

Provision should be made to prevent this in order to protect the entire compressed air system. On questionable applications consult factory prior to installation.

2.0 OPERATION

2.1 After installation slowly pressurize Mist Eliminator and inspect for leaks. Operation is continuous and automatic.

2.2 Periodic checks are recommended to insure continuous separation and filtration efficiency.

A.. Check pressure drop

1. Check for excessive pressure drop. Pressure drop in excess of 3 psi (0.2 bar) indicates that the cartridge should be replaced.

IMPORTANT: Pressure drop should never exceed 30 psi (2.1 bar).

2. Check for sudden reduction in pressure drop. This might indicate a leak through the filter cartridge due to damage from chemical attack or excessive pressure drop.

B. Check the flow, pressure, and temperature to make sure that the filter is not being operated beyond its rated capacity. See Section 1.8 for operating Limitations and Section 2.3 to determine maximum flow capacity.

C. Check for proper drainage. See that manual drains are drained periodically and that automatic drains are functioning.

2.3 Determining maximum flow capacity

Maximum air flow for the various filters at 100 psig (7 bar) is indicated in Table 1. To determine maximum air flows at inlet pressures other than 100 psig (7 bar), multiply flow from Table 1 by multiplier from Table 2 that corresponds to the minimum operating pressure at the inlet of the filter.

2.4 Maximum Operating Conditions

Maximum Working Pressure: 150 psig (10.3 bar)

ASME coded pressure vessels

Maximum Operating Temperature: 150°F (65°C)

TABLE 1

Model Number	Flow scfm @ 100psig, 7bar
OME125	125
OME250	250
OME500	500
OME1100	1100
OME1500	1500
OME2100	2100
OME2400	2400
OME3000	3000

TABLE 2

Minimum Inlet Pressure psig/bar	Multiplier
20/1.4	0.30
30/2.1	0.39
40/2.8	0.48
60/4.1	0.65
80/5.5	0.82
100/7.0	1.00
120/8.3	1.17
150/10.3	1.43

3.0 MAINTENANCE

3.1 When to replace filter cartridge

- A. Initial (dry) pressure drop: 1 psi (0.07 bar) nominal.
- B. Operating pressure drop: During operation the filter cartridge becomes liquid loaded (wetted). At rated flow conditions, operating pressure drop will normally be: 0.5 to 1 psi (0.035 to 0.07 bar). Further pressure drop will occur only as the cartridge becomes loaded with solid particles.
- C. Changeout pressure drop: IT IS RECOMMENDED THAT THE CARTRIDGE BE REPLACED FOR MAXIMUM FILTRATION EFFICIENCY WHEN PRESSURE DROP REACHES 3 PSI (0.2 BAR).

NOTE: Pressure drop after flow interruption

When flow is interrupted for several hours, the pressure drop may temporarily increase upon the resumption of flow. Normally, within one hour, the pressure drop should return to where it was prior to stopping the flow. This phenomenon is not cause for filter cartridge replacement. It is due both to residual liquids contained within the cartridge "pooling" and a change in the viscosity of these liquids due to a temporary temperature change.

3.2. Procedure for filter cartridge replacement

THIS FILTER IS A PRESSURE CONTAINING DEVICE. DEPRESSURIZE BEFORE SERVICING.

- A. By-pass the filter assembly to permit servicing.
- B. Depressurize the filter assembly slowly by opening blowdown valve.
- C. Remove bolts securing the filter top to the vessel.
- D. Remove the top flange of the filter complete with filter element.
- E. Clean the inside of the vessel and inspect for any signs of corrosion.
- F. Unscrew the filter element from the top flange. Discard the element in accordance with applicable regulations.

Used elements typically hold contaminants, such as compressor lubricants and particulate matter.

- G. Thread new element into top flange.
- H. Replace top flange (complete with new filter element).
- I. Reinstall bolts to secure filter top.
- J. **Slowly** repressurize filter housing and check for any leaks.

DIMENSIONS AND WEIGHTS

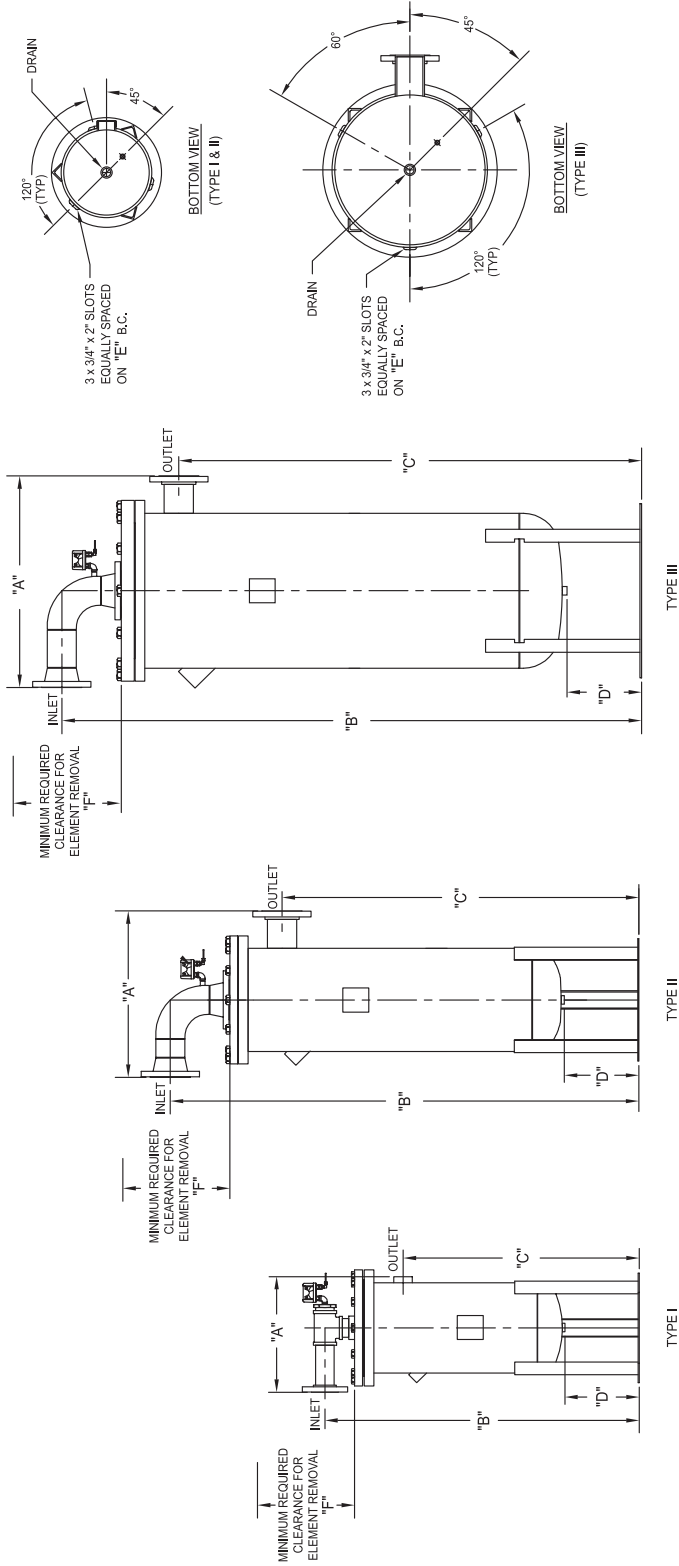

NOTES: Dimensions and Weights are for reference only. Request certified drawings for construction purposes.

Nominal Air Flow @ 100PSIG	125 SCFM	250 SCFM	500 SCFM	1100 SCFM	1500 SCFM	2100 SCFM	2400 SCFM	3000 SCFM
Vessel Type	Type I	Type I	Type I	Type II	Type II	Type II	Type II	Type III
Shell Size (O.D.)	14 (356)	14 (356)	14 (356)	16 (406)	18 (457)	24 (610)	24 (610)	24 (610)
Inlet Connection	2" FLG 150# CL	2" FLG 150# CL	2" FLG 150# CL	4" FLG 150# CL	4" FLG 150# CL	4" FLG 150# CL	4" FLG 150# CL	4" FLG 150# CL
Outlet Connection	2" NPT (F)	2" NPT (F)	2-1/2" NPT (F)	4" FLG 150# CL	4" FLG 150# CL	4" FLG 150# CL	4" FLG 150# CL	4" FLG 150# CL
"A"	17-3/4 (451)	17-3/4 (451)	17-15/16 (456)	25-13/16 (656)	26-13/16 (681)	32-13/16 (833)	32-13/16 (833)	32-13/16 (833)
"B"	37-1/8 (943)	37-1/8 (943)	48-1/16 (1221)	72-3/4 (1848)	80-1/8 (2035)	89-3/8 (2270)	89-3/8 (2270)	89-3/8 (2270)
"C"	27-1/8 (689)	27-1/8 (689)	36-1/2 (927)	55-1/8 (1400)	62-1/2 (1588)	71-1/2 (1816)	71-1/2 (1816)	71-1/2 (1816)
"D"	11-1/2 (292)	11-1/2 (292)	11-1/2 (292)	11-1/2 (292)	11-1/2 (292)	11-1/2 (292)	11-1/2 (292)	11-1/2 (292)
"E"	14 (356)	14 (356)	14 (356)	16 (406)	18 (457)	24 (610)	24 (610)	24 (610)
"F"	12 (305)	15 (381)	27 (686)	46 (1168)	46 (1168)	36 (914)	50 (1270)	62 (1574)
Filter Assembly Weight	185 (84)	185 (84)	220 (100)	350 (159)	390 (172)	700 (318)	715 (328)	730 (331)
Replacement Crtg Weight	15 (6.8)	20 (9)	35 (15.9)	60 (27.3)	80 (36.4)	120 (54.5)	135 (61.4)	150 (68.2)
Drain Size Connection	1" NPT	1" NPT	1" NPT	1" NPT	1" NPT	1" NPT	1" NPT	1" NPT
Replacement Cartridge	OME1	OME2	OME3	OME4	OME5	OME6	OME7	OME8

NOTES

- All models meet the requirements of the A.S.M.E. Boiler and Pressure Vessel Code and have the code stamp applied.
- Vessels with 4" nozzles have flanges only. The bolt holes straddle the vertical center line.
- Maximum operating temperature for all vessels is 150°F (66°C).

Mist Eliminator Warranty and Conditions of Sale

1. Mist Eliminator Coalescing Filter Cartridge 5 Year Guarantee Statement:

Seller guarantees that the coalescing filter cartridge shall not require replacement for five (5) years after shipment by Seller. This guarantee is based on the filter as delivered and is contingent upon the following:

- a) the filter is installed and operated as specified in the Installation and Operating Manual supplied with the filter and
- b) operation of the filter is within the filter specification limits.

2. Mist Eliminator 5 Year Warranty Statement:

Seller warrants that the filter will be free from defects due to materials or workmanship for five (5) years after shipment by Seller. If within thirty (30) days after Buyer's discovery of any such defects, Buyer notifies Seller thereof in writing, seller shall, at its options and as the exclusive remedy for this warranty, promptly repair or replace the portion of the filter found to be defective. Failure by Buyer to give Seller such written notice within the applicable time period specified above, shall be deemed a waiver of buyer's claim for such defects.

The warranty covers parts only for the warranty period. Products repaired or replaced under warranty shall be warranted for the unexpired portion of the warranty applying to the original product. This warranty is based on the filter as delivered and is contingent upon the following:

- a) the filter is installed and operated as specified in the Installation and Operating Manual supplied with the filter and
- b) operation of the filter is within the filter specification limits. The maximum damages liability of the manufacturer or seller is the original purchase price of the product or part.

The foregoing warranty is exclusive and in lieu of all warranties, whether written, oral, or statutory, and is expressed in lieu of the implied warranty of merchantability and the implied warranty of fitness for a particular purpose.

The manufacturer shall not be liable for loss or damage by reason of strict liability in tort or its negligence in whatever manner including design, manufacture or inspection of the equipment or its failure to discover, report, repair, or modify latent defects inherent therein.

The manufacturer, his representative or distributors shall not be liable for loss of use of the product or incidental or consequential costs, expense, or damages incurred by the buyer, whether arising from breach of warranty, negligence or strict liability in tort.

SERVICE DEPARTMENT : (724) 745-3038

KAESER

www.kaeser.com

KAESER COMPRESSORS

U.S.A. • P.O. Box 946 • Fredericksburg, VA 22404 • Tel: 540/898-5500 • Fax: 540/898-5520 • Service: (724) 745-3038

Canada • 3760 Rue La Verendrye • Boisbriand (Quebec) J7H 1R5 • Tel: 450/971-1414 • Fax: 450/971-1415 • Service: (724) 745-3038

KAESER COMPRESORES, S.A. de C.V.

Mexico • Calle 2, No. 111 Locales EYF • Parque Industrial Jurica • 76100 Querétaro, QRO Mexico • Tel: 52-42-18-64-48 • Fax: 52-42-18-64-49

KAESER KOMPRESSOREN

Austria • Ges.m.b.H. • A-4031 Linz, Dallingnerstr.8 • Telefon: (43) 732/38 60 51-0 • Fax: (43) 732/38 67 80 • Service: (43) 732/38 60 51-0

Singapore • 81 Tech Park Crescent • Tuas Tech Park • Singapore 638067 • Tel: (65) 68857733 • Fax: (65) 68857700 • 24-Hour Hotline: (65) 96838200