

Operator Manual

Rotary lobe blower

DBC vac SIGMA CONTROL 2

Number: 902312 03 USE

Manufacturer:

KAESER KOMPRESSOREN SE

96410 Coburg • PO Box 2143 • GERMANY • Tel. +49-(0)9561-6400 • Fax +49-(0)9561-640130

www.kaeser.com

Original instructions
/KKW/BBCV 2.14 en Z1 SBA-GEBLAESE-SC

20220708 084219

1	Regarding this Document	
1.1	Using this document	1
1.2	Further documents	1
1.3	Copyright	1
1.4	Symbols and labels	1
1.4.1	Warnings	1
1.4.2	Potential damage warnings	2
1.4.3	Other alert notes and their symbols	2
2	Technical Data	
2.1	Nameplate	4
2.2	Option codes	4
2.3	Weight	5
2.3.1	START CONTROL (STC)	5
2.3.2	OMEGA FREQUENCY CONTROL (OFC)	6
2.4	Drive motor	6
2.5	Recommended oil	6
2.6	Lubricating oil charge	7
2.7	Permitted pressure drop	7
2.8	Temperature	7
2.9	Ambient and intake conditions	7
2.10	Sound pressure level	8
2.11	Power Supply	8
2.12	Power supply specifications	9
2.12.1	START CONTROL (STC)	9
2.12.2	OMEGA FREQUENCY CONTROL (OFC)	10
2.13	Options	11
2.13.1	Oil level monitoring	11
2.13.2	Speed monitor	11
2.13.3	Check valve	12
2.13.4	Piped inlet	12
2.13.5	Fan (sound enclosure)	12
2.13.6	Exhaust silencer (pipeline)	12
2.13.7	Exhaust silencer (diffusion to ambient)	13
3	Safety and Responsibility	
3.1	Basic instructions	14
3.2	Specified use	14
3.3	Improper use	14
3.4	User's responsibilities	15
3.4.1	Observe statutory and universally accepted regulations	15
3.4.2	Qualified personnel	15
3.5	Dangers	15
3.5.1	Safely dealing with sources of danger	15
3.5.2	Safe machine operation	17
3.5.3	Organizational measures	19
3.6	Danger areas	20
3.7	Safety devices	20
3.8	Working life of safety functions	20
3.9	Safety signs	21
3.10	In emergency	23
3.10.1	Correct fire fighting	23
3.10.2	Remove lubricating oil from the skin.	24
3.11	Environmental protection	24
3.12	Warranty	24

4	Design and Function	
4.1	Enclosure	25
4.2	SIGMA CONTROL 2 operating panel	26
4.2.1	Keys	26
4.2.2	LEDs	27
4.2.3	RFID sensor field	27
4.3	Machine	28
4.4	Blower block	29
4.5	Safety relief valve	29
4.6	Safety devices	30
4.7	Compensator	30
4.8	Automatic starting	30
4.9	Floating relay contacts	31
4.10	Options	31
4.10.1	Oil level monitor	31
4.10.2	Speed monitor	31
4.10.3	Check valve	31
4.10.4	Piped inlet	31
4.10.5	Exhaust silencer (pipeline)	31
4.10.6	Exhaust silencer (diffusion to surroundings)	32
5	Installation and Operating Conditions	
5.1	Ensuring safety	34
5.2	Installation conditions	34
5.2.1	Determining installation location and clearances	34
5.2.2	Ensuring adequate ventilation	36
6	Installation	
6.1	Ensuring safety	37
6.2	Reporting transport damage	38
6.3	Anchoring the machine	38
6.4	Connecting the power supply	38
6.4.1	Under frequency control	39
6.5	Connecting to the vacuum network	39
6.6	Sound enclosure: Removing transport securing devices	40
6.7	Fitting the cover plate	40
7	Initial Start-up	
7.1	Ensuring safety	42
7.2	Instructions to be observed before commissioning	43
7.3	Checking installation and operating conditions	43
7.4	Re-greasing the motor bearings	44
7.5	Configuring the controller	44
7.6	Setting the display language	44
7.7	Checking the direction of rotation for the drive motor	45
7.8	START CONTROL (STC): Setting the overload protection cut-out	46
7.9	Starting the machine for the first time	46
8	Operation	
8.1	Switching on and off	47
8.1.1	Switching on	47
8.1.2	Switching off	48
8.2	Switching off in an emergency and switching on again	48
8.3	Switching on and off from a remote control center	49
8.4	Switching on and off with the clock (timer)	50
8.5	Checking the ventilator fan function (sound enclosure)	51

8.6	Interpreting operation messages	51
8.7	Acknowledging alarm and warning messages	51
9	Fault Recognition and Rectification	
9.1	Basic instructions	53
9.2	Other faults	53
9.3	Sound enclosure faults	54
10	Maintenance	
10.1	Ensuring safety	55
10.2	Maintenance schedule	56
10.2.1	Logging maintenance work	56
10.2.2	Resetting maintenance interval counters	56
10.2.3	Regular maintenance tasks	56
10.2.4	Regular service tasks	57
10.3	Control cabinet: Clean or replace the filter mats	58
10.4	Sound enclosure	59
10.5	Drive belt maintenance	60
10.6	Checking the oil level	61
10.7	Replenishing lubricating oil	61
10.8	Changing the oil	62
10.9	Air filter maintenance	63
10.10	Air filter maintenance	64
10.11	Machine cleaning	65
10.12	Motor maintenance	65
10.12.1	Drive motor bearings with re-greasing facility	65
10.12.2	Permanently greased drive motor bearings	66
10.12.3	Fan motor	66
10.13	Testing the safety relief valve	66
10.14	Testing the EMERGENCY STOP push button	67
10.15	Documenting maintenance and service work	68
11	Spares, Operating Materials, Service	
11.1	Note the nameplate	69
11.2	Ordering spares and operating fluids/materials	69
11.3	Replacement parts for service and repair	69
11.3.1	Option C33, START CONTROL (STC)	69
11.3.2	Option C34, OMEGA FREQUENCY CONTROL (OFC)	72
11.4	KAESER AIR SERVICE	75
11.5	Completing the contamination declaration	75
12	Decommissioning, Storage and Transport	
12.1	Decommissioning	76
12.2	Packing	76
12.3	Transport	77
12.3.1	Safety	77
12.3.2	Transport machine with a pallet truck or forklift truck	77
12.4	Storage	77
12.5	Disposal	78
13	Annex	
13.1	Pipeline and instrument flow diagram (P+I diagram)	79
13.2	Dimensional drawing	82
13.3	Sound emission	85
13.4	Electrical diagrams	88
13.4.1	Option C33, START CONTROL (STC)	88
13.4.2	Option C34, OMEGA FREQUENCY CONTROL (OFC)	139

13.5 Project planning data 176

Fig. 1	Three-phase star (wye); 4 wire; center point solidly grounded	9
Fig. 2	Three-phase star (wye); 3 wire; center point solidly grounded	9
Fig. 3	Location of the safety signs on the machine	21
Fig. 4	Safety sign location, electronically actuated components	21
Fig. 5	Safety sign position, blow-off silencer, Option H16, H19	21
Fig. 6	Enclosure	25
Fig. 7	Indicating and operating elements	26
Fig. 8	Indicating and operating elements	27
Fig. 9	RFID sensor field	28
Fig. 10	Machine	28
Fig. 11	Blower block	29
Fig. 12	Safety relief valve	29
Fig. 13	Compensator	30
Fig. 14	Exhaust silencer (pipeline)	32
Fig. 15	Exhaust silencer (diffusion to surroundings)	33
Fig. 16	Recommended positioning of the machine, minimum dimensions [in.]	35
Fig. 17	Removing the transport securing devices	40
Fig. 18	Fitting the cover plate	41
Fig. 19	Switching on and off	47
Fig. 20	Switching off in an emergency	48
Fig. 21	Switching on and off from a remote control center	49
Fig. 22	Switching on and off with the clock (timer)	50
Fig. 23	Acknowledging messages	52
Fig. 24	Control cabinet ventilation	59
Fig. 25	Sound enclosure	59
Fig. 26	Drive belt maintenance	60
Fig. 27	Checking the oil level	61
Fig. 28	Replenishing lubricating oil	62
Fig. 29	Changing the oil	63
Fig. 30	Changing the air filter	64
Fig. 31	Drive motor maintenance	66
Fig. 32	Testing the EMERGENCY STOP push button	67
Fig. 33	Transport	77

Tab. 1	Danger levels and their definition (personal injury)	1
Tab. 2	Danger levels and their definition (damage to property)	2
Tab. 3	Nameplate	4
Tab. 4	Option codes	4
Tab. 5	START CONTROL (STC) weight	5
Tab. 6	Weight OMEGA FREQUENCY CONTROL (OFC)	6
Tab. 7	Drive motor	6
Tab. 8	Recommended oil	6
Tab. 9	Lubricating oil charge	7
Tab. 10	Temperature	7
Tab. 11	Ambient and intake conditions	8
Tab. 12	Connection data 208V±10% / 3 / 60Hz	9
Tab. 13	Connection data 230V±10% / 3 / 60Hz	10
Tab. 14	Connection data 460V±10% / 3 / 60Hz	10
Tab. 15	Connection data 575V±10% / 3 / 60Hz	10
Tab. 16	Connection data 460V/ 3 / 60Hz	11
Tab. 17	Oil level monitoring (Option C5)	11
Tab. 18	Speed monitor (Option C10)	11
Tab. 19	Speed monitor sensor (Option C10)	12
Tab. 20	Check valve (Option G1)	12
Tab. 21	Fan flow rate	12
Tab. 22	Danger areas	20
Tab. 23	Category and Performance Level	20
Tab. 24	Safety signs	21
Tab. 25	Controls	26
Tab. 26	Display elements	27
Tab. 27	RFID sensor field	28
Tab. 28	Recommended positioning of the machine, minimum dimensions	35
Tab. 29	Compensator torques	40
Tab. 30	Recommissioning after storage/standstill	43
Tab. 31	Installation conditions check list	43
Tab. 32	Starting frequency	47
Tab. 33	Machine identification	49
Tab. 34	Remote control identification	49
Tab. 35	Machine identification	50
Tab. 36	Other faults and remedies	53
Tab. 37	Faults and remedies (option H12)	54
Tab. 38	Regular maintenance tasks	57
Tab. 39	Regular service tasks	58
Tab. 40	Logged maintenance tasks	68
Tab. 41	Consumable parts	69
Tab. 42	Sound emission - legend	85

1 Regarding this Document

1.1 Using this document

This operating or installation manual is part of the machine. It describes the machine as it was at the time of first delivery after manufacture.

- Keep the operating manual in a safe place throughout the life of the machine.
- Pass the operating manual on to the next owner/user.
- Ensure that all amendments received are entered or inserted in the operating manual.
- Enter details from the machine nameplate and individual items of equipment in the tables in chapter 2.

1.2 Further documents

Included with this Operating Manual are additional documents intended to assist in the safe operation of the machine:

- Manufacturer's Declaration or Declaration of Conformity according to applicable directives.
- User Manual for SIGMA CONTROL 2.

Missing documents can be requested from KAESER.

- Ensure that all documents are complete and observe the instructions contained within them.
- Ensure that you provide the data from the nameplate when ordering documents.

1.3 Copyright

This operator manual is copyright protected. Queries regarding use or duplication of the documentation should be referred to KAESER. Correct use of information will be fully supported.

1.4 Symbols and labels

- Please note the symbols and labels used in this document.

1.4.1 Warnings

Warnings indicate danger potentially resulting in personal injury, if the measures specified are not taken.

Warnings indicate three levels of danger identified by the corresponding signal word:

Signal term	Meaning	Consequences of non-compliance
DANGER	Warns of imminent danger	Will very likely result in death or severe injury
WARNING	Warns of potentially imminent danger	May result in death or severe injury
CAUTION	Warns of a potentially dangerous situation	May result in moderate physical injury

Tab. 1 Danger levels and their definition (personal injury)

Warning notes may precede a chapter. They apply to the entire chapter including all sub-sections.

1 Regarding this Document

1.4 Symbols and labels

Example:

⚠ DANGER

The type and source of the imminent danger is shown here!

The possible consequences of ignoring a warning are shown here.

The word "DANGER" indicates that death or severe injury can very likely result from ignoring the warning.

➤ *The measures required to protect yourself from danger are shown here.*

Warning notes referring to a sub-section or the subsequent step are integrated into the procedure and numbered as a step.

Example:

1. **⚠ WARNING** *The type and source of the imminent danger is shown here!*
The possible consequences of ignoring a warning are shown here.
The word "WARNING" indicates that death or severe injury may result from ignoring the warning.
➤ *The measures required to protect yourself from danger are shown here.*
2. Always read and comply with warning instructions.

1.4.2 Potential damage warnings

Contrary to the warnings shown above, damage warnings do not indicate potential personal injury.

Damage warnings have only one danger level, identified by this signal word:

Signal term	Meaning	Consequences of non-compliance
NOTE	Warns of a potentially dangerous situation	Damage to property is possible

Tab. 2 Danger levels and their definition (damage to property)

Example:

NOTICE

The type and source of the imminent danger is shown here!

Potential effects when ignoring the warning are indicated here.

➤ *The protective measures against the damages are shown here.*

➤ Carefully read and fully comply with warnings against damages.

1.4.3 Other alert notes and their symbols



This symbol indicates particular important information.

Material Here you will find details on special tools, operating materials or spare parts.

Precondition Here you will find conditional requirements necessary to carry out the task.
The conditional requirements relevant to safety shown here will help you to avoid dangerous situations.

Option H12 ➤ This symbol is placed by lists of actions comprising one stage of a task.
Operating instructions with several steps are numbered in the sequence of the operating steps.
Information relating to one option only are marked with an option code (e.g., H12 indicates that this section applies only to machines with sound enclosure). Option codes used in this operating manual are explained in chapter 2.2.



Information referring to potential problems are identified by a question mark.
The cause is specified in the help text ...
➤ ... as is a solution.



This symbol refers to important information or measures concerning environmental protection.

Further information Further subjects are introduced here.

2 Technical Data

2.1 Nameplate

The machine's nameplate contains the model type and important technical information.

The nameplate is attached to the machine frame and on the left-hand side panel of the sound enclosure (Option H12).

The specified value for the full load current has been calculated including the associated lambda factor. This value can be found in chapter 2.12.2 (Option C34).

The information given on the nameplate relates to the standard inlet conditions of 14.7 psi and +68°F.

➤ Enter the data from the nameplate here as a reference:

Characteristic	Value
Rotary lobe blowers	
Material no.	
Serial no.	
Ambient temperature	
Rated power	
Rated motor speed	
Full load current	
Full load current, drive motor	
Electrical connection	
Wiring diagram	
Year of manufacture	

Tab. 3 Nameplate

2.2 Option codes

The table contains a list of possible options.

➤ Enter options here as a reference:

Option	Option code	Available?
Operating mode: Vacuum	B14	✓
Oil level monitoring	C5	
Speed monitor	C10	
Unloaded start valve (AFE)	C11	—
Unloaded start valve with regulating valve (AFR)	C18	—
Under frequency control	C32	
START CONTROL (STC)	C33	
OMEGA FREQUENCY CONTROL (OFC)	C34	

Available: ✓

Not available: —

Option	Option code	Available?
Oil temperature monitoring	C39	—
Communication module: PROFIBUS DP	C41	
Communication module: Modbus RTU	C42	
Communication module: DEVICENET	C43	
Communication module: Modbus TCP	C44	
Communication module: PROFINET IO	C45	
Filter differential pressure switch	F5	
Check valve	G1	
Intake from pipe network	H11	✓
Sound enclosure	H12	✓
Exhaust silencer (pipeline)	H16	
Exhaust silencer (diffusion to surroundings)	H19	
Available: ✓		
Not available: —		

Tab. 4 Option codes

2.3 Weight

The values shown are maximum values. The actual weight of individual machines depends on equipment fitted.

2.3.1 Option C33 START CONTROL (STC)

Rated power [hp]	Weight [lb]		—
	DB 166 C vac	DB 236 C vac	
7.5	543	—	—
10.0	557	—	—
15.0	559	579	—
20.0	589	609	—
25.0	599	619	—
30.0	622	642	—
40.0	680	700	—
50.0	705	725	—
60.0	—	755	—

Tab. 5 START CONTROL (STC) weight

2.3.2 Option C34
OMEGA FREQUENCY CONTROL (OFC)

Rated power [hp]	Weight [lb]		—
	DB 166 C vac	DB 236 C vac	
7.5	573	—	—
10.0	587	—	—
15.0	594	614	—
20.0	624	644	—
25.0	644	664	—
30.0	677	697	—
40.0	735	755	—
50.0	765	785	—
60.0	—	—	—

Tab. 6 Weight OMEGA FREQUENCY CONTROL (OFC)

2.4 Drive motor

➤ Copy the data from the motor nameplate or service plate into the table:

Feature	Value
Enclosure protection	IP55
Motor bearing re-greasing interval *[h]	2000
Grease requirement, each bearing [g]	

h = operating hours

* The lubricating interval is max. 2000 h, even if a longer interval is indicated on the motor service plate.

Tab. 7 Drive motor

2.5 Recommended oil

The lubricant type to be used depends on the operating conditions.

	OMEGA FLUID	
	SB 220	FGB 220
Description	Synthetic oil	Synthetic oil

	OMEGA FLUID	
	SB 220	FGB 220
Application	Suitable for all applications, except food processing.	Specifically for applications where the compressed air comes into contact with food products.

Tab. 8 Recommended oil

Further information An adhesive label identifying the used lubricating oil is attached to the blower block and the belt guard.

Information on ordering oil is found in chapter 11.2.

2.6 Lubricating oil charge

The block oil chambers are filled with oil at the factory.

Guide value

	Drive-end	Gear-end
Lubricating oil charge [qt]	0.26 ±15%	0.32 ±15%

Tab. 9 Lubricating oil charge

2.7 Permitted pressure drop

Ensure that the pressure drop in the downstream pipes is max. 0.2 psi.



The same applies to machines with exhaust silencer (pipe), option H16.

2.8 Temperature

	DB 166 C vac	DB 236 C vac	—
Maximum block discharge temperature [°F]	320	320	—
Maximum temperature differential [K] *	115	115	—

*Discharge temperature minus inlet temperature

Tab. 10 Temperature

2.9 Ambient and intake conditions

The following conditions must be maintained:

- No salty atmosphere in the immediate vicinity of the machine.
- The air must be free of chemicals or explosive substances.

	DB 166 C vac	DB 236 C vac	—
Permissible ambient temperature [°F]	32 – 104	32 – 104	—
Permissible intake temperature [°F]	14 – 104	14 – 104	—
Relative humidity [%]	0 – 80	0 – 80	—
Maximum altitude AMSL [ft.]	3281	3281	—

Tab. 11 Ambient and intake conditions



Differing ambient and intake conditions require the recalculation of the performance data, and are permissible only upon agreement by the manufacturer.

2.10 Sound pressure level

Operating state LOAD under the following conditions:

- Nominal speed
- Nominal suction capacity
- Nominal pressure

Measuring condition according to DIN EN ISO 2151 and basic standard ISO 9614–2:

- Measurement distance: 3 ft.
- Tolerance: ± 3 dB(A)
- Sound insulated pipeline

Further information The sound pressure level and sound power level values for your machine are provided in the tables shown in chapter 13.3.

These values refer to the design condition. They do not apply to the control range with frequency converter.

2.11 Power Supply

Basic requirements

The machine is designed for an electrical supply according to National Electric Code (NEC), edition 2020, particularly article 670 and NFPA 79, edition 2021, particularly section 4.4. In the absence of any user-specified alternatives, the limits given in these standards must be adhered to. Consult manufacturer for any other specific power supply.

The incoming line within the control panel should be as short as possible.

If external sensors or communication lines are to be connected to the machine, use shielded cables and insert the same through EMC fittings into the control panel.

Three-phase

Do **NOT** operate package on any unsymmetrical power supply. Also do **NOT** operate package on power supplies such as a three phase WYE system with center point not solidly grounded or three-phase (open) delta.

The machine requires a symmetrical three-phase power supply transformer with a WYE configuration output as shown in Figure 1 and Figure 2. In a symmetrical three phase supply the phase angles and voltages are all the same.

Other power supplies are not suitable.



Fig. 1 Three-phase star (wye); 4 wire; center point solidly grounded

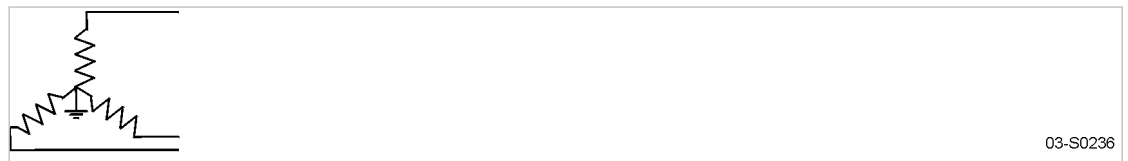

Fig. 2 Three-phase star (wye); 3 wire; center point solidly grounded

Further information Please contact an authorized KAESER service representative for options.
The electrical diagram 13.4 contains further specifications for electrical connection.

2.12 Power supply specifications

The following multi-strand copper core wires are given according to 2020 NEC 310.14, 310.15, 310.16 and table 310.16 adjusted for 40°C ambient temperature.

If other local conditions prevail, like for example high temperature, the cross section should be checked and adjusted according to 2020 NEC 110.14(C), 220.3, 310.14, 310.15, 310.16, 310.15(B)(1), table 310.15(C)(1), 430.6, 430.22, 430.24, 670.4(A) and other local codes.

Dual element time delay fuses are selected according to 2020 NEC 240.6, 430.52 and tables 430.52, 430.248 and 430.250.

We strongly suggest using a separate copper conductor for the equipment GROUNDING. 2020 NEC table 250.122 will point out the “minimum size”, however, we recommend a ground conductor the same size as the power leads, if local codes allow.

2.12.1 Option C33 START CONTROL (STC)

Rated power supply: 208V±10% / 3 / 60Hz

Rated power [hp]	7.5	10.0	15.0	20.0	25.0	30.0	40.0	50.0	60.0
Backup fuse [A]	25.0	35.0	45.0	70.0	70.0	90.0	125.0	125.0	—
Supply line [AWG]	1x 4x10	1x 4x8	1x 4x6	1x 4x4	1x 4x3	1x 4x2	1x 4x1/0	1x 4x1/0	—
Current consumption [A]	21.6	28.2	40.2	55.0	63.2	75.2	101.2	105.2	—

Tab. 12 Connection data 208V±10% / 3 / 60Hz

Rated power supply: 230V±10% / 3 / 60Hz

Rated power [hp]	7.5	10.0	15.0	20.0	25.0	30.0	40.0	50.0	60.0
Backup fuse [A]	25.0	35.0	50.0	70.0	80.0	90.0	125.0	125.0	—
Supply line [AWG]	1x 4x10	1x 4x8	1x 4x6	1x 4x4	1x 4x3	1x 4x2	1x 4x1/0	1x 4x1/0	—
Current consumption [A]	22.3	28.9	42.3	56.9	66.9	78.1	104.9	106.9	—

Tab. 13 Connection data 230V±10% / 3 / 60Hz

Rated power supply: 460V±10% / 3 / 60Hz

Rated power [hp]	7.5	10.0	15.0	20.0	25.0	30.0	40.0	50.0	60.0
Backup fuse [A]	15.0	20.0	25.0	35.0	40.0	45.0	60.0	60.0	—
Supply line [AWG]	1x 4x14	1x 4x12	1x 4x10	1x 4x8	1x 4x8	1x 4x6	1x 4x4	1x 4x4	—
Current consumption [A]	11.2	14.5	21.2	28.4	33.5	39.1	52.5	53.5	—

Tab. 14 Connection data 460V±10% / 3 / 60Hz

Rated power supply: 575V±10% / 3 / 60Hz

Rated power [hp]	7.5	10.0	15.0	20.0	25.0	30.0	40.0	50.0	60.0
Backup fuse [A]	10.0	12.0	20.0	25.0	30.0	35.0	50.0	50.0	—
Supply line [AWG]	1x 4x14	1x 4x14	1x 4x12	1x 4x10	1x 4x10	1x 4x8	1x 4x6	1x 4x6	—
Current consumption [A]	8.2	10.4	15.3	20.4	23.6	28.0	42.2	42.7	—

Tab. 15 Connection data 575V±10% / 3 / 60Hz

**2.12.2 Option C34
 OMEGA FREQUENCY CONTROL (OFC)**
Protective conductor requirements

Due to the leakage currents of ≥ 10 mA caused by the anti-interference capacitors in the frequency converter, a minimum diameter of 8 AWG is required for the protective conductor.

Use one of the following options if the protective conductor for the supply cable is smaller than 8 AWG:

- Multicore cable including protective conductor with a minimum cross-section of 8 AWG,
- a minimum cross-section of 8 AWG for the protective conductor alone,
- a second protective conductor with the same cross-section as the supply line,
- automatic deactivation of the power supply as soon as the protective conductor is interrupted.



Note on the lambda factor:

In addition to their fundamental oscillation, non-sinusoidal variables also contain harmonics for which no fixed phase shift angle ϕ (phi) can be specified. Instead, the power factor λ (lambda) must be used. In electrical engineering, the power factor λ denotes the ratio of the active power value P to the apparent power value S.

In the event of deviating network characteristics and therefore lambda value at the user-end, the full load current and supply cable cross-section may need to be reassessed.

Rated power supply: 460V / 3 / 60Hz

Rated power [hp]	7.5	10.0	15.0	20.0	25.0	30.0	40.0	50.0	60.0
Backup fuse [A]	15.0	20.0	30.0	35.0	40.0	45.0	60.0	70.0	90.0
Supply line [AWG]	1x 4x8	1x 4x8	1x 4x8	1x 4x8	1x 4x8	1x 4x6	1x 4x4	1x 4x2	1x 4x2
Current consumption [A]	13.4	17.4	23.6	29.8	33.2	39.2	50.7	60.9	74.3
Power factor [λ] (lambda)	0.730	0.736	0.769	0.820	0.900	0.900	0.900	0.917	0.920

Tab. 16 Connection data 460V/ 3 / 60Hz

2.13 Options

Technical data for the options available for your machine are given in the following.

2.13.1 Option C5 Oil level monitoring

Feature	Data
Max. voltage [V]	48
Switching current [A]	0.5
Switching capacity [hp]	0.03
Type of contact	Normally closed
Degree of protection	IP67

Tab. 17 Oil level monitoring (Option C5)

Further information The electrical diagram in chapter 13.4 contains details of the power supply.

2.13.2 Option C10 Speed monitor

Sensor

Feature	Data
Rated switching distance S_n [in.]	0.12–0.16
Installation conditions	Not flush
Output function	DC PNP/NPN
Enclosure protection	IP 67

Feature	Data
Connection	M12
Working principle	Inductive

Tab. 18 Speed monitor (Option C10)

Sensor

Feature	Data
Rated voltage [V]	110 – 240 AC/DC (50 – 60 Hz) / 27 DC (typ. 24 DC)
Contact load capacity	6 A (250 V AC); B300, R300
Power consumption [VA]	5
Start override [s]	0 – 1000
Ambient temperature [°F]	-4 – +140
Degree of protection - enclosure/terminals	IP 50 / IP 20
Connection	up to 2.5 mm ² (AWG 14)

Tab. 19 Speed monitor sensor (Option C10)

Further information The electrical diagram in chapter 13.4 contains details of the power supply.

**2.13.3 Option G1
Check valve**

Nominal pipe size	Max. pressure and back pressure [psi]
DN 100	21.8
—	—

Tab. 20 Check valve (Option G1)

**2.13.4 Option H11
Piped inlet**

The dimensional drawings in chapter 13.2 include connection dimensions.

**2.13.5 Option H12
Fan (sound enclosure)**

Feature	Value
Maximum flow rate [cfm]	1177

Tab. 21 Fan flow rate

**2.13.6 Option H16, H12
Exhaust silencer (pipeline)**

The mounting position is shown in the dimensional drawing in chapter 13.2.

2.13.7 Option H19, H12
Exhaust silencer (diffusion to ambient)

The mounting position is shown in the dimensional drawing in chapter 13.2.

3 Safety and Responsibility

3.1 Basic instructions

The machine is manufactured to the latest engineering standards and acknowledged safety regulations. Nevertheless, dangers can arise through its operation:

- Danger to life and limb of the operator or third parties,
- Damages to the machine and other material assets.



Disregard of warning or safety instructions can cause serious injuries!

- Read the operating and installation manual carefully and take note of the contents for safe machine operation.
- Use this machine only if it is in a technically perfect condition and only for the purpose for which it is intended; observe all safety measures and the instructions in the service manual!
- Immediately rectify (have rectified) any faults that could be detrimental to safety!

3.2 Specified use

The machine is designed exclusively for the generation of vacuum in a commercial or industrial environment where air as delivery medium is approved for use. Any other use is considered incorrect. The manufacturer is not liable for any damages that may result from incorrect use. The user alone is liable for any risks incurred.

- Comply with the instructions in this operating manual.
- Operate the machine only within its performance limits and under the permitted ambient conditions.
- Operate the machine only when completely installed.

3.3 Improper use

Improper usage can cause damage to property and/or (severe) injuries.

- Only use the machine as intended.
- Use hot cooling air for heating purposes only if there is no risk to the health of humans or animals. If necessary, cooling air should be treated by suitable means.
- Do not allow the machine to take in toxic, acidic, flammable or explosive gases or vapors.
- Do not operate the machine in areas in which specific requirements with regard to explosion protection are in force.
- Intake of solid particles > 0.004 inch is not permitted.
- Persons are not allowed to remain near the exhaust outlet.
- Exhaust air must not be used for breathing purposes.

3.4 User's responsibilities

3.4.1 Observe statutory and universally accepted regulations

This is, for example, nationally implemented European directives and/or applicable national legislation, safety and accident prevention regulations.

- Observe relevant statutory and accepted regulations during installation, operation and maintenance of the machine.

3.4.2 Qualified personnel

These are people who, by virtue of their training, knowledge and experience as well as their knowledge of relevant regulations can assess the work to be done and recognize the possible dangers involved.

Authorized operators possess the following qualifications:

- Are of legal age,
- Are familiar with and adhere to the safety instructions and sections of the service manual relevant to operation,
- Have received adequate training and authorization to operate electrical and vacuum devices.

Authorized installation and maintenance personnel have the following qualifications:

- Are of legal age,
 - Have read, are familiar with and adhere to the safety instructions and sections of the service manual applicable to installation and maintenance,
 - Are completely familiar with the safety concepts and regulations of electrical and vacuum engineering,
 - Are able to recognize the possible dangers of electrical and vacuum devices and take appropriate measures to safeguard persons and property,
 - Have received adequate training in and authorization for the safe installation and maintenance of this machine.
- Ensure that personnel entrusted with operation, installation and maintenance are qualified and authorized to carry out their tasks.

3.5 Dangers

Basic instructions

Information concerning the various forms of danger that can arise during machine operation are found here.

Basic safety instructions are found in this service manual at the beginning of each chapter in the section entitled 'Safety'.

Warning instructions are found before a potentially dangerous task.

3.5.1 Safely dealing with sources of danger

The following describes the various forms of danger that can occur during machine operation.

Electricity

Touching voltage carrying components can result in electric shocks, burns or death.

- All power supplies must be fitted with lockable isolating devices by the user.
- Allow only qualified and authorized electricians or trained personnel under the supervision of a qualified and authorized electrician to carry out work on electrical equipment according to electrical engineering regulations.
- Before commissioning or re-commissioning the machine, the user must ensure adequate protection against electric shock from direct or indirect contact.
- Before starting any work on electrical equipment:
Switch off and lock out the power supply disconnecting device, and verify the absence of any voltage.
- Switch off any external power sources.
These may be connections to the electric machine heating for example.
- Use fuses corresponding to machine power.
- Regularly check that all electrical connections are tight and in proper condition.

Forces of compression

- Do not carry out welding, heat treatment or mechanical modifications on pressurized components, as this adversely affects the components' resistance to pressure.
The safety of the machine cannot be guaranteed.

Quality of discharge air

The quality of the discharge air and any substances it may contain depends on the quality of the air drawn from the vacuum network.

- Never breathe in exhaust air.
- Lead exhaust air outdoors to a point far from any persons.

Spring forces

Springs under tension or compression store energy. Uncontrolled release of this energy can cause serious injury or death.

Safety relief valves are heavily spring-loaded.

- Do not open or dismantle any valves.

Rotating components

Touching the fan wheel or the belt drive while the machine is running can result in serious injury.

- Do not remove separating protective installations when the machine is running.
- Switch off and lock out the power supply disconnecting device, and verify the absence of any voltage.
- Wear close-fitting clothes and a hair net if necessary.
- Ensure that all covers and safety guards are in place and secured before re-starting.

Temperature

High temperatures are generated during compression. Touching hot components may cause injuries.

- Switch off and lock out the power supply disconnecting device and verify the absence of any voltage.
- Wear close-fitting clothes and a hair net if necessary.
- Ensure that all covers and safety guards are in place and secured before re-starting.

Noise

The sound enclosure absorbs the machine noise to a tolerable level. This function will be effective only if the sound enclosure is closed.

- Wear hearing protection if necessary.

Operating fluids/materials

The used operating fluids and materials can cause adverse health effects. Suitable safety measures must be taken in order to prevent injuries.

- Strictly forbid fire, open flame and smoking.
- Follow safety regulations when dealing with oils, lubricants, and chemical substances.
- Avoid contact with skin and eyes.
- Do not inhale oil mist and vapors.
- Do not eat or drink while handling lubricants.
- Keep suitable fire extinguishing agents ready for use.
- Use only KAESER approved operating materials.

Unsuitable spare parts

Unsuitable spare parts compromise the safety of the machine.

- Use only spare parts approved by the manufacturer for use in this machine.
- Use only genuine KAESER replacement parts on pressure bearing parts.

Conversion or modification of the machine

Modifications, additions or conversions to or of the machine can result in unpredictable hazards.

- Do not convert or modify the machine!
- Prior to any technical modification and expansions of the machine, obtain the written approval of the manufacturer.

Extending or modifying the compressor station

If dimensioned appropriately, safety relief valves reliably prevent an impermissible rise in pressure. New dangers may arise if you modify or extend the compressor station.

- When extending or modifying the compressor system:
Check the blow-off capacity of the safety relief valves prior to installing the new machine.
- If the blow-off capacity is insufficient:
Install safety relief valves with larger blow-off capacity.

3.5.2 Safe machine operation

The following is information supporting you in the safe handling of the machine during individual product life phases.

Personal protective equipment

When working on the machine you may be exposed to dangers that can result in accidents with severe adverse health effects.

- Wear protective clothing as necessary.

Suitable protective clothing (examples):

- Safety work wear
- Protective gloves
- Safety boots
- Eye protection
- Ear protection

Transporting

The weight and size of the machine require safety measures during its transport to prevent accidents.

- Use suitable lifting gear that conforms to local safety regulations.
- Allow transportation only by personnel trained in the safe movement of loads.
- Attach lifting gear only to suitable lifting points.
- Be aware of the center of gravity to avoid tipping.
- Make sure the danger zone is clear of personnel.
- Do not step onto machine components to climb up the machine.

Assembly

- Make sure no power is applied when electrical connections are made.
- Use only electrical cables that are suitable and approved for the surroundings and electrical loads applied.
- Attach or detach pipework only with the machine at atmospheric pressure.
- Use only pressure lines that are suitable and approved for the maximum working vacuum and the intended medium.
- Do not allow connection pipes to be placed under mechanical stress.
- Do not induce any forces into the machine via the connections, so that the compressive forces must be balanced by bracing.
- Do not step onto machine components to climb up the machine.

Installation

A suitable installation location for the machine prevents accidents and faults.

- Install the machine in a suitable compressor room.
- Ensure sufficient and suitable lighting such that the display can be read and work carried out comfortably and safely.
- Ensure accessibility so that all work on the machine can be carried out without danger or hindrance.
- If installed outdoors, the machine must be protected from frost, direct sunlight, dust, rain and splashing water.
- Do not operate in areas in which specific requirements with regard to explosion protection are in force.

- Ensure adequate ventilation.
- Place the machine in such a manner that the working conditions in its environment are not impaired.
- Comply with limit values for ambient temperature and humidity.
- The intake air must not contain any damaging contaminants, Damaging contaminants are for instance: explosive or chemically instable gases and vapors, acid or base forming substances such as ammonia, chlorine or hydrogen sulfide.
- Do not position the machine in the warm exhaust air flow from other machines.
- Keep suitable fire extinguishing agents ready for use.

Commissioning, operation and maintenance

During commissioning, operation and maintenance you may be exposed to dangers resulting from, e.g., electricity, pressure and temperature. Careless actions can cause accidents with severe adverse effects for your health.

- Allow maintenance work to be carried out only by authorized personnel.
- Wear close-fitting, flame-resistant clothing. Wear protective clothing as necessary.
- Switch off and lock out the power supply disconnecting device, and verify the absence of voltage.
- Check that there is no voltage on floating relay contacts.
- Vent all components and chambers under vacuum to atmospheric pressure.
- Allow the machine to cool down.
- Do not open the sound enclosure while the machine is switched on.
- Do not open or dismantle any valves.
- Use only spare parts approved by KAESER for use in this machine.
- Carry out regular inspections:
for visible damage,
of safety installations,
of the EMERGENCY STOP push button,
of any components requiring monitoring.
- Pay particular attention to cleanliness during all maintenance and repair work. Cover components and openings with clean cloths, paper or tape to keep them clean.
- Do not leave any loose components, tools or cleaning rags on or in the machine.
- Components removed from the machine can still be dangerous.
Do not attempt to open or destroy any components taken from the machine.

Decommissioning, storage and disposal:

Improper handling of old operating fluids and components represent a danger for the environment.

- Drain off fluids and dispose of them according to applicable environmental regulations. These include, for example, lubricating oil.
- Dispose of the machine in accordance with local environmental regulations.

3.5.3 Organizational measures

- Designate personnel and their responsibilities.
- Give clear instructions on reporting faults and damage to the machine.
- Give instructions on fire reporting and fire-fighting measures.

3.6 Danger areas

The table gives information on areas dangerous to personnel.

Only authorized personnel may enter these areas.

Function	Danger area	Authorized personnel
Transporting	Within a 10 ft radius of the machine.	Installation personnel for transporting preparation. No personnel during transporting.
	Beneath the lifted machine.	No personnel!
Installation	Within the machine. Within 3 ft radius of the machine and its power supply cables.	Installation personnel
Operation	Within a 3 ft radius of the machine.	Operating personnel
Maintenance	Within the machine.	Maintenance personnel
	Within a 3 ft radius of the machine.	

Tab. 22 Danger areas

3.7 Safety devices

Various safety devices ensure safe working with the machine.

- Do not change, bypass or disable safety devices.
- Check safety devices for correct function regularly.
- Do not remove or obliterate labels and notices.
- Ensure that labels and notices are clearly legible.

Further information More information on safety devices is contained in chapter 4, section 4.6.

3.8 Working life of safety functions

Pursuant to ISO 13849-1:2015, Category and Performance Level (PL) of the machine's safety functions have been analyzed and assessed:

Safety function	Category	Performance Level
EMERGENCY STOP push button	1	c

Tab. 23 Category and Performance Level

The safety-relevant functions of the safety devices are designed for a working life of 20 years. The working life starts with the original machine commissioning, and is not extended by times during which the machine was not in use.

The following components are affected:

- EMERGENCY STOP push button
- Option C33, START CONTROL (STC):
Star-delta contactor combination
- Option C34, OMEGA FREQUENCY CONTROL (OFC):
Frequency converter

1. The functions of the safety devices must be replaced by KAESER SERVICE after a working life of 20 years.
2. Have an authorized KAESER service representative check the reliability of the safety functions.

3.9 Safety signs

The illustration shows the location of the safety signs on the machine. Table 24 lists the various safety signs used and their meanings.

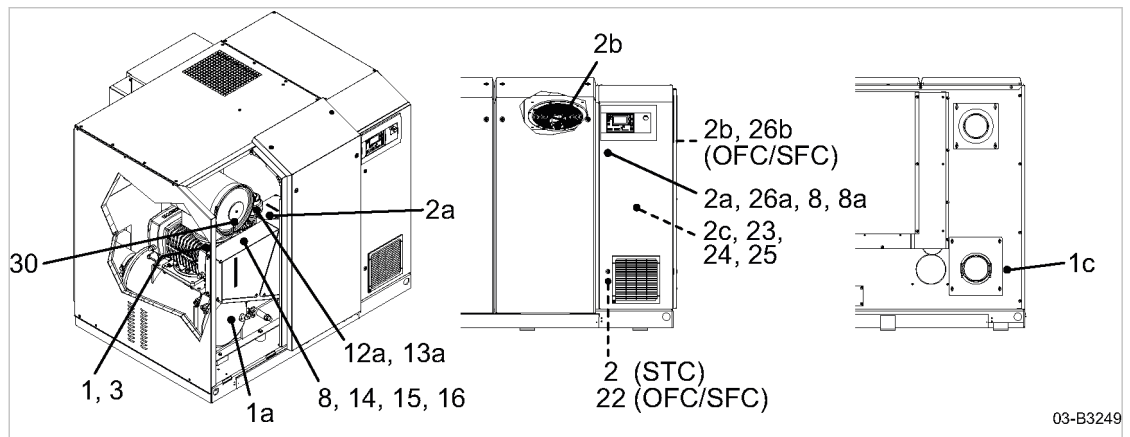

Fig. 3 Location of the safety signs on the machine

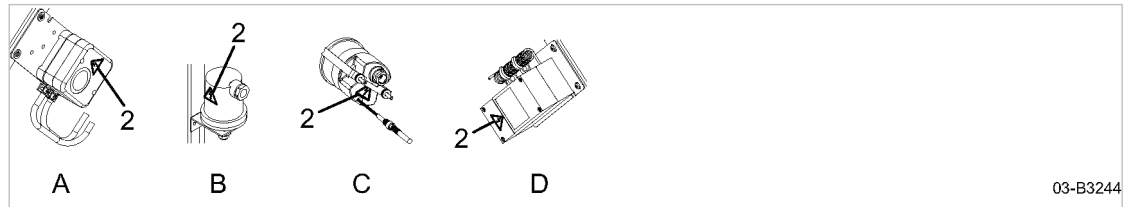

Fig. 4 Safety sign location, electronically actuated components

- | | | | |
|----------|-------------------------------------|----------|--|
| A | Filter differential pressure switch | C | Temperature display with switching point |
| B | Pressure switch | D | Thermostat |

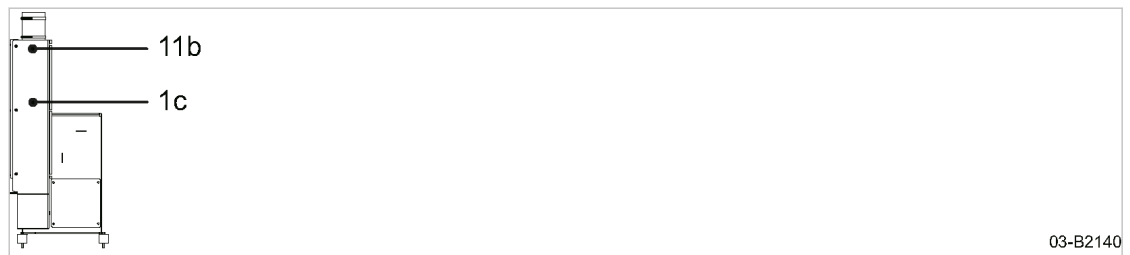

















Fig. 5 Safety sign position, blow-off silencer, Option H16, H19

Location	Symbol	Meaning
1 1a 1c		Hot surface can cause burns! ➤ Let the machine cool down. ➤ Wear long-sleeved garments (not synthetics such as polyester) and protective gloves.

Location	Symbol	Meaning
2 2a 2b 2c		Danger of fatal injury from touching electrically live components! <ul style="list-style-type: none"> ➤ Switch off and lock out / tag out the power supply disconnecting device and verify the absence of any voltage before opening any machine enclosure or guard.
3		Rotating rotors! Risk of serious lacerations or even severing of extremities (fingers) from rotating components. <ul style="list-style-type: none"> ➤ Operate the machine only when a connection is made to the inlet port. ➤ Switch off and lock out / tag out the power supply disconnecting device and verify the absence of any voltage before opening any machine enclosure or guard.
8		Personal injury or damage to the machine by incorrect operation! <ul style="list-style-type: none"> ➤ Read and understand the service manual and all safety signs before switching on this machine.
8a		Machine starts automatically! Severe injury can result from rotating components, electrical voltage, and air pressure. <ul style="list-style-type: none"> ➤ Switch off and lock out / tag out the power supply disconnecting device and verify the absence of any voltage before opening any machine enclosure or guard.
11b		Hot gas! Burning, from contact with hot gasses. <ul style="list-style-type: none"> ➤ Do not enter danger zone. ➤ Wear long-sleeved garments (not synthetics such as polyester) and protective gloves.
12a		Serious injury or death can result from loosening or opening component that is under pressure and heavily spring loaded! <ul style="list-style-type: none"> ➤ Do not open or dismantle the valve. ➤ Contact an authorized KAESER service representative if a fault occurs.
13a		Serious injury or death can result from loosening or opening component under pressure! <ul style="list-style-type: none"> ➤ Depressurize all pressurized components and enclosures. ➤ Ensure the machine remains depressurized. ➤ Check that machine is depressurized.
14		Severe injury could result from touching the v-belt drive while it is rotating! <ul style="list-style-type: none"> ➤ Switch off and lock out / tag out the power supply disconnecting device and check that no voltage is present.
15		Injury and/or contamination can result from breathing compressed air! Contamination of food can result from using untreated compressed air for food processing! <ul style="list-style-type: none"> ➤ Never breathe untreated compressed air. ➤ Air from this compressor must meet OSHA 29CFR1910.134 and FDA 21CFR178.3570 standards, if used for breathing or food processing. Use proper compressed air treatment.

Location	Symbol	Meaning
16		Noise due to opened service panel of the sound enclosure (Option H12)! ► Hearing may be damaged. ► Wear hearing protection.
22		High protective conductor current! Touching electrically live components can cause serious injury or death. ► Switch off and lock out / tag out the power supply disconnecting device and check that no voltage is present. ► Wait at least 5 minutes. ► Verify the absence of any voltage.
23		Danger of fatal injury from touching electrically live components! ► Switch off and lock out / tag out the power supply disconnecting device and verify the absence of any voltage.
24		Risk of electric shock! ► If the interrupter has tripped current-carrying components of the controller should be examined and replaced if damaged to reduce the risk of fire or electric shock.
25		Risk of electric shock! ► To maintain high current short-circuit, and ground-fault protection, the manufacturer's instructions for setting the interrupter must be followed to reduce the risk of fire or electric shock.
26a 26b		Danger of fatal injury from electrical voltage and charged capacitors! ► Before starting any work on the electrical equipment: Switch off the power supply disconnecting device, lock out / tag out the device, verify the absence of any voltage. ► Following shutdown of the power supply disconnecting device, wait for 5 minutes before opening the control cabinet/connector box. ► Before starting work on the frequency converter or intermediate circuit capacitors, wait for at least 5 minutes.
30		Danger of bursting from excessive pressure! ► Always remove the inlet silencer cover when checking the direction of rotation.

Tab. 24 Safety signs

3.10 In emergency

3.10.1 Correct fire fighting

Suitable extinguishing agents

- Foam
- Carbon dioxide
- Sand or dirt

Unsuitable or unsafe extinguishing agents

- Strong jet of water

1. Keep calm.
2. Give the alarm.
3. Switch off the power supply disconnecting device, if possible.
4. Move to safety.
 - Warn persons in danger.
 - Help incapacitated persons.
 - Close the doors.
5. Try to extinguish the fire if you have the skill to do so.

3.10.2 Remove lubricating oil from the skin.

- Eye contact:
Rinse eyes thoroughly with lukewarm water and seek medical assistance.
- Skin contact:
Wash off immediately.

3.11 Environmental protection

- Store and dispose of operating materials and replaced parts in accordance with local environmental protection regulations.
- Observe national regulations.
This applies particularly to parts contaminated with lubricating oil.



- Do not allow lubricating oil to escape to the environment or into the sewage system.

3.12 Warranty

This operator manual contains no independent warranty commitment. Our general terms and conditions of business apply with regard to warranty.

A condition of our warranty is that the machine is used for the purpose for which it is intended under the conditions specified.

Due to the multitude applications for which the machine is suitable the obligation lies with the user to determine its suitability for his specific application.

In addition, we accept no warranty obligation for:

- the use of unsuitable parts or operating materials,
- unauthorized modifications,
- incorrect maintenance,
- incorrect repair.

Correct maintenance and repair includes the use of original spare parts and operating materials.

- Obtain confirmation from KAESER that your specific operating conditions are suitable.

4 Design and Function

4.1 Enclosure

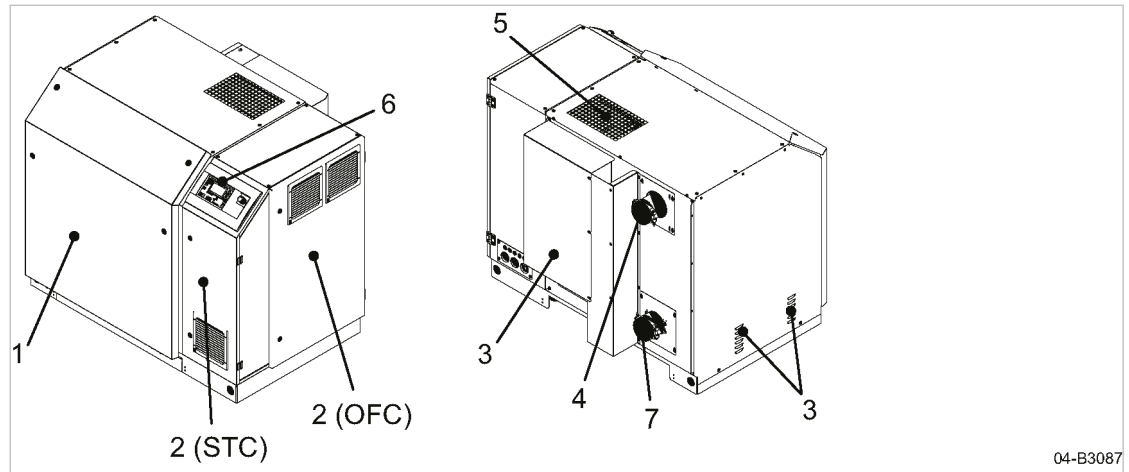

Fig. 6 Enclosure

- | | | | |
|---|----------------------|---|----------------------------|
| ① | Removable panel | ⑤ | Cooling air outlet |
| ② | Control cabinet door | ⑥ | Controller SIGMA CONTROL 2 |
| ③ | Cooling air inlet | ⑦ | Exhaust air outlet |
| ④ | Intake air inlet | | |

The sound enclosure has a removable panel ①.
 The control cabinet door ② can be swung open.
 Latches are released by a key supplied with the machine.

The sound enclosure has several functions when it is closed:

- Sound insulation
- Protection against contact with components
- Airflow control

The sound enclosure is not suitable for the following uses:

- Walking, standing, or sitting on the machine.
- Use as a resting place or storage of any kind of load.

Process air flow

Intake air is drawn into the inlet silencer via the intake line.
 Air is discharged through the exhaust air outlet ⑦.

Cooling air flow

The motor fan draws cooling air through the cooling air inlet ③ into the sound enclosure to cool the drive motor and the machine.

Cooling air flow is supplemented by a fan within the enclosure. Warm air is blown out to protect the machine from overheating.

4.2 SIGMA CONTROL 2 operating panel

4.2.1 Keys

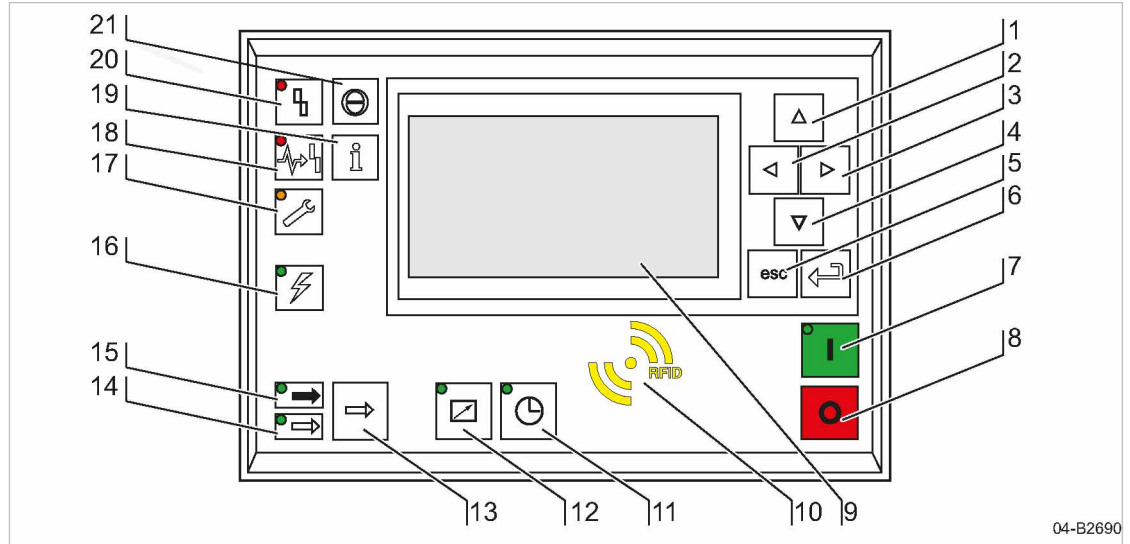

Fig. 7 Indicating and operating elements

Item	Name	Function
①	«Up»	Scrolls up the menu options. Increases a parameter value.
②	«Left»	Jumps to the left. Moves the cursor position to the next left field.
③	«Right»	Jumps to the right. Moves the cursor position to the next right field.
④	«Down»	Scrolls down the menu options. Reduces a parameter value.
⑤	«Escape»	Returns to the next higher menu option level. Exits the Edit mode without saving.
⑥	«Enter»	Jumps to the selected menu option. Exits the Edit mode and saves.
⑦	«ON»	Switches the machine on.
⑧	«OFF»	Switches the machine off.
⑩	RFID	RFID sensor field for user log-in with RFID Equipment Card.
⑪	«Timer control»	Switches timer control on and off.
⑫	«Remote control»	Switches remote control on and off.
⑬	«LOAD/IDLE»	Toggles between the LOAD and IDLE operating modes.
⑰	«Information & Events»	Displays the event memory.
⑳	«Reset»	Signifies recognition of alarms and warning messages. If permissible: Resets the fault counter (RESET).

Tab. 25 Controls

4.2.2 LEDs

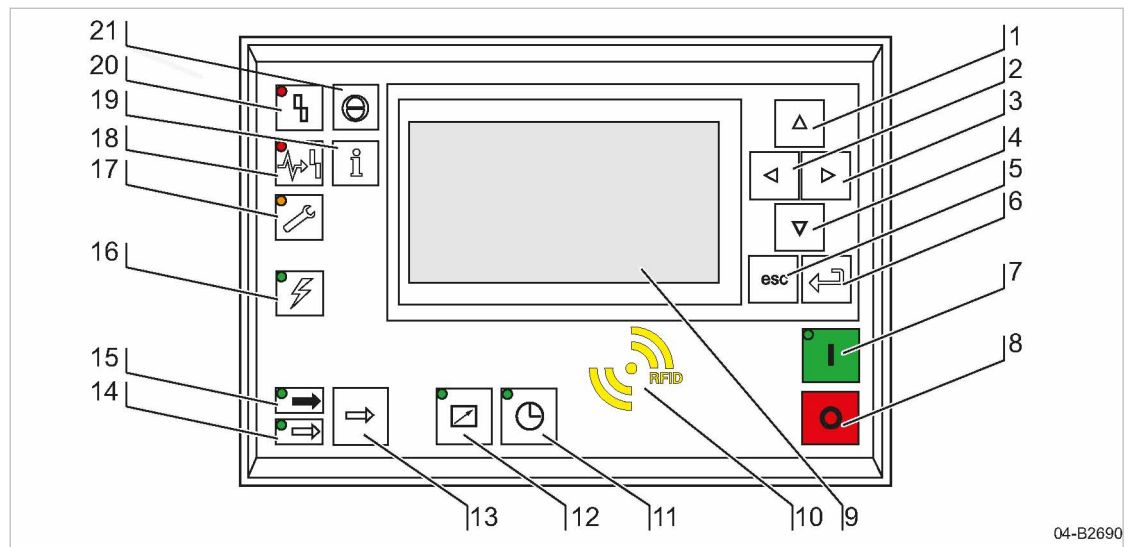

Fig. 8 Indicating and operating elements

Item	Name	Function
7	ON	Display illuminates green when the machine switched on.
9	Display	Graphic display with 8 lines and 30 characters per line.
11	Timer control	Continuous green light when the machine is controlled by the timer.
12	Remote control	Continuous green light when the machine is in remote control.
14	IDLE	Continuous green light when the machine is running in IDLE. Flashes when the «LOAD/IDLE» toggle key is pressed.
15	LOAD	Continuous green light when the machine is running in LOAD.
16	Controller on	Continuous green light when voltage is applied to the controller.
17	Warning	Flashes in yellow in the following events: <ul style="list-style-type: none"> ■ Maintenance necessary. ■ Warning message
18	Communications error	Continuous red light to indicate a faulty communication connection without machine shut-down.
20	Fault	Flashes red to indicate a machine fault. Continuous red light after acknowledgement.

Tab. 26 Display elements

4.2.3 RFID sensor field

RFID is the abbreviation for “Radio Frequency Identification” and enables the identification of persons or objects.

Placing a suitable transponder in front of the RFID sensor field of the controller will automatically activate the communication between transponder and SIGMA CONTROL 2.

A suitable transponder is the RFID Equipment Card. Two of them have been provided with the machine.

Typical application:

- Operators log on at the machine.
(Manual input of the password not required)



The RFID Equipment Cards are carefully packed in a plastic sleeve. This plastic sleeve is attached to the rear of the controller in the control cabinet.

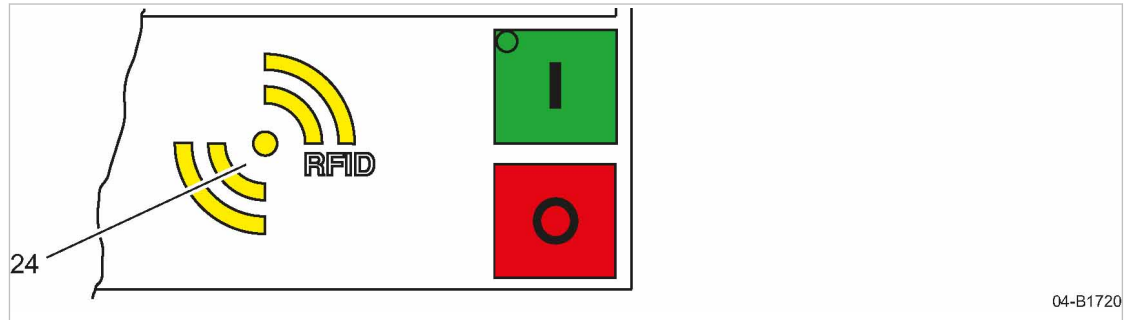

Fig. 9 RFID sensor field

Item	Name	Function
24	RFID	RFID sensor field for the communication with a RFID Equipment Card or RFID Key.

Tab. 27 RFID sensor field

Further information More information about the use of RFID technology is provided in the SIGMA CONTROL 2 operating manual.

4.3 Machine

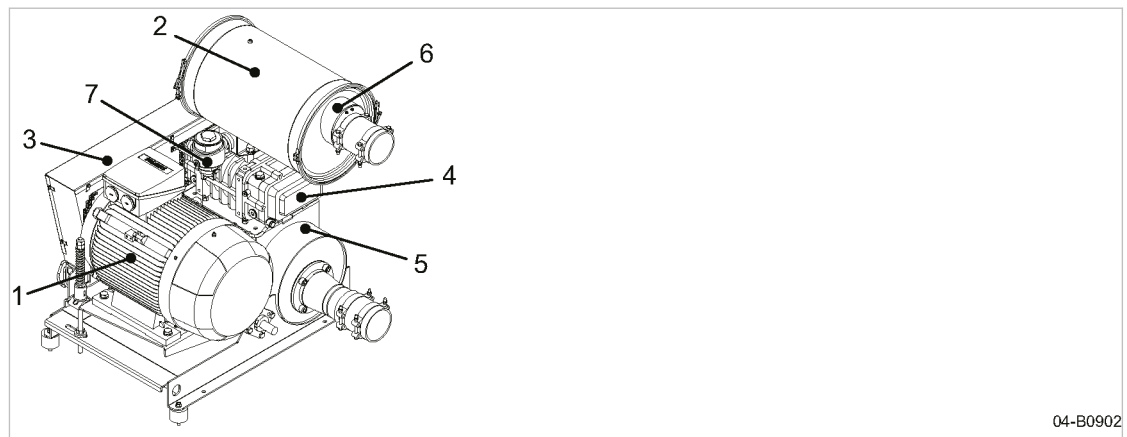

Fig. 10 Machine

- | | |
|------------------|---------------------------|
| ① Drive motor | ⑤ Outlet silencer |
| ② Inlet silencer | ⑥ Check valve (Option G1) |
| ③ Belt guard | ⑦ Safety relief valve |
| ④ Blower block | |

The drive motor (electric motor) ① drives the blower block ④ via a belt drive. Air is drawn into the inlet silencer ② via an air filter where it is cleaned.

The air is then pushed from the blower block in a vertical direction into the outlet silencer (5), where the process induces pressure build-up.

4.4 Blower block

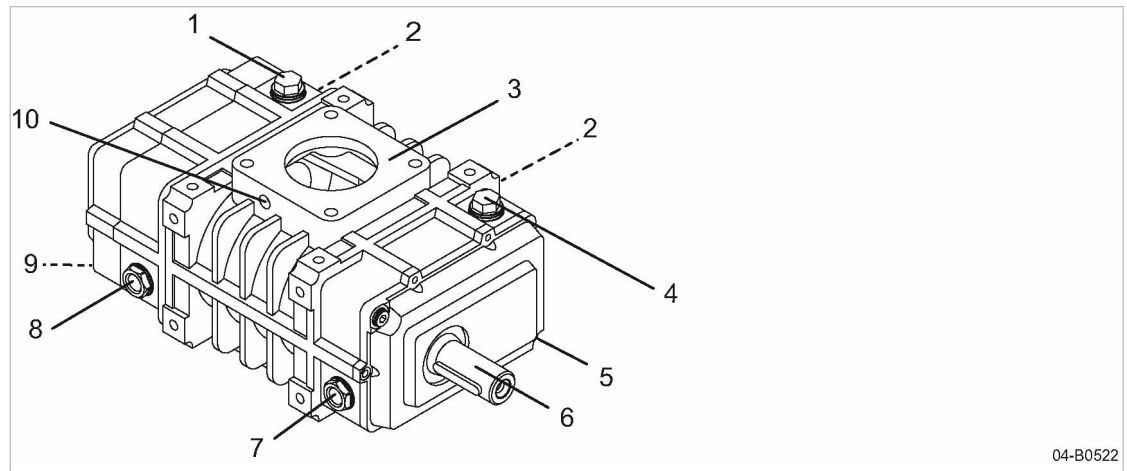

Fig. 11 Blower block

- | | |
|----------------------------------|--|
| ① Gear-end oil inlet | ⑥ Drive shaft |
| ② Side gas drainage (closed) | ⑦ Drive-end oil sight glass |
| ③ Flange connection (both sides) | ⑧ Gear-end oil sight glass |
| ④ Drive-end oil inlet | ⑨ Gear-end oil drain |
| ⑤ Drive-end oil drain | ⑩ Connection for measuring instrument (both sides) |

A pair of rotors with intermeshing lobes turn in opposite directions within a casing. The rotors are synchronized by timing gears on one end. Air in the block inlet is trapped between the rotor lobes and the casing and moved round to the discharge port.

As there is no contact between the rotors themselves and the casing, oil film lubrication is not required.

4.5 Safety relief valve

The safety relief valve protects the vacuum system from excessive vacuum. It is factory set.

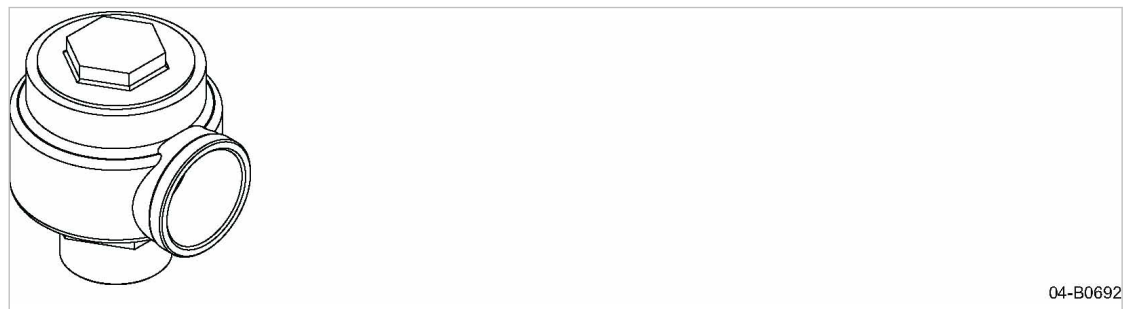

Fig. 12 Safety relief valve

4.6 Safety devices

The following safety devices are provided and may not be modified in any way:

- Safety relief valve:
This valve protects the vacuum system from excessive vacuum. It is factory set.
- Covers over moving parts and electrical connections:
These protect against accidental contact.
- Sound enclosure (Option H12):
The sound enclosure prevents excessive noise emission.
- Drive motor with 3 PTC thermistors:
Motor protection against overheating in connection with the user's protection cut-out.

4.7 Compensator

The compensator functions as follows:

- Inlet and outlet connections to silencers and accessories
- Isolates the machine vibrations from the air pipeline

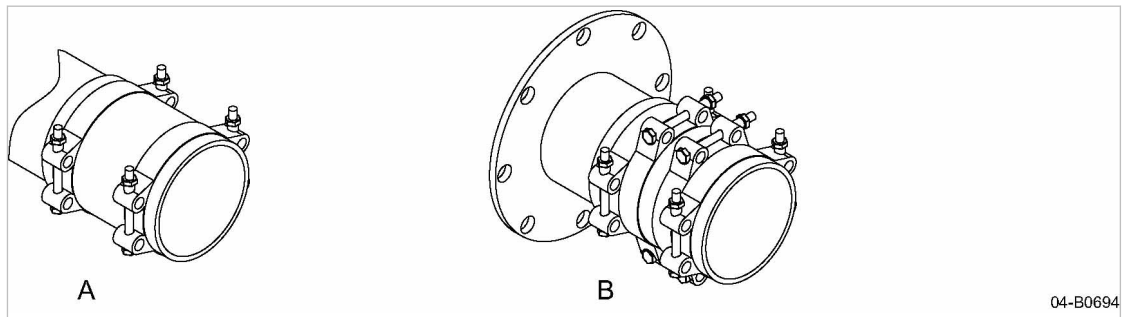

Fig. 13 Compensator

- (A) Compensator, suction side
- (B) Compensator, exhaust side

4.8 Automatic starting

Depending on the settings in the controller, the machine can automatically start after a power failure or external deactivation.

You must be logged in with the RFID Equipment Card in order to activate or deactivate this option. Option deactivated (factory setting):

- Machine remains deactivated after a network power failure.

Option activated:

- Machine automatically restarts after the voltage supply has returned.

Further information Note the instructions in the operating manual supplied with SIGMA CONTROL 2 for activating and deactivating this function.

4.9 Floating relay contacts

Floating relay contacts are provided for the transfer of operational state (messages). Information on location, loading capacity, and type of contact can be found in the electrical diagram.



If the floating relay contacts are connected to an external voltage source, voltage may be present even when the machine is isolated from the power supply.

4.10 Options

The options available for your machine are described below.

4.10.1 Option C5 Oil level monitor

The oil level switch monitors the level of lubricating oil in the blower block. This electronic monitoring does not relieve the obligation to perform regular manual checks of the lubricating oil level.

Two float-type level sensors monitor the level of oil in the drive and gear-end oil chambers. If the oil level falls below the minimum level, a switching contact is opened.

The controller registers the signal, displays an alarm message and shuts down the machine.

4.10.2 Option C10 Speed monitor

The speed monitor measures the rotational speed of the block rotors.

If the set minimum speed is not reached, the controller displays an alarm message and shuts down the machine.

4.10.3 Option G1 Check valve

The check valve prevents a reversal of the normal air flow direction.

The valve is closed when the machine is at standstill.

The check valve is integrated in the intake silencer.

4.10.4 Option H11 Piped inlet

Air is drawn into the block through the inlet silencer.

4.10.5 Option H16, H12 Exhaust silencer (pipeline)

The exhaust silencer reduces noise emission.

⚠ WARNING

Danger of burns from hot components!

- *Wear long-sleeved clothing and protective gloves.*

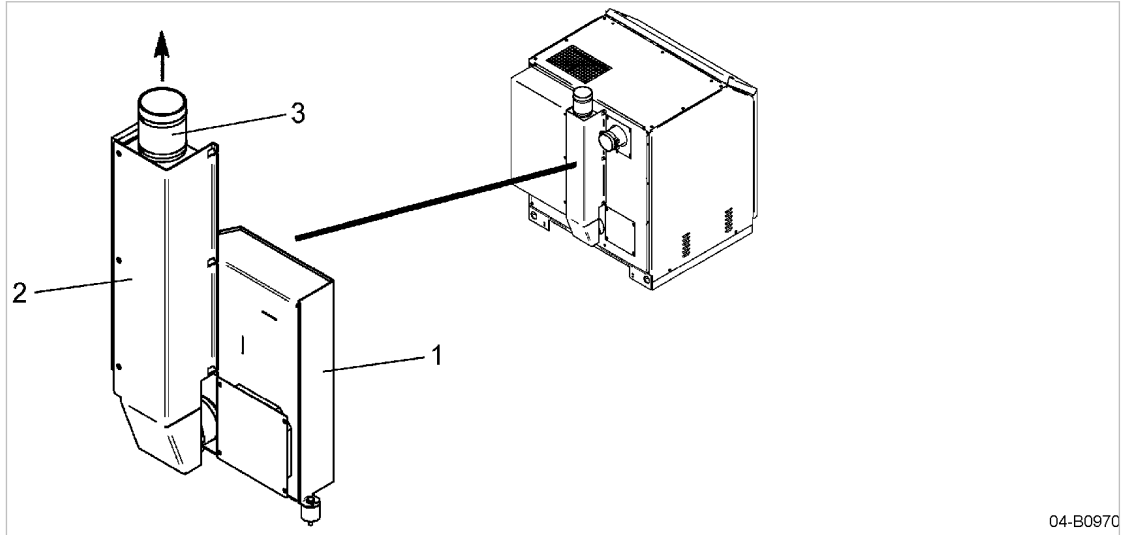

04-B0970

Fig. 14 Exhaust silencer (pipeline)

- ① Silencer
- ② Exhaust air duct
- ③ Compensator
(connection to pipeline)

The exhaust air generated during the compression (vacuum) process passes through a compensator ③ on the silencer ① into a flexible pipeline.

The exhaust air can reach temperatures up to a max. of 320°F in the silencer.

4.10.6 Option H19, H12 Exhaust silencer (diffusion to surroundings)

The exhaust silencer reduces noise emission.

⚠ WARNING

Danger of burning from hot components and scalding from escaping oil.

- *Wear long-sleeved clothing and protective gloves.*
- *Do not inhale the exhaust air.*

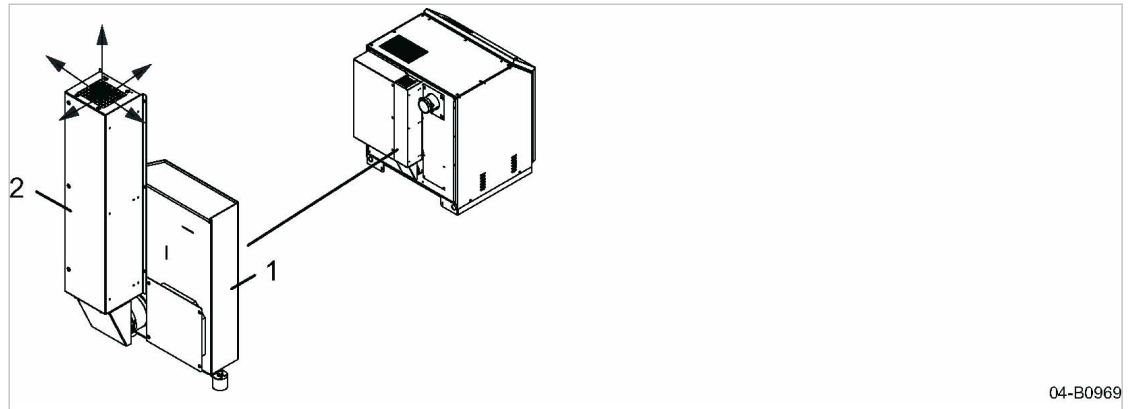

04-B0969

Fig. 15 Exhaust silencer (diffusion to surroundings)

- ① Silencer
- ② Exhaust air duct

The exhaust air generated during the compression (vacuum) process is diffused out through the silencer ② into the surrounding atmosphere.

The exhaust air may reach temperatures up to a max. of 320°F.

5 Installation and Operating Conditions

5.1 Ensuring safety

The conditions in which the machine is installed and operated have a decisive impact on safety. Warning instructions are located before a potentially dangerous task.



Disregard of warning instructions can cause serious injuries!

Complying with safety instructions

Disregard of safety warnings can cause unforeseeable dangers!

- Strictly forbid fire, open flame and smoking.
- If welding is carried out on or near the machine, take adequate measures to prevent sparks or heat from igniting oil vapors or parts of the machine.
- Do not store flammable material in the vicinity of the machine.
- The machine is not explosion-proof!
Do not operate in areas in which specific requirements with regard to explosion protection are in force.
- Ensure sufficient and suitable lighting such that the display can be read and work carried out comfortably and safely.
- Keep suitable fire extinguishing agents ready for use.
- Comply with the permissible ambient and intake conditions.
- Ensure the correct composition of the intake air:
 - Clean with no damaging contaminants (e.g., dust, fibers, fine sand).
 - Free of explosive or chemically unstable gases or vapors.
 - Free of acid/alkaline forming substances, particularly ammonia, chlorine or hydrogen sulfide.

Noise

The sound enclosure absorbs and reduces the machine noise to a comfortable level. This function will be effective only if the sound enclosure is closed.

- If necessary, wear hearing protection or take hearing protection measures on-site.

5.2 Installation conditions

5.2.1 Determining installation location and clearances

The machine is intended for installation in a suitable machine room. Information on wall clearances and ventilation is given below.



The clearances specified are recommended clearances and ensure unhindered access to all machine parts.

- Please consult KAESER if you cannot comply with these recommendations.

Precondition The floor must be level, firm and capable of bearing the weight of the machine. No special foundations are necessary.

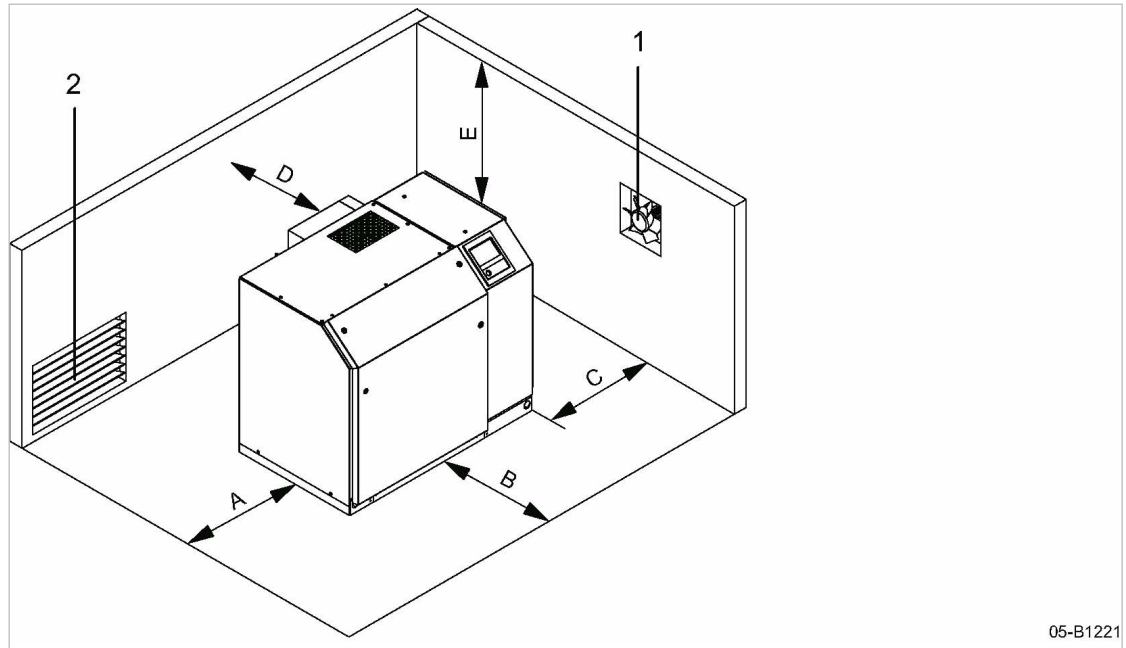

Fig. 16 Recommended positioning of the machine, minimum dimensions [in.]

- | | |
|------------------|-----------------------------------|
| (A) See Table 28 | (E) 27.6 |
| (B) 35.4 | (1) Exhaust fan |
| (C) See Table 28 | (2) Ventilation inlet air opening |
| (D) 32.0 | |

➤ Determine clearances (A) and (C).

Characteristic, option	Recommended positioning of the machine, minimum dimensions
C33, START CONTROL (STC)	Distance (A) or (C) must be a minimum of 27.6 in.. Version 1: (A) = 2.0 in. and (C) = 27.6 in. Version 2: (A) = 27.6 in. and (C) = 2.0 in.
C34, OMEGA FREQUENCY CONTROL (OFC)	(A) = 2.0 in. (C) = 32.0 in.

Tab. 28 Recommended positioning of the machine, minimum dimensions

- If the ambient temperature is too low: Ensure that the compressor room is adequately heated.
- Ensure accessibility so that all work on the machine can be carried out hazard-free and without obstruction.
- Do not position the machine in the hot exhaust air flow from other machines.
- When installing multiple machines, ensure that all inlet and exhaust air openings are arranged on one side.
- Observe any additional clearances that may be specified in local occupational health & safety and building regulations, so that escape and rescue routes may safely be accessed, even when the machine enclosure is open.

5.2.2 Ensuring adequate ventilation

If the ventilation is insufficient, a partial vacuum can be created in the machine room.

- Ensure that the flow rate of inlet air is at least the same as the flow rate taken by the machine and exhaust fan from the machine room.
- Ensure that a sufficient amount of oxygen is available for any individuals entering the machine room.
- Ensure that the machine and exhaust fan can only be operated when the ventilation inlet air opening is open.
- Keep the inlet and exhaust openings free from obstructions so that the cooling air can flow freely through the machine room.

6 Installation

6.1 Ensuring safety

Follow these instructions to ensure safe installation.

Warning instructions are provided prior to any potentially dangerous task.



Disregard of warning instructions can result in life-threatening injuries!

Observing safety warnings

Ignoring safety warnings can result in unforeseen dangers.

- Follow the instructions in chapter 3 "Safety and Responsibility".
- Installation work must only be carried out by authorized personnel!
- Ensure that no personnel are working on the machine.
- Ensure that all cover panels are closed.

Working on live components

Touching live components can result in electric shocks, burns or death.

Dangerous voltages remain in the frequency converter and intermediate circuit capacitors for some time after the power has been disconnected.

When the frequency converter is open, live components are exposed.

- Work on electrical equipment may only be carried out by authorized electricians.
- Switch off the power supply disconnecting device, lock out / tag out the device, verify the absence of any voltage.
- Before starting work on the frequency converter or intermediate circuit capacitors, wait for at least 5 minutes.
- Check that there is no voltage on floating contacts.

Working at the vacuum system

The following safety instructions relate to any work on components that could be under pressure.

- Switch off the power supply disconnecting device, lock out / tag out the device, verify the absence of any voltage.
- Vent all components and chambers under vacuum to atmospheric pressure.
- Do not open or dismantle any valves.

Working on the drive system

Touching live components can result in electric shocks, burns or death.

Touching the fan wheel or the belt drive while the machine is running can result in serious injury.

- Switch off the power supply disconnecting device, lock out / tag out the device, verify the absence of any voltage.

- Do not open any of the cover panels while the machine is switched on.
- If full protection is only provided when the machine is completely installed, then in all other phases of the machine's life-cycle temporary protective devices (e.g. covers) must be fitted, in order to guarantee that parts of the body cannot reach or be caught/sucked in by the rotary lobes.

Further information Information regarding authorized personnel can be found in chapter 3.4.2.
Information regarding dangers and their avoidance can be found in chapter 3.5.

6.2 Reporting transport damage

1. Check the machine for visible and hidden transport damage.
2. Inform the carrier and the manufacturer in writing of any damage without delay.

6.3 Anchoring the machine

The machine may be anchored to the floor.

The following anchoring elements are shipped with the machine:

Foundation bolts for machines without sound enclosure.

Foundation bolts and angle brackets for machines with sound enclosure.

- Use the anchoring elements to anchor the machine without stress.

Further information Details of the fixing holes are contained in the dimensional drawing in chapter 13.2.

6.4 Connecting the power supply

Precondition The power supply disconnecting device is switched off, lock out and tag out the device, the absence of any voltage has been verified.
The tolerance limits of the power supply are within the tolerance limits of the rated machine voltage.

Option C34, OMEGA FREQUENCY CONTROL (OFC):

The voltage in the intermediate circuit capacitors of the frequency converter is reduced.

1. The power supply must only be connected by authorized installation personnel or authorized certified electricians.
2. Carry out protection measures as stipulated in relevant regulations and in national accident prevention regulations. In addition, observe the regulations of the local electricity supplier.
3. Select supply cable conductor cross-sections and fusing in accordance with local regulations and chapter 2.12.
4. Test the overcurrent protective device to ensure that the time it takes to shut down in response to a fault is within the permitted limit.
5. The user is required to fit the machine with a lockable power supply disconnecting device. This could be, for example, a load disconnect switch with fused input. If a circuit breaker is used it must be suitable for the motor starting characteristics.
6. Check that the control transformer is connected according to the supply voltage.
If not, reconnect the control transformer to suit the power supply voltage.

7. **⚠ DANGER** *Danger of fatal injury from electric shock!*
 - *Switch off and lock out the power supply disconnecting device and verify the absence of voltage.*
8. Connect the machine to the power supply.
9. Properly close openings, cable glands, etc.

Further information The wiring diagram in chapter 13.4 contains further details of the power supply connection.

Connecting the control cabinet

The machine can be operated at full power at the rated voltage with a tolerance of $\pm 5\%$.

If the supply voltage deviates from the rated voltage, the control transformer's (component T11) cable bridge should be changed to correspond to the actual main power supply.

1. Select supply cable conductor cross-sections and fusing in accordance with local regulations and chapter 2.12.
2. Connect the control cabinet (note clockwise phase rotation!).

6.4.1 Option C32 Under frequency control



If the machine is delivered by KAESER including the frequency converter, the regulation behavior and operating mode of the frequency converter will be preset.

- Adapt and optimize the actual properties to the customer system on-site.
- Comply with the following provisions if you operate machines with a frequency converter:
 - Operate the machine only within its performance limits and under the permitted ambient conditions.
 - The speed change should be approx. 5 Hz per second. This value applies also for the starting ramp from standstill to reaching minimum frequency. Deviating settings, either slower or faster, may be possible after verification by an authorized KAESER SERVICE representative.
 - The frequency converter may be switched to a motor in standstill only, in order to avoid malfunctions.
 - The automatic restart of the machine is **not** preset for safety-relevant reasons.

6.5 Connecting to the vacuum network

Material Torque wrench

Precondition Vacuum network at atmospheric pressure.



Non-return or check valves must be installed in systems that are to remain under vacuum when the machine is shut down.

- Consult an authorized KAESER service representative on a suitable check valve and expert installation.

6 Installation

6.6 Sound enclosure: Removing transport securing devices

1. Make the vacuum network connection with compensator or flexible hose line and install with the following torques:

Connection to customer's pipeline	Torque [lbf-ft]
Compressor with hose clamps	22
Compressor with screwed joint M20*	—

* Manually tighten screws equally, torque at 37 lbf-ft and subsequently retighten crosswise with torque according to table.

Tab. 29 Compensator torques

2. Support the weight of the pipework and any other connecting components.
3. Install a suitable pipeline to lead discharge air outdoors.

Further information The dimensional drawing in chapter 13.2 provides information regarding the connection of the pipeline.

6.6 Option H12 Sound enclosure: Removing transport securing devices

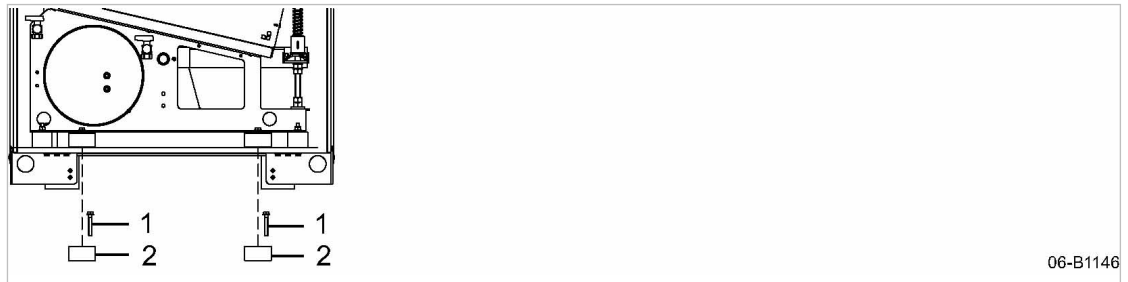

Fig. 17 Removing the transport securing devices

- ① Screw
- ② Spacer

Remove the transport securing devices after the machine has been installed.

1. Remove the access panel of the sound enclosure.
2. Remove the transport securing device and store for future transports.

6.7 Option H12 Fitting the cover plate

A cover plate for the transport opening at the machine's base frame is included with the delivery. Fit this cover plate after the machine has been installed.

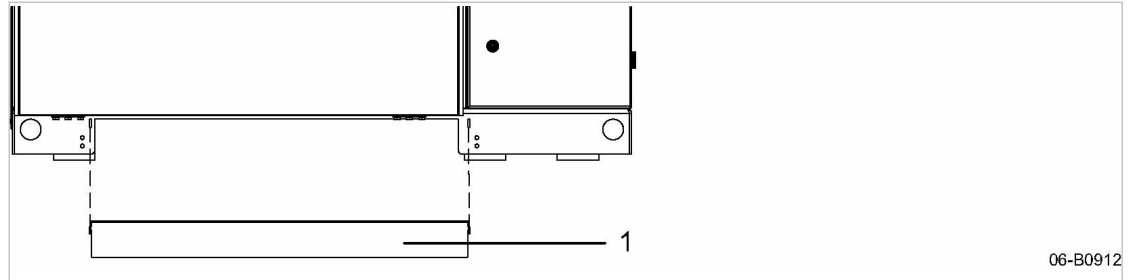

06-B0912

Fig. 18 Fitting the cover plate

① Cover plate

- Screw the cover plate to the base frame.

7 Initial Start-up

7.1 Ensuring safety

This chapter provides instructions for safe commissioning of the machine. Warning instructions are provided prior to any potentially dangerous task.



Disregard of warning instructions can result in life-threatening injuries!

Observing safety warnings

Ignoring safety warnings can result in unforeseen dangers.

- Follow the instructions in chapter 3 “Safety and Responsibility”.
- Commissioning tasks may only be carried out by authorized installation personnel!
- Ensure that no personnel are working on the machine.
- Ensure that all cover panels are closed.

Working on live components

Touching live components can result in electric shocks, burns or death.

Dangerous voltages remain in the frequency converter and intermediate circuit capacitors for some time after the power has been disconnected.

When the frequency converter is open, live components are exposed.

- Work on electrical equipment may only be carried out by authorized electricians.
- Switch off the power supply disconnecting device, lock out / tag out the device, verify the absence of any voltage.
- Before starting work on the frequency converter or intermediate circuit capacitors, wait for at least 5 minutes.
- Check that there is no voltage on floating contacts.

Working at the vacuum system

The following safety instructions relate to any work on components that could be under pressure.

- Switch off the power supply disconnecting device, lock out / tag out the device, verify the absence of any voltage.
- Vent all components and chambers under vacuum to atmospheric pressure.
- Do not open or dismantle any valves.

Working on the drive system

Touching live components can result in electric shocks, burns or death.

Touching the fan wheel or the belt drive while the machine is running can result in serious injury.

- Switch off the power supply disconnecting device, lock out / tag out the device, verify the absence of any voltage.

- Do not open any of the cover panels while the machine is switched on.
- If full protection is only provided when the machine is completely installed, then in all other phases of the machine's life-cycle temporary protective devices (e.g. covers) must be fitted, in order to guarantee that parts of the body cannot reach or be caught/sucked in by the rotary lobes.

Further information Information regarding authorized personnel can be found in chapter 3.4.2.
 Information regarding dangers and their avoidance can be found in chapter 3.5.

7.2 Instructions to be observed before commissioning

Incorrect or improper commissioning can cause injury to persons and damage to the machine.

- Commissioning may be carried out only by authorized installation and service personnel who have been trained on this machine.

Special measures for recommissioning after storage/standstill

Storage period/ standstill longer than	Measure
12 months	<ul style="list-style-type: none"> ➤ Change the lubricating oil. ➤ Re-grease the drive motor bearings if they are not of the permanently-greased type. ➤ Check the condition and tension of the drive belts. ➤ Have the frequency converter smoothing capacitors formed (refreshed) by an authorized KAESER service representative.
36 months	<ul style="list-style-type: none"> ➤ Have the overall technical condition checked by an authorized KAESER service representative.

Tab. 30 Recommissioning after storage/standstill

7.3 Checking installation and operating conditions

- Check and confirm all the items in the checklist before commissioning the machine.

To be checked	See chapter	Confirmed?
➤ Have all packing materials, tool and transport securing means been removed from the machine?	—	
➤ Are the operators completely familiar with safety regulations?	—	
➤ Have all the positioning conditions been fulfilled?	5	
➤ Is the machine anchored to the floor without stress?	6.3	
➤ Are the tolerance limits of the power supply within the permissible tolerance limits of the rated machine voltage?	—	
➤ Are the power supply cable conductor cross-sections and fuse ratings sufficient?	2.12	

To be checked	See chapter	Confirmed?
➤ Is a user-supplied lockable power supply disconnecting device installed?	6.4	
➤ Has the control cabinet connection been checked?	6.4	
➤ Has a suitable non-return valve been installed professionally?	6.5	
➤ Has the connection to the vacuum network been made with a hose or compensator?	6.5	
➤ Has the drive motor's direction of rotation been checked?	7.7	
➤ Have all electrical connections been checked for tightness? (The check must be repeated after 50 operating hours)	—	
➤ Is there adequate lubricating oil in the gear and drive-end of the blower block? (Check oil sight glass)	10.6	
➤ Has the drive belt tension been checked? (The check must be repeated after 24 operating hours)	10.5	
➤ Have the removable access panel of the sound enclosure and other panels been inserted and locked? (Option H12)	4.1	

Tab. 31 Installation conditions check list

7.4 Re-greasing the motor bearings

- The motor bearings of motors with re-greasing facility must be re-greased with bearing grease prior to the initial commissioning of the machine.

Further information Further information on re-greasing motor bearings can be found in chapter 10.12.1.

7.5 Configuring the controller

- Configure the controller as described in the SIGMA CONTROL 2 operating manual.

7.6 Setting the display language

The controller can display message text in several languages.

You can set the language for texts on the display. This setting will be retained even when the machine is switched off.

1. In operating mode, switch to the main menu with the «Enter» key.

2. Press the «UP» or «DOWN» keys until the current language is shown as active line:

6.1 bar	80.0 °C	
Deutsch		Current language (active line)
▶1	xxxxxxxxxx	Submenu
▶2	xxxxxxxxxx	Submenu
▶3	xxxxxxxxxx	Submenu
▶4	xxxxxxxxxx	Submenu
▶5	xxxxxxxxxx	Submenu
▶6	xxxxxxxxxx	Submenu

3. Use the «Enter» key to switch to setting mode.
The language display flashes.
4. Move to the required language with «UP »or «DOWN».
5. Confirm the setting with the «Enter» key.

Result The display texts are now in the selected language.

Further information Detailed information can be found in the SIGMA CONTROL 2 operating manual.

7.7 Checking the direction of rotation for the drive motor

The machine is designed for a clockwise phase sequence.

An arrow showing the correct direction of rotation is indicated on the drive-side of the blower block and on the belt guard.

Should the direction of rotation for the drive motor be wrong, the direction of flow through the machine will be reversed and pressure will rise in the inlet pipe.

A phase sequence relay is installed in the machine control cabinet, which only sends a release signal to the controller when a clockwise direction of rotation is detected.

The controller will report a fault if the direction of rotation is counterclockwise. In this case, exchange phases L1 and L2 of the supply line(s). The fault can then be acknowledged.

Material Phase sequence indicator

NOTICE

Incorrect direction of rotation!

This may result in damage to the machine from intake of foreign articles or excessive vacuum.

➤ *Ensure the correct direction of rotation.*

1. Remove the filter maintenance cover from the inlet silencer or inlet filter and/or remove the non-return valve on the inlet side.
2. Verify the direction of rotation using a phase sequence indicator on the machine supply lines.
3. If the direction of rotation is incorrect, exchange phases L1 and L2 of the supply lines.



If you do not have access to a phase sequence indicator:

➤ Arrange for the phase sequence to be checked by an authorized KAESER service representative.

7.8 Option C33**START CONTROL (STC): Setting the overload protection cut-out**

The electrical diagram 13.4 gives the location of the overload protection cut-out.

With star-delta starting, the phase current is fed via the overload protection relay. This phase current is 0.58-times the rated drive motor current.

To prevent the overload relay being triggered by voltage fluctuations, temperature influences or component tolerances, the setting can be higher than the arithmetical phase current.

➤ Check the overload protection relay setting.



The overload protection relay shuts the machine down despite being correctly set?

➤ Contact an authorized KAESER service representative.

7.9 Starting the machine for the first time

Precondition No personnel are working on the machine.
All access doors are closed.
All removable panels are in place and secured.

1. Allow the machine to come to ambient temperature before switching on for the first time to avoid the build up of condensation.
2. Switch on the power supply disconnecting device.
After the controller has carried out a self-test, the green *Controller Voltage* LED is lit continuously.
3. If required:
Change the display language as described in chapter 7.6.
4. Press the «ON »key.
The green *IDLE* LED lights continuously.
The drive motor runs up.



➤ Watch for any faults occurring in the first hours of operation.

➤ After the first 50 operating hours, check all electrical connections and tighten where necessary.

8 Operation

8.1 Switching on and off

Always switch the machine on with the «ON» key and off with the «OFF» key.
A power supply disconnecting device has been installed by the user.

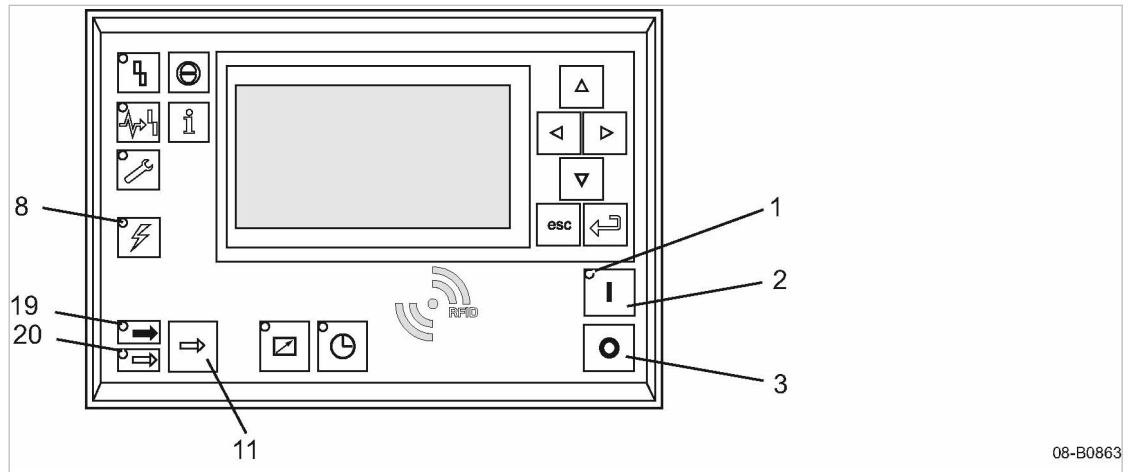

Fig. 19 Switching on and off

- | | |
|--|--------------------------|
| ① <i>Machine ON</i> LED | ⑪ «LOAD/IDLE» toggle key |
| ② «ON» key | ⑲ <i>LOAD</i> LED |
| ③ «OFF» key | ⑳ <i>IDLE</i> LED |
| ⑧ <i>Voltage applied to controller</i> LED | |

8.1.1 Switching on

Precondition No personnel are working on the machine.

No personnel inside the machine.

The removable panel of the sound enclosure and other panels are inserted and locked.

1. Switch on the power supply disconnecting device.
The *Voltage applied to controller*LED lights green.
2. Press the «ON» key.
The *ON*LED lights green.

Starting frequency

Characteristic, option	Maximum frequency of motor starts per hour
C33, START CONTROL (STC)	■ 6 times
C34, OMEGA FREQUENCY CONTROL (OFC)	■ any

Tab. 32 Starting frequency

- Adhere to maximum frequency of motor starts per hour.

Automatic restart

If a power failure occurs, the machine is **not** prevented from re-starting automatically when power is resumed.

It can re-start automatically as soon as power is restored.

- Note the instructions in the user manual supplied with SIGMA CONTROL 2 for activating and deactivating this function.

8.1.2 Switching off

1. Press the «OFF» key.

When the machine switches to IDLE (as per configuration), and during the fan run-on time, the *Machine ON* LED flashes. The *Machine ON* LED extinguishes as soon as the automatic shut-off action is completed.

2. Switch off and lock out and tag out the power supply disconnecting device.

Result The *Voltage applied to controller* LED extinguishes. The machine is switched off and disconnected from the power supply.



In rare cases, you may want to shut down the machine immediately and cannot wait until the automatic shut-down process is finished.

- Press «OFF» once again.

8.2 Switching off in an emergency and switching on again

The EMERGENCY STOP push-button is located to the right of the control panel.

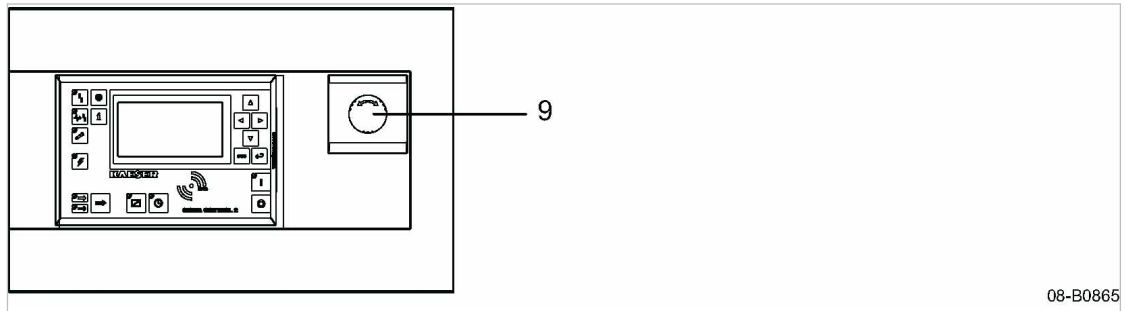

08-B0865

Fig. 20 Switching off in an emergency

- ⑨ EMERGENCY-STOP push button

Switching off

- Press the EMERGENCY STOP push button.

Result The EMERGENCY STOP push button remains latched after actuation. The compressor's pressure system is vented and the machine is prevented from automatically re-starting.

Switching on

Precondition The fault has been rectified.

1. Turn the EMERGENCY STOP push button in the direction of the arrow to unlatch it.
2. Acknowledge any existing alarm messages.

Result The machine can now be started again.

8.3 Switching on and off from a remote control center

Precondition A link to the remote control center exists.

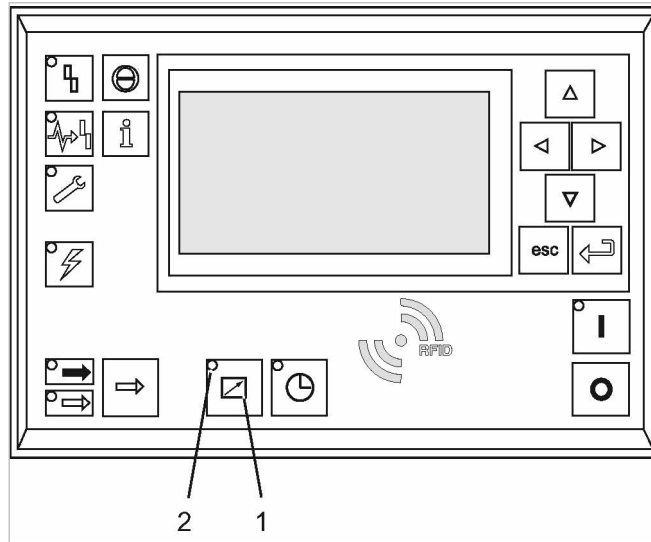

08-B1721

Fig. 21 Switching on and off from a remote control center

- ① «Remote control» key
- ② *Remote control* LED

1. Attach an easily seen notice to the machine that warns of remote operation.

⚠ WARNING

Remote control: Risk of injury caused by unexpected starting!

- Make sure that the power supply disconnecting device is switched off before commencing any work on the machine.

Tab. 33 Machine identification

2. Label the starting device in the remote control center as follows:

⚠ WARNING

Remote control: Risk of injury caused by unexpected starting!

- Before starting, make sure that no one is working on the machine and that it can be safely started.

Tab. 34 Remote control identification

3. Press the «Remote control» key.

Result The *Remote control* LED lights. The machine can be remotely controlled.

8.4 Switching on and off with the clock (timer)

Precondition The clock is programmed.

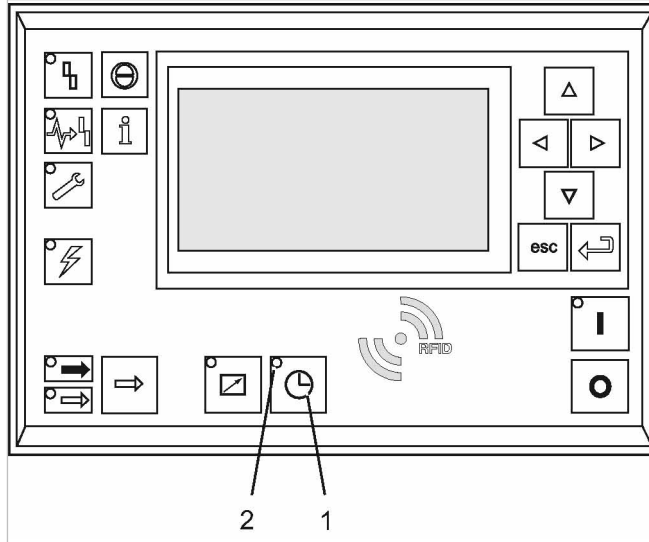

08-B1722

Fig. 22 Switching on and off with the clock (timer)

- ① «Timer control» key
- ② *Timer control* LED

1. Attach an easily seen notice warning of time-controlled operation:

⚠ WARNING

Time control: Risk of injury caused by unexpected starting!

- Make sure that the power supply disconnecting device is switched off before commencing any work on the machine.

Tab. 35 Machine identification

2. Press «Timer control».

Result The *Timer control*/LED lights. The machine is switched on and off by the clock (timer).

8.5 Option H12 Checking the ventilator fan function (sound enclosure)

NOTICE

Overheating inside the sound enclosure!

A standstill of the ventilator can result in a breakdown of the blower block or other components.

- *If the ventilator stops, immediately provide an alternative flow of cooling air through the sound enclosure.*

- Check that air is actually being blown out of the enclosure cooling air outlet, e.g. by holding a sheet of paper in front of the outlet.

Further information KAESER SERVICE will advise on suitable measures.

8.6 Interpreting operation messages

The controller will automatically display operation messages informing you about the current operational state of the machine.

Operating messages are identified with the letter B.

Further information Detailed information can be found in the SIGMA CONTROL 2 operating manual.

8.7 Acknowledging alarm and warning messages

Messages are displayed on the "new value" principle:

- Message coming: LED flashes
- Message acknowledged: LED illuminates
- Message going: LED off

or

- Message coming: LED flashes
- Message going: LED flashes
- Message acknowledged: LED off

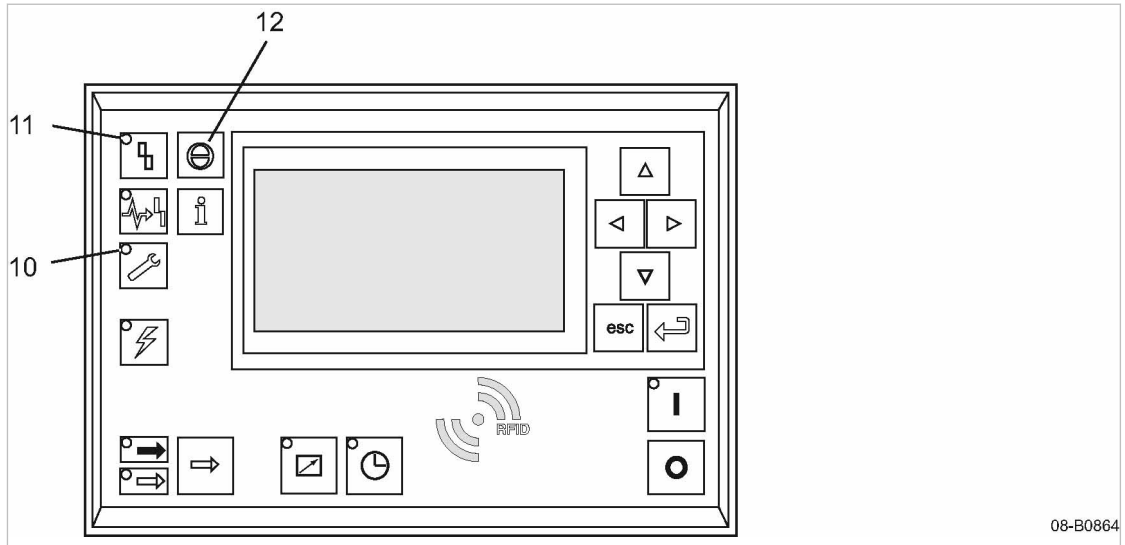

Fig. 23 Acknowledging messages

- 10 *Warning* LED (yellow)
- 11 *Alarm* LED (red)
- 12 «Acknowledge» key

Alarm message

An alarm shuts the machine down automatically. The red *Alarm* LED flashes. The system displays the appropriate message.

Precondition The fault has been rectified.

- Acknowledge the message with the «Acknowledge» key. The *Alarm* LED extinguishes. The machine is again ready for operation.



If the machine was switched off with the EMERGENCY STOP button:

- Unlatch the EMERGENCY STOP button (turn in direction of the arrow) before acknowledging the alarm message.

Further information Please refer to the SIGMA CONTROL 2 operating manual for a list of possible fault messages during operation.

Warning message

If maintenance work is to be carried out or if the warning is displayed before an alarm, the yellow *Warning* LED flashes. The system displays the appropriate message.

Precondition The danger of an alarm is passed, maintenance has been carried out.

- Acknowledge the message with the «Acknowledge» key. The *Warning* LED extinguishes.

Further information Please refer to the SIGMA CONTROL 2 operating manual for a list of possible warning messages during operation.

9 Fault Recognition and Rectification

9.1 Basic instructions

Fault messages are classified in various categories:

- Warning:
 - Warning messages *W*
- Fault (with indication):
 - Alarm messages *S*
 - System messages *Y*
 - Diagnostic messages *D*
- Other faults (without indication): See chapter 9.2

The messages valid for your machine are dependent on how the individual machine is equipped.

1. Do not attempt fault rectification measures other than those given in this manual!
2. In all other cases:
Have the fault rectified by an authorized KAESER SERVICE representative.

Further information See the operating manual of SIGMA CONTROL 2 for details regarding the various messages.

9.2 Other faults

Alarm	Possible cause	Remedy
Unusual noise when running.	Too much backlash in the timing gears.	Contact KAESER Service.
	Too much clearance in the rotor bearings.	Contact KAESER Service.
	Rotors not synchronized.	Maintain the pressure differential and speed shown in the specification. Contact KAESER Service.
Blower block runs too hot.	Pressure differential too great.	Check and correct pressure differential.
	Clogged inlet filter reducing air intake volume.	Clean the inlet filter.
	Rotor clearance too large.	Contact KAESER Service.
	Leakage due to incorrect installation of pressure-bearing components.	Contact KAESER Service.
Oil leaks from the gas drain.	Lubricating oil level too high.	Drain off lubricating oil until the correct level is reached.
Oil leaking from around the drive shaft.	Shaft seal defective.	Contact KAESER Service.
Low intake flow volume.	Rotor clearance too large because of wear.	Contact KAESER Service.
	Intake resistance too high.	Clean the inlet filter.

Alarm	Possible cause	Remedy
Black film on the oil sight glasses.	Oil not changed at the correct interval.	Change the lubricating oil. Clean or renew the sight glass.
	Insufficient lubricating oil.	Change the lubricating oil. Clean or replace the sight glass.
	Oil overheated.	Contact KAESER Service.
	Block overloaded.	Contact KAESER Service.
Water in the oil.	Condensate build-up by prolonged storage and high humidity.	Change the lubricating oil.
Safety relief valve activates.	Inadmissible operating state, operating pressure too high.	Bring the machine to a permissible operational state or shut down.

Tab. 36 Other faults and remedies

9.3 Option H12 Sound enclosure faults

Alarm	Possible cause	Remedy
Overheating inside the sound enclosure!	Fan defective or turning in the wrong direction.	Check connection. Contact an authorized KAESER service representative.
	Flow of cooling air blocked.	Check and clean cooling air apertures. Check the cooling air inlet temperature.
	Drive motor overloaded.	Check operating conditions.
	Leakage due to incorrect installation of pressure-bearing components.	Contact an authorized KAESER service representative.

Tab. 37 Faults and remedies (option H12)

10 Maintenance

10.1 Ensuring safety

Follow the safety instructions below to ensure safe maintenance of the machine.

Warning instructions are provided prior to any potentially dangerous task.



Disregard of warning instructions can result in life-threatening injuries!

Observing safety warnings

Ignoring safety warning can result in unforeseen dangers.

- Follow the instructions in chapter 3 “Safety and Responsibility”.
- Allow maintenance work to be performed by authorized personnel only!
- Ensure that no personnel are working on the machine.
- Ensure that all cover panels are closed.

Working on live components

Touching live components can result in electric shocks, burns or death.

Dangerous voltages remain in the frequency converter and intermediate circuit capacitors for some time after the power has been disconnected.

When the frequency converter is open, live components are exposed.

- Work on electrical equipment may only be carried out by authorized electricians.
- Switch off the power supply disconnecting device, lock out / tag out the device, verify the absence of any voltage.
- Before starting work on the frequency converter or intermediate circuit capacitors, wait for at least 5 minutes.
- Check that there is no voltage on floating contacts.

Working at the vacuum system

The following safety instructions relate to any work on components that could be under pressure.

- Switch off the power supply disconnecting device, lock out / tag out the device, verify the absence of any voltage.
- Vent all components and chambers under vacuum to atmospheric pressure.
- Do not open or dismantle any valves.

Working on the drive system

Touching live components can result in electric shocks, burns or death.

Touching the fan wheel or the belt drive while the machine is running can result in serious injury.

- Switch off the power supply disconnecting device, lock out / tag out the device, verify the absence of any voltage.

- Do not open any of the cover panels while the machine is switched on.
- If full protection is only provided when the machine is completely installed, then in all other phases of the machine's life-cycle temporary protective devices (e.g. covers) must be fitted, in order to guarantee that parts of the body cannot reach or be caught/sucked in by the rotary lobes.

Further information Information regarding authorized personnel can be found in chapter 3.4.2.
Information regarding dangers and their avoidance can be found in chapter 3.5.

10.2 Maintenance schedule

10.2.1 Logging maintenance work



- The maintenance intervals given are those recommended for average operating conditions.
- Maintenance tasks should be carried out more frequently where operating conditions are unfavorable (e.g. dusty atmosphere) or when the equipment is in constant use.
 - Adjust the maintenance intervals with regard to local installation and operating conditions.
- Keep a log of all maintenance and service work.
This enables the frequency of individual maintenance tasks and deviations from our recommendations to be determined.

Further information A prepared list is provided in chapter 10.15.

10.2.2 Resetting maintenance interval counters

Depending on the way a machine is equipped, sensors and/or maintenance interval counters monitor the operational state of important functional devices. Required maintenance work is shown on the SIGMA CONTROL 2.

Precondition Maintenance performed and,
Maintenance message acknowledged.

- Reset the maintenance interval counter as described in the SIGMA CONTROL 2 operating manual.

10.2.3 Regular maintenance tasks

The table below lists the required maintenance tasks.



- If operating conditions are unfavorable (e.g. dusty ambient) or if the equipment is in constant use, maintenance tasks must be carried out more frequently (shorter intervals).

- Carry out maintenance tasks in a timely manner, taking the ambient and operating conditions into consideration:

Interval	Maintenance task	See chapter
At least 24 hours after initial commissioning	Check drive belt tension.	10.5
At least 50 hours after initial commissioning	Check that all electrical connections are secure and tighten if necessary.	–
Weekly	Control cabinet: Check the filter mat.	10.3
500 hours after initial commissioning*	Change the lubricating oil.	10.8
Up to 500 h Or monthly	Check the oil level.	10.6
	Check drive belt tension.	10.5
	Check the air filter.	10.9
	Control cabinet: Clean the filter mat.	10.3
Up to 1000 h	Clean the machine.	10.11
Up to 2000 h At least once a year	Drive motor bearings with re-greasing facility: Re-grease the motor bearings.	10.12.1
Up to 3000 h At least once a year	Change the FGB 220 lubricating oil.	10.8
Up to 3000 h, At least once a year	Change the air filter.	10.9
	Control cabinet: Replace the filter mat.	10.3
Annually	Check the safety relief valve.	10.13
	Check the EMERGENCY STOP push button.	10.14
	Check that all electrical connections are secure and tighten if necessary.	–
Up to 6000 h, At least every 2 years	Change the SB 220 lubricating oil.	10.8
Up to 12000 h, At least every 4 years	Replace the drive belt.	10.5

h = operating hours

* Not applicable in the case of initial commissioning by an authorized KAESER service representative.

Tab. 38 Regular maintenance tasks

10.2.4 Regular service tasks

The table below lists necessary service tasks.

- Only an authorized KAESER service representative should carry out service work.

- Have maintenance tasks carried out in a timely manner, taking the ambient and operating conditions into account:

Interval	Service task
Up to 12000 h, At least every 4 years	Permanently greased drive motor bearings: Replace the motor bearings.
Up to 36000 h	Blower block Replace the radial shaft sealing ring.
	Drive motor bearings with re-greasing facility: Replace the motor bearings.
	Fan frequency converter: Replace the fan.
	Fan control cabinet: Replace the fan.
Up to 36000 h, At least every 8 years	(Option G1) Maintain the check valve.
	Replace the compensators
At least every 20 years	Replace safety-relevant components of the safety functions.

h = operating hours

Tab. 39 Regular service tasks

10.3 Control cabinet: Clean or replace the filter mats



The control cabinet is fitted with filter mats only if operation at the frequency converter is intended.

A filter mat is placed behind every ventilation grill. Filter mats protect the control cabinet from ingress of dirt. If the filter mats are clogged, adequate cooling of the components is no longer ensured. In such a case, clean or replace the filter mats.

Material Warm water with household detergent
Spare part (as required)

Precondition The power supply disconnecting device is switched off, lock out and tag out the device, the absence of any voltage has been verified.



10-B0908

Fig. 24 Control cabinet ventilation

- ① Ventilation grill
- ② Filter mat

1. Carefully remove the ventilation grill and take out the filter mat.
2. Beat the mat or use a vacuum cleaner to remove loose dirt. If necessary, wash with lukewarm water and household detergent.
3. Replace the filter mat if cleaning is not possible or if the change interval has expired.
4. Lay the filter mat in the frame and latch in the ventilation grill.

10.4 Option H12 Sound enclosure

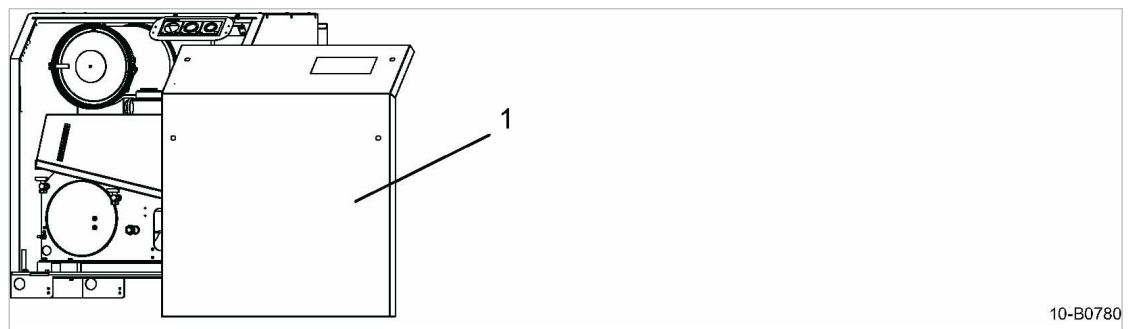

10-B0780

Fig. 25 Sound enclosure

- ① Removable panel

➤ Remove the panel ① for maintenance work.



Latches are released by a key supplied with the machine.

10.5 Drive belt maintenance

Material Spare parts (if required)

Precondition The power supply disconnecting device is switched off, lock out and tag out the device, the absence of any voltage has been verified.
The machine has cooled down.

⚠ WARNING

Touching the moving drive belt may result in severe bruising or even loss of limb or extremities.

➤ *Switch off and lock out/tag out the power supply disconnecting device and verify the absence of voltage.*

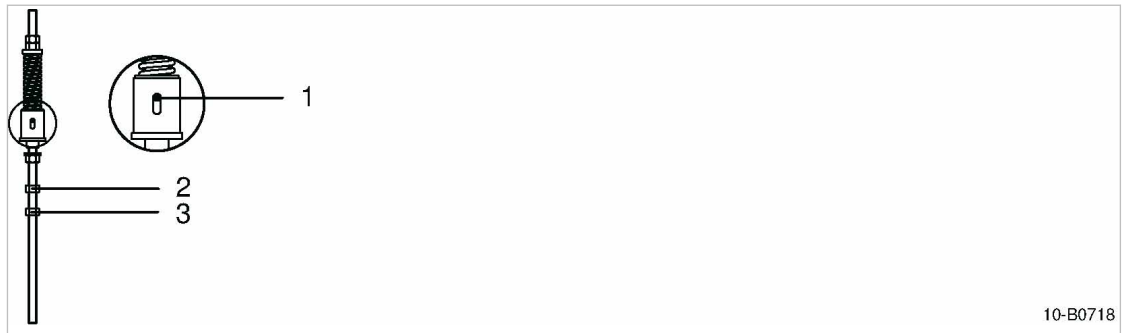

10-B0718

Fig. 26 Drive belt maintenance

- ① Marker pin (shown as: belt tensioning required)
- ② Locking nut
- ③ Adjusting nut

Checking belt tension and adjustment

The tensioning device uses spring force to apply correct tension to the belt.

Adjust the tension before the marker pin reaches the **top** end of the elongated hole.

1. Loosen the locking nut ②.
2. Use the adjusting nut ③ to adjust spring tension until the marker pin reaches the lower end of the elongated hole.
3. Tighten the locking nut ②.

Visually check for damages.

1. **⚠ CAUTION** *Danger of pinching between belt and pulley!*
➤ *Work carefully.*
2. Turn the pulley by hand so that the entire belt can be inspected for damage.
3. In case of damage: Replace the drive belt immediately.



When individual belts fail in multiple-groove drives, all belts must be replaced.

Changing the belt.

1. Remove the belt guard.
2. Loosen the locking nut (2).
3. Turn the adjusting nut (3) to loosen the tension on the belts until they can be removed from the pulley.
4. Install the new set of belts and use the adjusting nut (3) to adjust the tension until the marker pin reaches the lower end of the elongated hole.
5. Tighten the locking nut (2).
6. Replace the belt guard.
7. Check the tension after the new belt has been in operation for 50 hours.

10.6 Checking the oil level

The true oil level can be seen in the oil sight glass only when the machine is stopped.



The gear-end and drive-end oil chambers are not connected.

⚠ WARNING

Danger of burns from hot components!

➤ *Wear long-sleeved clothing and protective gloves.*

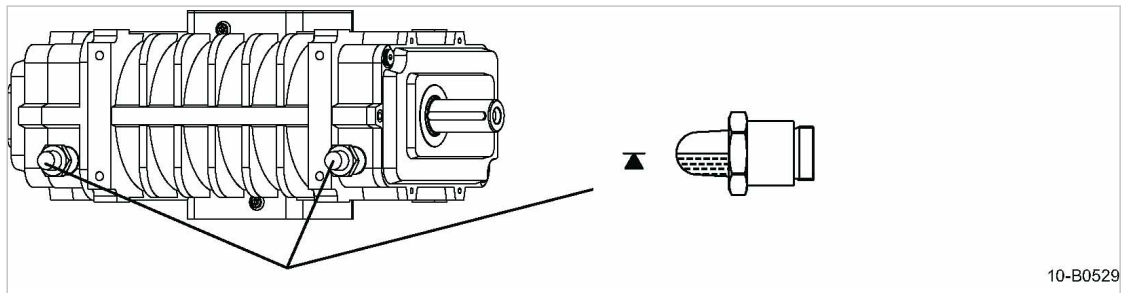

Fig. 27 Checking the oil level

1. Check the oil level in the sight glasses on both ends of the block.
2. Replenish as soon as the level falls 0.3 in. below the center of the sight glass.

10.7 Replenishing lubricating oil

Labels giving the oil type for replenishing can be found on the blower block and belt guard.



Prior to any work requiring an opening of the vacuum system, the machine must be fully vented to atmospheric pressure.

Precondition The power supply disconnecting device is switched off
The disconnecting device is locked in the off position.
The oil level has settled.

⚠ WARNING

Danger of burns from hot components and oil!

- *Wear long-sleeved clothing and protective gloves.*

NOTICE

Unsuitable oil can damage the block.

- *Never mix different types of oil.*
- *Never top off with a different type of oil than that already used in the blower block.*

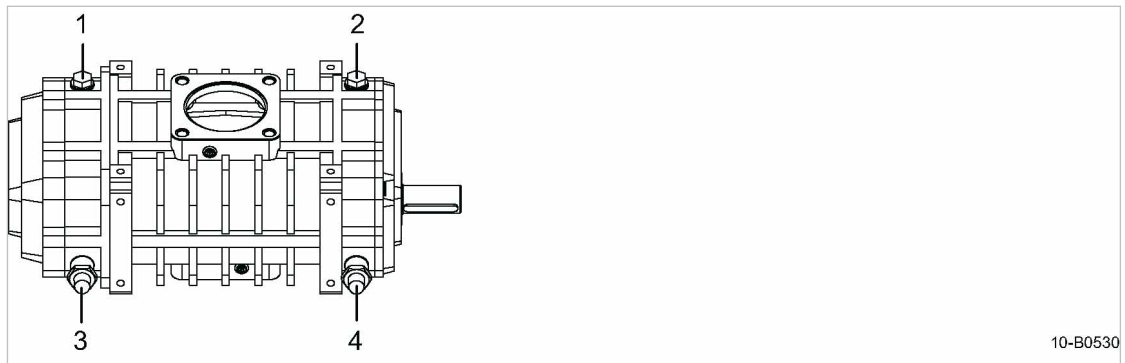

Fig. 28 Replenishing lubricating oil

- | | |
|---|---|
| <p>① Plug
(oil filling port, control end)</p> <p>② Plug
(oil filling port, drive end)</p> | <p>③ Control-end oil sight glass</p> <p>④ Drive-end oil sight glass</p> |
|---|---|

1. Slowly remove the plug ① and/or ②.
2. Top off until the level is at the marking on the sight glass ③ and/or ④.
3. Screw in the plugs.
4. Visually check for leaks.

10.8 Changing the oil



Prior to any work requiring an opening of the vacuum system, the machine must be fully vented to atmospheric pressure.

The oil should be changed with the block temperature at 130°F to ensure the oil flows freely.

Drain the oil thoroughly from the blower block:

- Control end
- Drive end

Material Lubricating oil
Oil receptacle

Precondition The power supply disconnecting device is switched off,
The device is locked off,
A check has been made that no voltage is present.

⚠ WARNING

Danger of burns from hot components and oil!

➤ *Wear long-sleeved clothing and protective gloves.*

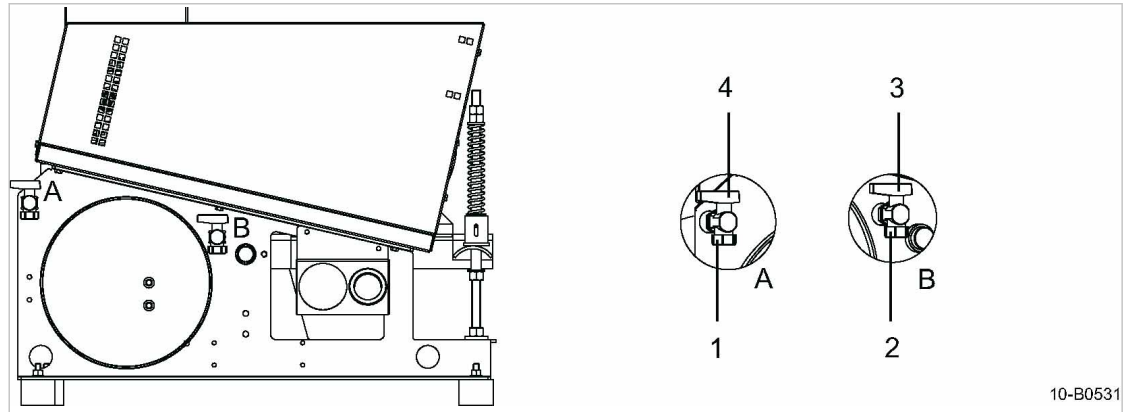

Fig. 29 Changing the oil

- | | | | |
|---|-------------|---|---------------|
| Ⓐ | Drive end | ② | Cap |
| Ⓑ | Control end | ③ | Oil drain tap |
| ① | Cap | ④ | Oil drain tap |

Draining the oil

1. Prepare an oil receptacle.
2. Open the filler plugs at the oil inlet of the blower block ① and ② (Fig. 28).
3. Take off the caps ① and ② and open the oil drain taps ③ and ④.
4. Drain the lubricating oil.



Dispose of the old oil in accordance with local environmental protection regulations.

Filling with fresh oil

1. Fill with fresh oil.
2. Allow the oil drain taps to remain open until fresh oil begins to run out (bleeding the oil drain lines).
3. Close the oil drain taps ③ and ④.
4. Check the oil level in both sight glasses (Fig. 28) and top off as necessary.
5. Screw on the caps ① and ②.
6. Replace and tighten the plugs of the oil inlets at the blower block.
7. Visually check for leaks.

10.9 Air filter maintenance

The air filter protects the vacuum system contained in the scope of delivery from ingress of dirt.

NOTICE

*Machine damage caused by unsuitable air filter!
Dirt can enter the vacuum system and cause damage to the machine.*

➤ *Use only genuine KAESER replacement air filters.*



The air filter cannot be cleaned.

10.10 Air filter maintenance

Prior to any work requiring an opening of the vacuum system, the machine must be fully vented to atmospheric pressure.

Material Spare parts

Precondition The power supply disconnecting device is switched off, the device is locked off, the absence of any voltage has been verified, the machine has cooled down.

⚠ WARNING

Danger of burns from hot components!

➤ *Wear long-sleeved clothing and gloves.*



10-B0750

Fig. 30 Changing the air filter

- ① Cover
- ② Inlet silencer
- ③ Air filter

1. Open the snap fastener on the inlet silencer cover.
2. Take off the cover ①.
3. Loosen the Velcro strip and remove the air filter ③.
4. Clean all parts and sealing surfaces.
5. Place the new filter around the perforated inlet port and secure with the Velcro strip.
6. Attach the cover to the inlet silencer.

10.11 Machine cleaning

Regularly clean the machine. This ensures reliable cooling of the machine. The frequency is mainly dependent on local operating conditions.



Clogged machines are indicative of unfavorable ambient conditions. Such ambient conditions clog the cooling air ducts in the machine's interior and the motors resulting in increased wear and tear.

Material Brush and/or compressed air
Protective gloves
Face mask and safety goggles (if required)
Vacuum cleaner

Precondition The power supply disconnecting device is switched off,
the device is locked off,
the absence of any voltage has been verified.
The machine has cooled down.

1. Open the sound enclosure (Option H12).
Dismantle panels in order to clean the cooling air ducts of the drive motor.
2. Dry brush the machine or blow off with compressed air.
3. Vacuum off dirt.
4. Close sound enclosure (Option H12).
Replace and lock panels.



The machine cannot be cleaned?

- Have severe clogging removed by an authorized KAESER service representative.

10.12 Motor maintenance

Motor maintenance depends on the type of motor.

Material Grease gun with bearing grease UNIREX N3
Cleaning cloth

10.12.1 Drive motor bearings with re-greasing facility



Use only the high temperature grease UNIREX N3 for the motor bearings. Damage to bearings caused by the use of other brands of grease is excluded from the warranty.

The required quantity of grease is stated on the motor maintenance plate.

Precondition The motor is running.

1. **⚠ WARNING** *Noise during machine operation without sound enclosure or noise due to opened removable access panel of the sound enclosure (Option H12)! Hearing may be damaged.*
 - *Always wear ear protection.*
2. **⚠ WARNING** *Danger of burns from hot components!*
 - *Wear long-sleeved clothing and protective gloves.*
 - *Work with caution.*

3. **NOTICE** *Drive motor damage due to incorrect re-greasing!*
If the motor is switched off, the new bearing grease is distributed incorrectly and pressed unused into the old grease tank.
 - Re-grease the bearings only with the motor running.
4. The motor bearings must be replaced in the course of regular maintenance by an authorized KAESER service representative.

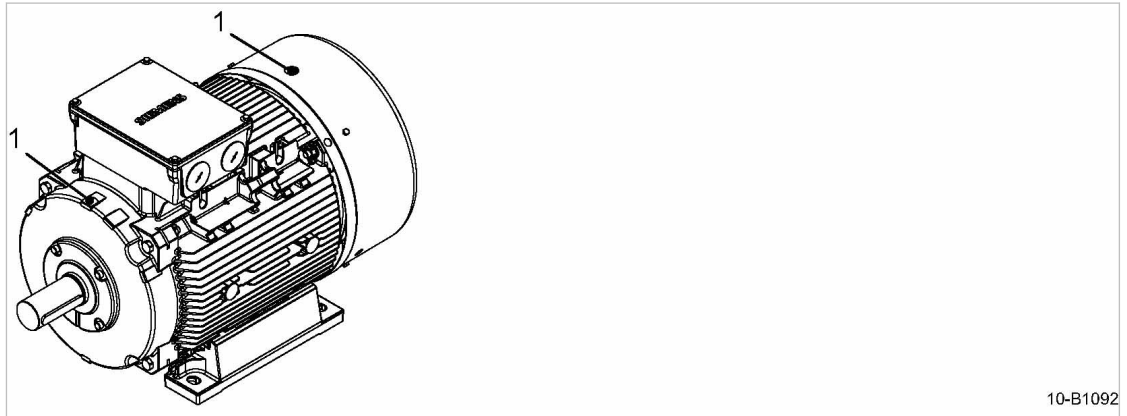

Fig. 31 Drive motor maintenance

① Grease fitting

1. Clean the fittings ① with a cloth before greasing.
2. Grease both bearings with a grease gun.

Further information The re-greasing interval and required quantity of grease are provided in chapter 2.4. For further information regarding the motor, please consult the motor manual.

10.12.2 Permanently greased drive motor bearings

The motor bearings are permanently lubricated. Re-greasing is not necessary.

- The motor bearings must be replaced in the course of regular service calls by an authorized KAESER service representative.

Further information For further information regarding the motor, please consult the motor manual.

10.12.3 Option H12 Fan motor

The motor bearings are permanently lubricated. Re-greasing is not necessary.

- The fan must be replaced in the course of regular service calls by an authorized KAESER service representative.

10.13 Testing the safety relief valve

Precondition The machine is switched off.
The machine is fully vented to atmosphere.

- Check the safety relief valve for free movement.
The valve opens as soon as maximum working pressure is exceeded.

- Never operate the machine without a correctly functioning safety relief valve.
- Do **not** adjust the safety relief valve.
- Replace a defective safety relief valve.

10.14 Testing the EMERGENCY STOP push button

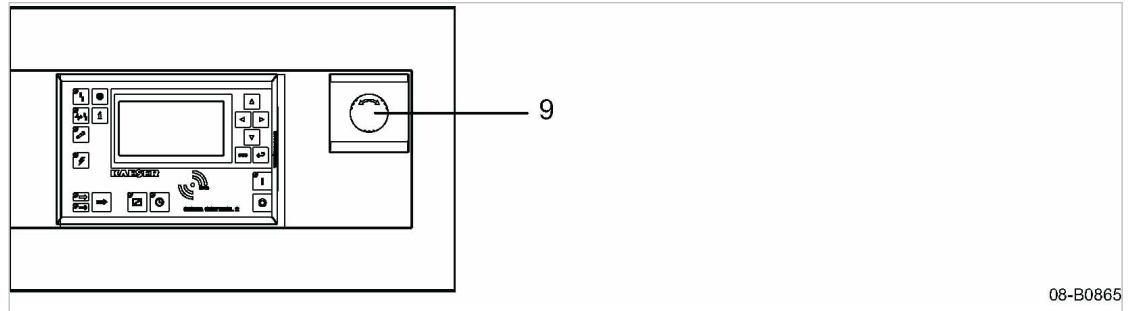

Fig. 32 Testing the EMERGENCY STOP push button

⑨ EMERGENCY STOP push button

Precondition The drive motor is running.

1. Press the EMERGENCY STOP push button.
The drive motor stops, the pressure system is vented and the machine is prevented from automatic restarting.



The drive motor does not stop?

The safety function of the EMERGENCY STOP push button is no longer ensured.

- Immediately shut down the machine and contact an authorized KAESER service representative.

2. Turn the EMERGENCY STOP push button in the direction of the arrow to unlatch it.
3. Acknowledge the fault message.

11 Spares, Operating Materials, Service

11.1 Note the nameplate

The nameplate contains all information to identify your machine. This information is essential to us in order to provide you with optimal service.

- Please give the information from the nameplate with every inquiry and order for spares.

11.2 Ordering spares and operating fluids/materials

KAESER consumable parts and operating fluids/materials operating materials are original KAESER products. They are specifically selected for use in KAESER machines.

⚠ WARNING

There is risk of personal injury or damage to the machine resulting from the use of unsuitable spare parts or operating fluids/materials.

Non-Kaeser parts and operating fluids/materials may be unsuitable or of poor quality and can damage the machine or impair its proper function.

Damage to the machine can also result in personal injury.

- *Use only original KAESER parts and operating fluids/materials.*
- *Have authorized KAESER SERVICE representative carry out regular repair and maintenance.*

Machine

Name	Number
Drive belt	1800
Filter mat (control cabinet)	1150
Air filter	1250
Lubricating oil	1600

Tab. 41 Consumable parts

11.3 Replacement parts for service and repair

Use these spare parts lists to plan your material requirement according to operating conditions and to order the required spare parts.



- Make sure that any service or repair tasks not described in this manual are carried out by an authorized KAESER service representative.

11.3.1 Option C33, START CONTROL (STC)

Service-Kit
(Option)

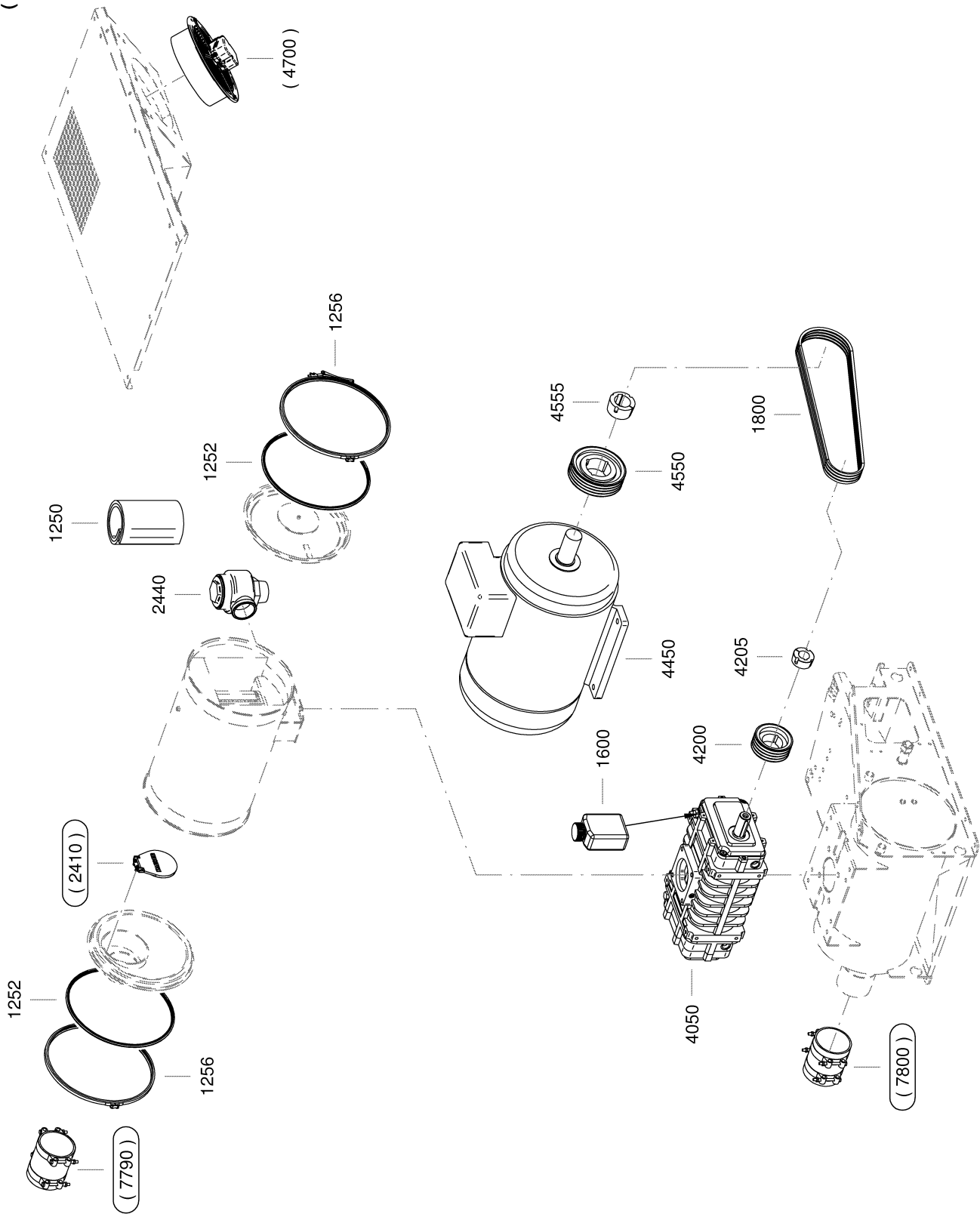

SEG-5552_01

Legend		KAESER
	DBC vac	SEL-3930_01 E
Item	Description	Option
1250	Air filter insert	
1252	Inlet silencer gasket	
1256	Canopy fastener	
1600	OMEGA FLUID	
1800	Drive belt	
2410	Check valve	X
2440	Vacuum limiting valve	
4050	OMEGA blower block	
4200	Airend pulley	
4205	Tapered bushing, airend	
4450	Drive motor	
4550	Drive motor pulley	
4555	Tapered bushing, drive motor	
4700	Fan unit	X
7790	Compensator, air inlet	X
7800	Compensator, air outlet	X

11.3.2 Option C34, OMEGA FREQUENCY CONTROL (OFC)

Service-Kit
(Option)

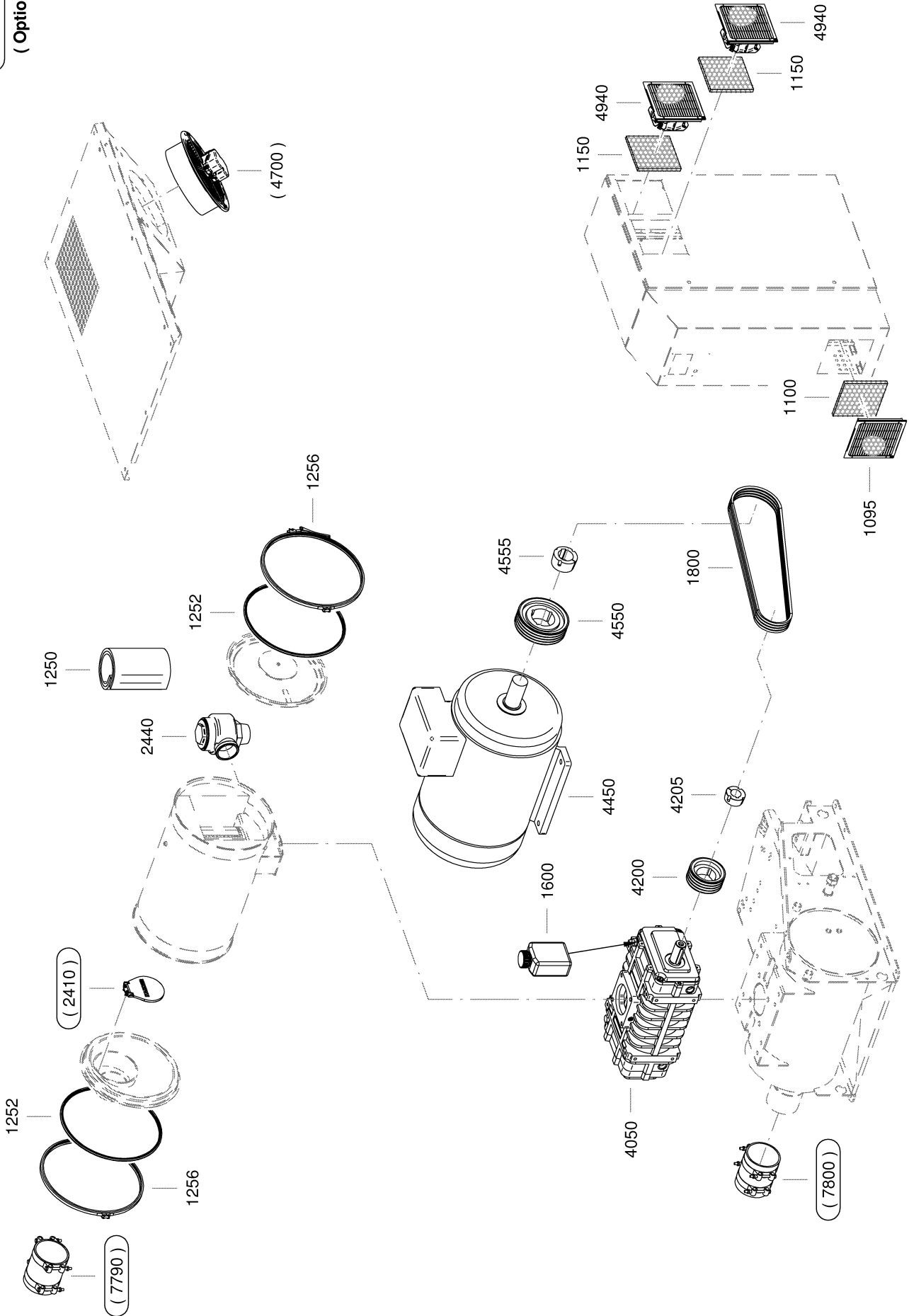

SEG-5553_01

Legend		KAESER
DBC OFC vac		SEL-3931_01 E
Item	Description	Option
1095	Control cabinet breather	
1100	Filter mat, control cabinet	
1150	Filter mat, converter cabinet	
1250	Air filter insert	
1252	Inlet silencer gasket	
1256	Canopy fastener	
1600	OMEGA FLUID	
1800	Drive belt	
2410	Check valve	X
2440	Vacuum limiting valve	
4050	OMEGA blower block	
4200	Airend pulley	
4205	Tapered bushing, airend	
4450	Drive motor	
4550	Drive motor pulley	
4555	Tapered bushing, drive motor	
4700	Fan unit	X
4940	Control cabinet fan SFC	
7790	Compensator, air inlet	X
7800	Compensator, air outlet	X
<p>Please quote the part number and serial number of the machine together with the item number and the description of the part when ordering.</p> <p>Before and during all work, be sure to read and follow the safety and service instructions in the machine's service manual!</p>		
<p>*) see cooling oil recommendations</p>		

11.4 KAESER AIR SERVICE

KAESER AIR SERVICE offers:

- authorized KAESER service representatives with KAESER factory training,
- increased operational reliability ensured by preventive maintenance,
- energy savings achieved by avoidance of pressure losses,
- optimum conditions for operation of the compressed air system,
- the security of genuine KAESER spare parts,
- increased legal certainty as all regulations are kept to.

➤ Why not sign a KAESER AIR SERVICE maintenance agreement!

Result Your advantage:
lower costs and higher compressed air availability.

11.5 Completing the contamination declaration

Every company (user) is responsible for the health and safety of its employees. This extends to personnel who carry out servicing work at the user or service contractor.

A Declaration of Contamination must be completed and signed whenever maintenance or repair work is to be carried out on the machine.

1. Contact KAESER SERVICE and request the contamination declaration form.
2. Attach a copy of the Declaration of Contamination to the **outside** of the packing.

12 Decommissioning, Storage and Transport

12.1 Decommissioning

Decommissioning is necessary, for example, under the following circumstances:

- The machine is temporarily not needed,
- The machine is to be moved to another location,
- The machine is to be scrapped.

Temporary decommissioning

Precondition The machine can be started at regular intervals.

- Run the machine once a week for at least 30 minutes at operating temperature to ensure corrosion protection.

Long-term decommissioning

Precondition The power supply disconnecting device is switched off, the device is locked off, the absence of voltage has been verified, the machine is fully vented.

1. Allow the machine to completely cool down.
2. Disconnect all air and electrical connections.
3. Relax the drive belt.
4. Spray the machine inside and out with a preservative to prevent corrosion.
5. Store the machine in a dry, frost-proof room.

Further information Details of preservatives can be found in chapter 12.4.

12.2 Packing

A wooden crate is required for overland transport to protect the machine from mechanical damage. Other measures must be taken for the transport of machines by sea or air. Please contact an authorized KAESER SERVICE for more information.

Material Protective plastic sheeting
Wooden transport crate

Precondition The machine is decommissioned.
The machine is dry and cooled down.

1. Wrap the machine fully in plastic sheeting.
2. Protect the machine in a wooden crate against mechanical damages.

12.3 Transport

12.3.1 Safety

Weight and center of gravity determine the most suitable method of transportation. Both are specified in the dimensional drawings in chapter 13.2.

Precondition Transport only by pallet truck, forklift truck or lifting gear by personnel trained in the safe transportation of loads.

- Ensure the danger area is clear of personnel.

12.3.2 Transport machine with a pallet truck or forklift truck

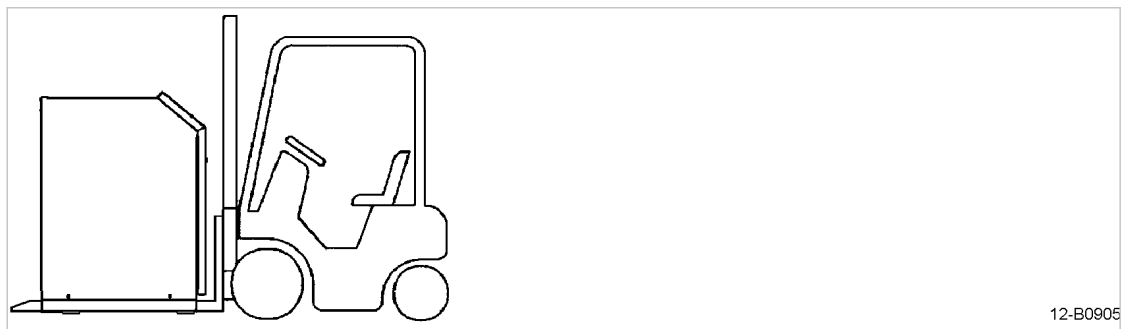

Fig. 33 Transport

1. Remove the cover plate from the sound enclosure's frame (see chapter 6.7).
2. Take note of the center of gravity.
3. Drive the pallet truck fully or forklift truck beneath the entire machine and transport with care.

12.4 Storage

Moisture can lead to corrosion, particularly on the surfaces of the blower block. The storage temperature must not fall below -86°F .



Should you have any questions concerning the correct storage and recommissioning procedure, KAESER will be glad to assist you.

⚠ CAUTION

*Rotating lobes!
Danger of crushing or severing limbs.*

- *Do not reach into the interior of the blower block.*
- *If full protection is only provided when the machine is completely installed, then in all other phases of the machine's life-cycle temporary protective devices (e.g. covers) must be fitted, in order to guarantee that parts of the body cannot reach or be caught/sucked in by the rotary lobes.*

NOTICE

Moisture and frost can damage the machine.

- *Prevent the ingress of moisture and formation of condensation.*

- Store the machine in a dry, frost-proof room.
- Seal off the inlet and discharge ports to prevent the ingress of dirt.
- Every month, manually turn the motor shaft by approx. 30°.
- Change the lubricating oil annually.

After long-term storage

- Observe the procedures for assembly and initial commissioning.

12.5 Disposal

When disposing of a machine, drain out all liquids and remove old filters.

Precondition The machine is decommissioned.

1. Completely drain the oil from the machine.
2. Remove old filters.
3. Hand the machine over to an authorized disposal expert.



- Components contaminated with oil must be disposed of in accordance with local environmental protection regulations.

13 Annex

13.1 Pipeline and instrument flow diagram (P+I diagram)

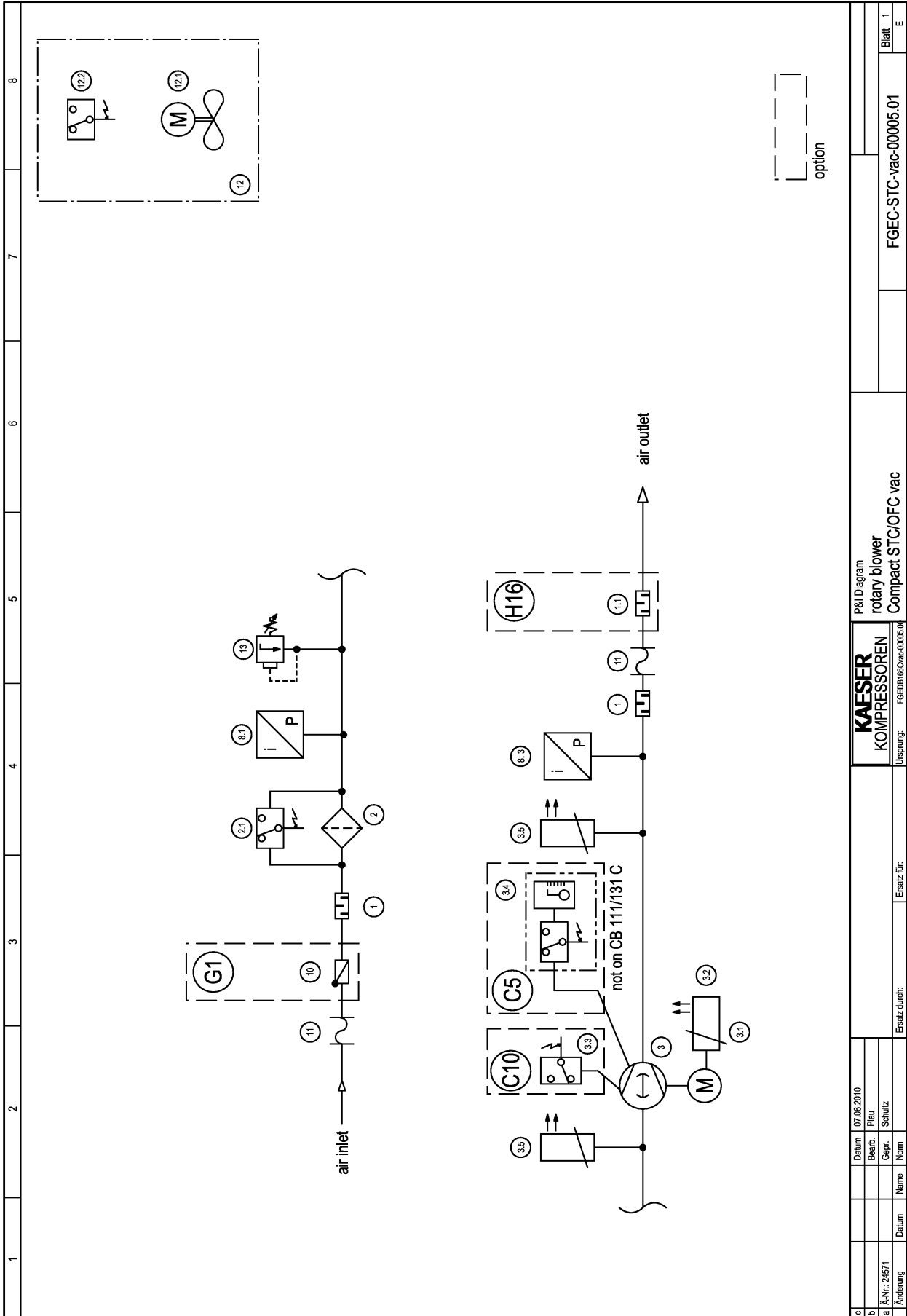

Date		07.06.2010	P&I Diagram	
Bearb.		Pleu	rotary blower	
Gepr.		Schulz	Compact STC/OFC vac	
Name			Ersatz für:	
Datum			Ersatz durch:	
Änderung			Ursprung: FGECB166Cas-00005.01	
			FGEC-STC-vac-00005.01	
			Blatt 1	
			E	

1	2	3	4	5	6	7	8
1	silencer				option		
1.1	blow-off silencer				C5	oil level monitor (not on CB 111/131 C)	
2	air filter				C10	speed monitor	
2.1	differential pressure switch				G1	check plate	
3	blower block				H16	blow-off silencer	
3.1	drive motor						
3.2	PTC-sensor						
3.3	speed monitor						
3.4	oil-level sensor, switching						
3.5	PT100-sensor						
8.1	pressure transducer - system pressure						
8.3	pressure transducer - air outlet						
10	check plate						
11	compensator						
12	sound enclosure						
12.1	fan motor						
12.2	thermostat						
13	inlet valve						
c	Datum	07.06.2010					
b	Bearb.	Pleu					
a	Gepr.	Schulz					
Änderung	Name						
	Datum						
	Ersatz durch:						
	Ersatz für:						
				P&I Diagram rotary blower Compact STC/OFC vac		FGEC-STC-vac-00005.01	
						Blatt 2 E	

13.2 Dimensional drawing

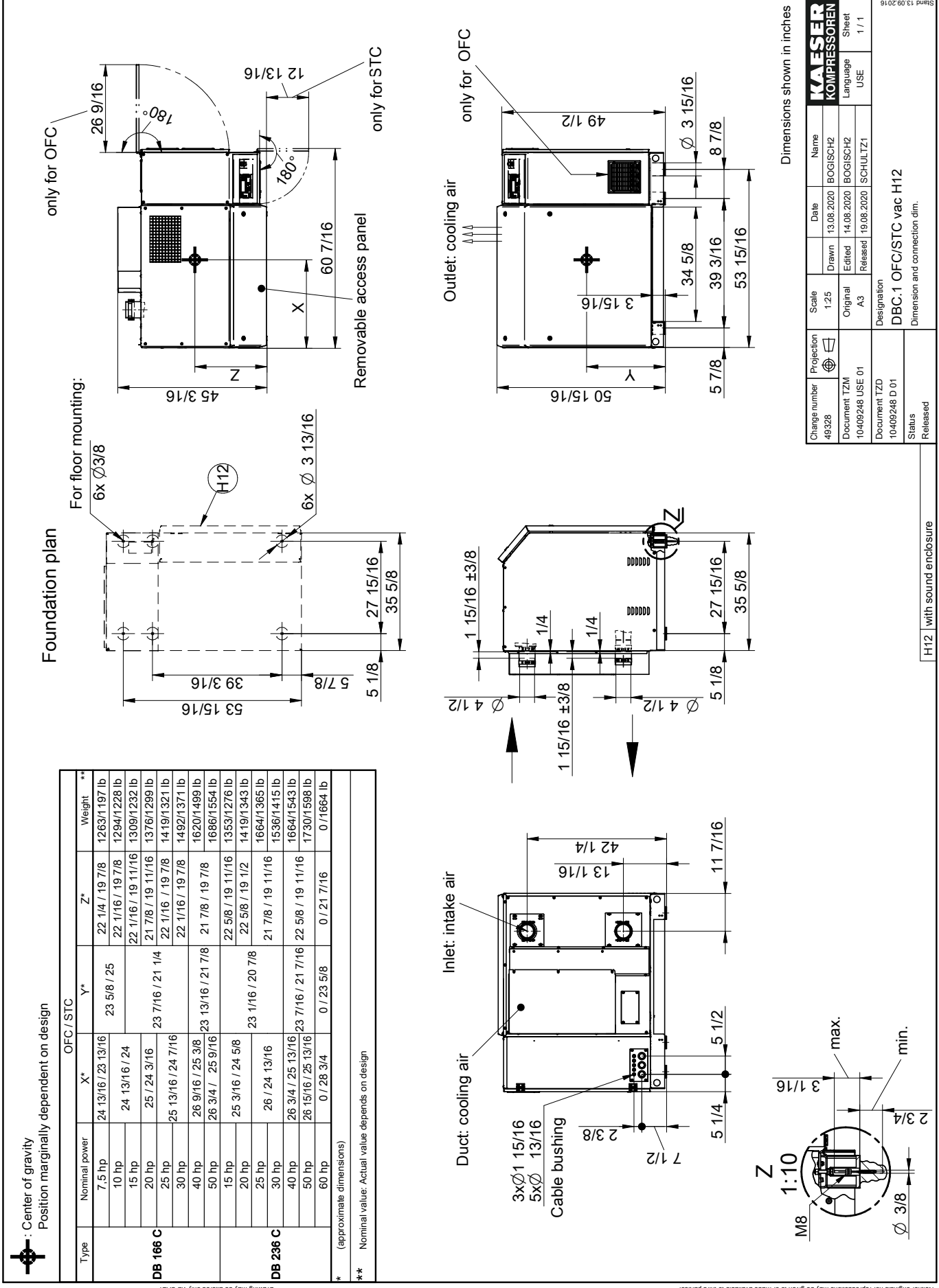

Change number	49328	Projection	1:25	Scale	1:25	Name	BOGISCHE
Document TZM	10409248 USE 01	Original	A3	Drawn	13.08.2020	Date	13.08.2020
Document TZD	10409248 D 01	Released	A3	Edited	14.08.2020	Released	19.08.2020
Status	Released	Designation	DBC.1 OFC/STC vac H12				
Released		Dimension and connection dim.					

Language	USE	Sheet	1 / 1
----------	-----	-------	-------

Center of gravity
Position marginally dependent on design

OFC / STC

Type	Nominal power	X*	Y*	Z*	Weight**
DB 166 C	7.5 hp	24 13/16 / 23 13/16	23 5/8 / 25	22 1/4 / 19 7/8	1263/1197 lb
	10 hp	24 13/16 / 24		22 1/16 / 19 7/8	1294/1228 lb
	15 hp	25 / 24 3/16	23 7/16 / 21 1/4	21 7/8 / 19 11/16	1309/1232 lb
	20 hp	25 13/16 / 24 7/16		22 1/16 / 19 7/8	1376/1289 lb
	25 hp	26 9/16 / 25 3/8	23 13/16 / 21 7/8	22 1/16 / 19 7/8	1419/1321 lb
	30 hp	26 3/4 / 25 9/16		21 7/8 / 19 7/8	1492/1371 lb
DB 236 C	15 hp	25 3/16 / 24 5/8		22 5/8 / 19 11/16	1620/1499 lb
	20 hp	26 / 24 13/16	23 1/16 / 20 7/8	22 5/8 / 19 11/16	1353/1276 lb
	25 hp	26 3/4 / 25 13/16		21 7/8 / 19 11/16	1419/1343 lb
	30 hp	26 15/16 / 25 13/16		22 5/8 / 19 11/16	1664/1365 lb
	40 hp	0 / 28 3/4	0 / 23 5/8	22 5/8 / 19 11/16	1536/1415 lb
	60 hp			0 / 21 7/16	1664/1543 lb

(approximate dimensions)

** Nominal value: Actual value depends on design

Drawings remain our exclusive property. Neither originals nor reproductions may be given to or made available to third parties. Copies or any other reproductions, including storage, treatment and distribution by use of electronic systems is not allowed for any other than the agreed upon purpose. This file shall only be used for the agreed upon purpose.

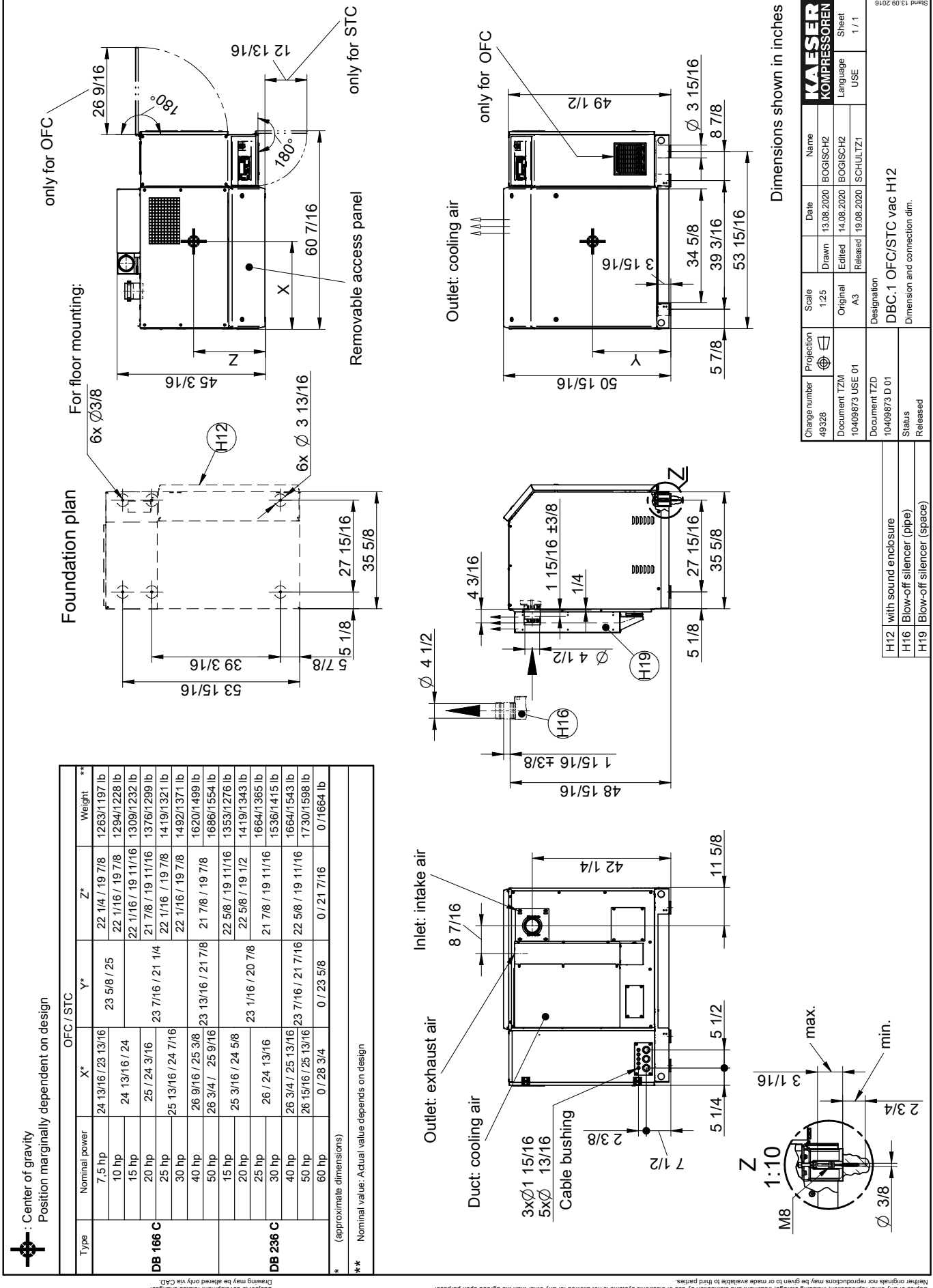

Type	OFC / STC				
	Nominal power	X*	Y*	Z*	Weight **
DB 166 C	7.5 hp	24 13/16 / 23 13/16	23 5/8 / 25	22 1/4 / 19 7/8	1263/1197 lb
	10 hp	24 13/16 / 24		22 1/16 / 19 7/8	1294/1228 lb
	15 hp	25 / 24 3/16		22 1/16 / 19 11/16	1309/1232 lb
	20 hp	25 13/16 / 24 7/16	23 7/16 / 21 1/4	21 7/8 / 19 11/16	1376/1299 lb
	30 hp	26 9/16 / 25 3/8	23 13/16 / 21 7/8	22 1/16 / 19 7/8	1419/1321 lb
DB 236 C	40 hp	26 3/4 / 25 13/16	23 13/16 / 21 7/8	21 7/8 / 19 7/8	1620/1499 lb
	50 hp	26 3/4 / 25 9/16		22 5/8 / 19 11/16	1686/1554 lb
	15 hp	25 3/16 / 24 5/8		22 5/8 / 19 1/2	1353/1276 lb
	20 hp	26 / 24 13/16	23 1/16 / 20 7/8	21 7/8 / 19 11/16	1419/1343 lb
	25 hp	26 3/4 / 25 13/16		21 7/8 / 19 11/16	1664/1365 lb
30 hp	26 15/16 / 25 13/16	23 7/16 / 21 7/16	22 5/8 / 19 11/16	1536/1415 lb	
40 hp	0 / 28 3/4	0 / 23 5/8	0 / 21 7/16	1664/1543 lb	
50 hp				1730/1598 lb	
60 hp				0 / 1664 lb	

* (approximate dimensions)
** Nominal value; Actual value depends on design

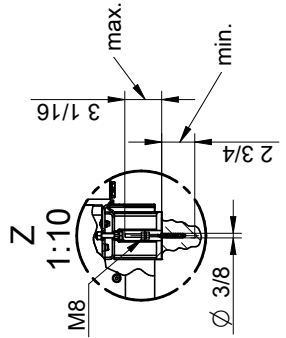

13.3 Sound emission

The values for sound pressure levels and sound power levels are provided in the tables below:
Each table discusses one type.

The values applicable to the machine result from the combination of the blower block speed and the differential pressure.

If the texts of the tables are not provided in the chosen language, a translation can be found here.

	Table legend
a)	Model
b)	Without sound enclosure
c)	With sound enclosure
d)	Blower block speed
e)	Pressure differential
f)	Sound pressure level
g)	Sound power level

Tab. 42 Sound emission - legend

d) block speed [min ⁻¹]	a) DB166C		b) without sound enclosure		c) with sound enclosure	
	e) pressure differential		f) sound level	g) sound power level	f) sound level	g) sound power level
	[mbar]	[psi]	[dB(A)]	[dB(A)]	[dB(A)]	[dB(A)]
			± 3 dB(A)	± 3 dB(A)	± 3 dB(A)	± 3 dB(A)
2420	200	3	80	96	72	88
2420	300	4	80	96	72	88
2420	400	6	81	96	72	88
2420	490	7	82	97	73	89
2570	200	3	81	96	72	88
2570	300	4	81	96	72	88
2570	400	6	82	97	72	88
2570	500	7	83	98	73	89
2760	200	3	82	97	72	88
2760	300	4	82	97	72	88
2760	400	6	83	98	72	88
2760	500	7	84	99	73	89
2920	200	3	83	98	72	88
2920	300	4	83	98	72	88
2920	400	6	84	99	72	88
2920	500	7	85	100	73	89
3100	200	3	84	99	72	88
3100	300	4	84	99	72	88
3100	400	6	85	100	72	88
3100	500	7	86	101	72	88
3320	200	3	85	100	72	88
3320	300	4	85	100	72	88
3320	400	6	86	101	72	88
3320	500	7	87	102	72	88
3560	200	3	86	102	72	88
3560	300	4	86	102	72	88
3560	400	6	87	103	72	88
3560	500	7	88	104	73	89
3780	200	3	88	103	73	89
3780	300	4	88	103	73	89
3780	400	6	89	104	73	89
3780	500	7	90	105	73	89
4000	200	3	89	105	73	89
4000	300	4	89	105	73	89
4000	400	6	90	105	73	89
4000	500	7	91	106	73	89
4220	200	3	91	106	73	89
4220	300	4	91	106	73	89
4220	400	6	91	107	73	89
4220	500	7	92	108	73	89
4450	200	3	92	108	73	89
4450	300	4	92	108	73	89
4450	400	6	93	108	73	89
4450	500	7	94	109	73	89
4720	200	3	94	110	73	89
4720	300	4	94	110	73	89
4720	400	6	94	110	73	89
4720	500	7	95	111	73	89

d) block speed [min ⁻¹]	a) DB236C		b) without sound enclosure		c) with sound enclosure	
	e) pressure differential		f) sound level	g) sound power level	f) sound level	g) sound power level
	[mbar]	[psi]	[dB(A)]	[dB(A)]	[dB(A)]	[dB(A)]
			± 3 dB(A)	± 3 dB(A)	± 3 dB(A)	± 3 dB(A)
2420	200	3	80	96	72	88
2420	300	4	80	96	72	88
2420	400	6	81	97	72	88
2420	500	7	81	96	74	90
2570	200	3	81	96	72	88
2570	300	4	82	97	72	88
2570	400	6	82	97	72	88
2570	500	7	82	97	74	90
2760	200	3	83	98	72	88
2760	300	4	83	98	72	88
2760	400	6	84	99	72	88
2760	500	7	84	99	74	90
2920	200	3	85	100	72	88
2920	300	4	85	100	72	88
2920	400	6	86	102	72	88
2920	500	7	88	103	74	90
3100	200	3	89	105	72	88
3100	300	4	91	106	72	88
3100	400	6	82	98	72	88
3100	500	7	83	98	72	88
3320	200	3	83	98	72	88
3320	300	4	84	99	72	88
3320	400	6	84	99	72	88
3320	500	7	85	100	72	88
3560	200	3	85	100	72	88
3560	300	4	86	101	72	88
3560	400	6	86	102	72	88
3560	500	7	88	103	73	89
3780	200	3	89	105	73	89
3780	300	4	91	106	73	89
3780	400	6	93	108	73	89
3780	500	7	86	101	73	89
4000	200	3	87	102	73	89
4000	300	4	87	103	73	89
4000	400	6	88	104	73	89
4000	500	7	89	104	73	89
4220	200	3	90	106	73	89
4220	300	4	93	108	73	89
4220	400	6	90	105	73	89
4220	500	7	91	107	73	89
4450	200	3	92	107	73	89
4450	300	4	94	109	73	89
4450	400	6	93	108	73	89
4450	500	7	95	110	73	89

13.4 Electrical diagrams**13.4.1 Option C33, START CONTROL (STC)**

1	2	3	4	5	6	7	8																																
<div style="border: 1px solid black; padding: 10px; margin: 0 auto; width: 80%;"> <p style="font-size: 1.2em; margin: 0;">Wiring Diagram</p> <p style="font-size: 1.2em; margin: 0;">Blower with wye-delta start</p> <p style="margin: 0;">+ SIGMA CONTROL 2 (SC2)</p> <table style="width: 100%; border: none;"> <tr> <td style="padding: 0 10px;">230V ±10% 3ph 60Hz</td> <td style="padding: 0 10px;">5hp-40hp</td> <td style="padding: 0 10px;">(4kW-30kW)</td> </tr> <tr> <td style="padding: 0 10px;">460V ±10% 3ph 60Hz</td> <td style="padding: 0 10px;">5hp-175hp</td> <td style="padding: 0 10px;">(4kW-132kW)</td> </tr> <tr> <td style="padding: 0 10px;">575V ±10% 3ph 60Hz</td> <td style="padding: 0 10px;">5hp-175hp</td> <td style="padding: 0 10px;">(4kW-132kW)</td> </tr> </table> <p style="margin: 10px 0 0 0;">Power supply: WYE system with center point solidly grounded</p> </div>								230V ±10% 3ph 60Hz	5hp-40hp	(4kW-30kW)	460V ±10% 3ph 60Hz	5hp-175hp	(4kW-132kW)	575V ±10% 3ph 60Hz	5hp-175hp	(4kW-132kW)																							
230V ±10% 3ph 60Hz	5hp-40hp	(4kW-30kW)																																					
460V ±10% 3ph 60Hz	5hp-175hp	(4kW-132kW)																																					
575V ±10% 3ph 60Hz	5hp-175hp	(4kW-132kW)																																					
<p style="margin: 0;">KAESER KOMPRESSOREN SE</p> <p style="margin: 0;">Postfach 2143</p> <p style="margin: 0;">96410 Coburg</p>																																							
<p>ATTENTION !!!</p> <p>The document gives collective information on power supply voltages and frequencies for all machines. The voltage and frequency and local conditions under which any particular machine may be used are given on the nameplate of the machine and in the accompanying service manual.</p> <p>The drawings remain our exclusive property. They are entrusted only for the agreed purpose. Copies or any other reproductions, including storage, treatment and dissemination by use of electronic systems must not be made for any other than the agreed purpose. Neither originals nor reproductions must be forwarded or otherwise made accessible to third parties.</p>																																							
<table border="1" style="width: 100%; border-collapse: collapse;"> <tr> <td style="width: 10%; font-size: 0.8em;">c</td> <td style="width: 10%; font-size: 0.8em;">Date</td> <td style="width: 10%;">14.12.2020</td> <td style="width: 10%; font-size: 0.8em;">USE</td> <td style="width: 10%;"></td> <td style="width: 10%;"></td> <td style="width: 10%;"></td> <td style="width: 10%;"></td> </tr> <tr> <td style="font-size: 0.8em;">b</td> <td style="font-size: 0.8em;">Drawn</td> <td style="font-size: 0.8em;">M.Zeesh</td> <td></td> <td></td> <td></td> <td></td> <td></td> </tr> <tr> <td style="font-size: 0.8em;">a</td> <td style="font-size: 0.8em;">Released</td> <td style="font-size: 0.8em;">M.Zeesh</td> <td></td> <td></td> <td></td> <td></td> <td></td> </tr> <tr> <td style="font-size: 0.8em;">A</td> <td style="font-size: 0.8em;">Change</td> <td style="font-size: 0.8em;">Date</td> <td style="font-size: 0.8em;">Name</td> <td></td> <td></td> <td></td> <td></td> </tr> </table>								c	Date	14.12.2020	USE					b	Drawn	M.Zeesh						a	Released	M.Zeesh						A	Change	Date	Name				
c	Date	14.12.2020	USE																																				
b	Drawn	M.Zeesh																																					
a	Released	M.Zeesh																																					
A	Change	Date	Name																																				
<p style="font-size: 0.8em; margin: 0;">KAESER KOMPRESSOREN SX6.STC-U3010.02</p>				<p style="font-size: 0.8em; margin: 0;">cover page Blower STC+SC2</p>																																			
						<p style="font-size: 0.8em; margin: 0;">DXB.STC-U3020.06</p>	<p style="font-size: 0.8em; margin: 0;">page 1 1 Sht.</p>																																

Lfd. Nr. No.	Benennung Name	Zeichnungsnummer (Kunde) Drawing No. (customer)	Zeichnungsnummer (Hersteller) Drawing No. (manufacturer)	Blatt Page	Anlagenkennzeichen Unit designation
1	cover page		DXB.STC-U3020.06	1	
2	list of contents		ZXB.STC-U3020.06	1	
3	list of contents		ZXB.STC-U3020.06	2	
4	block diagram	instructions + option component legend	UXB.STC-U3020.06	1	
5	block diagram		UXB.STC-U3020.06	2	
6	electrical component parts list	Common parts	UXB.STC-U3020.06	3	
7	electrical component parts list	Common parts	UXB.STC-U3020.06	4	
8	electrical component parts list	option	UXB.STC-U3020.06	5	
9	electrical component parts list	option	UXB.STC-U3020.06	6	
10	electrical component parts list	performance-related components	UXB.STC-U3020.06	7	
11	electrical component parts list	performance-related components	UXB.STC-U3020.06	8	
12	electrical component parts list	performance-related components	UXB.STC-U3020.06	9	
13	electrical component parts list	performance-related components	UXB.STC-U3020.06	10	
14	electrical component parts list	performance-related components	UXB.STC-U3020.06	11	
15	electrical component parts list	performance-related components	UXB.STC-U3020.06	12	
16	electrical component parts list	performance-related components	UXB.STC-U3020.06	13	
17	electrical component parts list	performance-related components	UXB.STC-U3020.06	14	
18	electrical component parts list	performance-related components	UXB.STC-U3020.06	15	
19	electrical component parts list	performance-related components	UXB.STC-U3020.06	16	
20	electrical component parts list	performance-related components	UXB.STC-U3020.06	17	
21	electrical component parts list	performance-related components	UXB.STC-U3020.06	18	
22	electrical component parts list	performance-related components	UXB.STC-U3020.06	19	
23	electrical component parts list	performance-related components	UXB.STC-U3020.06	20	
24	electrical component parts list	performance-related components	UXB.STC-U3020.06	21	
25	electrical component parts list	performance-related components	UXB.STC-U3020.06	22	
26	electrical component parts list	performance-related components	UXB.STC-U3020.06	23	
27	electrical component parts list	performance-related components	UXB.STC-U3020.06	24	
28	electrical component parts list	performance-related components	UXB.STC-U3020.06	25	
29	electrical component parts list	performance-related components	UXB.STC-U3020.06	26	
30	electrical component parts list	performance-related components	UXB.STC-U3020.06	27	
31	electrical component parts list	performance-related components	UXB.STC-U3020.06	28	
32	wiring diagram	power unit	SXB.STC-U3020.06	1	
33	wiring diagram	power unit vent	SXB.STC-U3020.06	2	
34	wiring diagram	control voltage	SXB.STC-U3020.06	3	
35	wiring diagram	Gear housing ventilation + venting valve	SXB.STC-U3020.06	4	
36	wiring diagram	type speed supervisory module	SXB.STC-U3020.06	5	
37	wiring diagram	Oil return + SCZ + IOM	SXB.STC-U3020.06	6	
38	wiring diagram	IOM-configuration	SXB.STC-U3020.06	7	
39	wiring diagram	digital inputs IOM	SXB.STC-U3020.06	8	
40	wiring diagram	analog inputs IOM	SXB.STC-U3020.06	9	
41	wiring diagram	Relay-outputs	SXB.STC-U3020.06	10	
42	wiring diagram	Handling terminals	SXB.STC-U3020.06	11	
43	wiring diagram	Feed line connection	SXB.STC-U3020.06	12	
44	wiring diagram	Feed line connection	SXB.STC-U3020.06	13	
45	terminal connection	-X0,-X11,-X12,-X13	KXB.STC-U3020.06	1	

list of contents



Date 14.12.2020
Drawn M.Zeeh
Released M.Zeeh

Date Name

page 1
2 Sht.

ZXB.STC-U3020.06

Lfd. Nr. No.	Benennung Name	Zeichnungsnummer (Kunde) Drawing No. (customer)	Zeichnungsnummer (Hersteller) Drawing No. (manufacturer)	Blatt Page	Anlagenkennzeichen Unit designation
46	terminal connection	-X15,-X16,-X21,-X22,-X100	KXB.STC-U3020.06	2	
47	lay-out	control panel BBxxx	AXB.STC-U3020.06	1	
48	lay-out	control panel CB/DB xxx	AXB.STC-U3020.06	2	
49	lay-out	control panel EBxxx	AXB.STC-U3020.06	3	
50	lay-out	control panel FBxxx	AXB.STC-U3020.06	4	

c	Date	14.12.2020	list of contents	=	+	ZXB.STC-U3020.06	page	2
b	Drawn	M.Zeesh						
a	Released	M.Zeesh						
B	Change	Date	Name					

1	2	3	4	5	6	7	8
-B1/-B4 -B5 -B21 -B24 -B40/-B43 -B55 -B59 -B60 -B70 -B80/-B81 -B90	pressure transducer (4...20mA) differential pressure switch filter clogging overload relay motor Blower overload relay vent motor soundproofing casing temperature probe Blower (PT100) temperature probe PT100 (option) thermal overload releasing relay thermistors, compressor motor temperature probe soundproofing casing oil level switch speed sensors						
-1FU -2FU -3FU -9FU -10FU -12FU -29FU	fuse control voltage tapping primary control fuse control transformer secondary control fuse control transformer fuse start unloading ball valve (-M23/-M24) fuse 24V-AC fuse auto-transformer 575V/460V fuse phase sequence relay						
-K1 -K10 -K20 -K21 -K26 -K29 -K52 -K53 -K55 -K60	solenoid valve solenoid valve Oil return SIGMA CONTROL 2 (SC2) (MCS) SIGMA CONTROL 2 (SC2) (IOM-Modul) speed supervisory module phase sequence relay coupling relay solenoid valve coupling relay start unloading ball valve (-M23/-M24) coupling relay Oil return contactor EMERGENCY STOP (external/customer)						
-M1 -M4 -M10 -M23 -M24	motor Blower ventilator soundproofing casing vacuum pump Gear housing ventilation motor start unloading ball valve motor start unloading ball valve						
-Q1 -Q2 -Q3 -Q4	main contactor delta contactor wye contactor contactor ventilator soundproofing casing						
-S1 -S9	EMERGENCY STOP pushbutton REMOTE reset fault message						
-T11 -T12 -T21 -T45	control transformer 230V-AC auto-transformer 575V/460V control voltage supply 24V-DC isolating amplifier						
-X0 -X11 -X12 -X15 -X16 -X21 -X22 -X100	terminal strip, power supply terminal strip, control SC2-IOM digital outputs SC2-IOM digital inputs analog signals (external) control voltage 24V-DC not used EMERGENCY STOP (external/customer)						
-K20	Main Control System SC2 MCS						
-X1 -X2 -X3 -X4 -X5 -X6	Ethernet IO-BUS RS485-FC (USS-Bus) communication module SD card slot ground connection						
-K21	IO-Modul SC2 IOM-1 inside						
-X1 -X2 -X3 -X4 -X5,-X9 -X6 -X7 -X8	IO-Bus input IO-Bus output digital inputs power supply unit and Transistor outputs Relay outputs analog input 0-20mA analog input PT100 digital inputs						
-X11...-X13 -X14...-X17 -X18...-X29 -X30...-X32	external analog inputs 0-20mA analog inputs PT100 digital inputs digital outputs						



block diagram
Blower STC+SC2
component legend

c	Date	14.12.2020
b	Drawn	M.Zeesh
a	Released	M.Zeesh
C: Change	Date	Name

=		+
UXB-STC-U3020.06		page 2
		28 Sht

model	Common parts				page 4 28 Sht
	5 - 20 hp	5 - 20 hp	5 - 175 hp	5 - 175 hp	
machine power supply	208 V ±10 %, 60 Hz (4-15 kW)	230 V ±10 %, 60 Hz (4-15 kW)	460 V ±10 %, 60 Hz (4-132 kW)	575 V ±10 %, 60 Hz (4-132 kW)	= + UXB-STC-U3020.06
interference suppressor Siemens	7.8740.05130 3RT2916-1CC00	7.8740.05130 3RT2916-1CC00	7.8740.05130 3RT2916-1CC00	7.8740.05130 3RT2916-1CC00	
Not-Halt -S1	834424.0 subassembly complete	834424.0 subassembly complete	834424.0 subassembly complete	834424.0 subassembly complete	
control transformer -T11 Block	7.2238.10090 USTE630 - 630 VA 208-600 V/2x 115 V+ 24 V	7.2238.10090 USTE630 - 630 VA 208-600 V/2x 115 V+ 24 V	7.2238.10090 USTE630 - 630 VA 208-600 V/2x 115 V+ 24 V	7.2238.10090 USTE630 - 630 VA 208-600 V/2x 115 V+ 24 V	
power supply -T21 Prodrive	7.7605P0 PSDC24/2.5 100-240 V-AC/24 V-DC 2,5 A	7.7605P0 PSDC24/2.5 100-240 V-AC/24 V-DC 2,5 A	7.7605P0 PSDC24/2.5 100-240 V-AC/24 V-DC 2,5 A	7.7605P0 PSDC24/2.5 100-240 V-AC/24 V-DC 2,5 A	
isolating amplifier -T45 Phoenix	7.2892.00040 MCR-C-1/1-00-DC	7.2892.00040 MCR-C-1/1-00-DC	7.2892.00040 MCR-C-1/1-00-DC	7.2892.00040 MCR-C-1/1-00-DC	
control line terminal -X. 11/12/15/16/21/22/100 Handling	895635.0 Wieland WTP fig. 1, Sht. 11	895635.0 Wieland WTP fig. 1, Sht. 11	895635.0 Wieland WTP fig. 1, Sht. 11	895635.0 Wieland WTP fig. 1, Sht. 11	

model	option			
	BB	BB	BB	BB
machine power supply	208 V / 60 Hz	230 V / 60 Hz	460 V / 60 Hz	575 V / 60 Hz
option C5/C39: oil function monitors				
oil level switch (option C5)	-B80/-B81 Elobau	---	---	---
oil temperature (option C39)	-B55 Wika	---	---	---
option C10: Speed monitoring				
supervisory module	-K26 ifm	895323.0 FR1 - DD2503	895323.0 FR1 - DD2503	895323.0 FR1 - DD2503
speed sensor	-B90 ifm	895039.0 IFC201	895039.0 IFC201	895039.0 IFC201
option C11: Unloaded start valve 24 V-DC (electromagnetic)				
solenoid valve	-K1 Riegler	---	---	---
option C11: Unloaded start valve 115 V-AC (electromagnetic)				
solenoid valve	-K1 bürkert	893584.00010 115V/60 Hz (1PH/N/GRD)	893584.00010 115V/60 Hz (1PH/N/GRD)	893584.00010 115V/60 Hz (1PH/N/GRD)
coupling relay	-K52 Wieland	7.3149.00660 FLARE 24 V-DC 1W-250 V/6 A	7.3149.00660 FLARE 24 V-DC 1W-250 V/6 A	7.3149.00660 FLARE 24 V-DC 1W-250 V/6 A
option C11: Unloaded start valve 115 V-AC (ball valve)				
coupling relay	-K53 Siemens	---	---	---
actuator drive	-M23 / (-M24) Sun Yeh	---	---	---
fuse	-9FU Gould	---	---	---

page	5
28 Sht	
UXB-STC-U3020.06	
electrical component parts list	
Blower STC+SC2	
option	

Date	14.12.2020
Drawn	M.Zeeh
Released	M.Zeeh
Name	
Date	
C Change	

model	option CB-DB-EB CB-DB-EB CB-DB-EB CB-DB-EB FB					page 28 Sht
machine power supply	208 V / 60 Hz	230 V / 60 Hz	460 V / 60 Hz	575 V / 60 Hz	460 V+ 575 V / 60 Hz	= + UXB-STC-U3020.06
option C5/C39: oil function monitors						
oil level switch (option C5)	-B80/-B81 Elobau	894631.00010	894631.00010	894631.00010	894631.00010	electrical component parts list Blower STC+SC2 option
oil temperature (option C39)	-B55 Wika	895251.10100 (xB-C) 895603.00100 (EB-S) Pt100	895251.10100 (xB-C) 895603.00100 (EB-S) Pt100	895251.10100 (xB-C) 895603.00100 (EB-S) Pt100	895251.10100 (xB-C) 895603.00100 (EB-S) Pt100	
option C10: Speed monitoring						
supervisory module	-K26 ifm	895323.0 FR1 - DD2503	895323.0 FR1 - DD2503	895323.0 FR1 - DD2503	895323.0 FR1 - DD2503	KAESER KOMPRESSOREN
speed sensor	-B90 ifm	895039.0 IFC201	895039.0 IFC201	895039.0 IFC201	895039.0 IFC201	
option C11: Unloaded start valve 24 V-DC (electromagnetic) (only EBS+ FBS)						
solenoid valve	-K1 Riegler	894204.00020 24V - DC	894204.00020 24V - DC	894204.00020 24V - DC	894204.00020 24V - DC	
option C11: Unloaded start valve 115 V-AC (ball valve) (only EBS)						
coupling relay	-K53 Siemens	7.8237.00340 3RH2122-2JB40 DC 17-30 V AC-15: 240 V/10 A	7.8237.00340 3RH2122-2JB40 DC 17-30 V AC-15: 240 V/10 A	7.8237.00340 3RH2122-2JB40 DC 17-30 V AC-15: 240 V/10 A	7.8237.00340 3RH2122-2JB40 DC 17-30 V AC-15: 240 V/10 A	Date 14.12.2020 Drawn M.Zeeh Released M.Zeeh
actuator drive	-M23 / (-M24) Sun Yeh	895449.00010 OM-1 110 V	895449.00010 OM-1 110 V	895449.00010 OM-1 110 V	895449.00010 OM-1 110 V	
fuse	-9FU Gould	7.3304.00010 ATDR 2 A - 600 V class CC	7.3304.00010 ATDR 2 A - 600 V class CC	7.3304.00010 ATDR 2 A - 600 V class CC	7.3304.00010 ATDR 2 A - 600 V class CC	
fuse socket	-9FU Wöhner	1-pole - 7.3320.00050 cl. CC Ambus Easy Switch	1-pole - 7.3320.00050 cl. CC Ambus Easy Switch	1-pole - 7.3320.00050 cl. CC Ambus Easy Switch	1-pole - 7.3320.00050 cl. CC Ambus Easy Switch	
						Date
						Name
						Date
						C Change

model	performance-related components				page 7 28 Sht
	5 hp BB (4 kW)	7,5 hp BB+ CB+DB (5,5 kW)	10 hp BB+ CB+DB (7,5 kW)	15 hp BB+ CB+DB (11 kW)	
machine power supply	208 V ±10 %, 60 Hz	208 V ±10 %, 60 Hz	208 V ±10 %, 60 Hz	208 V ±10 %, 60 Hz	= + UXB-STC-U3020.06
overload relay -B21 Siemens	7.8741.00070 3RB3026-1QB0 6-25 A / S0 setting: 7,2 A NEC 430.32(C) incremental setting: 8,1 A	7.8741.00070 3RB3026-1QB0 6-25 A / S0 setting: 9,8 A NEC 430.32(C) incremental setting: 11,0 A	7.8741.00070 3RB3026-1QB0 6-25 A / S0 setting: 13,3 A NEC 430.32(C) incremental setting: 15,0 A	7.8741.00080 3RB3026-1VB0 10-40 A / S0 setting: 19,7 A NEC 430.32(C) incremental setting: 22,2 A	
overload relay soundproofing casing -B24 Siemens	7.8741.00030 3RB3016-1PB0 1,00-4,00 A / S00 setting: 1,43 A NEC 430.32(C) incremental setting: 1,61 A	7.8741.00030 3RB3016-1PB0 1,00-4,00 A / S00 setting: 1,43 A NEC 430.32(C) incremental setting: 1,61 A	7.8741.00030 3RB3016-1PB0 1,00-4,00 A / S00 setting: 1,43 A NEC 430.32(C) incremental setting: 1,61 A	7.8741.00030 3RB3016-1PB0 1,00-4,00 A / S00 setting: 1,43 A NEC 430.32(C) incremental setting: 1,61 A	
Blower motor -M1 Siemens	894989.0 208V-DD/60 Hz	894990.0 208V-DD/60 Hz	894991.0 208V-DD/60 Hz	894992.0 208V-DD/60 Hz	
vent motor soundproofing casing -M4 ebm	895260.00010 W2D250 115 V/60 Hz (1PH/N/GRD) 175W 1,55 A	895260.00010 W2D250 115 V/60 Hz (1PH/N/GRD) 175W 1,55 A	895260.00010 W2D250 115 V/60 Hz (1PH/N/GRD) 175W 1,55 A	895260.00010 W2D250 115 V/60 Hz (1PH/N/GRD) 175W 1,55 A	
contactor -Q1 / -Q2	7.8740.00350 3RT2024-1AK60	7.8740.00360 3RT2025-1AK60	7.8740.00370 3RT2026-1AK60	7.8740.00390 3RT2028-1AK60	electrical component parts list 208V BB+CB+DB performance-related components
auxiliary switch auxiliary switch interference suppressor terminal Phase rail Siemens	7.8740.05140 3RT2926-1CC00 7.3140.05080 3RV2925-5EB 7.6861.0 3RV1915-1AB	7.8740.05140 3RT2926-1CC00 7.3140.05080 3RV2925-5EB 7.6861.0 3RV1915-1AB	7.8740.05140 3RT2926-1CC00 7.3140.05080 3RV2925-5EB 7.6861.0 3RV1915-1AB	7.8740.05140 3RT2926-1CC00 7.3140.05080 3RV2925-5EB 7.6861.0 3RV1915-1AB	
contactor -Q3	7.8740.00310 3RT2016-1AK61	7.8740.00310 3RT2016-1AK61	7.8740.00330 3RT2018-1AK61	7.8740.00380 3RT2027-1AK60	
auxiliary switch auxiliary switch interference suppressor wye bridge Siemens	7.8740.05010 3RH2911-1HA11 7.8740.05130 3RT2916-1CC00 7.3140.05030 3RT1916-4BA31	7.8740.05010 3RH2911-1HA11 7.8740.05130 3RT2916-1CC00 7.3140.05030 3RT1916-4BA31	7.8740.05010 3RH2911-1HA11 7.8740.05130 3RT2916-1CC00 7.3140.05030 3RT1916-4BA31	7.8740.05140 3RT2926-1CC00 7.3140.02070 3RT1926-4BA31	
motor cable -W19.1/19.2	4x14 AWG / 4G2,5 mm ² 600 V - 90°C	4x14 AWG / 4G2,5 mm ² 600 V - 90°C	4x12 AWG / 4G4 mm ² 600 V - 90°C	4x10 AWG / 4G6 mm ² 600 V - 90°C	
connection -W11 -W13 -W14	10 AWG / 6 mm ² Phase rail 14 AWG / 2,5 mm ² 600 V - 90°C	10 AWG / 6 mm ² Phase rail 14 AWG / 2,5 mm ² 600 V - 90°C	8 AWG / 10 mm ² Phase rail 14 AWG / 2,5 mm ² 600 V - 90°C	8 AWG / 10 mm ² Phase rail Phase rail 14 AWG / 2,5 mm ² 600 V - 90°C	
supply terminals -X0: U1/V1/W1/GRD	894864.00010 14-4 AWG / 2,5-16 mm ² Wieland fig. 2, Sht. 11 16 mm fig. 1, Sht. 12	894864.00010 14-4 AWG / 2,5-16 mm ² Wieland fig. 2, Sht. 11 16 mm fig. 1, Sht. 12	894864.00010 14-4 AWG / 2,5-16 mm ² Wieland fig. 2, Sht. 11 16 mm fig. 1, Sht. 12	894864.00010 14-4 AWG / 2,5-16 mm ² Wieland fig. 2, Sht. 11 16 mm fig. 1, Sht. 12	
supply Handling Stripped length X connection					
					Date 14.12.2020
					Drawn M.Zeesh
					Released M.Zeesh
					Name
					Date
					C Change

model	performance-related components					page 28 Sht
	20 hp BB+ CB+DB (15 kW)	25 hp CB+ DB (18,5 kW)	30 hp CB+ DB (22 kW)	40 hp CB (30 kW)	40 hp DB (30 kW)	
machine power supply	208 V ±10 %, 60 Hz	208 V ±10 %, 60 Hz	208 V ±10 %, 60 Hz	208 V ±10 %, 60 Hz	208 V ±10 %, 60 Hz	= + UXB-STC-U3020.06
overload relay -B21 Siemens	7.8741.00090 3RB3036-1UB0 12,5-50 A / S2 setting: 26,6 A NEC 430.32(C) incremental setting: 30,0 A	7.8741.00090 3RB3036-1UB0 12,5-50 A / S2 setting: 31,9 A NEC 430.32(C) incremental setting: 36,0 A	7.8741.00100 3RB3036-1WB0 20-80 A / S2 setting: 38,2 A NEC 430.32(C) incremental setting: 43,2 A	7.8741.00100 3RB3036-1WB0 20-80 A / S2 setting: 52,1 A NEC 430.32(C) incremental setting: 58,8 A	7.8741.00100 3RB3036-1WB0 20-80 A / S2 setting: 54,2 A NEC 430.32(C) incremental setting: 61,2 A	
overload relay soundproofing casing -B24 Siemens	7.8741.00030 3RB3016-1PB0 1,00-4,00 A / S00 setting: 1,43 A NEC 430.32(C) incremental setting: 1,61 A	7.8741.00030 3RB3016-1PB0 1,00-4,00 A / S00 setting: 1,43 A NEC 430.32(C) incremental setting: 1,61 A	7.8741.00030 3RB3016-1PB0 1,00-4,00 A / S00 setting: 1,43 A NEC 430.32(C) incremental setting: 1,61 A	7.8741.00030 3RB3016-1PB0 1,00-4,00 A / S00 setting: 1,43 A NEC 430.32(C) incremental setting: 1,61 A	7.8741.00030 3RB3016-1PB0 1,00-4,00 A / S00 setting: 1,43 A NEC 430.32(C) incremental setting: 1,61 A	
Blower motor -M1 Siemens	895049.0 208V-DD/60 Hz	894994.0 208V-DD/60 Hz	894995.0 208V-DD/60 Hz	894996.1 (CB) 208V-DD/60 Hz	894997.1 (DB) 208V-DD/60 Hz	electrical component parts list 208V BB+CB+DB performance-related components
vent motor soundproofing casing -M4 ebm	895260.00010 W2D250 115 V/60 Hz (1PH/N/GRD) 175W 1,55 A	895260.00010 W2D250 115 V/60 Hz (1PH/N/GRD) 175W 1,55 A	895260.00010 W2D250 115 V/60 Hz (1PH/N/GRD) 175W 1,55 A	895260.00010 W2D250 115 V/60 Hz (1PH/N/GRD) 175W 1,55 A	895260.00010 W2D250 115 V/60 Hz (1PH/N/GRD) 175W 1,55 A	
contactor -Q1 / -Q2	7.8740.00400 3RT2035-1AK60	7.8740.00400 3RT2035-1AK60	7.8740.00420 3RT2037-1AK60	7.8740.00430 3RT2038-1AK60	7.8740.00430 3RT2038-1AK60	KAESER KOMPRESSOREN
auxiliary switch	
auxiliary switch	
interference suppressor	7.8740.05150 3RT2936-1CC00	7.8740.05150 3RT2936-1CC00	7.8740.05150 3RT2936-1CC00	7.8740.05150 3RT2936-1CC00	7.8740.05150 3RT2936-1CC00	
terminal	7.3140.05070 3RV2935-5E	7.3140.05070 3RV2935-5E	7.3140.05070 3RV2935-5E	7.3140.05070 3RV2935-5E	7.3140.05070 3RV2935-5E	
Phase rail	7.3140.05270 3RA2933-3FA00	7.3140.05270 3RA2933-3FA00	7.3140.05270 3RA2933-3FA00	7.3140.05270 3RA2933-3FA00	7.3140.05270 3RA2933-3FA00	
contactor -Q3	7.8740.00400 3RT2035-1AK60	7.8740.00400 3RT2035-1AK60	7.8740.00400 3RT2035-1AK60	7.8740.00400 3RT2035-1AK60	7.8740.00400 3RT2035-1AK60	Date 14.12.2020 Drawn M.Zeesh Released M.Zeesh Name Date C Change
auxiliary switch	
auxiliary switch	
interference suppressor	7.8740.05150 3RT2936-1CC00	7.8740.05140 3RT2926-1CC00	7.8740.05150 3RT2936-1CC00	7.8740.05150 3RT2936-1CC00	7.8740.05150 3RT2936-1CC00	
wye bridge	7.3140.01170 3RT1936-4BA31	7.3140.02070 3RT1926-4BA31	7.3140.01170 3RT1936-4BA31	7.3140.01170 3RT1936-4BA31	7.3140.01170 3RT1936-4BA31	
motor cable -W19.1/19.2	4x8 AWG / 4G10 mm ² 600 V - 90°C	4x6 AWG / 4G16 mm ² 600 V - 90°C	4x6 AWG / 4G16 mm ² 600 V - 90°C	4x4 AWG / 4G25 mm ² 600 V - 90°C	4x4 AWG / 4G25 mm ² 600 V - 90°C	
connection -W11 Phase rail -W13 Phase rail -W14 Phase rail	4 AWG / 25 mm2 600 V - 90°C	4 AWG / 25 mm2 600 V - 90°C	2 AWG / 35 mm2 600 V - 90°C	1 AWG / 50 mm2 600 V - 90°C	1 AWG / 50 mm2 600 V - 90°C	
supply terminals -X0: U1/V1/W1/GRD	3x 895314.0 3x 895314.00010 4x 895314.00040 8-1 AWG / 10-50 mm ² Wago fig. 3, Sht. 11 30 mm	3x 895314.0 3x 895314.00010 4x 895314.00040 8-1 AWG / 10-50 mm ² Wago fig. 3, Sht. 11 30 mm	3x 895314.0 3x 895314.00010 4x 895314.00040 8-1 AWG / 10-50 mm ² Wago fig. 3, Sht. 11 30 mm	3x 894385.0 3x 894385.00010 4x 894385.00040 4-4/0 AWG / 25-95 mm ² Wago fig. 3, Sht. 11 36 mm	3x 894385.0 3x 894385.00010 4x 894385.00040 4-4/0 AWG / 25-95 mm ² Wago fig. 3, Sht. 11 36 mm	
supply Handling Stripped length X connection	fig. 2, Sht. 12	fig. 2, Sht. 12	fig. 2, Sht. 12	fig. 2, Sht. 12	fig. 2, Sht. 12	

model	performance-related components			page 9 28 Sht														
	25 hp EB (18,5 kW)	30 hp EB (22 kW)	40 hp EB (30 kW)															
machine power supply	208 V ±10 %, 60 Hz	208 V ±10 %, 60 Hz	208 V ±10 %, 60 Hz	= + UXB-STC-U3020.06														
overload relay -B21 Siemens	7.8741.00090 3RB3036-1UB0 12.5-50 A / S2 setting: 31,9 A NEC 430.32(C) incremental setting: 36,0 A	7.8741.00100 3RB3036-1WB0 20-80 A / S2 setting: 38,2 A NEC 430.32(C) incremental setting: 43,2 A	7.8741.00100 3RB3036-1WB0 20-80 A / S2 setting: 54,2 A NEC 430.32(C) incremental setting: 61,2 A															
overload relay soundproofing casing -B24 Siemens	7.8741.00020 3RB3016-1NB0 0,32-1,25 A / S00 setting: 0,98 A NEC 430.32(C) incremental setting: 1,10 A	7.8741.00020 3RB3016-1NB0 0,32-1,25 A / S00 setting: 0,98 A NEC 430.32(C) incremental setting: 1,10 A	7.8741.00020 3RB3016-1NB0 0,32-1,25 A / S00 setting: 0,98 A NEC 430.32(C) incremental setting: 1,10 A	electrical component parts list 208V EB performance-related components														
Blower motor -M1 Siemens	894994.0 208V-DD/60 Hz	894995.0 208V-DD/60 Hz	894997.1 208V-DD/60 Hz															
vent motor soundproofing casing -M4 Sodeca	895040.00020 HC-31-2T / H-I-E 208 V-D/60 Hz (3PH/GRD) 180W 1,06 A	895040.00020 HC-31-2T / H-I-E 208 V-D/60 Hz (3PH/GRD) 180W 1,06 A	895040.00020 HC-31-2T / H-I-E 208 V-D/60 Hz (3PH/GRD) 180W 1,06 A															
contactor -Q1 / -Q2	7.8740.00400 3RT2035-1AK60	7.8740.00420 3RT2037-1AK60	7.8740.00430 3RT2038-1AK60															
auxiliary switch -	7.8740.05030 3RH2911-1HA20	7.8740.05030 3RH2911-1HA20	7.8740.05030 3RH2911-1HA20															
auxiliary switch -																		
interference suppressor -	7.8740.05150 3RT2936-1CC00	7.8740.05150 3RT2936-1CC00	7.8740.05150 3RT2936-1CC00															
terminal -	7.3140.05070 3RV2935-5E	7.3140.05070 3RV2935-5E	7.3140.05070 3RV2935-5E															
Phase rail -	7.3140.05270 3RA2933-3FA00	7.3140.05270 3RA2933-3FA00	7.3140.05270 3RA2933-3FA00															
contactor -Q3	7.8740.00400 3RT2035-1AK60	7.8740.00400 3RT2035-1AK60	7.8740.00400 3RT2035-1AK60															
auxiliary switch -																		
auxiliary switch -																		
interference suppressor -	7.8740.05150 3RT2936-1CC00	7.8740.05150 3RT2936-1CC00	7.8740.05150 3RT2936-1CC00															
wye bridge -	7.3140.01170 3RT1936-4BA31	7.3140.01170 3RT1936-4BA31	7.3140.01170 3RT1936-4BA31															
motor cable -W19.1/19.2	4x6 AWG / 4G16 mm ² 600 V - 90°C	4x6 AWG / 4G16 mm ² 600 V - 90°C	4x4 AWG / 4G25 mm ² 600 V - 90°C															
connection -W11 -W13 -W14	4 AWG / 25 mm ² Phase rail Phase rail 600 V - 90°C	2 AWG / 35 mm ² Phase rail Phase rail 600 V - 90°C	1 AWG / 50 mm ² Phase rail Phase rail 600 V - 90°C															
supply terminals -X0: U1/V1/W1/GRD	3x 895314.0 3x 895314.00010 4x 895314.00040 8-1 AWG / 10-50 mm ² Wago fig. 3, Sht. 11 30 mm	3x 895314.0 3x 895314.00010 4x 895314.00040 8-1 AWG / 10-50 mm ² Wago fig. 3, Sht. 11 30 mm	3x 894385.0 3x 894385.00010 4x 894385.00040 4-4/0 AWG / 25-95 mm ² Wago fig. 3, Sht. 11 36 mm															
supply Stripped length X connection	fig. 2, Sht. 12	fig. 2, Sht. 12	fig. 2, Sht. 12															
<table border="1"> <tr> <td>c</td> <td>Date</td> <td>14.12.2020</td> </tr> <tr> <td>b</td> <td>Drawn</td> <td>M.Zeeh</td> </tr> <tr> <td>a</td> <td>Released</td> <td>M.Zeeh</td> </tr> <tr> <td>C Change</td> <td>Name</td> <td></td> </tr> <tr> <td></td> <td>Date</td> <td></td> </tr> </table>				c	Date	14.12.2020	b	Drawn	M.Zeeh	a	Released	M.Zeeh	C Change	Name			Date	
c	Date	14.12.2020																
b	Drawn	M.Zeeh																
a	Released	M.Zeeh																
C Change	Name																	
	Date																	

model	performance-related components				page 10 28 Sht
	5 hp BB (4 kW)	7,5 hp BB+ CB+DB (5,5 kW)	10 hp BB+ CB+DB (7,5 kW)	15 hp BB+ CB+DB (11 kW)	
machine power supply	230 V ±10 %, 60 Hz	230 V ±10 %, 60 Hz	230 V ±10 %, 60 Hz	230 V ±10 %, 60 Hz	UXB-STC-U3020.06
overload relay -B21 Siemens	7.8741.00070 3RB3026-1QB0 6-25 A / S0 setting: 6,9 A NEC 430.32(C) incremental setting: 7,7 A	7.8741.00070 3RB3026-1QB0 6-25 A / S0 setting: 9,9 A NEC 430.32(C) incremental setting: 11,1 A	7.8741.00070 3RB3026-1QB0 6-25 A / S0 setting: 13,2 A NEC 430.32(C) incremental setting: 14,8 A	7.8741.00080 3RB3026-1VB0 10-40 A / S0 setting: 20,3 A NEC 430.32(C) incremental setting: 22,8 A	
overload relay soundproofing casing -B24 Siemens	7.8741.00030 3RB3016-1PB0 1,00-4,00 A / S00 setting: 1,43 A NEC 430.32(C) incremental setting: 1,61 A	7.8741.00030 3RB3016-1PB0 1,00-4,00 A / S00 setting: 1,43 A NEC 430.32(C) incremental setting: 1,61 A	7.8741.00030 3RB3016-1PB0 1,00-4,00 A / S00 setting: 1,43 A NEC 430.32(C) incremental setting: 1,61 A	7.8741.00030 3RB3016-1PB0 1,00-4,00 A / S00 setting: 1,43 A NEC 430.32(C) incremental setting: 1,61 A	
Blower motor -M1 Siemens	894989.0 230V-DD/60 Hz	894990.0 230V-DD/60 Hz	894991.0 230V-DD/60 Hz	894992.0 230V-DD/60 Hz	
vent motor soundproofing casing -M4 ebm	895260.00010 W2D250 115 V/60 Hz (1PH/N/GRD) 175W 1,55 A	895260.00010 W2D250 115 V/60 Hz (1PH/N/GRD) 175W 1,55 A	895260.00010 W2D250 115 V/60 Hz (1PH/N/GRD) 175W 1,55 A	895260.00010 W2D250 115 V/60 Hz (1PH/N/GRD) 175W 1,55 A	
contactor -Q1 / -Q2	7.8740.00350 3RT2024-1AK60	7.8740.00370 3RT2026-1AK60	7.8740.00370 3RT2026-1AK60	7.8740.00390 3RT2028-1AK60	
auxiliary switch	
auxiliary switch	
interference suppressor	7.8740.05140 3RT2926-1CC00	7.8740.05140 3RT2926-1CC00	7.8740.05140 3RT2926-1CC00	7.8740.05140 3RT2926-1CC00	
terminal	7.3140.05080 3RV2925-5EB	7.3140.05080 3RV2925-5EB	7.3140.05080 3RV2925-5EB	7.3140.05080 3RV2925-5EB	
Phase rail	7.6861.0 3RV1915-1AB Siemens	7.6861.0 3RV1915-1AB	7.6861.0 3RV1915-1AB	7.6861.0 3RV1915-1AB	
contactor -Q3	7.8740.00310 3RT2016-1AK61	7.8740.00310 3RT2016-1AK61	7.8740.00330 3RT2018-1AK61	7.8740.00380 3RT2027-1AK60	
auxiliary switch	7.8740.05010 3RH2911-1HA11	7.8740.05010 3RH2911-1HA11	7.8740.05010 3RH2911-1HA11	7.8740.05010 3RH2911-1HA11	
auxiliary switch	
interference suppressor	7.8740.05130 3RT2916-1CC00	7.8740.05130 3RT2916-1CC00	7.8740.05130 3RT2916-1CC00	7.8740.05140 3RT2926-1CC00	
wye bridge	7.3140.05030 3RT1916-4BA31 Siemens	7.3140.05030 3RT1916-4BA31	7.3140.05030 3RT1916-4BA31	7.3140.02070 3RT1926-4BA31	
motor cable -W19.1/19.2	4x14 AWG / 4G2,5 mm ² 600 V - 90°C	4x14 AWG / 4G2,5 mm ² 600 V - 90°C	4x12 AWG / 4G4 mm ² 600 V - 90°C	4x10 AWG / 4G6 mm ² 600 V - 90°C	
connection -W11 -W13 -W14	10 AWG / 6 mm2 Phase rail 14 AWG / 2,5 mm2 600 V - 90°C	10 AWG / 6 mm2 Phase rail 14 AWG / 2,5 mm2 600 V - 90°C	8 AWG / 10 mm2 Phase rail 14 AWG / 2,5 mm2 600 V - 90°C	8 AWG / 10 mm2 Phase rail Phase rail 600 V - 90°C	
supply terminals -X0: U1/V1/W1/GRD	894864.00010 14-4 AWG / 2,5-16 mm ² Wieland fig. 2, Sht. 11 16 mm	894864.00010 14-4 AWG / 2,5-16 mm ² Wieland fig. 2, Sht. 11 16 mm	894864.00010 14-4 AWG / 2,5-16 mm ² Wieland fig. 2, Sht. 11 16 mm	894864.00010 14-4 AWG / 2,5-16 mm ² Wieland fig. 2, Sht. 11 16 mm	
supply Handling Stripped length X connection	fig. 1, Sht. 12	fig. 1, Sht. 12	fig. 1, Sht. 12	fig. 1, Sht. 12	

electrical component parts list
230V BB+CB+DB
performance-related components



c	Date	14.12.2020
b	Drawn	M.Zeesh
a	Released	M.Zeesh
C Change	Name	
	Date	

model	performance-related components				
	20 hp BB+ CB+DB (15 kW)	25 hp CB+ DB (18,5 kW)	30 hp CB+ DB (22 kW)	40 hp CB (30 kW)	40 hp DB (30 kW)
machine power supply	230 V ±10 %, 60 Hz	230 V ±10 %, 60 Hz	230 V ±10 %, 60 Hz	230 V ±10 %, 60 Hz	230 V ±10 %, 60 Hz
overload relay -B21 Siemens	7.8741.00090 3RB3036-1UB0 12,5-50 A / S2 setting: 27,7 A NEC 430.32(C) incremental setting: 31 A	7.8741.00090 3RB3036-1UB0 12,5-50 A / S2 setting: 32,4 A NEC 430.32(C) incremental setting: 36,3 A	7.8741.00100 3RB3036-1WB0 20-80 A / S2 setting: 38,1 A NEC 430.32(C) incremental setting: 42,7 A	7.8741.00140 3RB3046-1EB0 32-115 A / S3 setting: 54,3 A NEC 430.32(C) incremental setting: 60,8 A	7.8741.00140 3RB3046-1EB0 32-115 A / S3 setting: 54,3 A NEC 430.32(C) incremental setting: 60,8 A
overload relay soundproofing casing -B24 Siemens	7.8741.00030 3RB3016-1PB0 1,00-4,00 A / S00 setting: 1,43 A NEC 430.32(C) incremental setting: 1,61 A	7.8741.00030 3RB3016-1PB0 1,00-4,00 A / S00 setting: 1,43 A NEC 430.32(C) incremental setting: 1,61 A	7.8741.00030 3RB3016-1PB0 1,00-4,00 A / S00 setting: 1,43 A NEC 430.32(C) incremental setting: 1,61 A	7.8741.00030 3RB3016-1PB0 1,00-4,00 A / S00 setting: 1,43 A NEC 430.32(C) incremental setting: 1,61 A	7.8741.00030 3RB3016-1PB0 1,00-4,00 A / S00 setting: 1,43 A NEC 430.32(C) incremental setting: 1,61 A
Blower motor -M1 Siemens	895049.0 230V-DD/60 Hz	894994.0 230V-DD/60 Hz	894995.0 230V-DD/60 Hz	894996.1 (CB) 230V-DD/60 Hz	894997.1 (DB) 230V-DD/60 Hz
vent motor soundproofing casing -M4 ebm	895260.00010 W2D250 115 V/60 Hz (1PH/N/GRD) 175W 1,55 A	895260.00010 W2D250 115 V/60 Hz (1PH/N/GRD) 175W 1,55 A	895260.00010 W2D250 115 V/60 Hz (1PH/N/GRD) 175W 1,55 A	895260.00010 W2D250 115 V/60 Hz (1PH/N/GRD) 175W 1,55 A	895260.00010 W2D250 115 V/60 Hz (1PH/N/GRD) 175W 1,55 A
contactor -Q1 / -Q2	7.8740.00410 3RT2036-1AK60	7.8740.00400 3RT2035-1AK60	7.8740.00430 3RT2038-1AK60	7.8740.00440 3RT2045-1AK60	7.8740.00440 3RT2045-1AK60
auxiliary switch - auxiliary switch - interference suppressor - terminal - Phase rail - Siemens	7.8740.05150 3RT2936-1CC00 7.3140.05070 3RV2935-5E 7.3140.05270 3RA2933-3FA00	7.8740.05150 3RT2936-1CC00 7.3140.05070 3RV2935-5E 7.3140.05270 3RA2933-3FA00	7.8740.05150 3RT2936-1CC00 7.3140.05070 3RV2935-5E 7.3140.05270 3RA2933-3FA00	7.8740.05170 3RT2946-1CC00 3x 7.3140.02100 3x 3RA1943-3L 7.3140.05370 3RA2943-3FA00	7.8740.05170 3RT2946-1CC00 3x 7.3140.02100 3x 3RA1943-3L 7.3140.05370 3RA2943-3FA00
contactor -Q3	7.8740.00400 3RT2035-1AK60	7.8740.00400 3RT2035-1AK60	7.8740.00400 3RT2035-1AK60	7.8740.00400 3RT2035-1AK60	7.8740.00400 3RT2035-1AK60
auxiliary switch - auxiliary switch - interference suppressor - we bridge - Siemens	7.8740.05150 3RT2936-1CC00 7.3140.01170 3RT1936-4BA31	7.8740.05150 3RT2936-1CC00 7.3140.01170 3RT1936-4BA31	7.8740.05150 3RT2936-1CC00 7.3140.01170 3RT1936-4BA31	7.8740.05150 3RT2936-1CC00 7.3140.01170 3RT1936-4BA31	7.8740.05150 3RT2936-1CC00 7.3140.01170 3RT1936-4BA31
motor cable -W19.1/19.2	4x8 AWG / 4G10 mm ² 600 V - 90°C	4x6 AWG / 4G16 mm ² 600 V - 90°C	4x6 AWG / 4G16 mm ² 600 V - 90°C	4x4 AWG / 4G25 mm ² 600 V - 90°C	4x4 AWG / 4G25 mm ² 600 V - 90°C
connection -W11 Phase rail -W13 Phase rail -W14 Phase rail 600 V - 90°C	6 AWG / 16 mm ² Phase rail Phase rail 600 V - 90°C	4 AWG / 25 mm ² Phase rail Phase rail 600 V - 90°C	2 AWG / 35 mm ² Phase rail Phase rail 600 V - 90°C	1 AWG / 50 mm ² 4 AWG / 25 mm ² 8 AWG / 10 mm ² 600 V - 90°C	1 AWG / 50 mm ² 4 AWG / 25 mm ² 8 AWG / 10 mm ² 600 V - 90°C
supply terminals U1/V1/W1/GRD -X0: Handling Stripped length X connection	3x 895314.0 3x 895314.00010 4x 895314.00040 8-1 AWG / 10-50 mm ² Wago fig. 3, Sht. 11 30 mm fig. 2, Sht. 12	3x 895314.0 3x 895314.00010 4x 895314.00040 8-1 AWG / 10-50 mm ² Wago fig. 3, Sht. 11 30 mm fig. 2, Sht. 12	3x 895314.0 3x 895314.00010 4x 895314.00040 8-1 AWG / 10-50 mm ² Wago fig. 3, Sht. 11 30 mm fig. 2, Sht. 12	3x 894385.0 3x 894385.00010 4x 894385.00040 4-4/0 AWG / 25-95 mm ² Wago fig. 3, Sht. 11 36 mm fig. 2, Sht. 12	3x 894385.0 3x 894385.00010 4x 894385.00040 4-4/0 AWG / 25-95 mm ² Wago fig. 3, Sht. 11 36 mm fig. 2, Sht. 12
supply					

page 11
28 Sht

UXB-STC-U3020.06

electrical component parts list
230V BB+CB+DB
performance-related components

KAESER
KOMPRESSOREN

Date	14.12.2020	Date	
Drawn	M.Zeesh	Released	M.Zeesh
C Change		Name	
		Date	

model	performance-related components			=	+	page 12 28 Sht
	25 hp EB (18,5 kW)	30 hp EB (22 kW)	40 hp EB (30 kW)			
machine power supply	230 V ±10 %, 60 Hz	230 V ±10 %, 60 Hz	230 V ±10 %, 60 Hz			UXB-STC-U3020.06
overload relay -B21 Siemens	7.8741.00090 3RB3036-1UB0 12,5-50 A / S2 setting: 32,4 A NEC 430.32(C) incremental setting: 36,3 A	7.8741.00100 3RB3036-1WB0 20-80 A / S2 setting: 38,1 A NEC 430.32(C) incremental setting: 42,7 A	7.8741.00140 3RB3046-1EB0 32-115 A / S3 setting: 54,3 A NEC 430.32(C) incremental setting: 60,8 A			
overload relay soundproofing casing -B24 Siemens	7.8741.00030 3RB3016-1PB0 1,00-4,00 A / S00 setting: 1,01 A NEC 430.32(C) incremental setting: 1,14 A	7.8741.00030 3RB3016-1PB0 1,00-4,00 A / S00 setting: 1,01 A NEC 430.32(C) incremental setting: 1,14 A	7.8741.00030 3RB3016-1PB0 1,00-4,00 A / S00 setting: 1,01 A NEC 430.32(C) incremental setting: 1,14 A			
Blower motor -M1 Siemens	894994.0 230V-DD/60 Hz	894995.0 230V-DD/60 Hz	894997.1 230V-DD/60 Hz			
vent motor soundproofing casing -M4 Sodeca	895040.00040 HC-31-2T / H-I-E 230 V-D/60 Hz (3PH/GRD) 210W 1,10 A	895040.00040 HC-31-2T / H-I-E 230 V-D/60 Hz (3PH/GRD) 210W 1,10 A	895040.00040 HC-31-2T / H-I-E 230 V-D/60 Hz (3PH/GRD) 210W 1,10 A			
contactor -Q1 / -Q2	7.8740.00400 3RT2035-1AK60	7.8740.00430 3RT2038-1AK60	7.8740.00440 3RT2045-1AK60			
auxiliary switch .	7.8740.05030 3RH2911-1HA20	7.8740.05030 3RH2911-1HA20				
auxiliary switch .						
interference suppressor .	7.8740.05150 3RT2936-1CC00	7.8740.05150 3RT2936-1CC00	7.8740.05170 3RT2946-1CC00			
terminal .	7.3140.05070 3RV2935-5E	7.3140.05070 3RV2935-5E	3x 7.3140.02100 3x 3RA1943-3L			
Phase rail Siemens	7.3140.05270 3RA2933-3FA00	7.3140.05270 3RA2933-3FA00	7.3140.05370 3RA2943-3FA00			
contactor -Q3	7.8740.00400 3RT2035-1AK60	7.8740.00400 3RT2035-1AK60	7.8740.00410 3RT2036-1AK60			
auxiliary switch .						
auxiliary switch .						
interference suppressor .	7.8740.05150 3RT2936-1CC00	7.8740.05150 3RT2936-1CC00	7.8740.05150 3RT2936-1CC00			
wye bridge Siemens	7.3140.01170 3RT1936-4BA31	7.3140.01170 3RT1936-4BA31	7.3140.01170 3RT1936-4BA31			
motor cable -W19.1/19.2	4x6 AWG / 4G16 mm ² 600 V - 90°C	4x6 AWG / 4G16 mm ² 600 V - 90°C	4x4 AWG / 4G25 mm ² 600 V - 90°C			
connection -W11 Phase rail -W13 Phase rail -W14 Phase rail	4 AWG / 25 mm ² 600 V - 90°C	2 AWG / 35 mm ² 600 V - 90°C	1 AWG / 50 mm ² 4 AWG / 25 mm ² 8 AWG / 10 mm ² 600 V - 90°C			
supply terminals -X0: U1/V1/W1/GRD	3x 895314.0 3x 895314.00010 4x 895314.00040 8-1 AWG / 10-50 mm ² Wago fig. 3, Sht. 11 30 mm	3x 895314.0 3x 895314.00010 4x 895314.00040 8-1 AWG / 10-50 mm ² Wago fig. 3, Sht. 11 30 mm	3x 894385.0 3x 894385.00010 4x 894385.00040 4-4/0 AWG / 25-95 mm ² Wago fig. 3, Sht. 11 36 mm			
supply Stripped length X connection	fig. 2, Sht. 12	fig. 2, Sht. 12	fig. 2, Sht. 12			
<p>KAESER KOMPRESSOREN</p> <p>electrical component parts list 230V EB performance-related components</p>						
c	Date	14.12.2020				
b	Drawn	M.Zeeh				
a	Released	M.Zeeh				
C	Change					

model	performance-related components					page 13 28 Sht
	5 hp BB (4 kW)	7,5 hp BB+ CB+DB (5,5 kW)	10 hp BB+ CB+DB (7,5 kW)	15 hp BB+ CB+DB (11 kW)	20 hp BB+ CB+DB (15 kW)	
machine power supply	460 V ±10 %, 60 Hz	460 V ±10 %, 60 Hz	460 V ±10 %, 60 Hz	460 V ±10 %, 60 Hz	460 V ±10 %, 60 Hz	= + UXB-STC-U3020.06
overload relay -B21 Siemens	7.8741.00060 3RB3026-1SB0 3-12 A / S0 setting: 3,4 A NEC 430.32(C) incremental setting: 3,8 A	7.8741.00060 3RB3026-1SB0 3-12 A / S0 setting: 5 A NEC 430.32(C) incremental setting: 5,6 A	7.8741.00060 3RB3026-1SB0 3-12 A / S0 setting: 6,6 A NEC 430.32(C) incremental setting: 7,4 A	7.8741.00070 3RB3026-1QB0 6-25 A / S0 setting: 10,2 A NEC 430.32(C) incremental setting: 11,4 A	7.8741.00070 3RB3026-1QB0 6-25 A / S0 setting: 13,9 A NEC 430.32(C) incremental setting: 15,5 A	
overload relay soundproofing casing -B24 Siemens	7.8741.00030 3RB3016-1PB0 1,00-4,00 A / S00 setting: 1,43 A NEC 430.32(C) incremental setting: 1,61 A	7.8741.00030 3RB3016-1PB0 1,00-4,00 A / S00 setting: 1,43 A NEC 430.32(C) incremental setting: 1,61 A	7.8741.00030 3RB3016-1PB0 1,00-4,00 A / S00 setting: 1,43 A NEC 430.32(C) incremental setting: 1,61 A	7.8741.00030 3RB3016-1PB0 1,00-4,00 A / S00 setting: 1,43 A NEC 430.32(C) incremental setting: 1,61 A	7.8741.00030 3RB3016-1PB0 1,00-4,00 A / S00 setting: 1,43 A NEC 430.32(C) incremental setting: 1,61 A	
Blower motor -M1 Siemens	894989.0 460V-D/60 Hz	894990.0 460V-D/60 Hz	894991.0 460V-D/60 Hz	894992.0 460V-D/60 Hz	895049.0 460V-D/60 Hz	
vent motor soundproofing casing -M4 ebm	895260.00010 W2D250 (1PH/N/GRD) 115 V/60 Hz, 175W 1,55 A	895260.00010 W2D250 (1PH/N/GRD) 115 V/60 Hz, 175W 1,55 A	895260.00010 W2D250 (1PH/N/GRD) 115 V/60 Hz, 175W 1,55 A	895260.00010 W2D250 (1PH/N/GRD) 115 V/60 Hz, 175W 1,55 A	895260.00010 W2D250 (1PH/N/GRD) 115 V/60 Hz, 175W 1,55 A	
contactor auxiliary switch auxiliary switch interference suppressor terminal Phase rail -Q1 / -Q2 Siemens	7.8740.00340 3RT2023-1AK60 7.8740.05140 3RT2926-1CC00 7.3140.05080 3RV2925-5EB 7.6861.0 3RV1915-1AB	7.8740.00340 3RT2023-1AK60 7.8740.05140 3RT2926-1CC00 7.3140.05080 3RV2925-5EB 7.6861.0 3RV1915-1AB	7.8740.00350 3RT2024-1AK60 7.8740.05140 3RT2926-1CC00 7.3140.05080 3RV2925-5EB 7.6861.0 3RV1915-1AB	7.8740.00370 3RT2026-1AK60 7.8740.05140 3RT2926-1CC00 7.3140.05080 3RV2925-5EB 7.6861.0 3RV1915-1AB	7.8740.00390 3RT2028-1AK60 7.8740.05140 3RT2926-1CC00 7.3140.05080 3RV2925-5EB 7.6861.0 3RV1915-1AB	
contactor auxiliary switch auxiliary switch interference suppressor wye bridge -Q3 Siemens	7.8740.00310 3RT2016-1AK61 7.8740.05010 3RH2911-1HA11 7.8740.05130 3RT2916-1CC00 7.3140.05030 3RT1916-4BA31	7.8740.00310 3RT2016-1AK61 7.8740.05010 3RH2911-1HA11 7.8740.05130 3RT2916-1CC00 7.3140.05030 3RT1916-4BA31	7.8740.00310 3RT2016-1AK61 7.8740.05010 3RH2911-1HA11 7.8740.05130 3RT2916-1CC00 7.3140.05030 3RT1916-4BA31	7.8740.00330 3RT2018-1AK61 7.8740.05010 3RH2911-1HA11 7.8740.05130 3RT2916-1CC00 7.3140.05030 3RT1916-4BA31	7.8740.00370 3RT2026-1AK60 7.8740.05140 3RT2926-1CC00 7.3140.02070 3RT1926-4BA31	
motor cable -W19.1/19.2	4x14 AWG / 4G2,5 mm ² 600 V - 90°C	4x14 AWG / 4G2,5 mm ² 600 V - 90°C	4x14 AWG / 4G2,5 mm ² 600 V - 90°C	4x12 AWG / 4G4 mm ² 600 V - 90°C	4x10 AWG / 4G6 mm ² 600 V - 90°C	
connection -W11 -W13 -W14	14 AWG / 2,5 mm ² Phase rail 14 AWG / 2,5 mm ² 600 V - 90°C	14 AWG / 2,5 mm ² Phase rail 14 AWG / 2,5 mm ² 600 V - 90°C	14 AWG / 2,5 mm ² Phase rail 14 AWG / 2,5 mm ² 600 V - 90°C	10 AWG / 6 mm ² Phase rail 14 AWG / 2,5 mm ² 600 V - 90°C	8 AWG / 10 mm ² Phase rail Phase rail 600 V - 90°C	
supply terminals -X0: U1/V1/W1/GRD Handling Stripped length X connection	894864.00010 14-4 AWG / 2,5-16 mm ² Wieland fig. 2, Sht. 11 16 mm fig. 1, Sht. 12	894864.00010 14-4 AWG / 2,5-16 mm ² Wieland fig. 2, Sht. 11 16 mm fig. 1, Sht. 12	894864.00010 14-4 AWG / 2,5-16 mm ² Wieland fig. 2, Sht. 11 16 mm fig. 1, Sht. 12	894864.00010 14-4 AWG / 2,5-16 mm ² Wieland fig. 2, Sht. 11 16 mm fig. 1, Sht. 12	894864.00010 14-4 AWG / 2,5-16 mm ² Wieland fig. 2, Sht. 11 16 mm fig. 1, Sht. 12	
						KAESER KOMPRESSOREN electrical component parts list 460V BB+CB+DB performance-related components
						Date 14.12.2020 Drawn M.Zeesh Released M.Zeesh Name Date C Change

model	performance-related components					page 14 28 Sht
	25 hp CB+ DB (18,5 kW)	30 hp CB+ DB (22 kW)	40 hp CB+ DB (30 kW)	50 hp DB (37 kW)	60 hp DB (45 kW)	
machine power supply	460 V ±10 %, 60 Hz	460 V ±10 %, 60 Hz	460 V ±10 %, 60 Hz	460 V ±10 %, 60 Hz	460 V ±10 %, 60 Hz	UXB-STC-U3020.06
overload relay -B21 Siemens	7.8741.00080 3RB3026-1VB0 10-40 A / S0 setting: 16,2 A NEC 430.32(C) incremental setting: 18,2 A	7.8741.00090 3RB3036-1UB0 12,5-50 A / S2 setting: 19,1 A NEC 430.32(C) incremental setting: 21,3 A	7.8741.00090 3RB3036-1UB0 12,5-50 A / S2 setting: 27,1 A NEC 430.32(C) incremental setting: 30,4 A	7.8741.00090 3RB3036-1UB0 12,5-50 A / S2 setting: 32,9 A NEC 430.32(C) incremental setting: 36,9 A	7.8741.00100 3RB3036-1WB0 20-80 A / S2 setting: 40,4 A NEC 430.32(C) incremental setting: 45,3 A	
overload relay soundproofing casing -B24 Siemens	7.8741.00030 3RB3016-1PB0 1,00-4,00 A / S00 setting: 1,43 A NEC 430.32(C) incremental setting: 1,61 A	7.8741.00030 3RB3016-1PB0 1,00-4,00 A / S00 setting: 1,43 A NEC 430.32(C) incremental setting: 1,61 A	7.8741.00030 3RB3016-1PB0 1,00-4,00 A / S00 setting: 1,43 A NEC 430.32(C) incremental setting: 1,61 A	7.8741.00030 3RB3016-1PB0 1,00-4,00 A / S00 setting: 1,43 A NEC 430.32(C) incremental setting: 1,61 A	7.8741.00030 3RB3016-1PB0 1,00-4,00 A / S00 setting: 1,43 A NEC 430.32(C) incremental setting: 1,61 A	
Blower motor -M1 Siemens	894994.0 460 V-D/60 Hz	894995.0 460 V-D/60 Hz	894996.1 (CB) 894997.1 (DB) 460 V-D/60 Hz	894978.1 460 V-D/60 Hz	894979.1 460 V-D/60 Hz	
vent motor soundproofing casing -M4 ebm	895260.00010 W2D250 (1PH/N/GRD) 115 V/60 Hz, 175W 1,55 A	895260.00010 W2D250 (1PH/N/GRD) 115 V/60 Hz, 175W 1,55 A	895260.00010 W2D250 (1PH/N/GRD) 115 V/60 Hz, 175W 1,55 A	895260.00010 W2D250 (1PH/N/GRD) 115 V/60 Hz, 175W 1,55 A	895260.00010 W2D250 (1PH/N/GRD) 115 V/60 Hz, 175W 1,55 A	
contactor -Q1 / -Q2	7.8740.00380 3RT2027-1AK60	7.8740.00400 3RT2035-1AK60	7.8740.00400 3RT2035-1AK60	7.8740.00410 3RT2036-1AK60	7.8740.00430 3RT2038-1AK60	
auxiliary switch	
auxiliary switch	
interference suppressor	7.8740.05140 3RT2926-1CC00	7.8740.05150 3RT2936-1CC00	7.8740.05150 3RT2936-1CC00	7.8740.05150 3RT2936-1CC00	7.8740.05150 3RT2936-1CC00	
terminal	7.3140.05080 3RV2925-5EB	7.3140.05070 3RV2935-5E	7.3140.05070 3RV2935-5E	7.3140.05070 3RV2935-5E	7.3140.05070 3RV2935-5E	
Phase rail	7.6861.0 3RV1915-1AB	7.3140.05270 3RA2933-3FA00	7.3140.05270 3RA2933-3FA00	7.3140.05270 3RA2933-3FA00	7.3140.05270 3RA2933-3FA00	
contactor -Q3	7.8740.00370 3RT2026-1AK60	7.8740.00370 3RT2026-1AK60	7.8740.00380 3RT2027-1AK60	7.8740.00400 3RT2035-1AK60	7.8740.00400 3RT2035-1AK60	
auxiliary switch	
auxiliary switch	
interference suppressor	7.8740.05140 3RT2926-1CC00	7.8740.05140 3RT2926-1CC00	7.8740.05140 3RT2926-1CC00	7.8740.05150 3RT2936-1CC00	7.8740.05150 3RT2936-1CC00	
wye bridge	7.3140.02070 3RT1926-4BA31	7.3140.02070 3RT1926-4BA31	7.3140.02070 3RT1926-4BA31	7.3140.01170 3RT1936-4BA31	7.3140.01170 3RT1936-4BA31	
motor cable -W19.1/19.2	4x10 AWG / 4G6 mm ² 600 V - 90°C	4x10 AWG / 4G6 mm ² 600 V - 90°C	4x8 AWG / 4G10 mm ² 600 V - 90°C	4x6 AWG / 4G16 mm ² 600 V - 90°C	4x6 AWG / 4G16 mm ² 600 V - 90°C	
connection -W11 Phase rail -W13 Phase rail -W14 600 V - 90°C	8 AWG / 10 mm2 Phase rail 14 AWG / 2,5 mm2 600 V - 90°C	8 AWG / 10 mm2 Phase rail 14 AWG / 2,5 mm2 600 V - 90°C	6 AWG / 16 mm2 Phase rail 10 AWG / 6 mm2 600 V - 90°C	4 AWG / 25 mm2 Phase rail Phase rail 600 V - 90°C	2 AWG / 35 mm2 Phase rail Phase rail 600 V - 90°C	
supply terminals U1/V1/W1/GRD -X0: Handling Stripped length X connection	894864.00010 14-4 AWG / 2,5-16 mm ² Wieland fig. 2, Sht. 11 16 mm fig. 1, Sht. 12	894864.00010 14-4 AWG / 2,5-16 mm ² Wieland fig. 2, Sht. 11 16 mm fig. 1, Sht. 12	3x 895314.0 3x 895314.00010 4x 895314.00040 8-1 AWG / 10-50 mm ² Wago fig. 3, Sht. 11 30 mm fig. 2, Sht. 12	3x 895314.0 3x 895314.00010 4x 895314.00040 8-1 AWG / 10-50 mm ² Wago fig. 3, Sht. 11 30 mm fig. 2, Sht. 12	3x 895314.0 3x 895314.00010 4x 895314.00040 8-1 AWG / 10-50 mm ² Wago fig. 3, Sht. 11 30 mm fig. 2, Sht. 12	
supply						

electrical component parts list
460V CB+DB
performance-related components



c	Date	14.12.2020
b	Drawn	M.Zeesh
a	Released	M.Zeesh
c	Change	
	Name	
	Date	

model	performance-related components				page 15 28 Sht
	25 hp EB (18,5 kW)	30 hp EB (22 kW)	40 hp EB+ FB-C (30 kW)	40 hp FB-S (30 kW)	
machine power supply	460 V ±10 %, 60 Hz	460 V ±10 %, 60 Hz	460 V ±10 %, 60 Hz	460 V ±10 %, 60 Hz	= + UXB-STC-U3020.06
overload relay -B21 Siemens	7.8741.00080 3RB3026-1VB0 10-40 A / S0 setting: 16,2 A NEC 430.32(C) incremental setting: 18,2 A	7.8741.00090 3RB3036-1UB0 12,5-50 A / S2 setting: 19,1 A NEC 430.32(C) incremental setting: 21,3 A	7.8741.00090 3RB3036-1UB0 12,5-50 A / S2 setting: 27,1 A NEC 430.32(C) incremental setting: 30,4 A	7.8741.00090 3RB3036-1UB0 12,5-50 A / S2 setting: 27,1 A NEC 430.32(C) incremental setting: 30,4 A	
overload relay soundproofing casing -B24 Siemens	7.8741.00020 3RB3016-1NB0 0,32-1,25 A / S00 setting: 0,57 A NEC 430.32(C) incremental setting: 0,64 A	7.8741.00020 3RB3016-1NB0 0,32-1,25 A / S00 setting: 0,57 A NEC 430.32(C) incremental setting: 0,64 A	7.8741.00020 3RB3016-1NB0 0,32-1,25 A / S00 setting: 0,57 A NEC 430.32(C) incremental setting: 0,64 A	7.8741.00020 3RB3016-1NB0 0,32-1,25 A / S00 setting: 0,57 A NEC 430.32(C) incremental setting: 0,64 A	
Blower motor -M1 Siemens	894994.0 460V-D/60 Hz	894995.0 460V-D/60 Hz	894997.1 460V-D/60 Hz	894997.1 460V-D/60 Hz	
vent motor soundproofing casing -M4 Sodeca/ebm	895040.00040 HC-31-2T / H-I-E 460 V-Y/60 Hz 210W 0,62 A	895040.00040 HC-31-2T / H-I-E 460 V-Y/60 Hz 210W 0,62 A	895040.00040 HC-31-2T / H-I-E 460 V-Y/60 Hz 210W 0,62 A	895426.0 W4D420 (ebm) 460 V-Y/60 Hz 265W 0,62 A	
contactor -Q1 / -Q2	7.8740.00380 3RT2027-1AK60	7.8740.00400 3RT2035-1AK60	7.8740.00400 3RT2035-1AK60	7.8740.00400 3RT2035-1AK60	
auxiliary switch	7.8740.05030 3RH2911-1HA20	7.8740.05030 3RH2911-1HA20	7.8740.05030 3RH2911-1HA20	7.8740.05030 3RH2911-1HA20	
auxiliary switch					
interference suppressor	7.8740.05140 3RT2926-1CC00	7.8740.05150 3RT2936-1CC00	7.8740.05150 3RT2936-1CC00	7.8740.05150 3RT2936-1CC00	
terminal	7.3140.05080 3RV2925-5EB	7.3140.05070 3RV2935-5E	7.3140.05070 3RV2935-5E	7.3140.05070 3RV2935-5E	
Phase rail	7.6861.0 3RV1915-1AB	7.3140.05270 3RA2933-3FA00	7.3140.05270 3RA2933-3FA00	7.3140.05270 3RA2933-3FA00	
contactor -Q3	7.8740.00370 3RT2026-1AK60	7.8740.00380 3RT2027-1AK60	7.8740.00400 3RT2035-1AK60	7.8740.00400 3RT2035-1AK60	
auxiliary switch					
auxiliary switch					
interference suppressor	7.8740.05140 3RT2926-1CC00	7.8740.05140 3RT2926-1CC00	7.8740.05150 3RT2936-1CC00	7.8740.05150 3RT2936-1CC00	
wye bridge	7.3140.02070 3RT1926-4BA31	7.3140.02070 3RT1926-4BA31	7.3140.01170 3RT1936-4BA31	7.3140.01170 3RT1936-4BA31	
motor cable -W19.1/19.2	4x10 AWG / 4G6 mm ² 600 V - 90°C	4x10 AWG / 4G6 mm ² 600 V - 90°C	4x8 AWWG / 4G10 mm ² 600 V - 90°C	4x8 AWWG / 4G10 mm ² 600 V - 90°C	
connection -W11 Phase rail -W13 Phase rail -W14 600 V - 90°C	8 AWG / 10 mm2 Phase rail 14 AWG / 2,5 mm2 600 V - 90°C	8 AWG / 10 mm2 Phase rail 14 AWG / 2,5 mm2 600 V - 90°C	6 AWG / 16 mm2 Phase rail Phase rail 600 V - 90°C	6 AWG / 16 mm2 Phase rail Phase rail 600 V - 90°C	
supply terminals -X0: U1/V1/W1/GRD	894864.00010 14-4 AWG / 2,5-16 mm ² Wieland fig. 2, Sht. 11 16 mm fig. 1, Sht. 12	894864.00010 14-4 AWG / 2,5-16 mm ² Wieland fig. 2, Sht. 11 16 mm fig. 1, Sht. 12	3x 895314.0 3x 895314.00010 4x 895314.00040 8-1 AWG / 10-50 mm ² Wago fig. 3, Sht. 11 30 mm fig. 2, Sht. 12	3x 895314.0 3x 895314.00010 4x 895314.00040 8-1 AWG / 10-50 mm ² Wago fig. 3, Sht. 11 30 mm fig. 2, Sht. 12	
supply					

electrical component parts list
460V EB+FB
performance-related components



c	Date	14.12.2020
b	Drawn	M.Zeeh
a	Released	M.Zeeh
	C Change	
	Name	
	Date	

model	performance-related components				page 16 28 Sht
	50 hp EB+ FB-C (37 kW)	50 hp FB-S (37 kW)	60 hp EB+ FB-C (45 kW)	60 hp FB-S (45 kW)	
machine power supply	460 V ±10 %, 60 Hz	460 V ±10 %, 60 Hz	460 V ±10 %, 60 Hz	460 V ±10 %, 60 Hz	UXB-STC-U3020.06
overload relay -B21 Siemens	7.8741.00090 3RB3036-1UB0 12.5-50 A / S2 setting: 32,9 A NEC 430.32(C) incremental setting: 36,9 A	7.8741.00090 3RB3036-1UB0 12.5-50 A / S2 setting: 32,9 A NEC 430.32(C) incremental setting: 36,9 A	7.8741.00100 3RB3036-1WB0 20-80 A / S2 setting: 40,4 A NEC 430.32(C) incremental setting: 45,3 A	7.8741.00100 3RB3036-1WB0 20-80 A / S2 setting: 40,4 A NEC 430.32(C) incremental setting: 45,3 A	
overload relay soundproofing casing -B24 Siemens	7.8741.00020 3RB3016-1NB0 0,32-1,25 A / S00 setting: 0,57 A NEC 430.32(C) incremental setting: 0,64 A	7.8741.00020 3RB3016-1NB0 0,32-1,25 A / S00 setting: 0,57 A NEC 430.32(C) incremental setting: 0,64 A	7.8741.00020 3RB3016-1NB0 0,32-1,25 A / S00 setting: 0,57 A NEC 430.32(C) incremental setting: 0,64 A	7.8741.00020 3RB3016-1NB0 0,32-1,25 A / S00 setting: 0,57 A NEC 430.32(C) incremental setting: 0,64 A	
Blower motor -M1 Siemens	894978.1 460V-D/60 Hz	894978.1 460V-D/60 Hz	894979.1 460V-D/60 Hz	894979.1 460V-D/60 Hz	
vent motor soundproofing casing -M4 Sodeca/ebm	895040.00040 HC-31-2T / H-I-E 460 V-Y/60 Hz 210W 0,62 A	895426.0 W4D420 (ebm) 460 V-Y/60 Hz 265W 0,62 A	895040.00040 HC-31-2T / H-I-E 460 V-Y/60 Hz 210W 0,62 A	895426.0 W4D420 (ebm) 460 V-Y/60 Hz 265W 0,62 A	
contactor -Q1 / -Q2	7.8740.00410 3RT2036-1AK60	7.8740.00410 3RT2036-1AK60	7.8740.00430 3RT2038-1AK60	7.8740.00430 3RT2038-1AK60	
auxiliary switch	7.8740.05030 3RH2911-1HA20	7.8740.05030 3RH2911-1HA20	7.8740.05030 3RH2911-1HA20	7.8740.05030 3RH2911-1HA20	
auxiliary switch	
interference suppressor	7.8740.05150 3RT2936-1CC00	7.8740.05150 3RT2936-1CC00	7.8740.05150 3RT2936-1CC00	7.8740.05150 3RT2936-1CC00	
terminal	7.3140.05070 3RV2935-5E	7.3140.05070 3RV2935-5E	7.3140.05070 3RV2935-5E	7.3140.05070 3RV2935-5E	
Phase rail	7.3140.05270 3RA2933-3FA00	7.3140.05270 3RA2933-3FA00	7.3140.05270 3RA2933-3FA00	7.3140.05270 3RA2933-3FA00	
contactor -Q3	7.8740.00400 3RT2035-1AK60	7.8740.00400 3RT2035-1AK60	7.8740.00400 3RT2035-1AK60	7.8740.00400 3RT2035-1AK60	
auxiliary switch	
auxiliary switch	
interference suppressor	7.8740.05150 3RT2936-1CC00	7.8740.05150 3RT2936-1CC00	7.8740.05150 3RT2936-1CC00	7.8740.05150 3RT2936-1CC00	
wye bridge	7.3140.01170 3RT1936-4BA31	7.3140.01170 3RT1936-4BA31	7.3140.01170 3RT1936-4BA31	7.3140.01170 3RT1936-4BA31	
motor cable -W19.1/19.2	4x6 AWWG / 4G16 mm ² 600 V - 90°C	4x6 AWWG / 4G16 mm ² 600 V - 90°C	4x6 AWWG / 4G16 mm ² 600 V - 90°C	4x6 AWWG / 4G16 mm ² 600 V - 90°C	
connection -W11 Phase rail -W13 Phase rail -W14 600 V - 90°C	4 AWG / 25 mm ² Phase rail Phase rail 600 V - 90°C	4 AWG / 25 mm ² Phase rail Phase rail 600 V - 90°C	2 AWG / 35 mm ² Phase rail Phase rail 600 V - 90°C	2 AWG / 35 mm ² Phase rail Phase rail 600 V - 90°C	
supply terminals -X0: U1/V1/W1/GRD	3x 895314.0 3x 895314.00010 4x 895314.00040 8-1 AWG / 10-50 mm ² Wago fig. 3, Sht. 11 30 mm	3x 895314.0 3x 895314.00010 4x 895314.00040 8-1 AWG / 10-50 mm ² Wago fig. 3, Sht. 11 30 mm	3x 895314.0 3x 895314.00010 4x 895314.00040 8-1 AWG / 10-50 mm ² Wago fig. 3, Sht. 11 30 mm	3x 895314.0 3x 895314.00010 4x 895314.00040 8-1 AWG / 10-50 mm ² Wago fig. 3, Sht. 11 30 mm	
supply Stripped length X connection	fig. 2, Sht. 12	fig. 2, Sht. 12	fig. 2, Sht. 12	fig. 2, Sht. 12	

electrical component parts list
460V EB+FB
performance-related components



c	Date	14.12.2020
b	Drawn	M.Zeesh
a	Released	M.Zeesh
C Change	Name	
	Date	

model	performance-related components					page 17 28 Sht
	75 hp EB+ FB-C (55 kW)	75 hp FB-S (55 kW)	100 hp EB (75 kW)	100 hp FB-C (75 kW)	100 hp FB-S (75 kW)	
machine power supply	460 V ±10 %, 60 Hz	460 V ±10 %, 60 Hz	460 V ±10 %, 60 Hz	460 V ±10 %, 60 Hz	460 V ±10 %, 60 Hz	= + UXB-STC-U3020.06
overload relay -B21 Siemens	7.8741.00100 3RB3036-1WB0 20-80 A / S2 setting: 47,9 A NEC 430.32(C) incremental setting: 53,7 A	7.8741.00100 3RB3036-1WB0 20-80 A / S2 setting: 47,9 A NEC 430.32(C) incremental setting: 53,7 A	7.8741.00140 3RB3046-1XB0 32-115 A / S3 setting: 64,1 A NEC 430.32(C) incremental setting: 71,8 A	7.8741.00140 3RB3046-1XB0 32-115 A / S3 setting: 64,1 A NEC 430.32(C) incremental setting: 71,8 A	7.8741.00140 3RB3046-1XB0 32-115 A / S3 setting: 65,8 A NEC 430.32(C) incremental setting: 73,7 A	
overload relay soundproofing casing -B24 Siemens	7.8741.00020 3RB3016-1NB0 0,32-1,25 A / S00 setting: 0,57 A NEC 430.32(C) incremental setting: 0,64 A	7.8741.00020 3RB3016-1NB0 0,32-1,25 A / S00 setting: 0,57 A NEC 430.32(C) incremental setting: 0,64 A	7.8741.00020 3RB3016-1NB0 0,32-1,25 A / S00 setting: 0,57 A NEC 430.32(C) incremental setting: 0,64 A	7.8741.00020 3RB3016-1NB0 0,32-1,25 A / S00 setting: 0,57 A NEC 430.32(C) incremental setting: 0,64 A	7.8741.00020 3RB3016-1NB0 0,32-1,25 A / S00 setting: 0,57 A NEC 430.32(C) incremental setting: 0,64 A	
Blower motor -M1 Siemens	894717.1 460V-D/60 Hz	894717.1 460V-D/60 Hz	894719.1 460V-D/60 Hz	894719.1 460V-D/60 Hz	894719.12010 460V-D/60 Hz	
vent motor soundproofing casing -M4 Sodeca/ebm	895040.00040 HC-31-2T / H-I-E 460 V-Y/60 Hz 210W 0,62 A	895426.0 W4D420 (ebm) 460 V-Y/60 Hz 265W 0,62 A	895040.00040 HC-31-2T / H-I-E 460 V-Y/60 Hz 210W 0,62 A	895040.00040 HC-31-2T / H-I-E 460 V-Y/60 Hz 210W 0,62 A	895426.0 W4D420 (ebm) 460 V-Y/60 Hz 265W 0,62 A	
contactor -Q1 / -Q2	7.8740.00410 3RT2036-1AK60	7.8740.00410 3RT2036-1AK60	7.8740.00440 3RT2045-1AK60	7.8740.00450 3RT2046-1AK60	7.8740.00450 3RT2046-1AK60	
auxiliary switch	7.8740.05030 3RH2911-1HA20	7.8740.05030 3RH2911-1HA20	7.8740.05030 3RH2911-1HA20	7.8740.05030 3RH2911-1HA20	7.8740.05030 3RH2911-1HA20	
auxiliary switch	7.8740.05150 3RT2936-1CC00	7.8740.05150 3RT2936-1CC00	7.8740.05170 3RT2946-1CC00	7.8740.05170 3RT2946-1CC00	7.8740.05170 3RT2946-1CC00	
interference suppressor	7.3140.05070 3RV2935-5E	7.3140.05070 3RV2935-5E	---	---	---	
terminal	7.3140.05270 3RA2933-3FA00	7.3140.05270 3RA2933-3FA00	---	---	---	
Phase rail	---	---	---	---	---	
contactor -Q3	7.8740.00400 3RT2035-1AK60	7.8740.00400 3RT2035-1AK60	7.8740.00420 3RT2037-1AK60	7.8740.00440 3RT2045-1AK60	7.8740.00440 3RT2045-1AK60	
auxiliary switch	---	---	---	---	---	
auxiliary switch	---	---	---	---	---	
interference suppressor	7.8740.05150 3RT2936-1CC00	7.8740.05150 3RT2936-1CC00	7.8740.05150 3RT2936-1CC00	7.8740.05170 3RT2946-1CC00	7.8740.05170 3RT2946-1CC00	
wye bridge	7.3140.01170 3RT1936-4BA31	7.3140.01170 3RT1936-4BA31	7.3140.01170 3RT1936-4BA31	7.3140.00940 3RT1946-4BA31	7.3140.00940 3RT1946-4BA31	
motor cable -W19.1/19.2	4x4 AWG / 4G25 mm ² 600 V - 90°C	4x4 AWG / 4G25 mm ² 600 V - 90°C	4x2 AWG / 4G35 mm ² 600 V - 90°C	4x2 AWG / 4G35 mm ² 600 V - 90°C	4x2 AWG / 4G35 mm ² 600 V - 90°C	
connection -W11 -W13 -W14	1 AWG / 50 mm ² Phase rail Phase rail 600 V - 90°C	1 AWG / 50 mm ² Phase rail Phase rail 600 V - 90°C	2 AWG / 35 mm ² 2 AWG / 35 mm ² 8 AWG / 10 mm ² 600 V - 90°C	2 AWG / 35 mm ² 2 AWG / 35 mm ² 8 AWG / 10 mm ² 600 V - 90°C	2 AWG / 35 mm ² 2 AWG / 35 mm ² 8 AWG / 10 mm ² 600 V - 90°C	
supply terminals -X0: U1/V1/W1/PE Handling Stripped length X	3x 894385.0 3x 894385.00010 4x 894385.00040 Wago 4-4/0 AWG / 25-95 mm ² fig. 3, Sht. 11 36 mm	3x 894385.0 3x 894385.00010 4x 894385.00040 Wago 4-4/0 AWG / 25-95 mm ² fig. 3, Sht. 11 36 mm	6x 894385.0 3x 894385.00030 3x 894385.00040 Wago 4-4/0 AWG / 25-95 mm ² fig. 3, Sht. 11 36 mm	6x 894385.0 3x 894385.00030 3x 894385.00040 Wago 4-4/0 AWG / 25-95 mm ² fig. 3, Sht. 11 36 mm	6x 894385.0 3x 894385.00030 3x 894385.00040 Wago 4-4/0 AWG / 25-95 mm ² fig. 3, Sht. 11 36 mm	
PE-rail -X0:PE Torque Stripped length X	---	---	832489.00010 15Nm 25 mm+ Conductor crimp pins	832489.00010 15Nm 25 mm+ Conductor crimp pins	832489.00010 15Nm 25 mm+ Conductor crimp pins	
supply -connection	fig. 2, Sht. 12	fig. 2, Sht. 12	fig. 3, Sht. 13	fig. 3, Sht. 13	fig. 3, Sht. 13	

electrical component parts list

KAESER
KOMPRESSOREN

460V EB+FB
performance-related components

Date 14.12.2020

Drawn M.Zeesh

Released M.Zeesh

C Change

model	performance-related components					18 page 28 Sht
	125 hp FB-C (90 kW)	125 hp FB-S (90 kW)	150 hp FB-C (110 kW)	150 hp FB-S (110 kW)	175 hp FB (132 kW)	
machine power supply	460 V ±10 %, 60 Hz	460 V ±10 %, 60 Hz	460 V ±10 %, 60 Hz	460 V ±10 %, 60 Hz	460 V ±10 %, 60 Hz	= + UXB-STC-U3020.06
overload relay -B21 Siemens	7.6873.00240 3RB2056-1FW2 50-200 A / S6 setting: 78,5 A NEC 430.32(C) incremental setting: 87,9 A	7.6873.00240 3RB2056-1FW2 50-200 A / S6 setting: 77,9 A NEC 430.32(C) incremental setting: 87,3 A	7.6873.00240 3RB2056-1FW2 50-200 A / S6 setting: 98,2 A NEC 430.32(C) incremental setting: 109,9 A	7.6873.00240 3RB2056-1FW2 50-200 A / S6 setting: 92,4 A NEC 430.32(C) incremental setting: 103,5 A	7.6873.00240 3RB2056-1FW2 50-200 A / S6 setting: 114,3 A NEC 430.32(C) incremental setting: 128 A	
overload relay soundproofing casing -B24 Siemens	7.8741.00020 3RB3016-1NB0 0,32-1,25 A / S00 setting: 0,57 A NEC 430.32(C) incremental setting: 0,64 A	7.8741.00020 3RB3016-1NB0 0,32-1,25 A / S00 setting: 0,57 A NEC 430.32(C) incremental setting: 0,64 A	7.8741.00020 3RB3016-1NB0 0,32-1,25 A / S00 setting: 0,57 A NEC 430.32(C) incremental setting: 0,64 A	7.8741.00020 3RB3016-1NB0 0,32-1,25 A / S00 setting: 0,57 A NEC 430.32(C) incremental setting: 0,64 A	7.8741.00020 3RB3016-1NB0 0,32-1,25 A / S00 setting: 0,57 A NEC 430.32(C) incremental setting: 0,64 A	
Blower motor -M1 Siemens	894723.1 460V-D/60 Hz	894722.12010 460V-D/60 Hz	895025.1 460V-D/60 Hz	894724.1 460V-D/60 Hz	894726.1 460V-D/60 Hz	
vent motor soundproofing casing -M4 Sodeca/ebm	895040.00040 HC-31-2T / H-I-E 460 V-Y/60 Hz 210W 0,62 A	895426.0 W4D420 (ebm) 460 V-Y/60 Hz 265W 0,62 A	895040.00040 HC-31-2T / H-I-E 460 V-Y/60 Hz 210W 0,62 A	895426.0 W4D420 (ebm) 460 V-Y/60 Hz 265W 0,62 A	895040.00040 HC-31-2T / H-I-E 460 V-Y/60 Hz 210W 0,62 A	
contactor -Q1 / -Q2	7.3140.02140 3RT1054-1AF36	7.3140.02140 3RT1054-1AF36	7.3140.02140 3RT1054-1AF36	7.3140.02140 3RT1054-1AF36	7.3140.02160 3RT1056-6AF36	
auxiliary switch	7.3140.01690 3RH1921-1CA10	7.3140.01690 3RH1921-1CA10	7.3140.01690 3RH1921-1CA10	7.3140.01690 3RH1921-1CA10	7.3140.01690 3RH1921-1CA10	
auxiliary switch	7.3140.02030 3RH1921-1CA01	7.3140.02030 3RH1921-1CA01	7.3140.02030 3RH1921-1CA01	7.3140.02030 3RH1921-1CA01	7.3140.02030 3RH1921-1CA01	
interference suppressor	7.3140.02020 3RT1956-1CC00	7.3140.02020 3RT1956-1CC00	7.3140.02020 3RT1956-1CC00	7.3140.02020 3RT1956-1CC00	7.3140.02020 3RT1956-1CC00	
terminal	---	---	---	---	---	
Phase rail	---	---	---	---	---	
contactor -Q3	7.8740.00440 3RT2045-1AK60	7.8740.00440 3RT2045-1AK60	7.8740.00450 3RT2046-1AK60	7.8740.00450 3RT2046-1AK60	7.8740.00440 3RT2045-1AK60	
auxiliary switch	---	---	---	---	---	
auxiliary switch	---	---	---	---	---	
interference suppressor	7.8740.05170 3RT2946-1CC00	7.8740.05170 3RT2946-1CC00	7.8740.05170 3RT2946-1CC00	7.8740.05170 3RT2946-1CC00	7.8740.05170 3RT2946-1CC00	
wye bridge	7.3140.00940 3RT1946-4BA31	7.3140.00940 3RT1946-4BA31	7.3140.00940 3RT1946-4BA31	7.3140.00940 3RT1946-4BA31	7.3140.00940 3RT1946-4BA31	
motor cable -W19.1/19.2	4x1 AWG / 4G50 mm ² 600 V - 90°C	4x1 AWG / 4G50 mm ² 600 V - 90°C	4x2/0 AWG / 4G70 mm ² 600 V - 90°C	4x2/0 AWG / 4G70 mm ² 600 V - 90°C	4x3/0 AWG / 4G95 mm ² 600 V - 90°C	
connection -W11 -W13 -W14	1 AWG / 50 mm ² 1 AWG / 50 mm ² 4 AWG / 25 mm ² 600 V - 90°C	1 AWG / 50 mm ² 1 AWG / 50 mm ² 4 AWG / 25 mm ² 600 V - 90°C	2/0 AWG / 70 mm ² 2/0 AWG / 70 mm ² 2 AWG / 35 mm ² 600 V - 90°C	2/0 AWG / 70 mm ² 2/0 AWG / 70 mm ² 2 AWG / 35 mm ² 600 V - 90°C	3/0 AWG / 95 mm ² 3/0 AWG / 95 mm ² 2 AWG / 35 mm ² 600 V - 90°C	
supply terminals -X0: U1/V1/W1 Handling Stripped length X	6x 894385.0 3x 894385.00030 3x 894385.00040 Wago 4-4/0 AWG / 25-95 mm ² fig. 3, Sht. 11 36 mm	6x 894385.0 3x 894385.00030 3x 894385.00040 Wago 4-4/0 AWG / 25-95 mm ² fig. 3, Sht. 11 36 mm	6x 894385.0 3x 894385.00030 3x 894385.00040 Wago 4-4/0 AWG / 25-95 mm ² fig. 3, Sht. 11 36 mm	6x 894385.0 3x 894385.00030 3x 894385.00040 Wago 4-4/0 AWG / 25-95 mm ² fig. 3, Sht. 11 36 mm	6x 895545.0 3x 895545.00030 3x 895545.00040 Wago (50-185 mm ²) 1 AWG - 350 MCM fig. 3, Sht. 11 45 mm	
PE-rail -X0:PE Torque Stripped length X	832489.00010 15Nm 25 mm+ Conductor crimp pins	832489.00010 15Nm 25 mm+ Conductor crimp pins	832489.00010 15Nm 25 mm+ Conductor crimp pins	832489.00010 15Nm 25 mm+ Conductor crimp pins	832489.00010 15Nm 25 mm+ Conductor crimp pins	
supply -connection	fig. 3, Sht. 13	fig. 3, Sht. 13	fig. 3, Sht. 13	fig. 3, Sht. 13	fig. 3, Sht. 13	

electrical component parts list
460V FB
performance-related components



Date	14.12.2020
Drawn	M.Zeesh
Released	M.Zeesh

C Change		Date		Name	
----------	--	------	--	------	--

model	performance-related components					page 19 28 Sht
	5 hp BB (4 kW)	7,5 hp BB+ CB+DB (5,5 kW)	10 hp BB+ CB+DB (7,5 kW)	15 hp BB+ CB+DB (11 kW)	20 hp BB+ CB+DB (15 kW)	
machine power supply	575 V ±10 %, 60 Hz	575 V ±10 %, 60 Hz	575 V ±10 %, 60 Hz	575 V ±10 %, 60 Hz	575 V ±10 %, 60 Hz	= + UXB-STC-U3020.06
overload relay -B21 Siemens	7.8741.00120 3RB3026-1PB0 1-4 A / S0 setting: 2,6 A NEC 430.32(C) incremental setting: 2,9 A	7.8741.00060 3RB3026-1SB0 3-12 A / S0 setting: 3,7 A NEC 430.32(C) incremental setting: 4,2 A	7.8741.00060 3RB3026-1SB0 3-12 A / S0 setting: 4,9 A NEC 430.32(C) incremental setting: 5,5 A	7.8741.00070 3RB3026-1QB0 6-25 A / S0 setting: 7,5 A NEC 430.32(C) incremental setting: 8,5 A	7.8741.00070 3RB3026-1QB0 6-25 A / S0 setting: 10,2 A NEC 430.32(C) incremental setting: 11,5 A	
overload relay soundproofing casing -B24 Siemens	7.8741.00030 3RB3016-1PB0 1,00-4,00 A / S00 setting: 1,43 A NEC 430.32(C) incremental setting: 1,61 A	7.8741.00030 3RB3016-1PB0 1,00-4,00 A / S00 setting: 1,43 A NEC 430.32(C) incremental setting: 1,61 A	7.8741.00030 3RB3016-1PB0 1,00-4,00 A / S00 setting: 1,43 A NEC 430.32(C) incremental setting: 1,61 A	7.8741.00030 3RB3016-1PB0 1,00-4,00 A / S00 setting: 1,43 A NEC 430.32(C) incremental setting: 1,61 A	7.8741.00030 3RB3016-1PB0 1,00-4,00 A / S00 setting: 1,43 A NEC 430.32(C) incremental setting: 1,61 A	
Blower motor -M1 Siemens	894969.00500 575V-D/60 Hz	894970.00500 575V-D/60 Hz	894971.00500 575V-D/60 Hz	894972.00500 575V-D/60 Hz	894973.00500 575V-D/60 Hz	
vent motor soundproofing casing -M4 ebm	895260.00010 W2D250 (1PH/N/GRD) 115 V/60 Hz, 175W 1,55 A	895260.00010 W2D250 (1PH/N/GRD) 115 V/60 Hz, 175W 1,55 A	895260.00010 W2D250 (1PH/N/GRD) 115 V/60 Hz, 175W 1,55 A	895260.00010 W2D250 (1PH/N/GRD) 115 V/60 Hz, 175W 1,55 A	895260.00010 W2D250 (1PH/N/GRD) 115 V/60 Hz, 175W 1,55 A	
contactor -Q1 / -Q2	7.8740.00340 3RT2023-1AK60	7.8740.00340 3RT2023-1AK60	7.8740.00350 3RT2024-1AK60	7.8740.00360 3RT2025-1AK60	7.8740.00380 3RT2027-1AK60	
auxiliary switch	7.8740.05030 3RH2911-1HA20	7.8740.05030 3RH2911-1HA20	7.8740.05030 3RH2911-1HA20	7.8740.05030 3RH2911-1HA20	7.8740.05030 3RH2911-1HA20	
auxiliary switch	
interference suppressor	7.8740.05140 3RT2926-1CC00	7.8740.05140 3RT2926-1CC00	7.8740.05140 3RT2926-1CC00	7.8740.05140 3RT2926-1CC00	7.8740.05140 3RT2926-1CC00	
terminal	7.3140.05080 3RV2925-5EB	7.3140.05080 3RV2925-5EB	7.3140.05080 3RV2925-5EB	7.3140.05080 3RV2925-5EB	7.3140.05080 3RV2925-5EB	
Phase rail	7.6861.0 3RV1915-1AB	7.6861.0 3RV1915-1AB	7.6861.0 3RV1915-1AB	7.6861.0 3RV1915-1AB	7.6861.0 3RV1915-1AB	
contactor -Q3	7.8740.00310 3RT2016-1AK61	7.8740.00310 3RT2016-1AK61	7.8740.00310 3RT2016-1AK61	7.8740.00310 3RT2016-1AK61	7.8740.00360 3RT2025-1AK60	
auxiliary switch	7.8740.05010 3RH2911-1HA11	7.8740.05010 3RH2911-1HA11	7.8740.05010 3RH2911-1HA11	7.8740.05010 3RH2911-1HA11	.	
auxiliary switch	
interference suppressor	7.8740.05130 3RT2916-1CC00	7.8740.05130 3RT2916-1CC00	7.8740.05130 3RT2916-1CC00	7.8740.05130 3RT2916-1CC00	7.8740.05140 3RT2926-1CC00	
wye bridge	7.3140.05030 3RT1916-4BA31	7.3140.05030 3RT1916-4BA31	7.3140.05030 3RT1916-4BA31	7.3140.05030 3RT1916-4BA31	7.3140.02070 3RT1926-4BA31	
motor cable -W19.1/19.2	4x14 AWG / 4G2,5 mm ² 600 V - 90°C	4x14 AWG / 4G2,5 mm ² 600 V - 90°C	4x14 AWG / 4G2,5 mm ² 600 V - 90°C	4x14 AWG / 4G2,5 mm ² 600 V - 90°C	4x12 AWG / 4G4 mm ² 600 V - 90°C	
connection -W11 -W13 -W14	14 AWG / 2,5 mm ² Phase rail 14 AWG / 2,5 mm ² 600 V - 90°C	14 AWG / 2,5 mm ² Phase rail 14 AWG / 2,5 mm ² 600 V - 90°C	14 AWG / 2,5 mm ² Phase rail 14 AWG / 2,5 mm ² 600 V - 90°C	10 AWG / 6 mm ² Phase rail 14 AWG / 2,5 mm ² 600 V - 90°C	10 AWG / 6 mm ² Phase rail Phase rail 600 V - 90°C	
supply terminals -X0: U1/V1/W1/GRD	894864.00010	894864.00010	894864.00010	894864.00010	894864.00010	
Handling Stripped length X connection	14-4 AWG / 2,5-16 mm ² Wieland fig. 2, Sht. 11 16 mm fig. 1, Sht. 12	14-4 AWG / 2,5-16 mm ² Wieland fig. 2, Sht. 11 16 mm fig. 1, Sht. 12	14-4 AWG / 2,5-16 mm ² Wieland fig. 2, Sht. 11 16 mm fig. 1, Sht. 12	14-4 AWG / 2,5-16 mm ² Wieland fig. 2, Sht. 11 16 mm fig. 1, Sht. 12	14-4 AWG / 2,5-16 mm ² Wieland fig. 2, Sht. 11 16 mm fig. 1, Sht. 12	
supply						

electrical component parts list
575V BB+CB+DB
performance-related components



c	Date	14.12.2020
b	Drawn	M.Zeesh
a	Released	M.Zeesh
C	Change	
	Name	
	Date	

model	performance-related components					page 20 28 Sht
	25 hp CB+ DB (18,5 kW)	30 hp CB+ DB (22 kW)	40 hp CB+ DB (30 kW)	50 hp DB (37 kW)	60 hp DB (45 kW)	
machine power supply	575 V ±10 %, 60 Hz	575 V ±10 %, 60 Hz	575 V ±10 %, 60 Hz	575 V ±10 %, 60 Hz	575 V ±10 %, 60 Hz	= + UXB-STC-U3020.06
overload relay -B21 Siemens	7.8741.00070 3RB3026-1QB0 6-25 A / S0 setting: 11,9 A NEC 430.32(C) incremental setting: 13,5 A	7.8741.00090 3RB3036-1UB0 12,5-50 A / S2 setting: 14,2 A NEC 430.32(C) incremental setting: 16,1 A	7.8741.00090 3RB3036-1UB0 12,5-50 A / S2 setting: 21,8 A NEC 430.32(C) incremental setting: 24,6 A	7.8741.00090 3RB3036-1UB0 12,5-50 A / S2 setting: 26,6 A NEC 430.32(C) incremental setting: 30 A	7.8741.00090 3RB3036-1UB0 12,5-50 A / S2 setting: 32,9 A NEC 430.32(C) incremental setting: 37,2 A	
overload relay soundproofing casing -B24 Siemens	7.8741.00030 3RB3016-1PB0 1,00-4,00 A / S00 setting: 1,43 A NEC 430.32(C) incremental setting: 1,61 A	7.8741.00030 3RB3016-1PB0 1,00-4,00 A / S00 setting: 1,43 A NEC 430.32(C) incremental setting: 1,61 A	7.8741.00030 3RB3016-1PB0 1,00-4,00 A / S00 setting: 1,43 A NEC 430.32(C) incremental setting: 1,61 A	7.8741.00030 3RB3016-1PB0 1,00-4,00 A / S00 setting: 1,43 A NEC 430.32(C) incremental setting: 1,61 A	7.8741.00030 3RB3016-1PB0 1,00-4,00 A / S00 setting: 1,43 A NEC 430.32(C) incremental setting: 1,61 A	
Blower motor -M1 Siemens	8949743.00500 575 V-D/60 Hz	894975.00500 575 V-D/60 Hz	894976.10500 (CB) 894977.10500 (DB) 575 V-D/60 Hz	894978.10500 575 V-D/60 Hz	894979.10500 575 V-D/60 Hz	
vent motor soundproofing casing -M4 ebm	895260.00010 W2D250 (1PH/N/GRD) 115 V/60 Hz, 175W 1,55 A	895260.00010 W2D250 (1PH/N/GRD) 115 V/60 Hz, 175W 1,55 A	895260.00010 W2D250 (1PH/N/GRD) 115 V/60 Hz, 175W 1,55 A	895260.00010 W2D250 (1PH/N/GRD) 115 V/60 Hz, 175W 1,55 A	895260.00010 W2D250 (1PH/N/GRD) 115 V/60 Hz, 175W 1,55 A	
contactor -Q1 / -Q2	7.8740.00380 3RT2027-1AK60	7.8740.00400 3RT2035-1AK60	7.8740.00400 3RT2035-1AK60	7.8740.00400 3RT2035-1AK60	7.8740.00410 3RT2036-1AK60	
auxiliary switch .	7.8740.05030 3RH2911-1HA20	7.8740.05030 3RH2911-1HA20	7.8740.05030 3RH2911-1HA20	7.8740.05030 3RH2911-1HA20	7.8740.05030 3RH2911-1HA20	
auxiliary switch .						
interference suppressor .	7.8740.05140 3RT2926-1CC00	7.8740.05150 3RT2936-1CC00	7.8740.05150 3RT2936-1CC00	7.8740.05150 3RT2936-1CC00	7.8740.05150 3RT2936-1CC00	
terminal .	7.3140.05080 3RV2925-5EB	7.3140.05070 3RV2935-5E	7.3140.05070 3RV2935-5E	7.3140.05070 3RV2935-5E	7.3140.05070 3RV2935-5E	
Phase rail .	7.6861.0 3RV1915-1AB	7.3140.02120 3RV1935-1A	7.3140.05270 3RA2933-3FA00	7.3140.05270 3RA2933-3FA00	7.3140.05270 3RA2933-3FA00	
contactor -Q3	7.8740.00360 3RT2025-1AK60	7.8740.00370 3RT2026-1AK60	7.8740.00380 3RT2027-1AK60	7.8740.00390 3RT2028-1AK60	7.8740.00400 3RT2035-1AK60	
auxiliary switch .						
auxiliary switch .						
interference suppressor .	7.8740.05140 3RT2926-1CC00	7.8740.05140 3RT2926-1CC00	7.8740.05140 3RT2926-1CC00	7.8740.05140 3RT2926-1CC00	7.8740.05150 3RT2936-1CC00	
wye bridge .	7.3140.02070 3RT1926-4BA31	7.3140.02070 3RT1926-4BA31	7.3140.02070 3RT1926-4BA31	7.3140.02070 3RT1926-4BA31	7.3140.01170 3RT1936-4BA31	
motor cable -W19.1/19.2	4x12 AWG / 4G4 mm ² 600 V - 90°C	4x10 AWG / 4G6 mm ² 600 V - 90°C	4x8 AWG / 4G10 mm ² 600 V - 90°C	4x8 AWG / 4G10 mm ² 600 V - 90°C	4x6 AWG / 4G16 mm ² 600 V - 90°C	
connection -W11 Phase rail -W13 Phase rail -W14 Phase rail	10 AWG / 6 mm2 600 V - 90°C	8 AWG / 10 mm2 Phase rail 10 AWG / 6 mm2 600 V - 90°C	8 AWG / 10 mm2 Phase rail 10 AWG / 6 mm2 600 V - 90°C	6 AWG / 16 mm2 Phase rail 10 AWG / 6 mm2 600 V - 90°C	4 AWG / 25 mm2 Phase rail Phase rail 600 V - 90°C	
supply terminals -X0: U1/V1/W1/GRD	894864.00010 14-4 AWG / 2,5-16 mm ² Wieland fig. 2, Sht. 11 16 mm fig. 1, Sht. 12	894864.00010 14-4 AWG / 2,5-16 mm ² Wieland fig. 2, Sht. 11 16 mm fig. 1, Sht. 12	894864.00010 14-4 AWG / 2,5-16 mm ² Wieland fig. 2, Sht. 11 16 mm fig. 1, Sht. 12	3x 895314.0 3x 895314.00010 4x 895314.00040 8-1 AWG / 10-50 mm ² Wago fig. 3, Sht. 11 30 mm fig. 2, Sht. 12	3x 895314.0 3x 895314.00010 4x 895314.00040 8-1 AWG / 10-50 mm ² Wago fig. 3, Sht. 11 30 mm fig. 2, Sht. 12	
supply Handling Stripped length X connection						

electrical component parts list
575V CB+DB
performance-related components



c	Date	14.12.2020
b	Drawn	M.Zeesh
a	Released	M.Zeesh
c	Change	
	Name	
	Date	

model	performance-related components				page 21 28 Sht
	25 hp EB (18,5 kW)	30 hp EB (22 kW)	40 hp EB+ FB-C (30 kW)	40 hp FB-S (30 kW)	
machine power supply	575 V ±10 %, 60 Hz	575 V ±10 %, 60 Hz	575 V ±10 %, 60 Hz	575 V ±10 %, 60 Hz	= + UXB-STC-U3020.06
overload relay -B21 Siemens	7.8741.00070 3RB3026-1QB0 6-25 A / S0 setting: 11,9 A NEC 430.32(C) incremental setting: 13,5 A	7.8741.00090 3RB3036-1UB0 12,5-50 A / S2 setting: 14,2 A NEC 430.32(C) incremental setting: 16,1 A	7.8741.00090 3RB3036-1UB0 12,5-50 A / S2 setting: 22,0 A NEC 430.32(C) incremental setting: 24,9 A	7.8741.00090 3RB3036-1UB0 12,5-50 A / S2 setting: 22,0 A NEC 430.32(C) incremental setting: 24,9 A	
overload relay soundproofing casing -B24 Siemens	7.8741.00020 3RB3016-1NB0 0,32-1,25 A / S00 setting: 0,36 A NEC 430.32(C) incremental setting: 0,41 A	7.8741.00020 3RB3016-1NB0 0,32-1,25 A / S00 setting: 0,36 A NEC 430.32(C) incremental setting: 0,41 A	7.8741.00020 3RB3016-1NB0 0,32-1,25 A / S00 setting: 0,36 A NEC 430.32(C) incremental setting: 0,41 A	7.8741.00020 3RB3016-1NB0 0,32-1,25 A / S00 setting: 0,57 A NEC 430.32(C) incremental setting: 0,64 A	electrical component parts list 575V EB+FB performance-related components
Blower motor -M1 Siemens	8949743.00500 575V-D/60 Hz	894975.00500 575V-D/60 Hz	894977.10500 575V-D/60 Hz	894977.10500 575V-D/60 Hz	
vent motor soundproofing casing -M4 Sodeca/ebm	895040.00010 HC-31-2T / H-I-E 575 V-Y/60 Hz 180W 0,39 A	895040.00010 HC-31-2T / H-I-E 575 V-Y/60 Hz 180W 0,39 A	895040.00010 HC-31-2T / H-I-E 575 V-Y/60 Hz 180W 0,39 A	895426.0 W4D420 (ebm) 460 V-Y/60 Hz 265W 0,62 A	
auto-transformer -T12 Block	---	---	---	7.5452.00340 AT3/x 558 VA 575 V/460 V	
fuse -12FU Gould	---	---	---	(3x) - 7.3161.00390 ATQR 1 A - 600 V - class CC	
fuse socket -12FU Wöhner	---	---	---	3-pole - 7.3320.00060 class CC-Ambus Easy Switch	
contactor -Q1 / -Q2	7.8740.00380 3RT2027-1AK60	7.8740.00400 3RT2035-1AK60	7.8740.00400 3RT2035-1AK60	7.8740.00400 3RT2035-1AK60	KAESER KOMPRESSOREN
auxiliary switch	7.8740.05030 3RH2911-1HA20	7.8740.05030 3RH2911-1HA20	7.8740.05030 3RH2911-1HA20	7.8740.05030 3RH2911-1HA20	
auxiliary switch	7.8740.05140 3RT2926-1CC00	7.8740.05150 3RT2936-1CC00	7.8740.05150 3RT2936-1CC00	7.8740.05150 3RT2936-1CC00	
interference suppressor	7.3140.05080 3RV2925-5EB	7.3140.05070 3RV2935-5E	7.3140.05070 3RV2935-5E	7.3140.05070 3RV2935-5E	
terminal	7.6861.0 3RV1915-1AB	7.3140.05270 3RA2933-3FA00	7.3140.05270 3RA2933-3FA00	7.3140.05270 3RA2933-3FA00	
Phase rail	---	---	---	---	
contactor -Q3	7.8740.00360 3RT2025-1AK60	7.8740.00370 3RT2026-1AK60	7.8740.00380 3RT2027-1AK60	7.8740.00380 3RT2027-1AK60	
auxiliary switch	---	---	---	---	
auxiliary switch	---	---	---	---	
interference suppressor	7.8740.05140 3RT2926-1CC00	7.8740.05140 3RT2926-1CC00	7.8740.05140 3RT2926-1CC00	7.8740.05140 3RT2926-1CC00	
wye bridge	7.3140.02070 3RT1926-4BA31	7.3140.02070 3RT1926-4BA31	7.3140.02070 3RT1926-4BA31	7.3140.02070 3RT1926-4BA31	
motor cable -W19.1/19.2	4x12 AWG / 4G4 mm ² 600 V - 90°C	4x10 AWG / 4G6 mm ² 600 V - 90°C	4x8 AWWG / 4G10 mm ² 600 V - 90°C	4x8 AWWG / 4G10 mm ² 600 V - 90°C	14.12.2020 M.Zeesh M.Zeesh
connection -W11 -W13 -W14	10 AWG / 6 mm ² Phase rail Phase rail 600 V - 90°C	8 AWG / 10 mm ² Phase rail 14 AWG / 2,5 mm ² 600 V - 90°C	6 AWG / 16 mm ² Phase rail 10 AWG / 6 mm ² 600 V - 90°C	6 AWG / 16 mm ² Phase rail 10 AWG / 6 mm ² 600 V - 90°C	Date Drawn Released Name
Fortsetzung: nächstes Blatt					Date C Change

model	performance-related components				=	+	page 22 28 Sht
	25 hp EB (18,5 kW)	30 hp EB (22 kW)	40 hp EB+ FB-C (30 kW)	40 hp FB-S (30 kW)			
machine power supply	575 V ±10 %, 60 Hz	575 V ±10 %, 60 Hz	575 V ±10 %, 60 Hz	575 V ±10 %, 60 Hz			
supply terminals -X0: U1/V1/W1/GRD	894864.00010	894864.00010	3x 895314.0 3x 895314.00010 4x 895314.00040	3x 895314.0 3x 895314.00010 4x 895314.00040			
Handling Stripped length X connection	14-4 AWG / 2,5-16 mm ² Wieland fig. 2, Sht. 11 16 mm fig. 1, Sht. 12	14-4 AWG / 2,5-16 mm ² Wieland fig. 2, Sht. 11 16 mm fig. 1, Sht. 12	8-1 AWG / 10-50 mm ² Wago fig. 3, Sht. 11 30 mm fig. 2, Sht. 12	8-1 AWG / 10-50 mm ² Wago fig. 3, Sht. 11 30 mm fig. 2, Sht. 12			
supply							
<div style="display: flex; justify-content: space-between; align-items: center;"> <div style="writing-mode: vertical-rl; transform: rotate(180deg);"> electrical component parts list 575V EB+FB performance-related components </div> <div style="text-align: center;">  </div> </div>							
c	Date	14.12.2020					
b	Drawn	M.Zeesh					
a	Released	M.Zeesh					
C Change	Name						
	Date						

model	performance-related components				page 23 28 Sht
	50 hp EB+ FB-C (37 kW)	50 hp FB-S (37 kW)	60 hp EB+ FB-C (45 kW)	60 hp FB-S (45 kW)	
machine power supply	575 V ±10 %, 60 Hz	575 V ±10 %, 60 Hz	575 V ±10 %, 60 Hz	575 V ±10 %, 60 Hz	= + UXB-STC-U3020.06
overload relay -B21 3RB3036-1UB0 12,5-50 A / S2 setting: 26,6 A NEC 430.32(C) incremental setting: 30 A Siemens	7.8741.00090 3RB3036-1UB0 12,5-50 A / S2 setting: 26,6 A NEC 430.32(C) incremental setting: 30 A	7.8741.00090 3RB3036-1UB0 12,5-50 A / S2 setting: 26,6 A NEC 430.32(C) incremental setting: 30 A	7.8741.00090 3RB3036-1UB0 12,5-50 A / S2 setting: 32,9 A NEC 430.32(C) incremental setting: 37,2 A	7.8741.00090 3RB3036-1UB0 12,5-50 A / S2 setting: 32,9 A NEC 430.32(C) incremental setting: 37,2 A	
overload relay soundproofing casing -B24 3RB3016-1NB0 0,32-1,25 A / S00 setting: 0,36 A NEC 430.32(C) incremental setting: 0,41 A Siemens	7.8741.00020 3RB3016-1NB0 0,32-1,25 A / S00 setting: 0,36 A NEC 430.32(C) incremental setting: 0,41 A	7.8741.00020 3RB3016-1NB0 0,32-1,25 A / S00 setting: 0,57 A NEC 430.32(C) incremental setting: 0,64 A	7.8741.00020 3RB3016-1NB0 0,32-1,25 A / S00 setting: 0,36 A NEC 430.32(C) incremental setting: 0,41 A	7.8741.00020 3RB3016-1NB0 0,32-1,25 A / S00 setting: 0,57 A NEC 430.32(C) incremental setting: 0,64 A	electrical component parts list 575V EB+FB performance-related components
Blower motor -M1 Siemens	894978.10500 575V-D/60 Hz	894978.10500 575V-D/60 Hz	894979.10500 575V-D/60 Hz	894979.10500 575V-D/60 Hz	
vent motor soundproofing casing -M4 Sodeca/ebm	895040.00010 HC-31-2T / H-I-E 575 V-Y/60 Hz 180W 0,39 A	895426.0 W4D420 (ebm) 460 V-Y/60 Hz 265W 0,62 A	895040.00010 HC-31-2T / H-I-E 575 V-Y/60 Hz 180W 0,39 A	895426.0 W4D420 (ebm) 460 V-Y/60 Hz 265W 0,62 A	
auto-transformer -T12 Block	--- --- ---	7.5452.00340 AT3/x 558 VA 575 V/460 V	--- --- ---	7.5452.00340 AT3/x 558 VA 575 V/460 V	
fuse -12FU Gould	--- ---	(3x) - 7.3161.00390 ATQR 1 A - 600 V - class CC	--- ---	(3x) - 7.3161.00390 ATQR 1 A - 600 V - class CC	
fuse socket -12FU Wöhner	--- ---	3-pole - 7.3320.00060 class CC-Ambus Easy Switch	--- ---	3-pole - 7.3320.00060 class CC-Ambus Easy Switch	KAESER KOMPRESSOREN
contactor -Q1 / -Q2 auxiliary switch auxiliary switch interference suppressor terminal Phase rail Siemens	7.8740.00400 3RT2035-1AK60 7.8740.05030 3RH2911-1HA20 7.8740.05150 3RT2936-1CC00 7.3140.05070 3RV2935-5E 7.3140.05270 3RA2933-3FA00	7.8740.00400 3RT2035-1AK60 7.8740.05030 3RH2911-1HA20 7.8740.05150 3RT2936-1CC00 7.3140.05070 3RV2935-5E 7.3140.05270 3RA2933-3FA00	7.8740.00410 3RT2036-1AK60 7.8740.05030 3RH2911-1HA20 7.8740.05150 3RT2936-1CC00 7.3140.05070 3RV2935-5E 7.3140.05270 3RA2933-3FA00	7.8740.00410 3RT2036-1AK60 7.8740.05030 3RH2911-1HA20 7.8740.05150 3RT2936-1CC00 7.3140.05070 3RV2935-5E 7.3140.05270 3RA2933-3FA00	
contactor -Q3 auxiliary switch auxiliary switch interference suppressor wye bridge Siemens	7.8740.00400 3RT2035-1AK60 7.8740.05150 3RT2936-1CC00 7.3140.01170 3RT1936-4BA31	7.8740.00400 3RT2035-1AK60 7.8740.05150 3RT2936-1CC00 7.3140.01170 3RT1936-4BA31	7.8740.00400 3RT2035-1AK60 7.8740.05150 3RT2936-1CC00 7.3140.01170 3RT1936-4BA31	7.8740.00400 3RT2035-1AK60 7.8740.05150 3RT2936-1CC00 7.3140.01170 3RT1936-4BA31	
motor cable -W19.1/19.2	4x8 AWWG / 4G10 mm ² 600 V - 90°C	4x8 AWWG / 4G10 mm ² 600 V - 90°C	4x8 AWWG / 4G10 mm ² 600 V - 90°C	4x8 AWWG / 4G10 mm ² 600 V - 90°C	14.12.2020 M.Zeesh M.Zeesh
connection -W11 -W13 -W14	6 AWG / 16 mm ² Phase rail Phase rail 600 V - 90°C	6 AWG / 16 mm ² Phase rail Phase rail 600 V - 90°C	4 AWG / 25 mm ² Phase rail Phase rail 600 V - 90°C	4 AWG / 25 mm ² Phase rail Phase rail 600 V - 90°C	Date Drawn Released Name
Fortsetzung: nächstes Blatt					Date C Change

model	performance-related components				page 24 28 Sht
	50 hp EB+ FB-C (37 kW)	50 hp FB-S (37 kW)	60 hp EB+ FB-C (45 kW)	60 hp FB-S (45 kW)	
machine power supply	575 V ±10 %, 60 Hz	575 V ±10 %, 60 Hz	575 V ±10 %, 60 Hz	575 V ±10 %, 60 Hz	= + UXB-STC-U3020.06
supply terminals -X0: U1/V1/W1/GRD	3x 895314.0 3x 895314.00010 4x 895314.00040 8-1 AWG / 10-50 mm ² Wago	3x 895314.0 3x 895314.00010 4x 895314.00040 8-1 AWG / 10-50 mm ² Wago	3x 895314.0 3x 895314.00010 4x 895314.00040 8-1 AWG / 10-50 mm ² Wago	3x 895314.0 3x 895314.00010 4x 895314.00040 8-1 AWG / 10-50 mm ² Wago	
Handling Stripped length X	fig. 3, Sht. 11 30 mm	fig. 3, Sht. 11 30 mm	fig. 3, Sht. 11 30 mm	fig. 3, Sht. 11 30 mm	electrical component parts list 575V EB+FB performance-related components
supply connection	fig. 2, Sht. 12	fig. 2, Sht. 12	fig. 2, Sht. 12	fig. 2, Sht. 12	



Date	14.12.2020
Drawn	M.Zeesh
Released	M.Zeesh

C Change	Date	Name

model	performance-related components					page 25 28 Sht
	75 hp EB+ FB-C (55 kW)	75 hp FB-S (55 kW)	100 hp EB-C (75 kW)	100 hp FB-C (75 kW)	100 hp FB-S (75 kW)	
machine power supply	575 V ±10 %, 60 Hz	575 V ±10 %, 60 Hz	575 V ±10 %, 60 Hz	575 V ±10 %, 60 Hz	575 V ±10 %, 60 Hz	= + UXB-STC-U3020.06
overload relay -B21 Siemens	7.8741.00100 3RB3036-1WB0 20-80 A / S2 setting: 39,1 A NEC 430.32(C) incremental setting: 44,2 A	7.8741.00100 3RB3036-1WB0 20-80 A / S2 setting: 39,1 A NEC 430.32(C) incremental setting: 44,2 A	7.8741.00100 3RB3036-1WB0 20-80 A / S2 setting: 53,6 A NEC 430.32(C) incremental setting: 60,6 A	7.8741.00100 3RB3036-1WB0 20-80 A / S2 setting: 53,6 A NEC 430.32(C) incremental setting: 60,6 A	7.8741.00100 3RB3036-1WB0 20-80 A / S2 setting: 53,6 A NEC 430.32(C) incremental setting: 60,6 A	
overload relay soundproofing casing -B24 Siemens	7.8741.00020 3RB3016-1NB0 0,32-1,25 A / S00 setting: 0,36 A NEC 430.32(C) incremental setting: 0,41 A	7.8741.00020 3RB3016-1NB0 0,32-1,25 A / S00 setting: 0,57 A NEC 430.32(C) incremental setting: 0,64 A	7.8741.00020 3RB3016-1NB0 0,32-1,25 A / S00 setting: 0,36 A NEC 430.32(C) incremental setting: 0,41 A	7.8741.00020 3RB3016-1NB0 0,32-1,25 A / S00 setting: 0,36 A NEC 430.32(C) incremental setting: 0,41 A	7.8741.00020 3RB3016-1NB0 0,32-1,25 A / S00 setting: 0,57 A NEC 430.32(C) incremental setting: 0,64 A	electrical component parts list 575V EB+FB performance-related components
Blower motor -M1 Siemens	894717.10500 575V-D/60 Hz	894717.10500 575V-D/60 Hz	894719.10500 575V-D/60 Hz	894719.10500 575V-D/60 Hz	894719.10500 575V-D/60 Hz	
vent motor soundproofing casing -M4 Sodeca/ebm	895040.00010 HC-31-2T / H-I-E 575 V-Y/60 Hz 180W 0,39 A	895426.0 W4D420 (ebm) 460 V-Y/60 Hz 265W 0,62 A	895040.00010 HC-31-2T / H-I-E 575 V-Y/60 Hz 180W 0,39 A	895040.00010 HC-31-2T / H-I-E 575 V-Y/60 Hz 180W 0,39 A	895426.0 W4D420 (ebm) 460 V-Y/60 Hz 265W 0,62 A	
auto-transformer -T12 Block	---	7.5452.00340 AT3/x 558 VA 575 V/460 V	---	---	7.5452.00340 AT3/x 558 VA 575 V/460 V	
fuse -12FU Gould	---	(3x) - 7.3161.00390 ATQR 1 A - 600 V - class CC	---	---	(3x) - 7.3161.00390 ATQR 1 A - 600 V - class CC	
fuse socket -12FU Wöhner	---	3-pole - 7.3320.00060 class CC-Ambus Easy Switch	---	---	3-pole - 7.3320.00060 class CC-Ambus Easy Switch	
contactor -Q1 / -Q2	7.8740.00400 3RT2035-1AK60	7.8740.00400 3RT2035-1AK60	7.8740.00430 3RT2038-1AK60	7.8740.00430 3RT2038-1AK60	7.8740.00430 3RT2038-1AK60	KAESER KOMPRESSOREN
auxiliary switch	7.8740.05030 3RH2911-1HA20	7.8740.05030 3RH2911-1HA20	7.8740.05030 3RH2911-1HA20	7.8740.05030 3RH2911-1HA20	7.8740.05030 3RH2911-1HA20	
auxiliary switch	7.8740.05150 3RT2936-1CC00	7.8740.05150 3RT2936-1CC00	7.8740.05150 3RT2936-1CC00	7.8740.05150 3RT2936-1CC00	7.8740.05150 3RT2936-1CC00	
interference suppressor	7.3140.05070 3RV2935-5E	7.3140.05070 3RV2935-5E	7.3140.05070 3RV2935-5E	7.3140.05070 3RV2935-5E	7.3140.05070 3RV2935-5E	
terminal	7.3140.05270 3RA2933-3FA00	7.3140.05270 3RA2933-3FA00	7.3140.05270 3RA2933-3FA00	7.3140.05270 3RA2933-3FA00	7.3140.05270 3RA2933-3FA00	
Phase rail	---	---	---	---	---	
contactor -Q3	7.8740.00400 3RT2035-1AK60	7.8740.00400 3RT2035-1AK60	7.8740.00400 3RT2035-1AK60	7.8740.00400 3RT2035-1AK60	7.8740.00400 3RT2035-1AK60	
auxiliary switch	7.8740.05150 3RT2936-1CC00	7.8740.05150 3RT2936-1CC00	7.8740.05150 3RT2936-1CC00	7.8740.05150 3RT2936-1CC00	7.8740.05150 3RT2936-1CC00	
auxiliary switch	7.3140.01170 3RT1936-4BA31	7.3140.01170 3RT1936-4BA31	7.3140.01170 3RT1936-4BA31	7.3140.01170 3RT1936-4BA31	7.3140.01170 3RT1936-4BA31	
interference suppressor	---	---	---	---	---	
wye bridge	---	---	---	---	---	
motor cable -W19.1/19.2	4x6 AWWG / 4G16 mm² 600 V - 90°C	4x6 AWWG / 4G16 mm² 600 V - 90°C	4x4 AWG / 4G25 mm² 600 V - 90°C	4x4 AWG / 4G25 mm² 600 V - 90°C	4x4 AWG / 4G25 mm² 600 V - 90°C	14.12.2020 M.Zeesh M.Zeesh
connection -W11 -W13 -W14	2 AWG / 35 mm² Phase rail 600 V - 90°C	2 AWG / 35 mm² Phase rail 600 V - 90°C	1 AWG/50 mm² Phase rail 600 V - 90°C	1 AWG/50 mm² Phase rail 600 V - 90°C	1 AWG/50 mm² Phase rail 600 V - 90°C	Date Drawn Released Name
Fortsetzung: nächstes Blatt						Date C Change

model	performance-related components					page 26 28 Sht
	75 hp EB+ FB-C (55 kW)	75 hp FB-S (55 kW)	100 hp EB-C (75 kW)	100 hp FB-C (75 kW)	100 hp FB-S (75 kW)	
machine power supply	575 V ±10 %, 60 Hz	575 V ±10 %, 60 Hz	575 V ±10 %, 60 Hz	575 V ±10 %, 60 Hz	575 V ±10 %, 60 Hz	= + UXB-STC-U3020.06
supply terminals -X0: U1/V1/W1/PE Handling Torque Stripped length X	3x 895314.0 3x 895314.00010 4x 895314.00040 8-1 AWG / 10-50 mm ² Wago fig. 3, Sht. 11 --- 30 mm	3x 895314.0 3x 895314.00010 4x 895314.00040 8-1 AWG / 10-50 mm ² Wago fig. 3, Sht. 11 --- 30 mm	6x 894385.0 (Wago) 3x 894385.00030 3x 894385.00040 4-4/0 AWG / 25-95 mm ² Wago fig. 3, Sht. 11 --- 36 mm	3x 894385.0 3x 894385.00010 4x 894385.00040 4-4/0 AWG / 25-95 mm ² Wago fig. 3, Sht. 11 --- 36 mm	3x 894385.0 3x 894385.00010 4x 894385.00040 4-4/0 AWG / 25-95 mm ² Wago fig. 3, Sht. 11 --- 36 mm	
PE-rail Torque Stripped length X	---	---	832489.00010 (PE) 133lb-in 25 mm + Conductor crimp pins fig. 3, Sht. 13	---	---	electrical component parts list 575V EB+FB performance-related components
supply connection	fig. 2, Sht. 12	fig. 2, Sht. 12	fig. 3, Sht. 13	fig. 2, Sht. 12	fig. 2, Sht. 12	



c	Date	14.12.2020
b	Drawn	M.Zeesh
a	Released	M.Zeesh
C Change	Date	
	Name	

model	performance-related components					page 27 28 Sht												
	125 hp FB-C (90 kW)	125 hp FB-S (90 kW)	150 hp FB-C (110 kW)	150 hp FB-S (110 kW)	175 hp FB (132 kW)													
machine power supply	575 V ±10 %, 60 Hz	575 V ±10 %, 60 Hz	575 V ±10 %, 60 Hz	575 V ±10 %, 60 Hz	575 V ±10 %, 60 Hz	= + UXB-STC-U3020.06												
overload relay -B21 Siemens	7.6873.00240 3RB2056-1FW2 50-200 A / S6 setting: 67,1 A NEC 430.32(C) incremental setting: 75,9 A	7.6873.00240 3RB2056-1FW2 50-200 A / S6 setting: 63,3 A NEC 430.32(C) incremental setting: 71,6 A	7.6873.00240 3RB2056-1FW2 50-200 A / S6 setting: 79,7 A NEC 430.32(C) incremental setting: 90,1 A	7.6873.00240 3RB2056-1FW2 50-200 A / S6 setting: 78,6 A NEC 430.32(C) incremental setting: 88,9 A	7.6873.00240 3RB2056-1FW2 50-200 A / S6 setting: 95,6 A NEC 430.32(C) incremental setting: 108,1 A													
overload relay soundproofing casing -B24 Siemens	7.8741.00020 3RB3016-1NB0 0,32-1,25 A / S00 setting: 0,36 A NEC 430.32(C) incremental setting: 0,41 A	7.8741.00020 3RB3016-1NB0 0,32-1,25 A / S00 setting: 0,57 A NEC 430.32(C) incremental setting: 0,64 A	7.8741.00020 3RB3016-1NB0 0,32-1,25 A / S00 setting: 0,36 A NEC 430.32(C) incremental setting: 0,41 A	7.8741.00020 3RB3016-1NB0 0,32-1,25 A / S00 setting: 0,57 A NEC 430.32(C) incremental setting: 0,64 A	7.8741.00020 3RB3016-1NB0 0,32-1,25 A / S00 setting: 0,36 A NEC 430.32(C) incremental setting: 0,41 A	electrical component parts list 575V FB performance-related components												
Blower motor -M1 Siemens	894723.10500 575V-D/60 Hz	894722.10500 575V-D/60 Hz	895025.10500 575V-D/60 Hz	894724.10500 575V-D/60 Hz	894726.10500 575V-D/60 Hz													
vent motor soundproofing casing -M4 Sodeca/ebm	895040.00010 HC-31-2T / H-I-E 575 V-Y/60 Hz 180W 0,39 A	895426.0 W4D420 (ebm) 460 V-Y/60 Hz 265W 0,62 A	895040.00010 HC-31-2T / H-I-E 575 V-Y/60 Hz 180W 0,39 A	895426.0 W4D420 (ebm) 460 V-Y/60 Hz 265W 0,62 A	895040.00010 HC-31-2T / H-I-E 575 V-Y/60 Hz 180W 0,39 A													
auto-transformer -T12 Block	---	7.5452.00340 AT3/x 558 VA 575 V/460 V	---	7.5452.00340 AT3/x 558 VA 575 V/460 V	---													
fuse -12FU Gould	---	(3x) - 7.3161.00390 ATQR 1 A - 600 V - class CC	---	(3x) - 7.3161.00390 ATQR 1 A - 600 V - class CC	---													
fuse socket -12FU Wöhner	---	3-pole (2x) - 7.3320.00060 class CC-Ambus Easy Switch	---	3-pole (2x) - 7.3320.00060 class CC-Ambus Easy Switch	---													
contactor -Q1 / -Q2	7.3140.02140 3RT1054-1AF36	7.3140.02140 3RT1054-1AF36	7.3140.02140 3RT1054-1AF36	7.3140.02140 3RT1054-1AF36	7.3140.02140 3RT1054-1AF36	KAESER KOMPRESSOREN												
auxiliary switch	7.3140.01690 3RH1921-1CA10	7.3140.01690 3RH1921-1CA10	7.3140.01690 3RH1921-1CA10	7.3140.01690 3RH1921-1CA10	7.3140.01690 3RH1921-1CA10													
auxiliary switch	7.3140.02030 3RH1921-1CA01	7.3140.02030 3RH1921-1CA01	7.3140.02030 3RH1921-1CA01	7.3140.02030 3RH1921-1CA01	7.3140.02030 3RH1921-1CA01													
interference suppressor	7.3140.02020 3RT1956-1CC00	7.3140.02020 3RT1956-1CC00	7.3140.02020 3RT1956-1CC00	7.3140.02020 3RT1956-1CC00	7.3140.02020 3RT1956-1CC00													
terminal	---	---	---	---	---													
Phase rail	---	---	---	---	---													
contactor -Q3	7.8740.00410 3RT2036-1AK60	7.8740.00410 3RT2036-1AK60	7.8740.00440 3RT2045-1AK60	7.8740.00440 3RT2045-1AK60	7.8740.00440 3RT2045-1AK60													
auxiliary switch	---	---	---	---	---													
auxiliary switch	---	---	---	---	---													
interference suppressor	7.8740.05150 3RT2936-1CC00	7.8740.05150 3RT2936-1CC00	7.8740.05170 3RT2946-1CC00	7.8740.05170 3RT2946-1CC00	7.8740.05170 3RT2946-1CC00													
wye bridge	7.3140.01170 3RT1936-4BA31	7.3140.01170 3RT1936-4BA31	7.3140.00940 3RT1946-4BA31	7.3140.00940 3RT1946-4BA31	7.3140.00940 3RT1946-4BA31													
motor cable -W19.1/19.2	4x2 AWG / 4G35 mm ² 600 V - 90°C	4x2 AWG / 4G35 mm ² 600 V - 90°C	4x1 AWG / 4G50 mm ² 600 V - 90°C	4x1 AWG / 4G50 mm ² 600 V - 90°C	4x2/0 AWG / 4G70 mm ² 600 V - 90°C													
connection -W11 -W13 -W14	2 AWG / 35 mm ² 2 AWG / 35 mm ² 8 AWG / 10 mm ² 600 V - 90°C	2 AWG / 35 mm ² 2 AWG / 35 mm ² 8 AWG / 10 mm ² 600 V - 90°C	1 AWG / 50 mm ² 1 AWG / 50 mm ² 6 AWG / 16 mm ² 600 V - 90°C	1 AWG / 50 mm ² 1 AWG / 50 mm ² 6 AWG / 16 mm ² 600 V - 90°C	1 AWG / 50 mm ² 1 AWG / 50 mm ² 4 AWG / 25 mm ² 600 V - 90°C													
Fortsetzung: nächstes Blatt						<table border="1"> <tr> <td>c</td> <td>Date</td> <td>14.12.2020</td> </tr> <tr> <td>b</td> <td>Drawn</td> <td>M.Zeesh</td> </tr> <tr> <td>a</td> <td>Released</td> <td>M.Zeesh</td> </tr> <tr> <td>C</td> <td>Change</td> <td></td> </tr> </table>	c	Date	14.12.2020	b	Drawn	M.Zeesh	a	Released	M.Zeesh	C	Change	
c	Date	14.12.2020																
b	Drawn	M.Zeesh																
a	Released	M.Zeesh																
C	Change																	

model	performance-related components					page 28 28 Sht																									
	125 hp FB-C (90 kW)	125 hp FB-S (90 kW)	150 hp FB-C (110 kW)	150 hp FB-S (110 kW)	175 hp FB (132 kW)																										
machine power supply	575 V ±10 %, 60 Hz	575 V ±10 %, 60 Hz	575 V ±10 %, 60 Hz	575 V ±10 %, 60 Hz	575 V ±10 %, 60 Hz	= + UXB-STC-U3020.06																									
supply terminals -X0: U1/V1/W1 Handling Stripped length X	6x 894385.0 3x 894385.00030 3x 894385.00040 Wago 4-4/0 AWG / 25-95 mm² fig. 3, Sht. 11 36 mm	6x 894385.0 3x 894385.00030 3x 894385.00040 Wago 4-4/0 AWG / 25-95 mm² fig. 3, Sht. 11 36 mm	6x 894385.0 3x 894385.00030 3x 894385.00040 Wago 4-4/0 AWG / 25-95 mm² fig. 3, Sht. 11 36 mm	6x 894385.0 3x 894385.00030 3x 894385.00040 Wago 4-4/0 AWG / 25-95 mm² fig. 3, Sht. 11 36 mm	6x 894385.0 3x 894385.00030 3x 894385.00040 Wago 4-4/0 AWG / 25-95 mm² fig. 3, Sht. 11 36 mm																										
PE-rail -X0:PE Torque Stripped length X	832489.00010 15Nm 25 mm+ Conductor crimp pins	832489.00010 15Nm 25 mm+ Conductor crimp pins	832489.00010 15Nm 25 mm+ Conductor crimp pins	832489.00010 15Nm 25 mm+ Conductor crimp pins	832489.00010 15Nm 25 mm+ Conductor crimp pins																										
supply -connection	fig. 3, Sht. 13	fig. 3, Sht. 13	fig. 3, Sht. 13	fig. 3, Sht. 13	fig. 3, Sht. 13																										
<div style="text-align: right; padding-right: 10px;"> electrical component parts list 575V FB performance-related components </div> <div style="text-align: center; border: 1px solid black; padding: 5px; margin: 5px 0;"> KAESER KOMPRESSOREN </div>							<table border="1" style="width: 100%; border-collapse: collapse;"> <tr> <td style="width: 20%;"></td> <td style="width: 20%;">Date</td> <td style="width: 20%;">14.12.2020</td> <td style="width: 20%;"></td> </tr> <tr> <td></td> <td>Drawn</td> <td>M.Zeeh</td> <td></td> </tr> <tr> <td></td> <td>Released</td> <td>M.Zeeh</td> <td></td> </tr> <tr> <td></td> <td>Name</td> <td></td> <td></td> </tr> <tr> <td></td> <td>Date</td> <td></td> <td></td> </tr> <tr> <td>C Change</td> <td></td> <td></td> <td></td> </tr> </table>		Date	14.12.2020			Drawn	M.Zeeh			Released	M.Zeeh			Name				Date			C Change			
									Date	14.12.2020																					
								Drawn	M.Zeeh																						
								Released	M.Zeeh																						
	Name																														
	Date																														
C Change																															

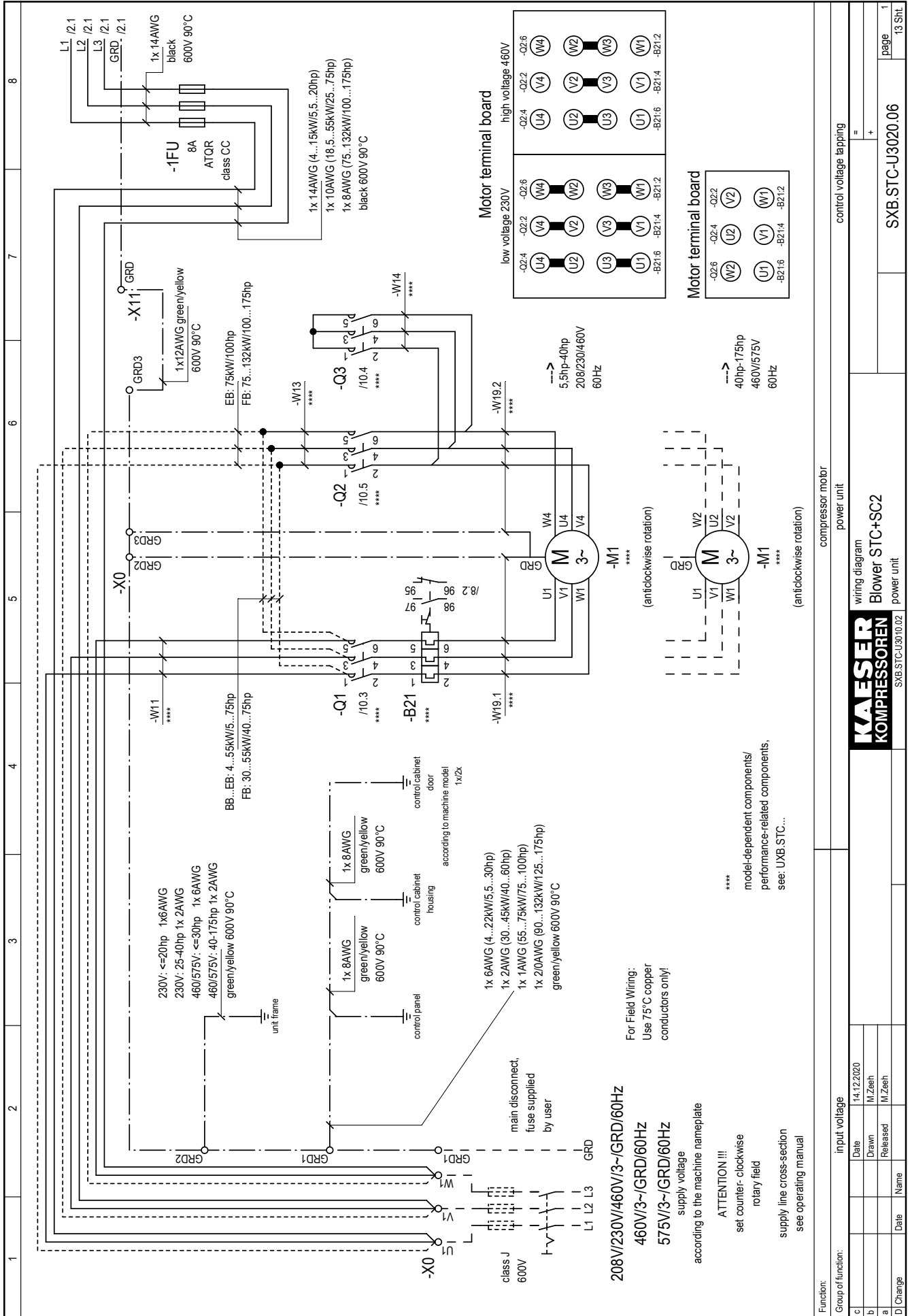

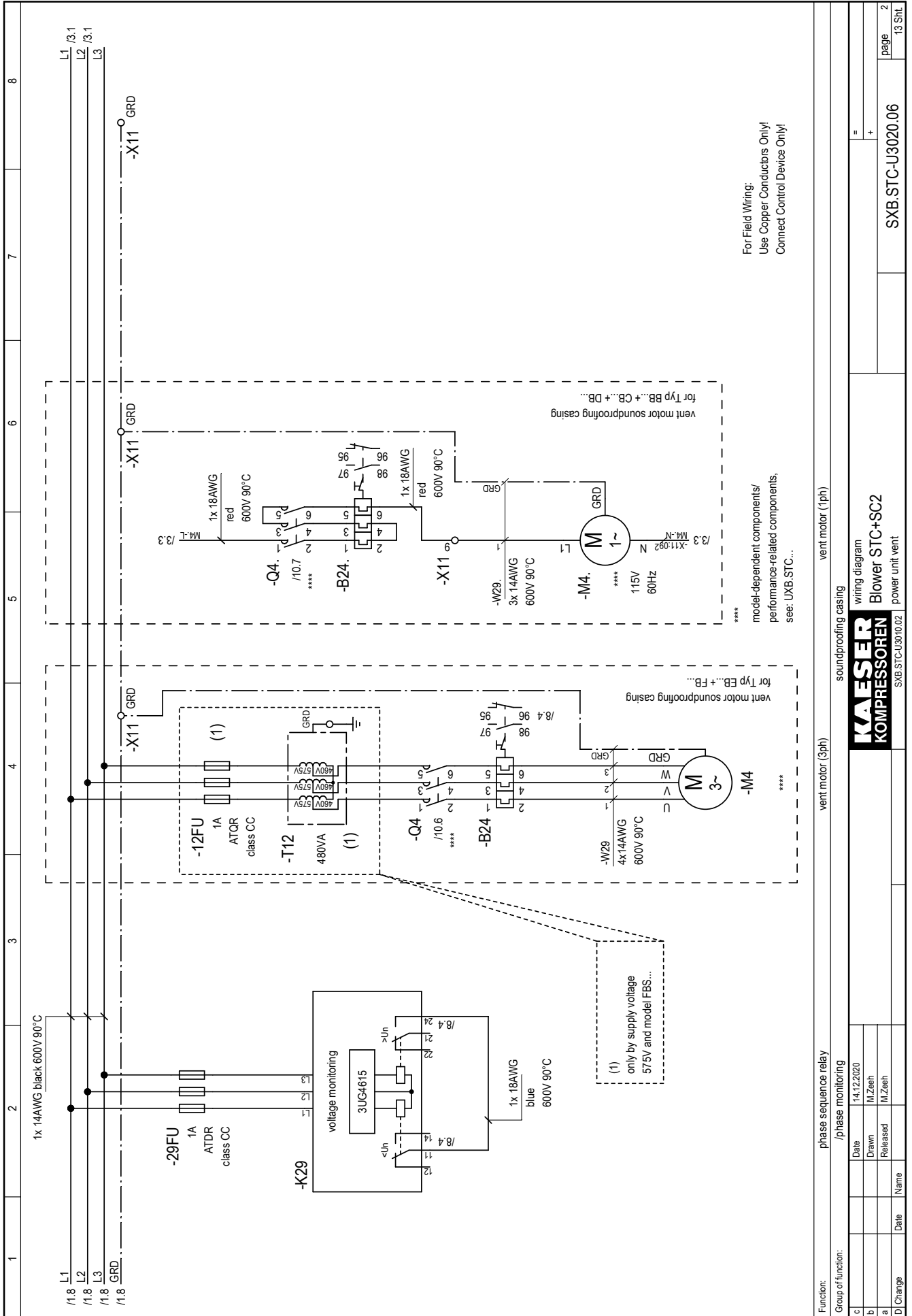

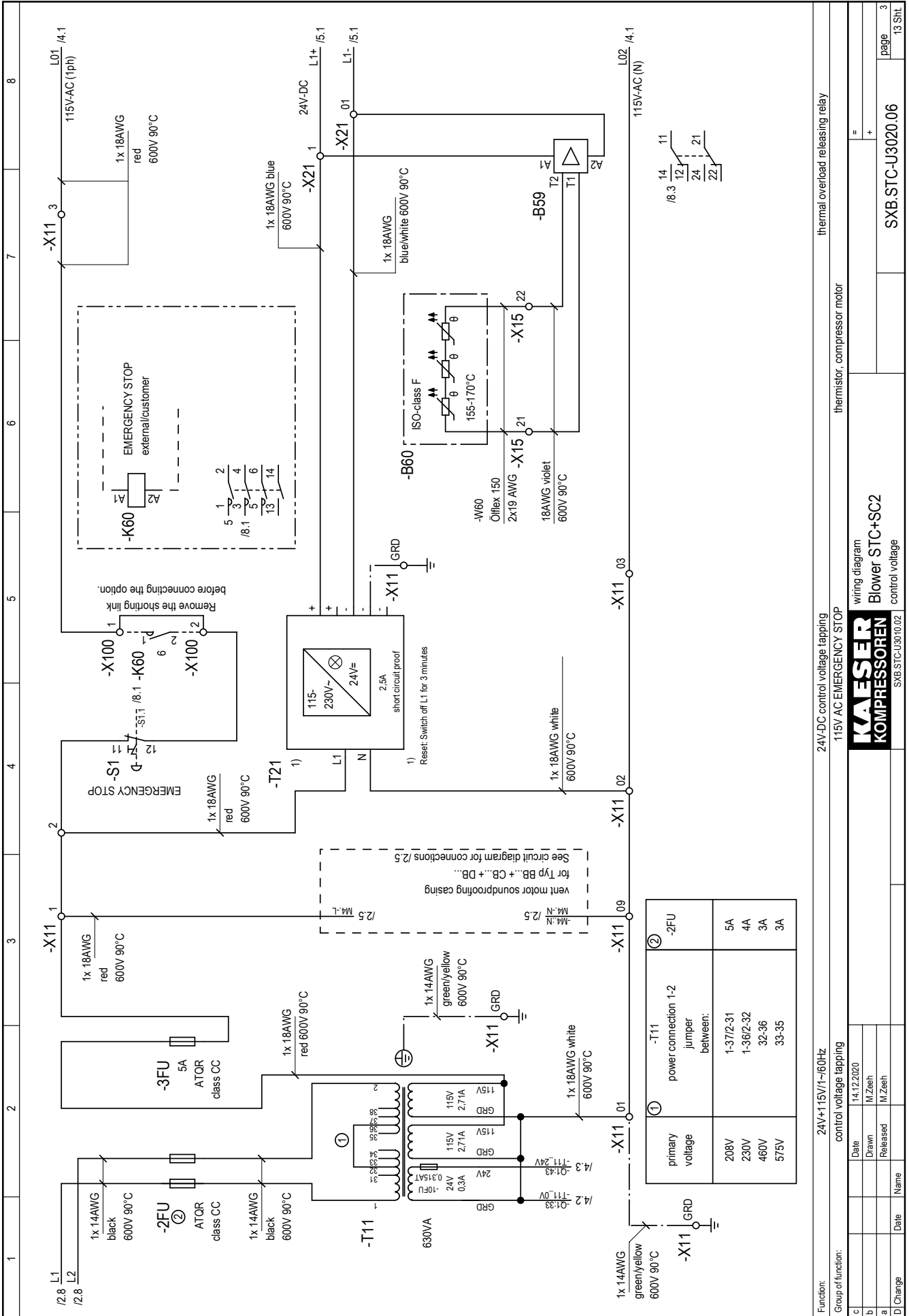

Function:		24V+115V/1~60Hz	
Group of function:		control voltage tapping	
		24V-DC control voltage tapping	
		115V AC EMERGENCY STOP	
		thermistor, compressor motor	
		thermal overload releasing relay	
c	Date	14.12.2020	
b	Drawn	M.Zeeh	
a	Released	M.Zeeh	
D	Change	Date	Name
		wiring diagram	
		Blower STC+SC2	
		control voltage	
		SX8.STC-U3010.02	
		SX8.STC-U3020.06	
		page	
		3	
		13 Sht	

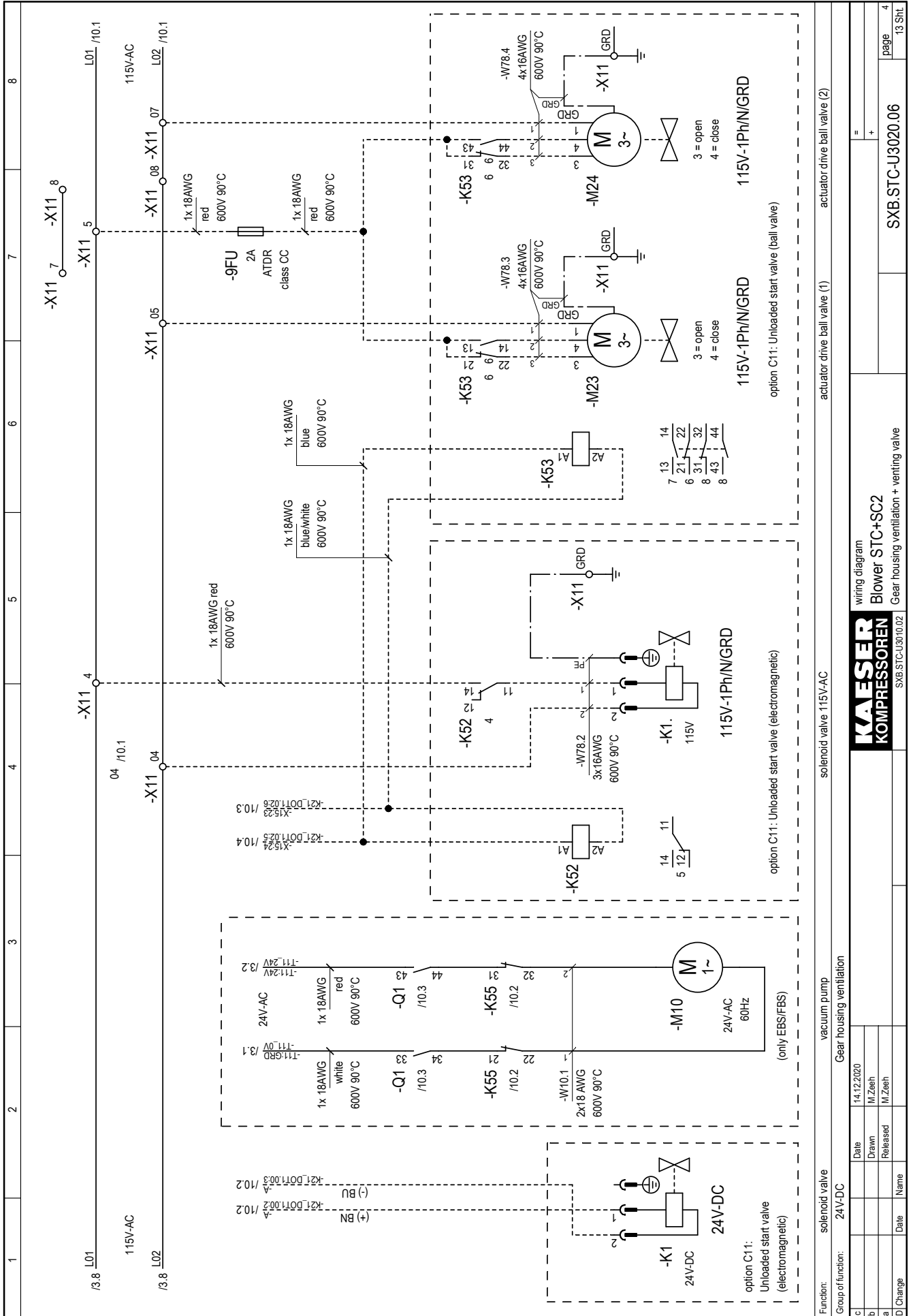

wiring diagram		SX.B.STC-U3010.02	
Blower STC+SC2		SX.B.STC-U3020.06	
Gear housing ventilation + venting valve		page 4	
13 Sht		13 Sht	

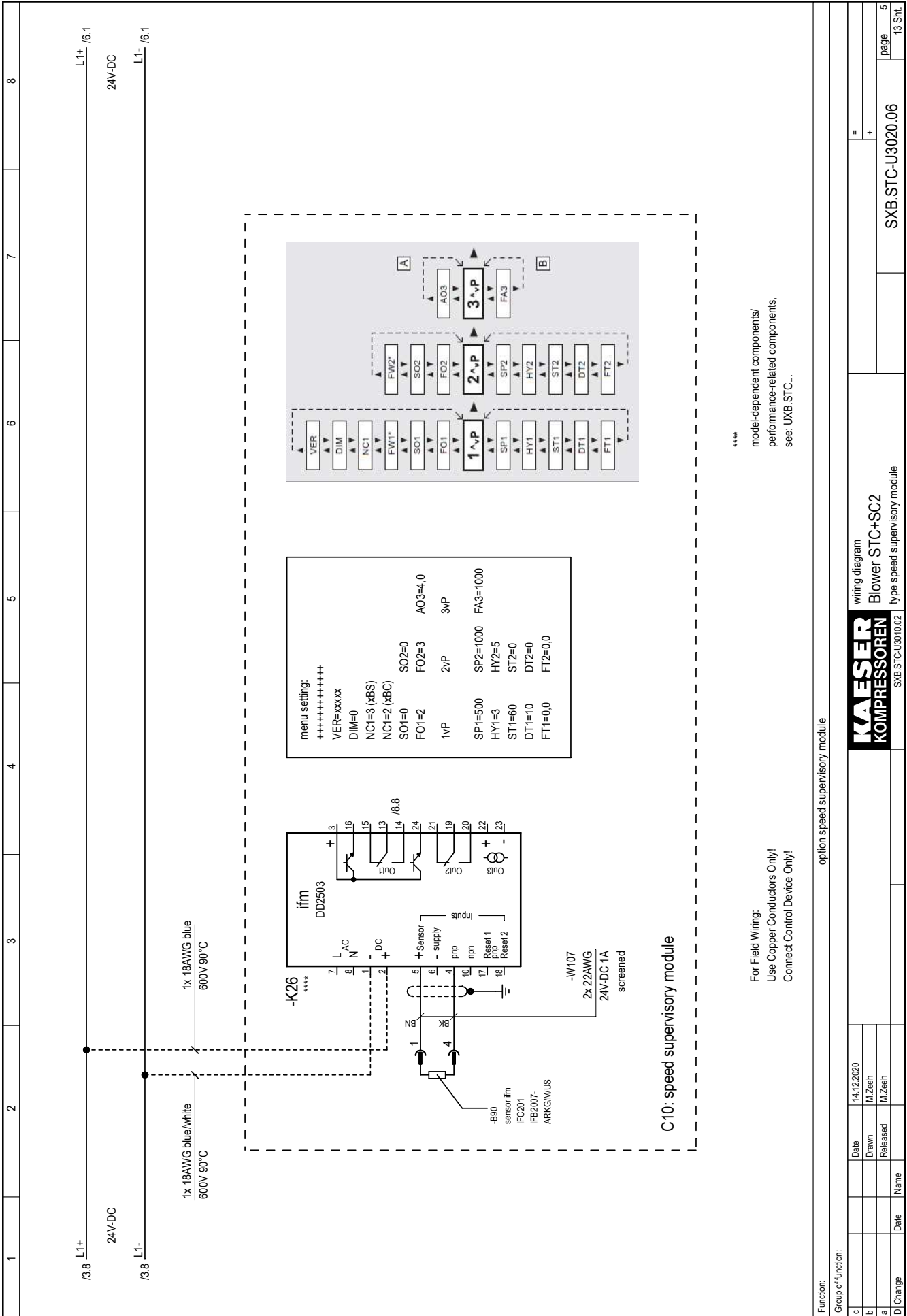

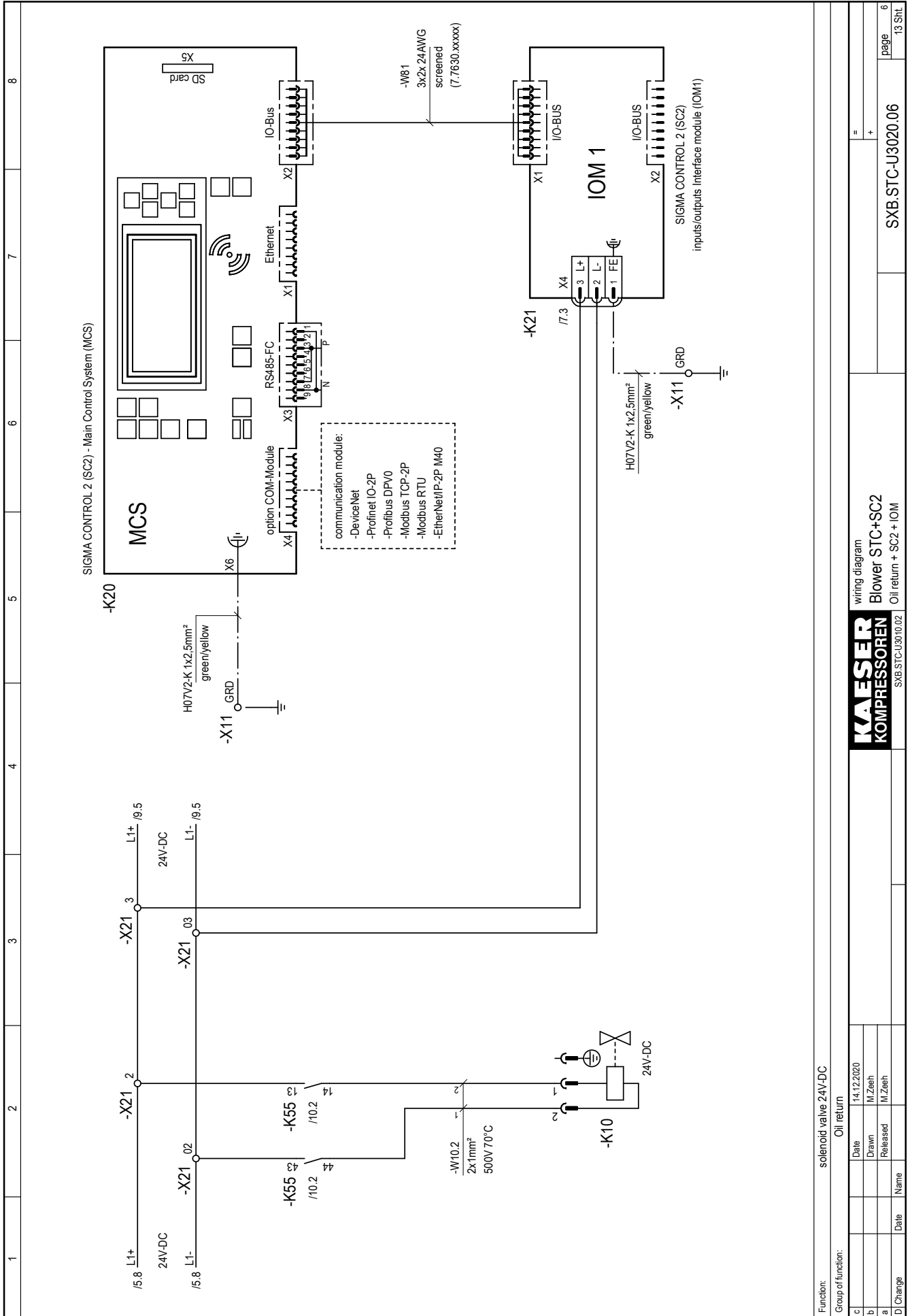

Function: solenoid valve 24V-DC
Oil return

Group of function:	Date	Drawn	Released
c	14.12.2020	M.Zeesh	M.Zeesh
b			
a			
D	Date	Name	

KAESER
KOMPRESSOREN

wiring diagram
Blower STC+SC2
Oil return + SC2 + IOM

SXB.STC-U3010.02

SXB.STC-U3020.06

page 6
13 Sht

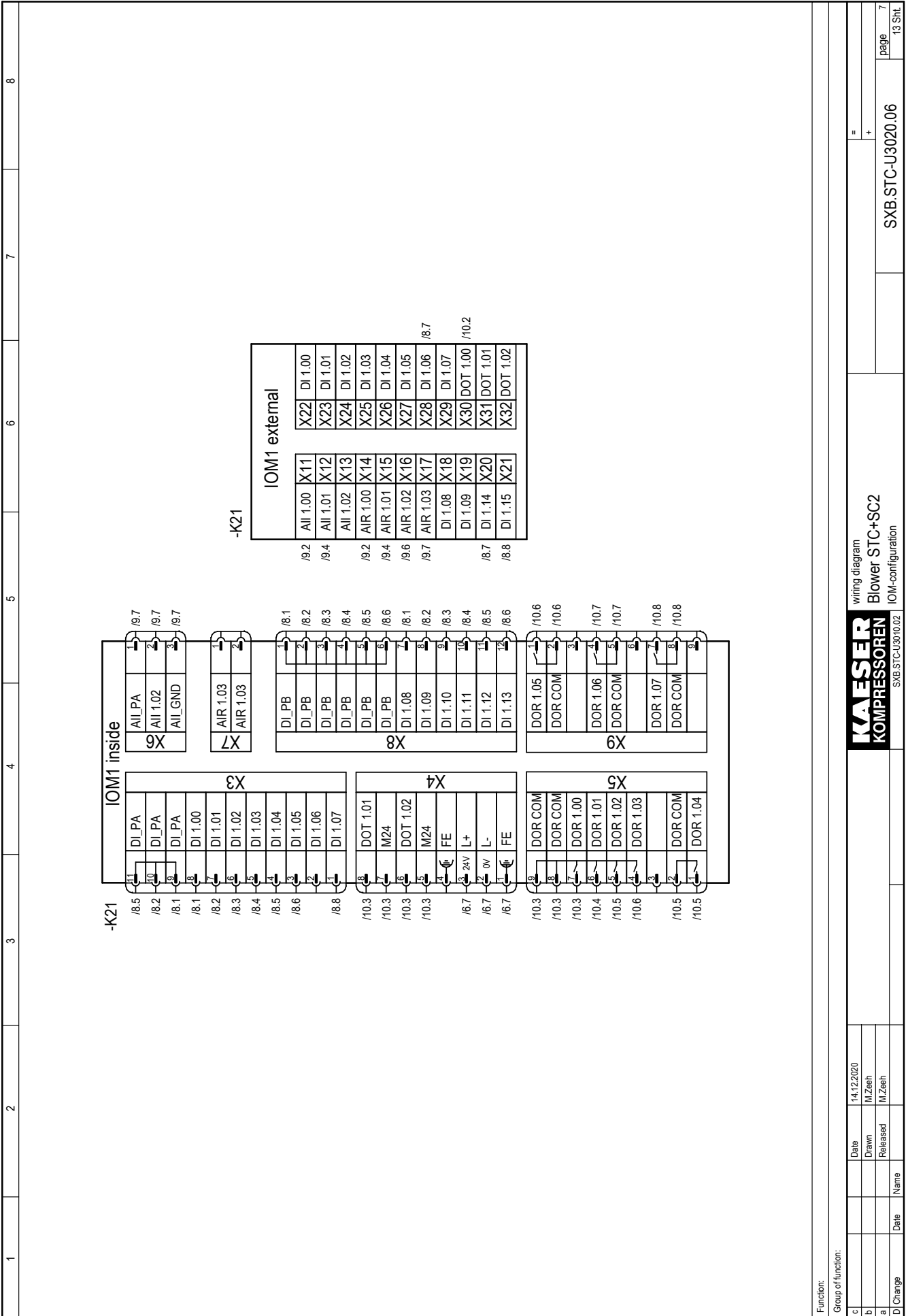

Function:

Group of function:

c	Date	14.12.2020
b	Drawn	M.Zeeh
a	Released	M.Zeeh
D	Change	Date Name

KAESER KOMPRESSOREN SXB.STC-U3010.02

wiring diagram
Blower STC+SC2
IOM-configuration

SXB.STC-U3020.06 = +

page 7
13 Sht

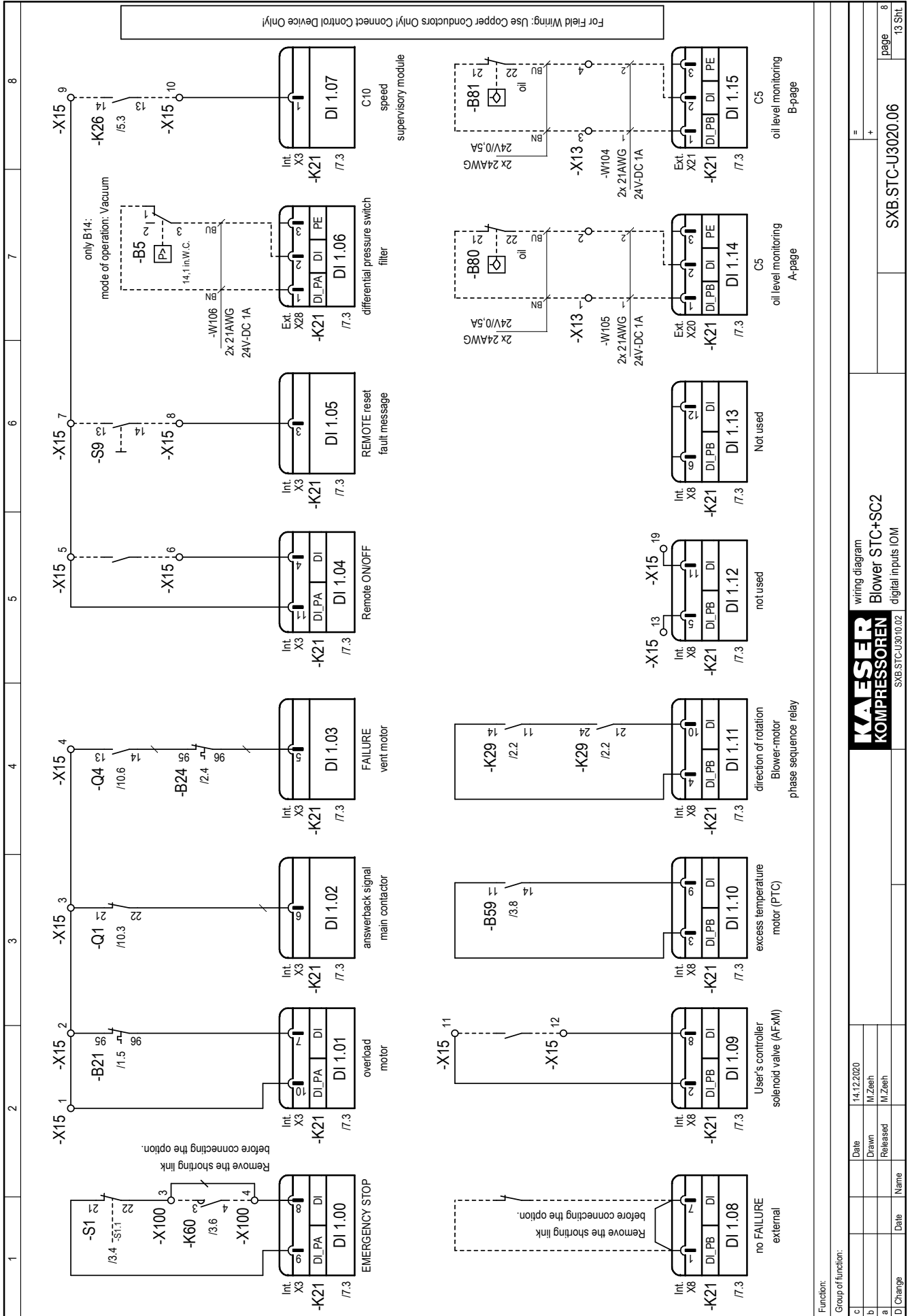

Function:		wiring diagram	
Group of function:		Blower STC+SC2 digital inputs IOM	
c	Date	14.12.2020	page 8
b	Drawn	M.Zeesh	13 Sht
a	Released	M.Zeesh	
d	Change	Date	Name
SX.B.STC-U3020.06		SX.B.STC-U3020.06	

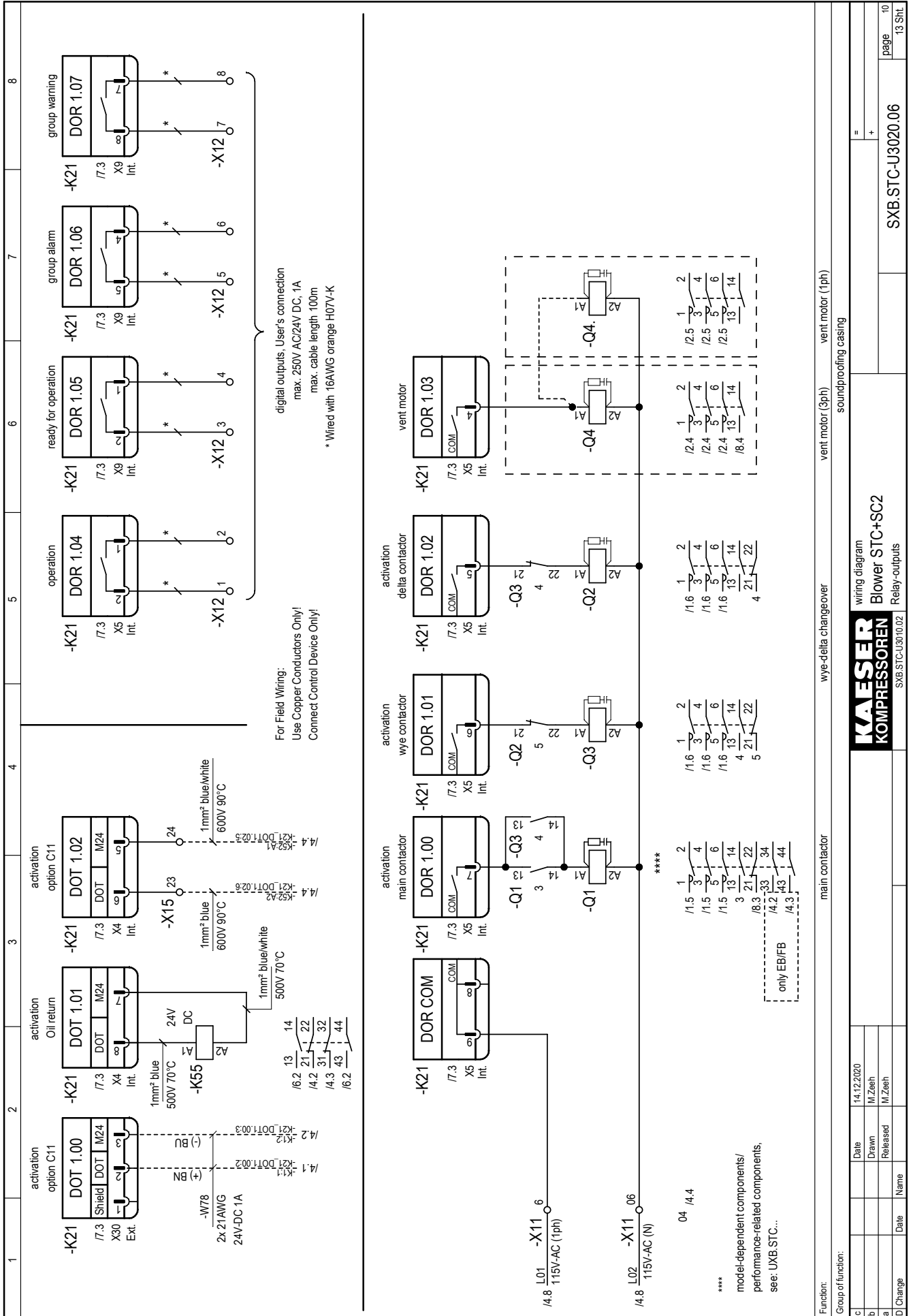

1 2 3 4 5 6 7 8

fig.: 1 Handling control line terminal

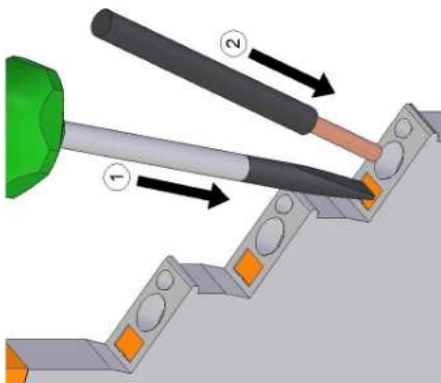

fig.: 2 Handling supply terminals

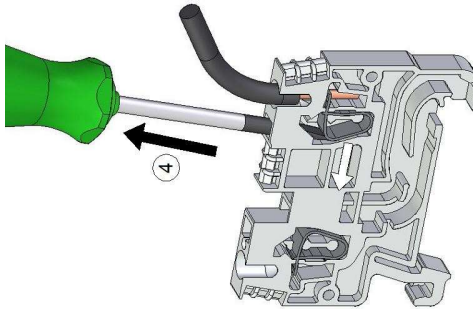
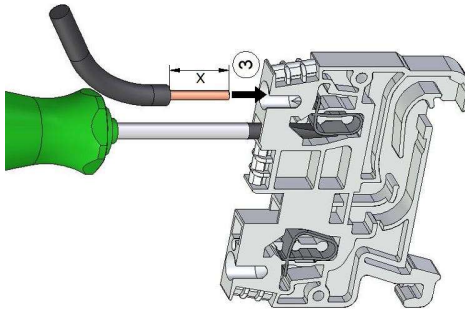
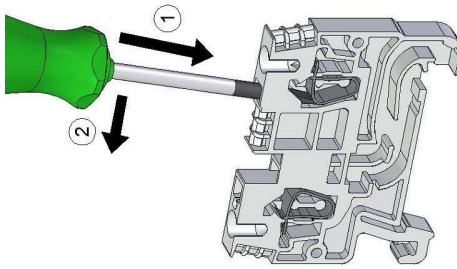
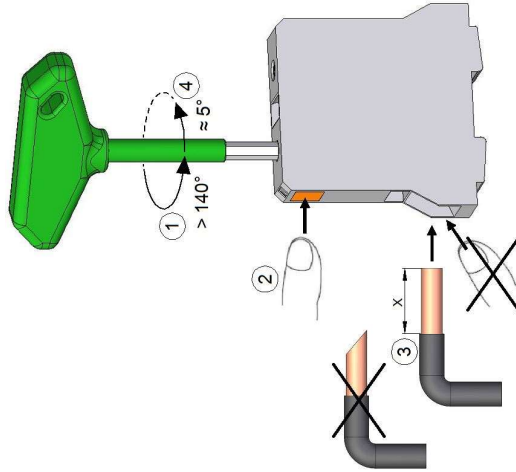

fig.: 3 Handling supply terminals



Function:		wiring diagram		=	
Group of function:		Blower STC+SC2		+	
c	Date	14.12.2020			
b	Drawn	M.Zeesh			
a	Released	M.Zeesh			
D	Change	Date	Name		
			SX.B.STC-U3020.06		
			page 11		
			13 Sht		

1 2 3 4 5 6 7 8

fig.: 1 Feed line connection

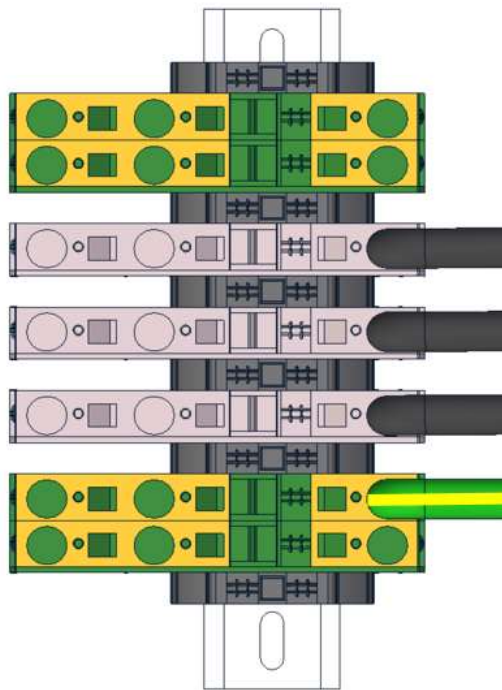
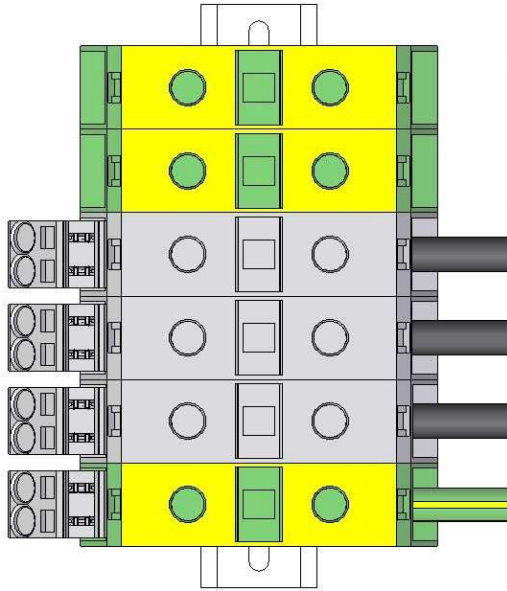
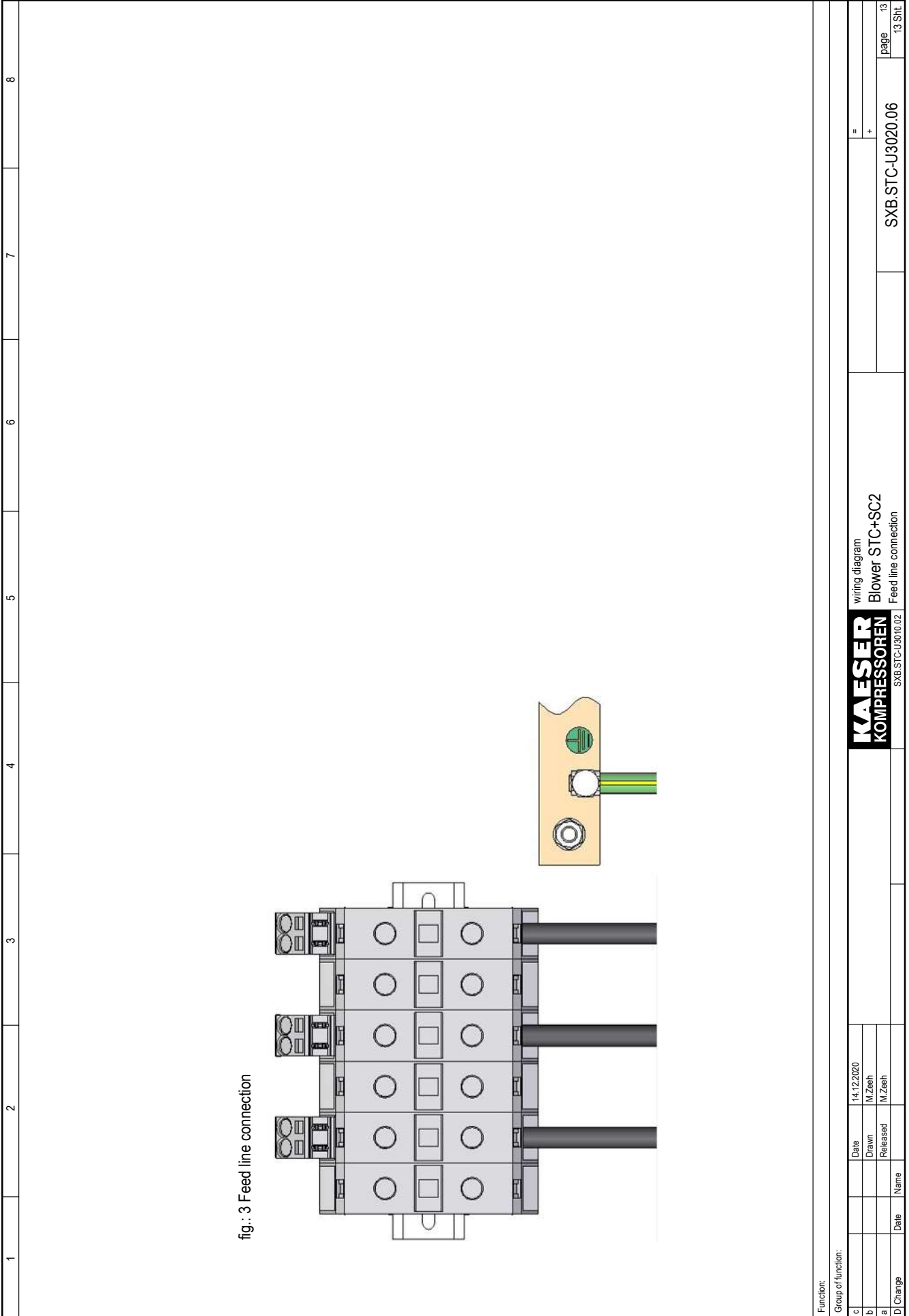

fig.: 2 Feed line connection



Function:			
Group of function:			
c	Date	14.12.2020	
b	Drawn	M.Zeesh	
a	Released	M.Zeesh	
D	Change	Date	Name
		wiring diagram	
		Blower STC+SC2	
		Feed line connection	
		=	
		+	
		SX.B.STC-U3020.06	
		page	
		12	
		13 Sht	



Function:									
Group of function:									
c	Date	14.12.2020	Drawn	M.Zeesh		=			
b	Released		M.Zeesh		+				
a	Date		Name		SX.B.STC-U3020.06		page		13
D	Change				SX.B.STC-U3020.06		13 Sht		

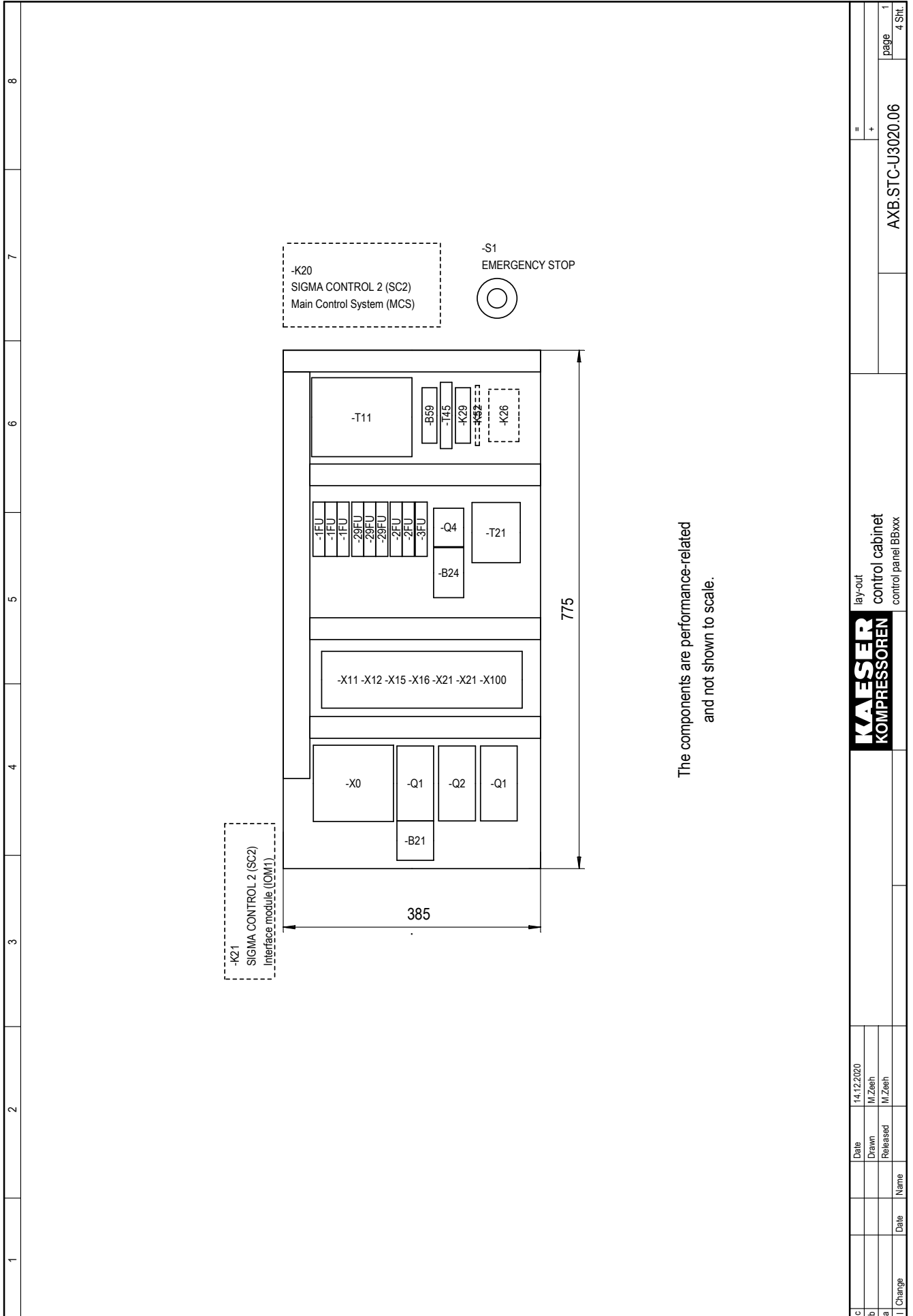

Date		14.12.2020	
Drawn		M.Zeesh	
Released		M.Zeesh	
I Change		Date	Name
		lay-out control cabinet control panel BBxxx	
		AXB.STC-U3020.06	
		= +	
		page 1	
		4 Sht.	

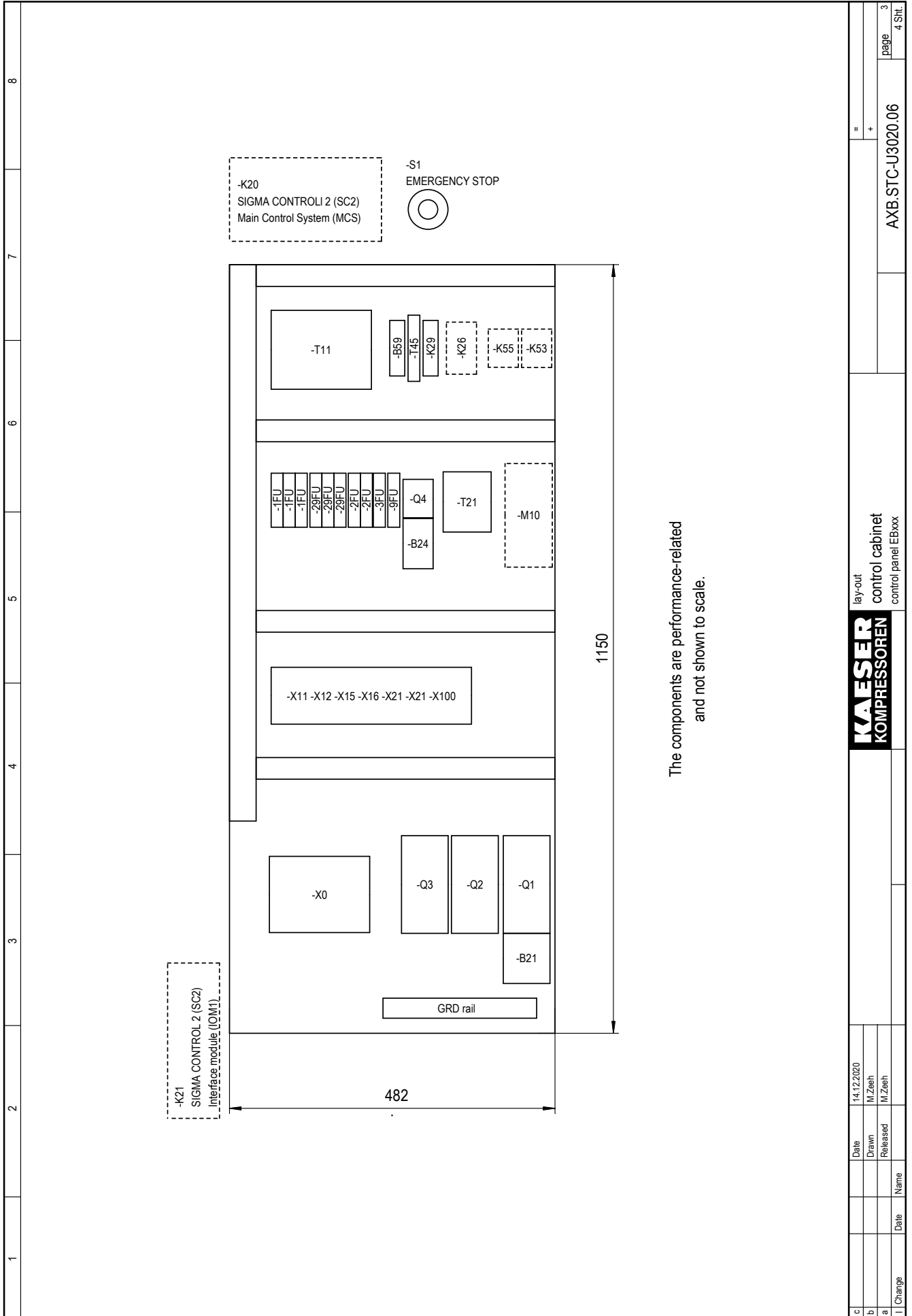

=		+		AXB.STC-U3020.06		page	3
						4 Sht.	
KAESER KOMPRESSOREN				lay-out control cabinet control panel EBxxx			
c	Date	14.12.2020					
b	Drawn	M.Zeeth					
a	Released	M.Zeeth					
I	Change	Date	Name				

13.4.2 Option C34, OMEGA FREQUENCY CONTROL (OFC)

1	2	3	4	5	6	7	8																																
<div style="border: 1px solid black; padding: 10px; margin: 10px auto; width: 80%;"> <p style="font-size: 1.2em; margin: 0;">Wiring Diagram</p> <p style="font-size: 1.2em; margin: 0;">Blower with frequency converter</p> <p style="margin: 0;">Siemens Sinamics G120 PM240-2 + SIGMA CONTROL 2 (SC2)</p> <p style="margin: 0;">460V ±10% 3ph 60Hz 5hp-175hp (4kW-132kW)</p> <p style="margin: 0;">Power supply: WYE system with center point solidly grounded</p> </div>																																							
<p style="margin: 0;">ATTENTION !!! The document gives collective information on power supply voltages and frequencies for all machines. The voltage and frequency and local conditions under which any particular machine may be used are given on the nameplate of the machine and in the accompanying service manual.</p>																																							
<p style="margin: 0;">The drawings remain our exclusive property. They are entrusted only for the agreed purpose. Copies or any other reproductions, including storage, treatment and dissemination by use of electronic systems must not be made for any other than the agreed purpose. Neither originals nor reproductions must be forwarded or otherwise made accessible to third parties.</p>																																							
<p style="margin: 0;">manufacturer: KAESER KOMPRESSOREN SE Postfach 2143 96410 Coburg</p>																																							
<table border="1" style="width: 100%; border-collapse: collapse;"> <tr> <td style="width: 10%; text-align: center;">c</td> <td style="width: 15%;">Datum</td> <td style="width: 15%;">05.02.2018</td> <td style="width: 15%;">USE</td> <td style="width: 10%;"></td> <td style="width: 10%;"></td> <td style="width: 10%;"></td> <td style="width: 10%;"></td> </tr> <tr> <td style="text-align: center;">b</td> <td style="text-align: center;">Bearbeiter</td> <td style="text-align: center;">M.Zeeh</td> <td></td> <td></td> <td></td> <td></td> <td></td> </tr> <tr> <td style="text-align: center;">a</td> <td style="text-align: center;">Geprüft</td> <td style="text-align: center;">M.Zeeh</td> <td></td> <td></td> <td></td> <td></td> <td></td> </tr> <tr> <td style="text-align: center;">A</td> <td style="text-align: center;">Änderung</td> <td style="text-align: center;">Datum</td> <td style="text-align: center;">Name</td> <td style="text-align: center;">Norm</td> <td style="text-align: center;">Ersatz durch:</td> <td style="text-align: center;">Ersatz für:</td> <td></td> </tr> </table>								c	Datum	05.02.2018	USE					b	Bearbeiter	M.Zeeh						a	Geprüft	M.Zeeh						A	Änderung	Datum	Name	Norm	Ersatz durch:	Ersatz für:	
c	Datum	05.02.2018	USE																																				
b	Bearbeiter	M.Zeeh																																					
a	Geprüft	M.Zeeh																																					
A	Änderung	Datum	Name	Norm	Ersatz durch:	Ersatz für:																																	
<table border="1" style="width: 100%; border-collapse: collapse;"> <tr> <td style="width: 10%;"></td> <td style="width: 10%;"></td> <td style="width: 10%;"></td> <td style="width: 10%;"></td> <td style="width: 10%;"></td> <td style="width: 10%;"></td> <td style="width: 10%;"></td> <td style="width: 10%;"></td> </tr> <tr> <td style="text-align: center;">=</td> <td style="text-align: center;">+</td> <td colspan="5"></td> <td style="text-align: center;">page</td> <td style="text-align: center;">1</td> </tr> <tr> <td colspan="6"></td> <td style="text-align: center;">DXB.XFC-U3020.04</td> <td style="text-align: center;">1 Bl.</td> </tr> </table>																=	+						page	1							DXB.XFC-U3020.04	1 Bl.							
=	+						page	1																															
						DXB.XFC-U3020.04	1 Bl.																																

1	2	3	4	5	6	7	8
<p>general instructions</p> <p>ATTENTION !!! Install supplies, grounding and shock protection to local safety regulations. Control circuits are single-end-grounded, if they are floating they may only be used together with insulation monitoring. Do not make or break live plug-in connectors.</p> <p>control cabinet wiring for non-designated conductors with multi-standard stranded conductors primary circuits: control voltage AC 115V: control voltage AC 115V grounded: control voltage DC 24V: control voltage DC 24V grounded: external voltage: ground conductor:</p> <p>black 2,5mm² H07V-K, 14AWG UL-Style 1015, CSA-TEW red 1mm² H05V-K, 18AWG UL-Style 1015, CSA-TEW white 1mm² H05V-K, 18AWG UL-Style 1015, CSA-TEW blue 1mm² H05V-K, 18AWG UL-Style 1015, CSA-TEW blue/white 1mm² H05V-K, 18AWG UL-Style 1015, CSA-TEW orange 1,5mm² H07V-K, 16AWG UL-Style 1015, CSA-TEW green/yellow H07V-K, UL-Style 1015, CSA-TEW</p> <hr style="border-top: 1px dashed black;"/> <p>type model-dependent components</p> <p>B13 = mode of operation overpressure B14 = mode of operation Vacuum C5 = option oil level monitoring (-B80/-B81) (standard by Screw blowers) C10 = option Speed monitoring (-K26+sensor -B90) C11 = option Unloaded start valve C34 = OMEGA FREQUENCY CONTROL C38 = SIGMA FREQUENCY CONTROL C39 = option oil temperature monitoring (-B55) (standard by Screw blowers) xxx = Gear housing ventilation+Oil return (only EBS/FBS)</p>							
<p>c Datum 05.02.2018</p> <p>b Bearbeiter M.Zeeh</p> <p>a Geprüft M.Zeeh</p> <p>C:Änderung Datum Name Norm</p>		<p>General instructions Blower xFC+SC2 instructions + option</p>		<p>KAESER KOMPRESSOREN [Ursprung]</p>		<p>= + UXB.XFC-U3020.04</p>	
						page 1	11 Bl.

	1	2	3	4	5	6	7	8
-B1/-B4	pressure transducer (4...20mA)							
-B5	differential pressure switch filter clogging							
-B24	overload Relay vent motor							
-B40/-B43	temperature probe Blower (PT100)							
-B55	temperature probe PT100 (option)							
-B60	thermistor, compressor motor							
-B70	temperature probe soundproofing casing							
-B80/-B81	oil level switch							
-B90	speed sensor							
-0FU	fuse motor Blower							
-1FU	fuse control voltage tapping							
-2FU	primary control fuse control transformer							
-3FU	secondary control fuse control transformer							
-8FU	fuse controller ventilator							
-10FU	fuse 24V-AC							
-29FU	fuse phase sequence relay							
-F86	Surge protective device (Canada only)							
-K1	solenoid valve							
-K10	solenoid valve Oil return							
-K20	SIGMA CONTROL 2 (SC2) (MCS)							
-K21	SIGMA CONTROL 2 (SC2) (IOM-Modul)							
-K26	speed supervisory module							
-K29	phase sequence relay							
-K50	coupling relay controller ventilator							
-K51	coupling relay ventilator							
-K52	coupling relay solenoid valve							
-K55	coupling relay Oil return							
-K60	EMERGENCY STOP (external/customer)							
-M1	motor Blower							
-M4	ventilator soundproofing casing							
-M8	controller ventilator (1)							
-M9	controller ventilator (2)							
-M10	vacuum pump Gear housing ventilation							
-Q4	contactor ventilator soundproofing casing							
-R1	line commutation reactor							
-R3.1	ferrit bead power supply							
-R3.2	ferrit bead Motor cable							
-R11	interference suppression filter							
-S1	EMERGENCY STOP pushbutton							
-S9	REMOTE reset fault message							
-T1	frequency converter							
-T11	control transformer 230V-AC							
-T12	control voltage supply 24V-DC							
-T45	isolating amplifier							
-X0	terminal strip, power supply							
-X11	terminal strip, control							
-X12	SC2-IOM digital outputs							
-X15	SC2-IOM digital inputs							
-X16	frequency converter analog signals							
-X21	control voltage 24V-DC							
-X22	frequency converter 24V-DC							
-X100	EMERGENCY STOP (external/customer)							
-K20	Main Control System SC2 MCS							
-X1	Ethernet							
-X2	IO-BUS							
-X3	RS485-FC (USS-Bus)							
-X4	communication module							
-X5	SD card slot							
-X6	ground connection							
-K21	IO-Modul SC2 IOM-1							
-X1	IO-Bus input							
-X2	IO-Bus output							
-X3	digital inputs							
-X4	power supply unit							
-X5,-X9	and Transistor outputs							
-X6	Relay outputs							
-X7	analog input 0-20mA							
-X8	analog input PT100							
	digital inputs							
	external							
-X11...-X13	analog inputs 0-20mA							
-X14...-X17	analog inputs PT100							
-X18...-X29	digital inputs							
-X30...-X32	digital outputs							



component legend
Blower xFC+SC2
component legend

Common parts		5 - 175 hp / 4 - 132 kW		= +		UXB.XFC-U3020.04		page 3		11 Bl.	
model											
machine power supply	460 V ±10 %, 60 Hz										
pressure transducer	-B1 Huba Control	894786.0 0.-1200mbar									
pressure transducer	-B4 Huba Control	894787.0 0.1200mbar									
differential pressure switch	-B5 Dungs	893307.00010 setting: 14,1 in.W.C.									
temperature probe	-B40/-B43 WIKA	895251.10010 (BB/CB/DB) 895251.10040 (EB-C/FB) 895603.00040 (EB-S) Pt100									
temperature probe	-B55	895251.10100 895603.00100 (EB-S) Pt100									
temperature probe	-B70 Wieland	7.7631.0-P21 PT100									
fuse	-1FU Gould	(3x) - 7.3161.00190 ATQR 8 A - 600 V - class CC									
fuse	-2FU Gould	(2x) - 7.3317.1 ATQR 3 A - 600 V - class CC									
fuse	-3FU Gould	(1x) - 7.3161.00160 ATQR 5 A - 600 V - class CC									
fuse	-8FU Gould	(1x) - 7.3304.00010 ATDR 2 A - 600 V - class CC									
fuse	-10FU	895637.0 5x20 0,315 A-T 250 VAC									
fuse	-29FU Gould	(3x) - 7.3161.00360 ATDR 1 A - 600 V - class CC									
fuse socket	-1FU/-29FU -2FU -3FU/-8FU Wöhner	3-pole (2x) - 7.3320.00060 2-pole (1x) - 7.3320.00070 1-pole (2x) - 7.3320.00050 class CC - Ambus Easy Switch									
solenoid valve	-K10 bükert	895601.0 24V-DC 8W									
Blower control	-K20 Prodrive	7.7601.0 SC2MCS									
Blower control	-K21 Prodrive	7.7602.1 SC2IOM-1									
phase sequence relay	-K29 Siemens	7.7830.00600 3UG4615									
coupling relay	-K50/-K51 Wieland	7.3149.00660 24DC-1W-250V6A									
coupling relay	-K55 Siemens	7.8740.04210 3RH2122-1JB40 DC 17-30 V AC-15: 230 V/10 A									
vacuum pump	-M10 Schwarzer	895612.00100 24V-AC 60 Hz, 4W									
Fortsetzung: nächstes Blatt											
c	Datum	05.02.2018									
b	Bearbeiter	M.Zeeh									
a	Geprüft	M.Zeeh									
C-Änderung	Norm										
	Name										
	Datum										
	Ersatz durch:										
	Ersatz für:										
	electrical component parts list										
	Blower xFC+SC2										
	Common parts										
	KAESER KOMPRESSOREN										
	Ursprung:										

model		Common parts 5 - 175 hp / 4 - 132 kW		page 4 11 Bl.	
machine power supply		460 V ±10 %, 60 Hz		UXB.XFC-U3020.04	
contactor	-Q4 Siemens	7.8740.00310 3RT2016-1AK61	= +		
interference suppressor	.	7.8740.05130 Siemens 3RT2916-1CC00			
control transformer	-T11 Block	7.2238.10090 USTE630 - 630 VA 208-600 V/2x 115 V+ 24 V			
power supply	-T21 Prodrive	7.7605P0 PSDC24/2.5 100-240 V-AC/24 V-DC 2,5 A			
isolating amplifier	-T45 Phoenix	7.2892.00040 MCR-C-III-00-DC			
control line terminal	-X. 11/12/15/16/21/22/100 Handling	895635.0 Wieland WTP fig. 1, Sht. 11			
				electrical component parts list Blower xFC+SC2 Common parts	
				KAESER KOMPRESSOREN Ursprung:	
				Ersatz für:	
				Ersatz durch:	
c	Datum	05.02.2018			
b	Bearbeiter	M.Zeeh			
a	Geprüft	M.Zeeh			
C-Änderung	Name				
	Datum				

model	performance-related components					page 6 11 Bl.
	5 hp BB (4 kW)	7,5 hp BB+ CB+DB (5,5 kW)	10 hp BB+ CB+DB (7,5 kW)	15 hp BB+ CB+DB 11 kW)	20 hp BB+ CB+DB (15 kW)	
machine power supply	460 V ±10 %, 60 Hz	460 V ±10 %, 60 Hz	460 V ±10 %, 60 Hz	460 V ±10 %, 60 Hz	460 V ±10 %, 60 Hz	= + UXB.XFC-U3020.04
overload relay soundproofing casing	-B24 7.8741.00030 3RB3016-1PB0 1,00-4,00 A / S00 setting: 1,43 A NEC 430.32(C) incremental setting: 1,61 A Siemens	7.8741.00030 3RB3016-1PB0 1,00-4,00 A / S00 setting: 1,43 A NEC 430.32(C) incremental setting: 1,61 A	7.8741.00030 3RB3016-1PB0 1,00-4,00 A / S00 setting: 1,43 A NEC 430.32(C) incremental setting: 1,61 A	7.8741.00030 3RB3016-1PB0 1,00-4,00 A / S00 setting: 1,43 A NEC 430.32(C) incremental setting: 1,61 A	7.8741.00030 3RB3016-1PB0 1,00-4,00 A / S00 setting: 1,43 A NEC 430.32(C) incremental setting: 1,61 A	
Surge protective device	-F86 Dehn 7.8669.00020 DG MU 3PY 480 3W+ G	7.8669.00020 DG MU 3PY 480 3W+ G	7.8669.00020 DG MU 3PY 480 3W+ G	7.8669.00020 DG MU 3PY 480 3W+ G	7.8669.00020 DG MU 3PY 480 3W+ G	electrical component parts list BB+CB+DB performance-related components
Blower motor	-M1 Siemens 894989.0 460 V-D/60 Hz 7 A, 3600U	894990.0 460 V-D/60 Hz 10,1 A, 3600U	894991.0 460 V-D/60 Hz 13,2 A, 3600U	894992.0 460 V-D/60 Hz 20,2 A, 3600U	895049.0 460 V-D/60 Hz 27,6 A, 3600U	
vent motor soundproofing casing	-M4 ebm 895260.00010 W2D250 115 V/60 Hz (1Ph/N/GRD) 175W 1,55 A	895260.00010 W2D250 115 V/60 Hz (1Ph/N/GRD) 175W 1,55 A	895260.00010 W2D250 115 V/60 Hz (1Ph/N/GRD) 175W 1,55 A	895260.00010 W2D250 115 V/60 Hz (1Ph/N/GRD) 175W 1,55 A	895260.00010 W2D250 115 V/60 Hz (1Ph/N/GRD) 175W 1,55 A	
vent motor control cabinet	-M8 / (-M9) Ruebsamen 7.2751.00490 LV410 (1Ph/N/GRD) 115 V/60 Hz, 40W 0,5 A	7.2751.00490 LV410 (1Ph/N/GRD) 115 V/60 Hz, 40W 0,5 A	7.2751.00490 LV410 (1Ph/N/GRD) 115 V/60 Hz, 40W 0,5 A	7.2751.00490 LV410 (1Ph/N/GRD) 115 V/60 Hz, 40W 0,5 A	7.2751.00490 LV410 (1Ph/N/GRD) 115 V/60 Hz, 40W 0,5 A	
line commutation reactor	-R1 Siemens 7.7831.00310 6SL3203-0CE21-8AA0	7.7831.00310 6SL3203-0CE21-8AA0	7.7831.00310 6SL3203-0CE21-8AA0	7.7831.00320 6SL3203-0CE23-8AA0	7.7831.00320 6SL3203-0CE23-8AA0	
ferrit bead	-R3.1 -R3.2 Magnetec 7.8538.0 (M112) 1x 7.8538.0 (M112)	7.8538.0 (M112) 1x 7.8538.0 (M112)	7.8538.0 (M112) 1x 7.8538.0 (M112)	7.8538.0 (M112) 1x 7.8538.0 (M112)	7.8538.0 (M112) 1x 7.8538.0 (M112)	
interference suppression filter	-R11 Siemens integrated ---	integrated ---	integrated ---	7.8832.10030 Schaffner FS33891-50-07	7.8832.10030 Schaffner FS33891-50-07	
frequency converter control unit instrument panel	-T1 Siemens 7.8833.01070 6SL3210-1PE21-1AL0 7.7830.00710 6SL3244-0BB12-1BAx 7.7830.00100 6SL3255-0AA00-4CA1	7.8833.01080 6SL3210-1PE21-4AL0 7.7830.00710 6SL3244-0BB12-1BAx 7.7830.00100 6SL3255-0AA00-4CA1	7.8833.01090 6SL3210-1PE21-8AL0 7.7830.00710 6SL3244-0BB12-1BAx 7.7830.00100 6SL3255-0AA00-4CA1	7.8833.00100 6SL3210-1PE22-7UL0 7.7830.00710 6SL3244-0BB12-1BAx 7.7830.00100 6SL3255-0AA00-4CA1	7.8833.00110 6SL3210-1PE23-3UL0 7.7830.00710 6SL3244-0BB12-1BAx 7.7830.00100 6SL3255-0AA00-4CA1	
motor cable	-W211 4x10 AWG / 4G6 mm ² 600 V - 80°C - EMV	4x10 AWG / 4G6 mm ² 600 V - 80°C - EMV	4x10 AWG / 4G6 mm ² 600 V - 80°C - EMV	4x8 AWG / 4G10 mm ² 600 V - 80°C - EMV	4x8 AWG / 4G10 mm ² 600 V - 80°C - EMV	
connection	-W280.1/2 -W281 -W282 10 AWG / 6 mm ² 10 AWG / 6 mm ² 10 AWG / 6 mm ² 600 V - 90°C	10 AWG / 6 mm ² 10 AWG / 6 mm ² 10 AWG / 6 mm ² 600 V - 90°C	10 AWG / 6 mm ² 10 AWG / 6 mm ² 10 AWG / 6 mm ² 600 V - 90°C	8 AWG / 10 mm ² 8 AWG / 10 mm ² 8 AWG / 10 mm ² 600 V - 90°C	8 AWG / 10 mm ² 8 AWG / 10 mm ² 8 AWG / 10 mm ² 600 V - 90°C	
supply terminals supply	-X0: U1/N1/W1/GRD Handling Stripped length X connection 894864.00010 Wieland 14-4 AWG/2,5-16 mm ² fig. 2, Sht. 12 16 mm fig. 1, Sht. 13	894864.00010 Wieland 14-4 AWG/2,5-16 mm ² fig. 2, Sht. 12 16 mm fig. 1, Sht. 13	894864.00010 Wieland 14-4 AWG/2,5-16 mm ² fig. 2, Sht. 12 16 mm fig. 1, Sht. 13	894864.00010 Wieland 14-4 AWG/2,5-16 mm ² fig. 2, Sht. 12 16 mm fig. 1, Sht. 13	894864.00010 Wieland 14-4 AWG/2,5-16 mm ² fig. 2, Sht. 12 16 mm fig. 1, Sht. 13	

c	Datum	05.02.2018
b	Bearbeiter	M.Zeeh
a	Geprüft	IM.Zeeh
	Norm	
	Name	
	Datum	
	C-Änderung	

model	performance-related components					page 7 11 Bl.																	
	25 hp CB+ DB 18,5W)	30 hp CB+ DB (22 kW)	40 hp CB+ DB (30 kW)	50 hp DB (37 kW)	60 hp DB (45 kW)																		
machine power supply	460 V ±10 %, 60 Hz	460 V ±10 %, 60 Hz	460 V ±10 %, 60 Hz	460 V ±10 %, 60 Hz	460 V ±10 %, 60 Hz	= + UXB.XFC-U3020.04																	
overload relay soundproofing casing	-B24 7.8741.00030 3RB3016-1PB0 1,00-4,00 A / S00 setting: 1,43 A NEC 430.32(C) incremental setting: 1,61 A Siemens	7.8741.00030 3RB3016-1PB0 1,00-4,00 A / S00 setting: 1,43 A NEC 430.32(C) incremental setting: 1,61 A	7.8741.00030 3RB3016-1PB0 1,00-4,00 A / S00 setting: 1,43 A NEC 430.32(C) incremental setting: 1,61 A	7.8741.00030 3RB3016-1PB0 1,00-4,00 A / S00 setting: 1,43 A NEC 430.32(C) incremental setting: 1,61 A	7.8741.00030 3RB3016-1PB0 1,00-4,00 A / S00 setting: 1,43 A NEC 430.32(C) incremental setting: 1,61 A																		
Surge protective device	-F86 Dehn 7.8669.00020 DG MU 3PY 480 3W+ G	7.8669.00020 DG MU 3PY 480 3W+ G	7.8669.00020 DG MU 3PY 480 3W+ G	7.8669.00020 DG MU 3PY 480 3W+ G	7.8669.00020 DG MU 3PY 480 3W+ G	electrical component parts list CB+DB performance-related components																	
Blower motor	-M1 Siemens 894994.0 460 V-D/60 Hz 32,2 A, 3600U	894995.0 460 V-D/60 Hz 38,5 A, 3600U	894996.1 (CB) 894997.1 (DB) 460 V-D/60 Hz 52 A, 3600U	894978.1 460 V-D/60 Hz 63,3 A, 3600U	894979.1 460 V-D/60 Hz 78 A, 3600U																		
vent motor soundproofing casing	-M4 ebm 895260.00010 W2D250 115 V/60 Hz (1Ph/N/GRD) 175W 1,55 A	895260.00010 W2D250 115 V/60 Hz (1Ph/N/GRD) 175W 1,55 A	895260.00010 W2D250 115 V/60 Hz (1Ph/N/GRD) 175W 1,55 A	895260.00010 W2D250 115 V/60 Hz (1Ph/N/GRD) 175W 1,55 A	895260.00010 W2D250 115 V/60 Hz (1Ph/N/GRD) 175W 1,55 A																		
vent motor control cabinet	-M8 / (-M9) Ruebsamen 7.2751.00490 LV410 (1Ph/N/GRD) 115 V/60 Hz, 40W 0,5 A	7.2751.00490 LV410 (1Ph/N/GRD) 115 V/60 Hz, 40W 0,5 A	7.2751.00490 LV410 (1Ph/N/GRD) 115 V/60 Hz, 40W 0,5 A	7.2751.00490 LV410 (1Ph/N/GRD) 115 V/60 Hz, 40W 0,5 A	7.2751.00490 LV410 (1Ph/N/GRD) 115 V/60 Hz, 40W 0,5 A																		
line commutation reactor	-R1 Siemens integrated ---	integrated ---	integrated ---	integrated ---	integrated ---																		
ferrit bead	-R3.1 -R3.2 Magnetec 7.8538.0 (M112) 1x 7.8538.0 (M112)	7.8538.0 (M112) 1x 7.8538.0 (M112)	7.8538.0 (M112) 1x 7.8538.0 (M112)	7.8538.0 (M112) 2x 7.8538.0 (M112)	7.8538.0 (M112) 2x 7.8538.0 (M112)																		
interference suppression filter	-R11 Siemens integrated ---	integrated ---	integrated ---	integrated ---	integrated ---																		
frequency converter control unit instrument panel	-T1 Siemens 7.8833.01120 6SL3210-1PE23-8AL0 7.7830.00710 6SL3244-0BB12-1BAx 7.7830.00100 6SL3255-0AA00-4CA1	7.8833.01130 6SL3210-1PE24-5AL0 7.7830.00710 6SL3244-0BB12-1BAx 7.7830.00100 6SL3255-0AA00-4CA1	7.8833.01140 6SL3210-1PE26-0AL0 7.7830.00710 6SL3244-0BB12-1BAx 7.7830.00100 6SL3255-0AA00-4CA1	7.8833.01150 6SL3210-1PE27-5AL0 7.7830.00710 6SL3244-0BB12-1BAx 7.7830.00100 6SL3255-0AA00-4CA1	7.8833.01160 6SL3210-1PE28-8AL0 7.7830.00710 6SL3244-0BB12-1BAx 7.7830.00100 6SL3255-0AA00-4CA1																		
motor cable	-W211 4x6 AWG / 4G16 mm ² 600 V - 80°C - EMV	4x6 AWG / 4G16 mm ² 600 V - 80°C - EMV	2x 4x8 AWG/4G10 mm ² (CB) 4x4 AWG / 4G25 mm ² (DB) 600 V - 80°C - EMV	4x2 AWG / 4G35 mm ² 600 V - 80°C - EMV	3x 1 AWG / 50 mm ² 4 AWG / 25 mm ² (GRD) 600 V - 90°C																		
connection	-W280.1/2 -W281 -W282 8 AWG / 10 mm ² 8 AWG / 10 mm ² 8 AWG / 10 mm ² 600 V - 90°C	8 AWG / 10 mm ² 8 AWG / 10 mm ² 8 AWG / 10 mm ² 600 V - 90°C	4 AWG / 25 mm ² 4 AWG / 25 mm ² 4 AWG / 25 mm ² 600 V - 90°C	4 AWG / 25 mm ² 4 AWG / 25 mm ² 4 AWG / 25 mm ² 600 V - 90°C	2 AWG / 35 mm ² 4 AWG / 25 mm ² 2 AWG / 35 mm ² 600 V - 90°C																		
supply terminals supply	-X0: U1/N1/W1/GRD Handling Stripped length X connection 894864.00010 Wieland 14-4 AWG/2,5-16 mm ² fig. 2, Sht. 12 16 mm fig. 1, Sht. 13	894864.00010 Wieland 14-4 AWG/2,5-16 mm ² fig. 2, Sht. 12 16 mm fig. 1, Sht. 13	3x 895314.0 3x 895314.00010 4x 895314.00040 Wago 8-1 AWG/10-50 mm ² fig. 3, Sht. 12 30 mm fig. 2, Sht. 13	3x 895314.0 3x 895314.00010 4x 895314.00040 Wago 8-1 AWG/10-50 mm ² fig. 3, Sht. 12 30 mm fig. 2, Sht. 13	3x 895314.0 3x 895314.00010 4x 895314.00040 Wago 8-1 AWG/10-50 mm ² fig. 3, Sht. 12 30 mm fig. 2, Sht. 13																		
<table border="1"> <tr> <td>c</td> <td>Datum</td> <td>05.02.2018</td> </tr> <tr> <td>b</td> <td>Bearbeiter</td> <td>M.Zeeh</td> </tr> <tr> <td>a</td> <td>Geprüft</td> <td>Il/Zeeh</td> </tr> <tr> <td>C-Änderung</td> <td>Norm</td> <td></td> </tr> <tr> <td></td> <td>Name</td> <td></td> </tr> <tr> <td></td> <td>Datum</td> <td></td> </tr> </table>						c	Datum	05.02.2018	b	Bearbeiter	M.Zeeh	a	Geprüft	Il/Zeeh	C-Änderung	Norm			Name			Datum	
c	Datum	05.02.2018																					
b	Bearbeiter	M.Zeeh																					
a	Geprüft	Il/Zeeh																					
C-Änderung	Norm																						
	Name																						
	Datum																						

model	performance-related components				page 8	11 Bl.
	25 hp EB 18,5W)	30 hp EB (22 kW)	40 hp EB+ FB-C (30 kW)	40 hp FB-S (30 kW)		
machine power supply	460 V ±10 %, 60 Hz	460 V ±10 %, 60 Hz	460 V ±10 %, 60 Hz	460 V ±10 %, 60 Hz	= +	UXB.XFC-U3020.04
overload relay soundproofing casing	-B24 7.8741.00020 3RB3016-1NB0 0,32-1,25 A / S00 setting: 0,57 A Siemens NEC 430.32(C) incremental setting: 0,64 A	7.8741.00020 3RB3016-1NB0 0,32-1,25 A / S00 setting: 0,57 A NEC 430.32(C) incremental setting: 0,64 A	7.8741.00020 3RB3016-1NB0 0,32-1,25 A / S00 setting: 0,57 A NEC 430.32(C) incremental setting: 0,64 A	7.8741.00020 3RB3016-1NB0 0,32-1,25 A / S00 setting: 0,57 A NEC 430.32(C) incremental setting: 0,64 A		
Surge protective device	-F86 Dehn 7.8669.00020 DG MU 3PY 480 3W+ G	7.8669.00020 DG MU 3PY 480 3W+ G	7.8669.00020 DG MU 3PY 480 3W+ G	7.8669.00020 DG MU 3PY 480 3W+ G		
Blower motor	-M1 894994.0 Siemens 460 V-D/60 Hz 32,2 A, 3600U	894995.0 460 V-D/60 Hz 38,5 A, 3600U	894997.1 460 V-D/60 Hz 52 A, 3600U	894997.1 460 V-D/60 Hz 52 A, 3600U		
vent motor soundproofing casing	-M4 895040.00040 Sodeca/ebm HC-31-2T / H-I-E 460 V-Y/60 Hz (3PH/GRD) 210W 0,62 A	895040.00040 HC-31-2T / H-I-E 460 V-Y/60 Hz (3PH/GRD) 210W 0,62 A	895040.00040 HC-31-2T / H-I-E 460 V-Y/60 Hz (3PH/GRD) 210W 0,62 A	895426.0 W4D420 (ebm) 460 V-Y/60 Hz (3PH/GRD) 265W 0,62 A		
vent motor control cabinet	-M8/-M9 7.2751.00360 Ruebsamen LV600 (1Ph/N/GRD) 115 V/60 Hz, 80W 0,7 A	7.2751.00360 LV600 (1Ph/N/GRD) 115 V/60 Hz, 80W 0,7 A	7.2751.00360 LV600 (1Ph/N/GRD) 115 V/60 Hz, 80W 0,7 A	7.2751.00360 LV600 (1Ph/N/GRD) 115 V/60 Hz, 80W 0,7 A		
line commutation reactor	-R1 Siemens integrated ---	integrated ---	integrated ---	integrated ---		
ferrit bead	-R3.1 -R3.2 Magnetec 7.8538.0 (M112) 1x 7.8538.0 (M112)	7.8538.0 (M112) 1x 7.8538.0 (M112)	7.8538.0 (M112) 1x 7.8538.0 (M112)	7.8538.0 (M112) 1x 7.8538.0 (M112)		
interference suppression filter	-R11 Siemens integrated ---	integrated ---	integrated ---	integrated ---		
frequency converter control unit instrument panel	-T1 7.8833.01120 6SL3210-1PE23-8AL0 7.7830.00710 6SL3244-0BB12-1BAx 7.7830.00100 Siemens 6SL3255-0AA00-4CA1	7.8833.01130 6SL3210-1PE24-5AL0 7.7830.00710 6SL3244-0BB12-1BAx 7.7830.00100 6SL3255-0AA00-4CA1	7.8833.01140 6SL3210-1PE26-0AL0 7.7830.00710 6SL3244-0BB12-1BAx 7.7830.00100 6SL3255-0AA00-4CA1	7.8833.01140 6SL3210-1PE26-0AL0 7.7830.00710 6SL3244-0BB12-1BAx 7.7830.00100 6SL3255-0AA00-4CA1		
motor cable	-W211 4x6 AWG / 4G16 mm ² 600 V - 80°C - EMV	4x6 AWG / 4G16 mm ² 600 V - 80°C - EMV	4x 4 AWG / 25 mm ² 600 V - 90°C	4x 4 AWG / 25 mm ² 600 V - 90°C		
connection	-W280.1/2 -W281 -W282 8 AWG / 10 mm ² 8 AWG / 10 mm ² 8 AWG / 10 mm ² 600 V - 90°C	6 AWG / 16 mm ² 6 AWG / 16 mm ² 6 AWG / 16 mm ² 600 V - 90°C	4 AWG / 25 mm ² 4 AWG / 25 mm ² 4 AWG / 25 mm ² 600 V - 90°C	4 AWG / 25 mm ² 4 AWG / 25 mm ² 4 AWG / 25 mm ² 600 V - 90°C		
supply terminals supply	-X0: U1/V1/W1/GRD 894864.00010 Wieland 14-4 AWG/2,5-16 mm ² fig. 2, Sht. 12 16 mm fig. 1, Sht. 13 Handling Stripped length X connection	894864.00010 Wieland 14-4 AWG/2,5-16 mm ² fig. 2, Sht. 12 16 mm fig. 1, Sht. 13	3x 895314.0 3x 895314.00010 4x 895314.00040 Wago 8-1 AWG/10-50 mm ² fig. 3, Sht. 12 30 mm fig. 2, Sht. 13	3x 895314.0 3x 895314.00010 4x 895314.00040 Wago 8-1 AWG/10-50 mm ² fig. 3, Sht. 12 30 mm fig. 2, Sht. 13		

electrical component parts list
EB+FB
performance-related components

KAESER
KOMPRESSOREN
Ursprung:

Ersatz für:

Ersatz durch:

c	Datum	05.02.2018
b	Bearbeiter	M.Zeeh
a	Geprüft	IM.Zeeh
C	Änderung	
	Name	
	Datum	

model	performance-related components				page 9 11 Bl.
	50 hp EB+ FB-C (37 kW)	50 hp FB-S (37 kW)	60 hp EB+ FB-C (45 kW)	60 hp FB-S (45 kW)	
machine power supply	460 V ±10 %, 60 Hz	460 V ±10 %, 60 Hz	460 V ±10 %, 60 Hz	460 V ±10 %, 60 Hz	= + UXB.XFC-U3020.04
overload relay soundproofing casing Siemens	-B24 7.8741.00020 3RB3016-1NB0 0,32-1,25 A / S00 setting: 0,57 A NEC 430.32(C) incremental setting: 0,64 A	7.8741.00020 3RB3016-1NB0 0,32-1,25 A / S00 setting: 0,57 A NEC 430.32(C) incremental setting: 0,64 A	7.8741.00020 3RB3016-1NB0 0,32-1,25 A / S00 setting: 0,57 A NEC 430.32(C) incremental setting: 0,64 A	7.8741.00020 3RB3016-1NB0 0,32-1,25 A / S00 setting: 0,57 A NEC 430.32(C) incremental setting: 0,64 A	
Surge protective device Dehn	-F86 7.8669.00020 DG MU 3PY 480 3W+ G	7.8669.00020 DG MU 3PY 480 3W+ G	7.8669.00020 DG MU 3PY 480 3W+ G	7.8669.00020 DG MU 3PY 480 3W+ G	electrical component parts list EB+FB performance-related components
Blower motor Siemens	-M1 894978.1 460 V-D/60 Hz 63,3 A, 3600U	894978.1 460 V-D/60 Hz 63,3 A, 3600U	894979.1 460 V-D/60 Hz 78 A, 3600U	894979.1 460 V-D/60 Hz 78 A, 3600U	
vent motor soundproofing casing Sodeca/ebm	-M4 895040.00040 HC-31-2T / H-I-E 460 V-Y/60 Hz (3PH/GRD) 210W 0,62 A	895426.0 W4D420 (ebm) 460 V-Y/60 Hz (3PH/GRD) 265W 0,62 A	895040.00040 HC-31-2T / H-I-E 460 V-Y/60 Hz (3PH/GRD) 210W 0,62 A	895426.0 W4D420 (ebm) 460 V-Y/60 Hz (3PH/GRD) 265W 0,62 A	KAESER KOMPRESSOREN Ursprung
vent motor control cabinet Ruebsamen	-M8/-M9 7.2751.00360 LV600 (1PhN/GRD) 115 V/60 Hz, 80W 0,7 A	7.2751.00360 LV600 (1PhN/GRD) 115 V/60 Hz, 80W 0,7 A	7.2751.00360 LV600 (1PhN/GRD) 115 V/60 Hz, 80W 0,7 A	7.2751.00360 LV600 (1PhN/GRD) 115 V/60 Hz, 80W 0,7 A	
line commutation reactor Siemens	-R1 integrated ---	integrated ---	integrated ---	integrated ---	Ersatz für:
ferrit bead Magnetec	-R3.1 -R3.2 7.8538.0 (M112) 2x 7.8538.0 (M112)	7.8538.0 (M112) 2x 7.8538.0 (M112)	7.8538.0 (M112) 2x 7.8538.0 (M112)	7.8538.0 (M112) 2x 7.8538.0 (M112)	
interference suppression filter Siemens	-R11 integrated ---	integrated ---	integrated ---	integrated ---	Ersatz durch:
frequency converter control unit instrument panel Siemens	-T1 7.8833.01150 6SL3210-1PE27-5AL0 7.7830.00710 6SL3244-0BB12-1BAx 7.7830.00100 6SL3255-0AA00-4CA1	7.8833.01150 6SL3210-1PE27-5AL0 7.7830.00710 6SL3244-0BB12-1BAx 7.7830.00100 6SL3255-0AA00-4CA1	7.8833.01160 6SL3210-1PE28-8AL0 7.7830.00710 6SL3244-0BB12-1BAx 7.7830.00100 6SL3255-0AA00-4CA1	7.8833.01160 6SL3210-1PE28-8AL0 7.7830.00710 6SL3244-0BB12-1BAx 7.7830.00100 6SL3255-0AA00-4CA1	
motor cable	-W211 3x 2 AWG / 35 mm² 4 AWG / 25 mm² (GRD) 600 V - 90°C	3x 2 AWG / 35 mm² 4 AWG / 25 mm² (GRD) 600 V - 90°C	3x 1 AWG / 50 mm² 4 AWG / 25 mm² (GRD) 600 V - 90°C	3x 1 AWG / 50 mm² 4 AWG / 25 mm² (GRD) 600 V - 90°C	Ersatz durch:
connection	-W280.1/2 -W281 -W282 2 AWG / 35 mm² 2 AWG / 35 mm² 2 AWG / 35 mm² 600 V - 90°C	2 AWG / 35 mm² 2 AWG / 35 mm² 2 AWG / 35 mm² 600 V - 90°C	2 AWG / 35 mm² 2 AWG / 35 mm² 2 AWG / 35 mm² 600 V - 90°C	2 AWG / 35 mm² 2 AWG / 35 mm² 2 AWG / 35 mm² 600 V - 90°C	
supply terminals U1/V1/W1/GRD Handling Stripped length X connection supply	-X0: 3x 895314.0 3x 895314.00010 4x 895314.00040 Wago 8-1 AWG/10-50 mm² fig. 3, Sht. 12 30 mm fig. 2, Sht. 13	3x 895314.0 3x 895314.00010 4x 895314.00040 Wago 8-1 AWG/10-50 mm² fig. 3, Sht. 12 30 mm fig. 2, Sht. 13	3x 894385.0 3x 894385.00010 4x 894385.00040 Wago 4-4/0 AWG/25-95 mm² fig. 3, Sht. 12 36 mm fig. 2, Sht. 13	3x 894385.0 3x 894385.00010 4x 894385.00040 Wago 25-95 mm² Wago 4-4/0 AWG/25-95 mm² fig. 3, Sht. 12 36 mm fig. 2, Sht. 13	05.02.2018 Datum M.Zeeh Bearbeiter I.M.Zeeh Geprüft Norm Name Datum C-Änderung

model	performance-related components				page 10	11 Bl.
	75 hp EB+ FB (55 kW)	75 hp FB-S (55 kW)	100 hp EB+ FB-C (75 kW)	100 hp FB-S (75 kW)		
machine power supply	460 V ±10 %, 60 Hz	460 V ±10 %, 60 Hz	460 V ±10 %, 60 Hz	460 V ±10 %, 60 Hz	= + UXB.XFC-U3020.04	
overload relay soundproofing casing	-B24 7.8741.00020 3RB3016-1NB0 0,32-1,25 A / S00 setting: 0,57 A Siemens NEC 430.32(C) incremental setting: 0,64 A	7.8741.00020 3RB3016-1NB0 0,32-1,25 A / S00 setting: 0,57 A NEC 430.32(C) incremental setting: 0,64 A	7.8741.00020 3RB3016-1NB0 0,32-1,25 A / S00 setting: 0,57 A NEC 430.32(C) incremental setting: 0,64 A	7.8741.00020 3RB3016-1NB0 0,32-1,25 A / S00 setting: 0,57 A NEC 430.32(C) incremental setting: 0,64 A		
Surge protective device	-F86 Dehn 7.8669.00020 DG MU 3PY 480 3W+ G	7.8669.00020 DG MU 3PY 480 3W+ G	7.8669.00020 DG MU 3PY 480 3W+ G	7.8669.00020 DG MU 3PY 480 3W+ G		
Blower motor	-M1 894717.11000 Siemens 460 V-D/60 Hz 92 A, 3600U	894717.11000 460 V-D/60 Hz 92 A, 3600U	894719.11000 460 V-D/60 Hz 125 A, 3600U	894719.11000 460 V-D/60 Hz 125 A, 3600U		
vent motor soundproofing casing	-M4 895040.00040 Sodeca/ebm HC-31-2T / H-I-E 460 V-Y/60 Hz (3PH/GRD) 210W 0,62 A	895426.0 W4D420 (ebm) 460 V-Y/60 Hz (3PH/GRD) 265W 0,62 A	895040.00040 HC-31-2T / H-I-E 460 V-Y/60 Hz (3PH/GRD) 210W 0,62 A	895426.0 W4D420 (ebm) 460 V-Y/60 Hz (3PH/GRD) 265W 0,62 A		
vent motor control cabinet	-M8/-M9 7.2751.00360 Ruebsamen LV600 (1Ph/N/GRD) 115 V/60 Hz, 80W 0,7 A	7.2751.00360 LV600 (1Ph/N/GRD) 115 V/60 Hz, 80W 0,7 A	7.2751.00360 LV600 (1Ph/N/GRD) 115 V/60 Hz, 80W 0,7 A	7.2751.00360 LV600 (1Ph/N/GRD) 115 V/60 Hz, 80W 0,7 A		
line commutation reactor	-R1 Siemens integrated ---	integrated ---	integrated ---	integrated ---		
ferrit bead	-R3.1 -R3.2 Magnetec 7.8538.00020 (M113) 2x 7.8538.00020 (M113)	7.8538.00020 (M113) 2x 7.8538.00020 (M113)	7.8538.00020 (M113) 1x 7.8538.00020 (M113)	7.8538.00020 (M113) 1x 7.8538.00020 (M113)		
interference suppression filter	-R11 Siemens integrated ---	integrated ---	integrated ---	integrated ---		
frequency converter control unit instrument panel	-T1 7.8833.01170 6SL3210-1PE31-1AL0 7.7830.00710 6SL3244-0BB12-1BAx 7.7830.00100 Siemens 6SL3255-0AA00-4CA1	7.8833.01170 6SL3210-1PE31-1AL0 7.7830.00710 6SL3244-0BB12-1BAx 7.7830.00100 6SL3255-0AA00-4CA1	7.8833.01180 6SL3210-1PE31-5AL0 7.7830.00710 6SL3244-0BB12-1BAx 7.7830.00100 6SL3255-0AA00-4CA1	7.8833.01180 6SL3210-1PE31-5AL0 7.7830.00710 6SL3244-0BB12-1BAx 7.7830.00100 6SL3255-0AA00-4CA1		
motor cable	-W211 3x 2/0 AWG / 70 mm ² 2 AWG / 35 mm ² (GRD) 600 V - 90°C	3x 2/0 AWG / 70 mm ² 2 AWG / 35 mm ² (GRD) 600 V - 90°C	3x 3/0 AWG / 95 mm ² 1 AWG / 50 mm ² (GRD) 600 V - 90°C	3x 3/0 AWG / 95 mm ² 1 AWG / 50 mm ² (GRD) 600 V - 90°C		
connection	-W280.1/2 -W281 -W282 1 AWG / 50 mm ² 1 AWG / 50 mm ² 1 AWG / 50 mm ² 600 V - 90°C	1 AWG / 50 mm ² 1 AWG / 50 mm ² 1 AWG / 50 mm ² 600 V - 90°C	2/0 AWG / 70 mm ² 2/0 AWG / 70 mm ² 2/0 AWG / 70 mm ² 600 V - 90°C	2/0 AWG / 70 mm ² 2/0 AWG / 70 mm ² 2/0 AWG / 70 mm ² 600 V - 90°C		
supply terminals supply	-X0: U1/V1/W1/GRD 3x 894385.0 3x 894385.00010 4x 894385.00040 Wago 4-4/0 AWG/25-95 mm ² fig. 3, Sht. 12 Stripped length X 36 mm connection fig. 2, Sht. 13	3x 894385.0 3x 894385.00010 4x 894385.00040 Wago 4-4/0 AWG/25-95 mm ² fig. 3, Sht. 12 36 mm fig. 2, Sht. 13	3x 894385.0 3x 894385.00010 4x 894385.00040 Wago 4-4/0 AWG/25-95 mm ² fig. 3, Sht. 12 36 mm fig. 2, Sht. 13	3x 894385.0 3x 894385.00010 4x 894385.00040 Wago 4-4/0 AWG/25-95 mm ² fig. 3, Sht. 12 36 mm fig. 2, Sht. 13		

electrical component parts list			
EB+FB			
performance-related components			
KAESER KOMPRESSOREN			
Ursprung:			
Ersatz für:			
Ersatz durch:			
c	Datum	05.02.2018	
b	Bearbeiter	M.Zeeh	
a	Geprüft	IM.Zeeh	
	Norm		
	Name		
	Datum		
	C-Änderung		

model	performance-related components					page 11 11 Bl.
	125 hp FB-C (90 kW)	125 hp FB-S (90 kW)	150 hp FB-C (110 kW)	150 hp FB-S (110 kW)	175 hp FB (132 kW)	
machine power supply	460 V ±10 %, 60 Hz	460 V ±10 %, 60 Hz	460 V ±10 %, 60 Hz	460 V ±10 %, 60 Hz	460 V ±10 %, 60 Hz	= + UXB.XFC-U3020.04
overload relay soundproofing casing Siemens	-B24 7.8741.00020 3RB3016-1NB0 0,32-1,25 A / S00 setting: 0,57 A NEC 430.32(C) incremental setting: 0,64 A	7.8741.00020 3RB3016-1NB0 0,32-1,25 A / S00 setting: 0,57 A NEC 430.32(C) incremental setting: 0,64 A	7.8741.00020 3RB3016-1NB0 0,32-1,25 A / S00 setting: 0,57 A NEC 430.32(C) incremental setting: 0,64 A	7.8741.00020 3RB3016-1NB0 0,32-1,25 A / S00 setting: 0,57 A NEC 430.32(C) incremental setting: 0,64 A	7.8741.00020 3RB3016-1NB0 0,32-1,25 A / S00 setting: 0,57 A NEC 430.32(C) incremental setting: 0,64 A	
Surge protective device Dehn	-F86 7.8669.00020 DG MU 3PY 480 3W+ G	7.8669.00020 DG MU 3PY 480 3W+ G	7.8669.00020 DG MU 3PY 480 3W+ G	7.8669.00020 DG MU 3PY 480 3W+ G	7.8669.00020 DG MU 3PY 480 3W+ G	electrical component parts list FB performance-related components
Blower motor Siemens	-M1 894723.11000 460 V-D/60 Hz 158 A, 1800U	894722.11000 460 V-D/60 Hz 149 A, 3600U	895025.11000 460 V-D/60 Hz 191 A, 1800U	894724.11000 460 V-D/60 Hz 185 A, 3600U	894726.11000 460 V-D/60 Hz 225 A, 1800U	
vent motor soundproofing casing Sodeca/ebm	-M4 895040.00040 HC-31-2T / H-I-E 460 V-Y/60 Hz (3PH/GRD) 210W 0,62 A	895426.0 W4D420 (ebm) 460 V-Y/60 Hz (3PH/GRD) 265W 0,62 A	895040.00040 HC-31-2T / H-I-E 460 V-Y/60 Hz (3PH/GRD) 210W 0,62 A	895426.0 W4D420 (ebm) 460 V-Y/60 Hz (3PH/GRD) 265W 0,62 A	895040.00040 HC-31-2T / H-I-E 460 V-Y/60 Hz (3PH/GRD) 210W 0,62 A	KAESER KOMPRESSOREN Ursprung:
vent motor control cabinet Ruebsamen	-M8/-M9 7.2751.00360 LV600 (1Ph/N/GRD) 115 V/60 Hz, 80W 0,7 A	7.2751.00360 LV600 (1Ph/N/GRD) 115 V/60 Hz, 80W 0,7 A	7.2751.00360 LV600 (1Ph/N/GRD) 115 V/60 Hz, 80W 0,7 A	7.2751.00360 LV600 (1Ph/N/GRD) 115 V/60 Hz, 80W 0,7 A	7.2751.00360 LV600 (1Ph/N/GRD) 115 V/60 Hz, 80W 0,7 A	
line commutation reactor Siemens	-R1 integrated ---	integrated ---	integrated ---	integrated ---	integrated ---	Ersatz für:
ferrit bead Magnetec	-R3.1 -R3.2 7.8538.00020 (M113) 1x 7.8538.00020 (M113)	7.8538.00020 (M113) 1x 7.8538.00020 (M113)	7.8538.00020 (M113) 1x 7.8538.00020 (M113)	7.8538.00020 (M113) 1x 7.8538.00020 (M113)	7.8538.00020 (M113) 1x 7.8538.00020 (M113)	
interference suppression filter Siemens	-R11 integrated ---	integrated ---	integrated ---	integrated ---	integrated ---	Ersatz durch:
frequency converter control unit instrument panel Siemens	-T1 7.8833.01190 6SL3210-1PE31-8AL0 7.7830.00710 6SL3244-0BB12-1BAx 7.7830.00100 6SL3255-0AA00-4CA1	7.8833.01190 6SL3210-1PE31-8AL0 7.7830.00710 6SL3244-0BB12-1BAx 7.7830.00100 6SL3255-0AA00-4CA1	7.8833.01200 6SL3210-1PE32-1AL0 7.7830.00710 6SL3244-0BB12-1BAx 7.7830.00100 6SL3255-0AA00-4CA1	7.8833.01200 6SL3210-1PE32-1AL0 7.7830.00710 6SL3244-0BB12-1BAx 7.7830.00100 6SL3255-0AA00-4CA1	7.8833.01210 6SL3210-1PE32-5AL0 7.7830.00710 6SL3244-0BB12-1BAx 7.7830.00100 6SL3255-0AA00-4CA1	
motor cable	-W211 3x 4/0 AWG / 120 mm ² 2/0 AWG / 70 mm ² (GRD) 600 V - 90°C	3x 4/0 AWG / 120 mm ² 2/0 AWG / 70 mm ² (GRD) 600 V - 90°C	3x 4/0 AWG / 120 mm ² 2/0 AWG / 70 mm ² (GRD) 600 V - 90°C	3x 4/0 AWG / 120 mm ² 2/0 AWG / 70 mm ² (GRD) 600 V - 90°C	3x 4/0 AWG / 120 mm ² 2/0 AWG / 70 mm ² (GRD) 600 V - 90°C	Datum 05.02.2018
connection	-W280.1/2 -W281 -W282 3/0 AWG / 95 mm ² 3/0 AWG / 95 mm ² 3/0 AWG / 95 mm ² 600 V - 90°C	3/0 AWG / 95 mm ² 3/0 AWG / 95 mm ² 3/0 AWG / 95 mm ² 600 V - 90°C	4/0 AWG / 120 mm ² 4/0 AWG / 120 mm ² 4/0 AWG / 120 mm ² 600 V - 90°C	4/0 AWG / 120 mm ² 4/0 AWG / 120 mm ² 4/0 AWG / 120 mm ² 600 V - 90°C	2x 2/0 AWG / 70 mm ² 4/0 AWG / 120 mm ² 4/0 AWG / 120 mm ² 600 V - 90°C	
supply terminals Handling Stripped length X	-X0: U1/N1/W1 6x 894385.0 3x 894385.00030 3x 894385.00040 Wago 4-4/0AWG / 25-95mm ² fig. 3, Sht. 13 36 mm	6x 894385.0 3x 894385.00030 3x 894385.00040 Wago 4-4/0AWG / 25-95mm ² fig. 3, Sht. 13 36 mm	6x 895545.0 3x 895545.00030 3x 895545.00040 Wago (50-185mm ²) 1 AWG - 350 MCM fig. 3, Sht. 13 45 mm	6x 895545.0 3x 895545.00030 3x 895545.00040 Wago (50-185mm ²) 1 AWG - 350 MCM fig. 3, Sht. 13 45 mm	6x 895545.0 3x 895545.00030 3x 895545.00040 Wago (50-185mm ²) 1 AWG - 350 MCM fig. 3, Sht. 13 45 mm	Geprüft M.Zeeh
PE-rail Torque Stripped length X	-X0:PE 832489.00010 15Nm 25 mm+ Conductor crimp pins	832489.00010 15Nm 25 mm+ Conductor crimp pins	832489.00010 15Nm 25 mm+ Conductor crimp pins	832489.00010 15Nm 25 mm+ Conductor crimp pins	832489.00010 15Nm 25 mm+ Conductor crimp pins	Norm
supply	-connection fig. 3, Sht. 15	fig. 3, Sht. 15	fig. 3, Sht. 15	fig. 3, Sht. 15	fig. 3, Sht. 15	Name
						Datum
						C-Änderung

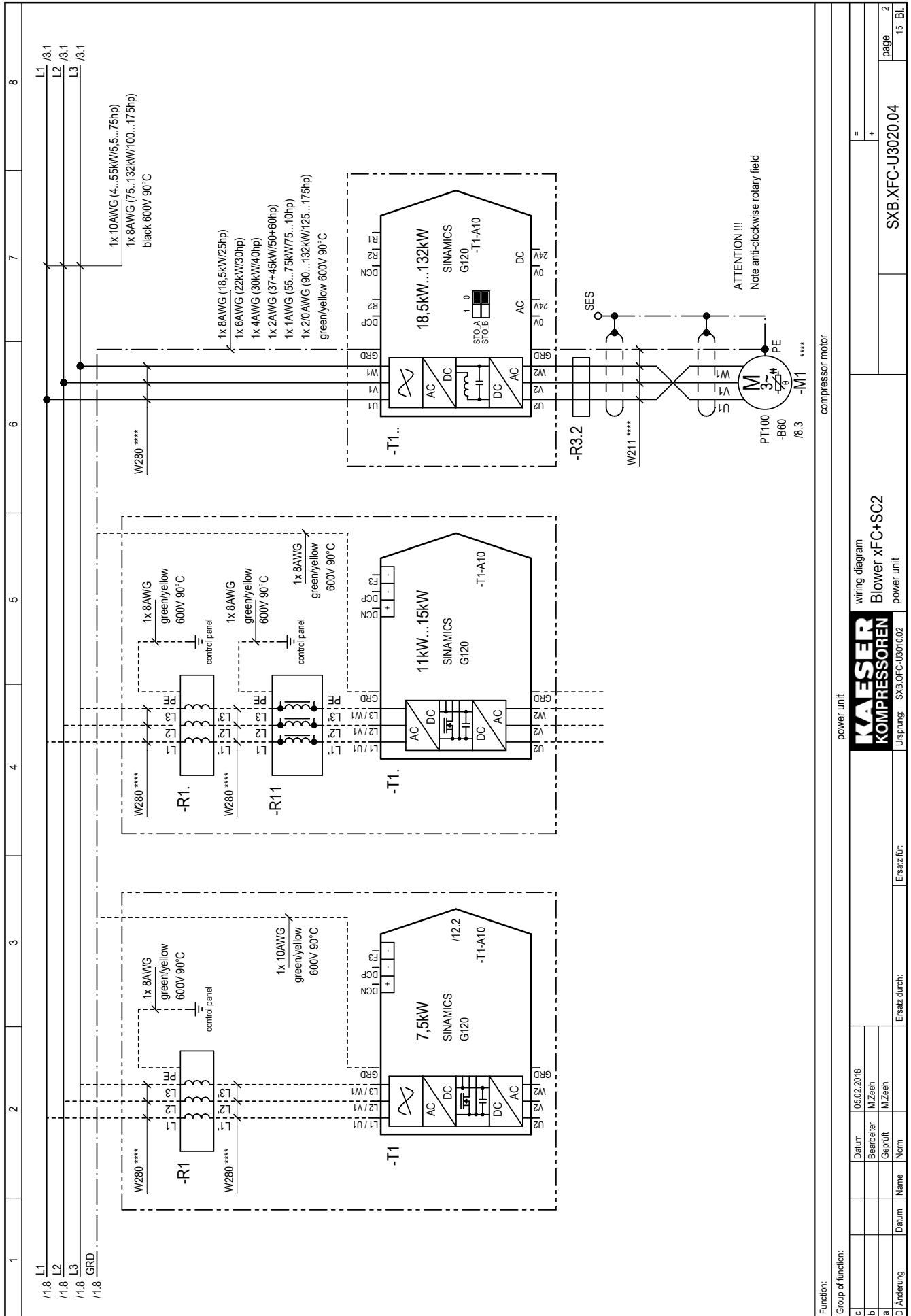

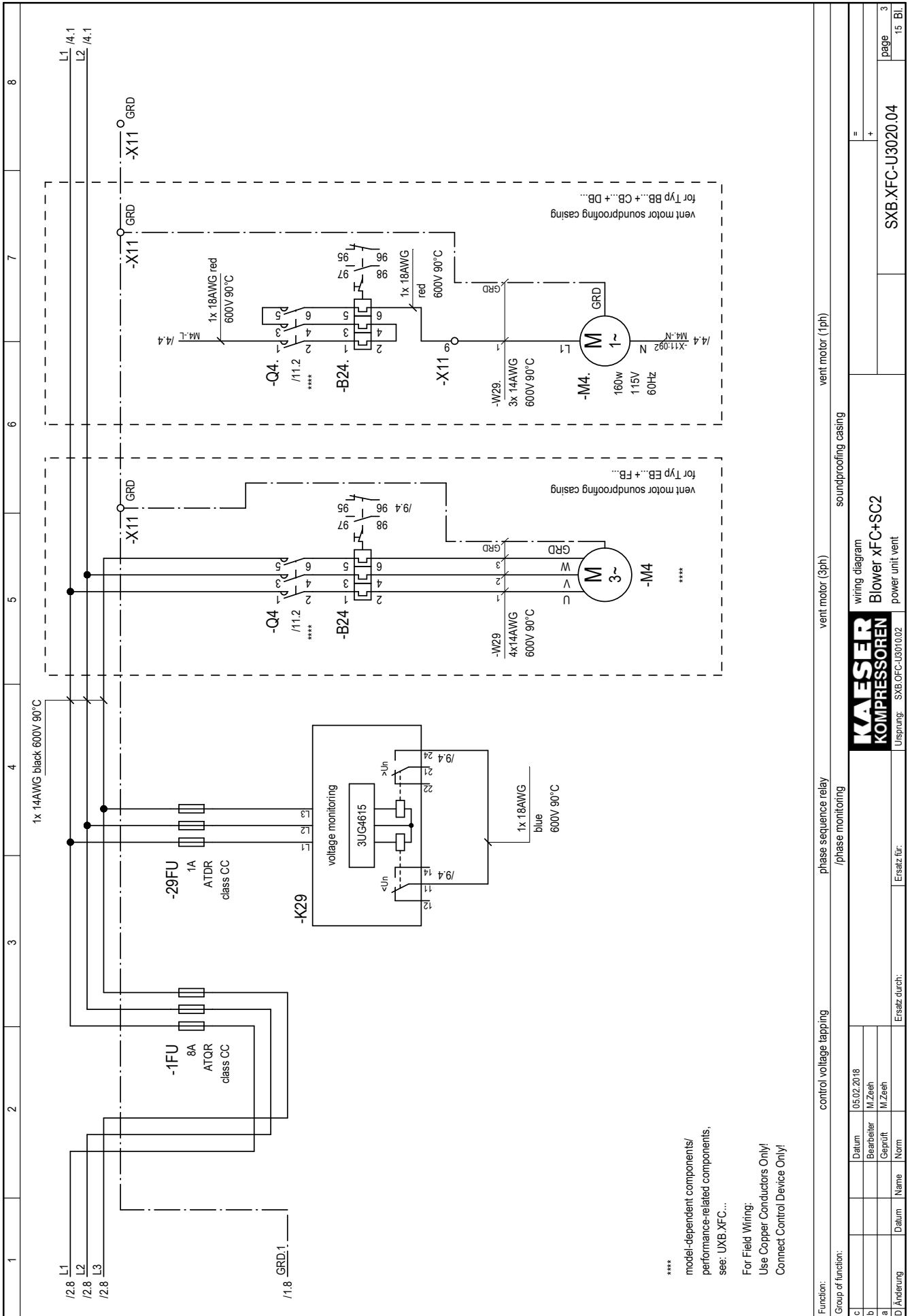

Function:		control voltage tapping	phase sequence relay /phase monitoring	soundproofing casing	vent motor (3ph)	vent motor (1ph)
Group of function:						
c	Datum	05.02.2018				
b	Bearbeiter	M.Zeeh				
a	Geprüft	M.Zeeh				
D	Änderung	Datum	Name	Norm	Ersatz durch:	Ersatz für:
				wiring diagram		
				Blower xFC+SC2		
				power unit vent		
				SXB.DFC-LB3010.02		
				Ursprung:		
				SXB.XFC-U3020.04		
				page		3
				15 Bl.		

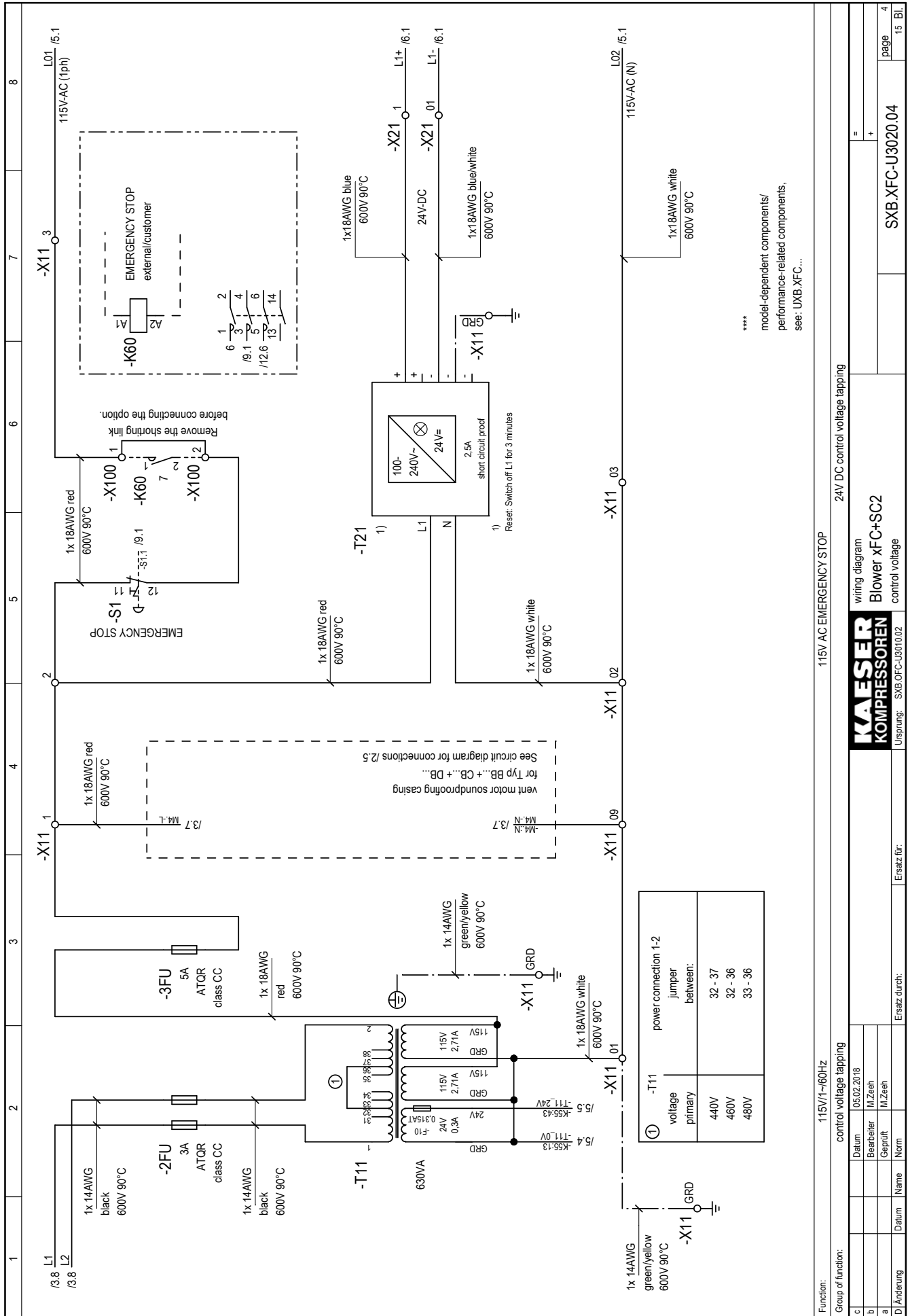

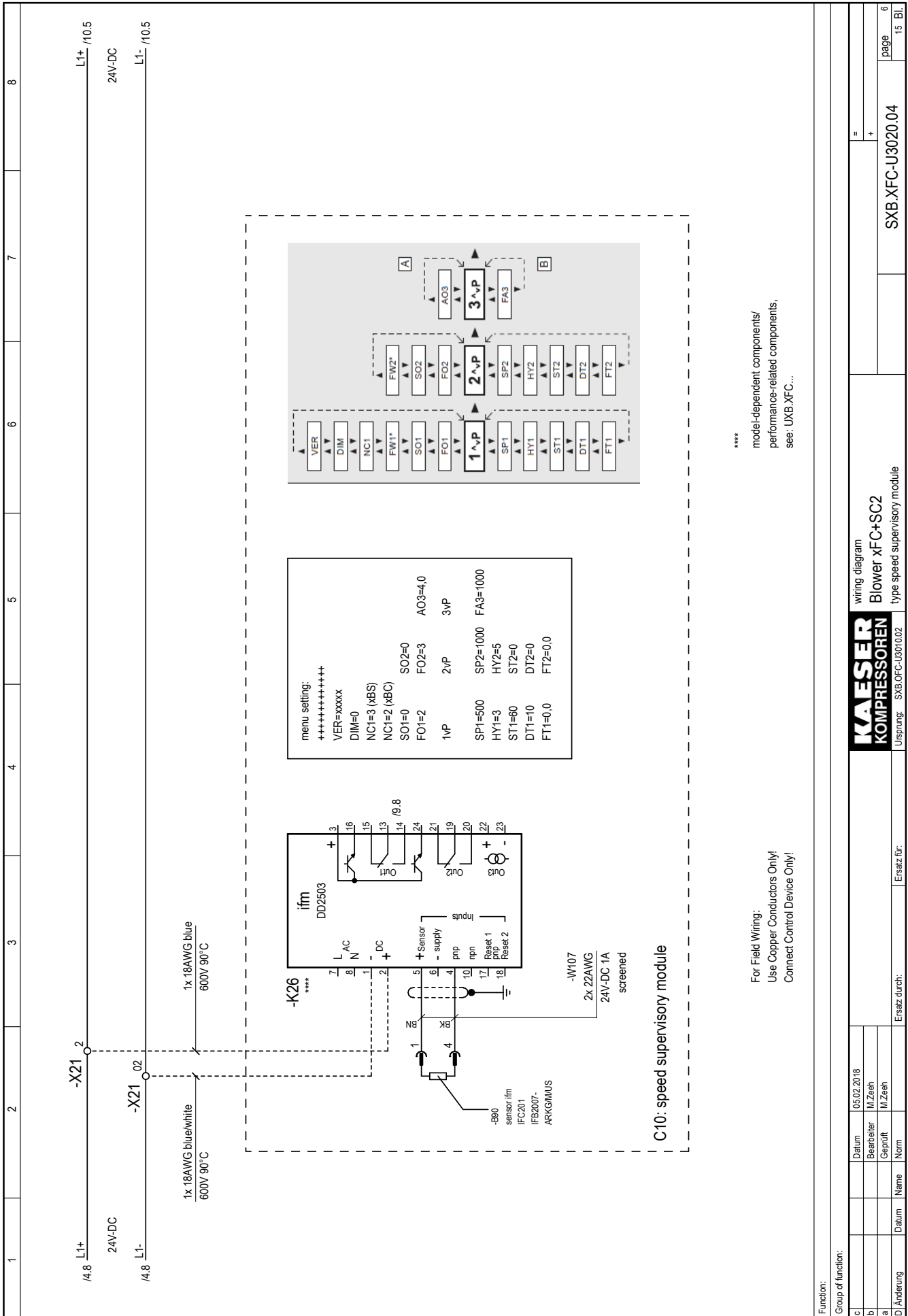

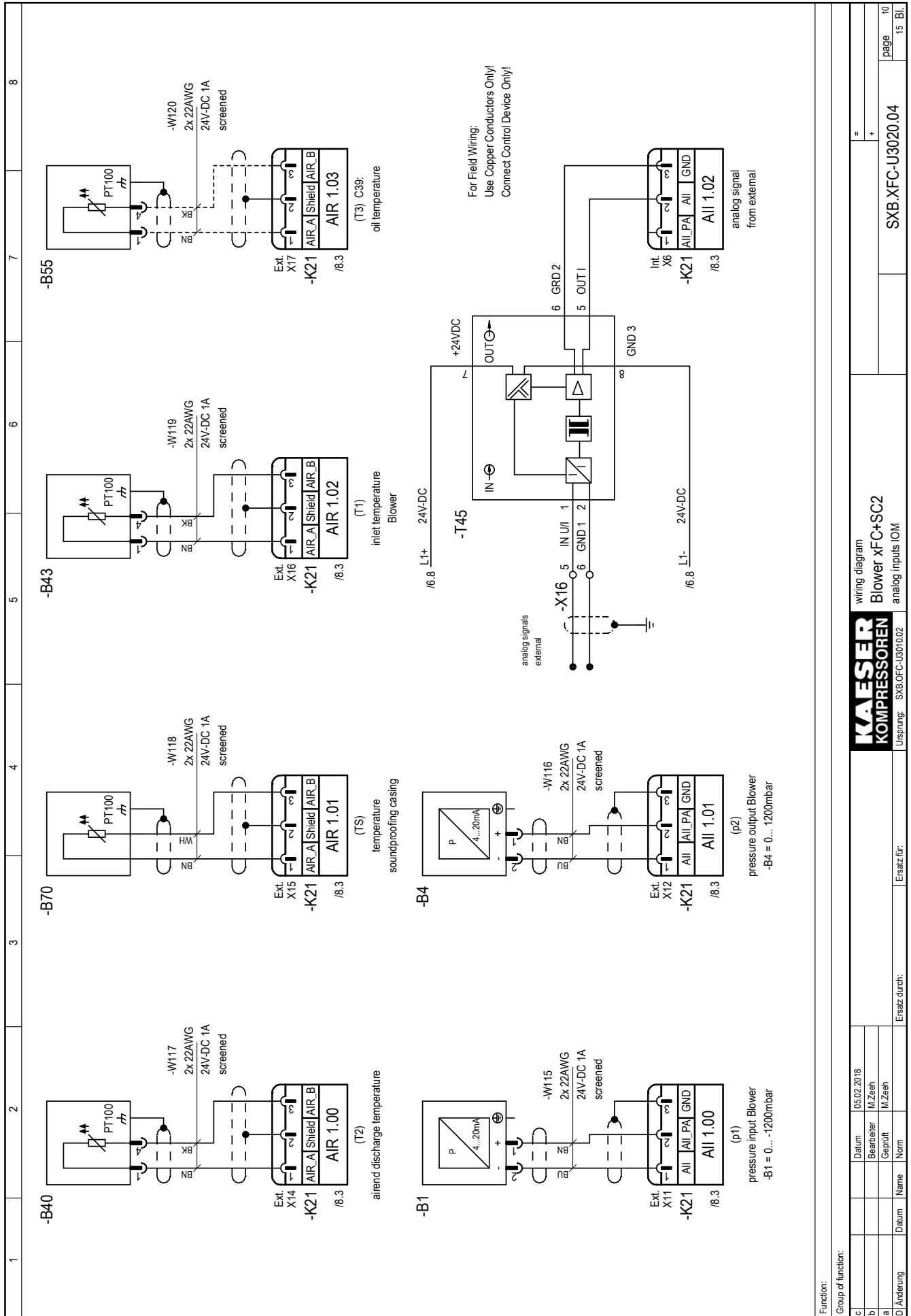

Function:		wiring diagram	
Group of function:		Blower xFC+SC2	
c	Datum	05.02.2018	=
b	Bearbeiter	M.Zeeh	+
a	Geprüft	M.Zeeh	
D/Änderung	Datum	Name	Norm
Ersatz durch:		Ersatz durch:	
URSPRUNG: SXB.DFC-LB3010.02		SXB.XFC-U3020.04	
		page 10	
		15 Bl.	

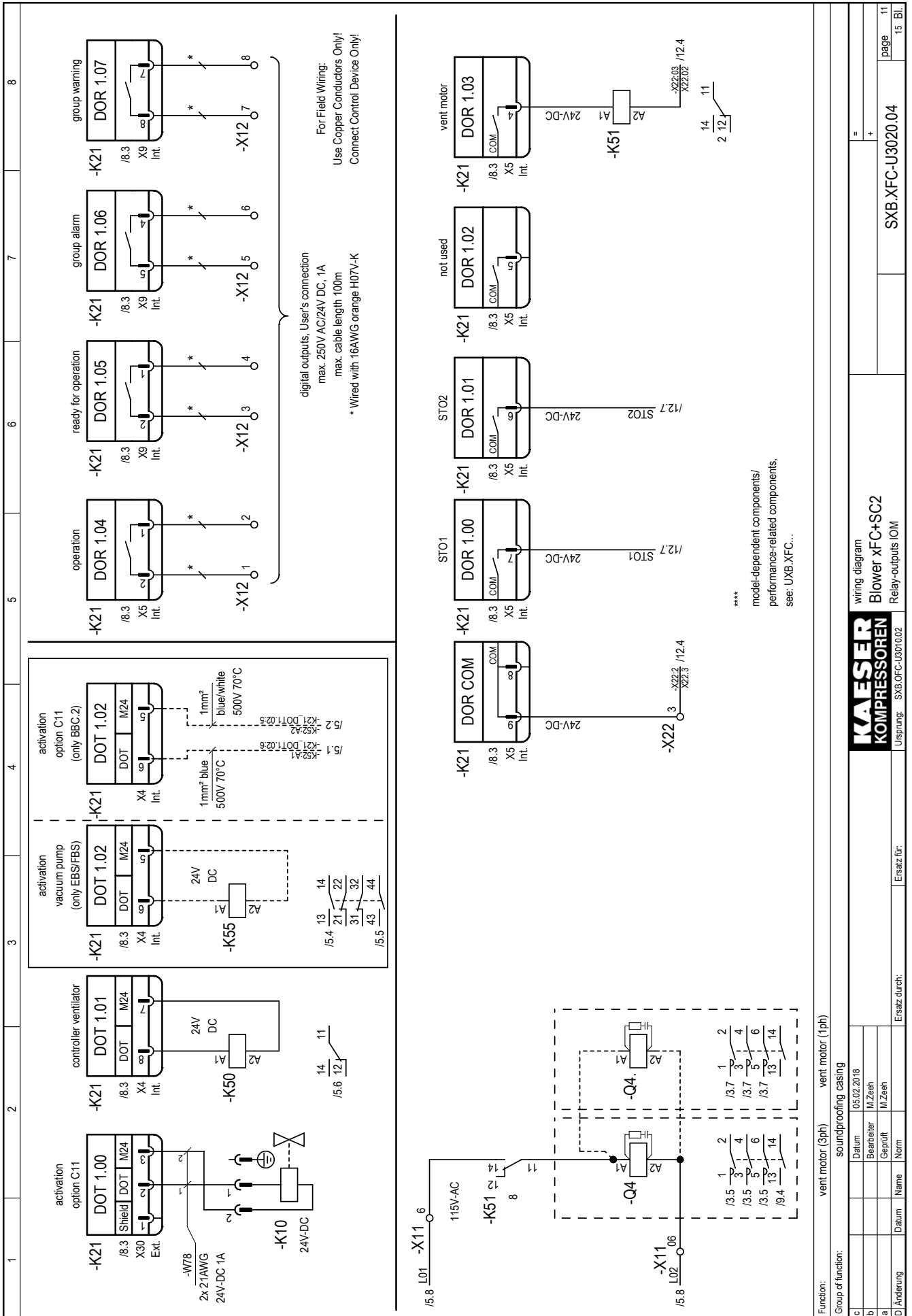

1 2 3 4 5 6 7 8

fig.: 1 Handling control line terminal

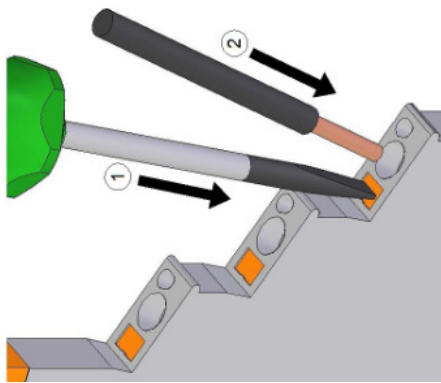

fig.: 2 Handling supply terminals

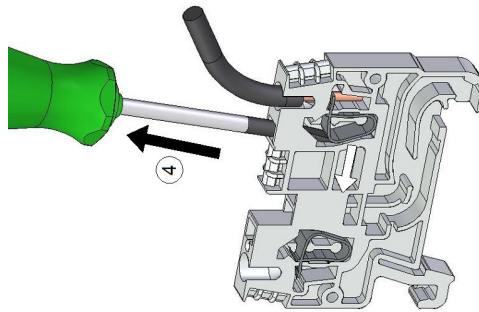
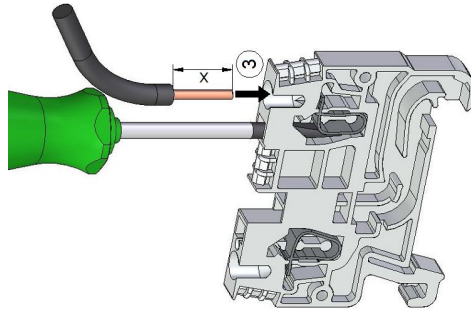
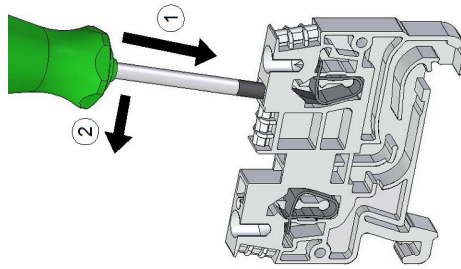
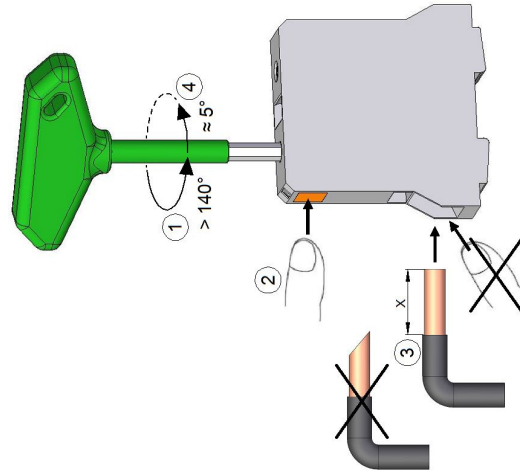

fig.: 3 Handling supply terminals



Function:

Group of function:

c	Datum	05.02.2018
b	Bearbeiter	M.Zeesh
a	Geprüft	M.Zeesh
d	Änderung	Datum Name Norm

Ersatz durch:

Ersatz für:

KAESER
KOMPRESSOREN
Ursprung: SXB.DFC-LB3010.02

wiring diagram
Blower xFC+SC2
Handling terminals

SXB.XFC-U3020.04

page 13
15 Bl.

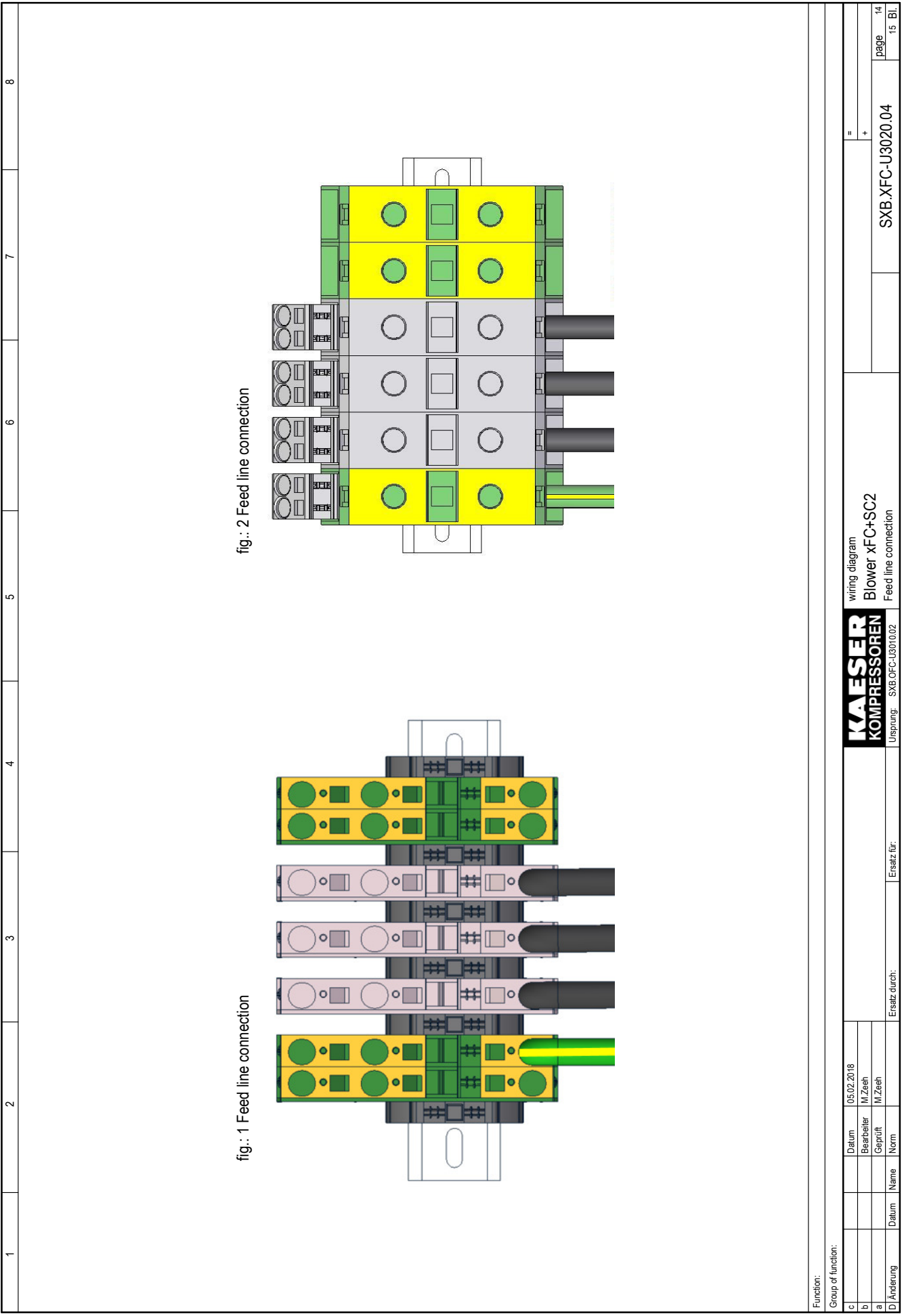

Function:		wiring diagram		=	
Group of function:		Blower xFC+SC2		+	
c	Datum	05.02.2018			
b	Bearbeiter	M.Zeesh			
a	Geprüft	M.Zeesh			
D	Änderung	Datum	Name	Ersatz durch:	Ersatz für:
			SX.B.XFC-U3020.04		
			page 14		
			15 Bl.		

1 2 3 4 5 6 7 8

fig.: 3 Feed line connection

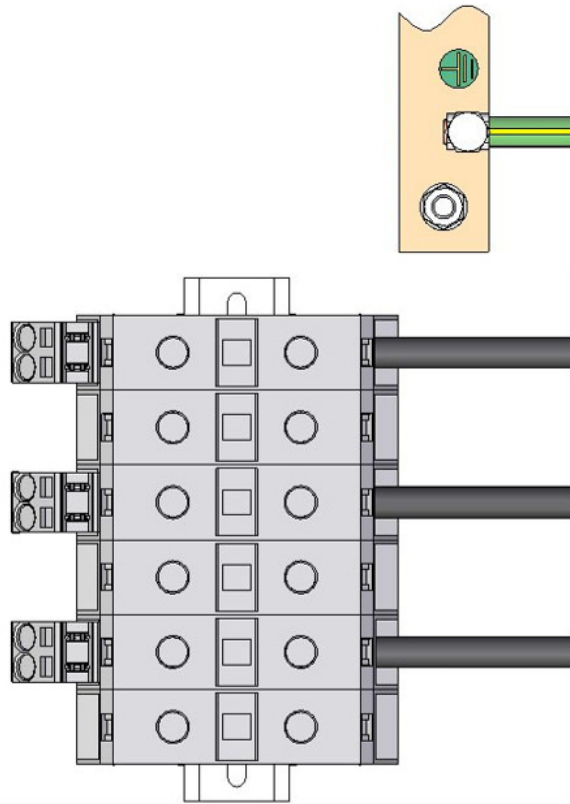

Function:			
Group of function:			
c	Datum	05.02.2018	=
b	Bearbeiter	M.Zeesh	+
a	Geprüft	M.Zeesh	
D	Änderung	Datum	Name
Ersatz durch:		Ersatz für:	
		SXB.DFC-L83010.02	
		wiring diagram	
		Blower xFC+SC2	
		Feed line connection	
		SXB.XFC-U3020.04	
		page	15
		15 Bl.	

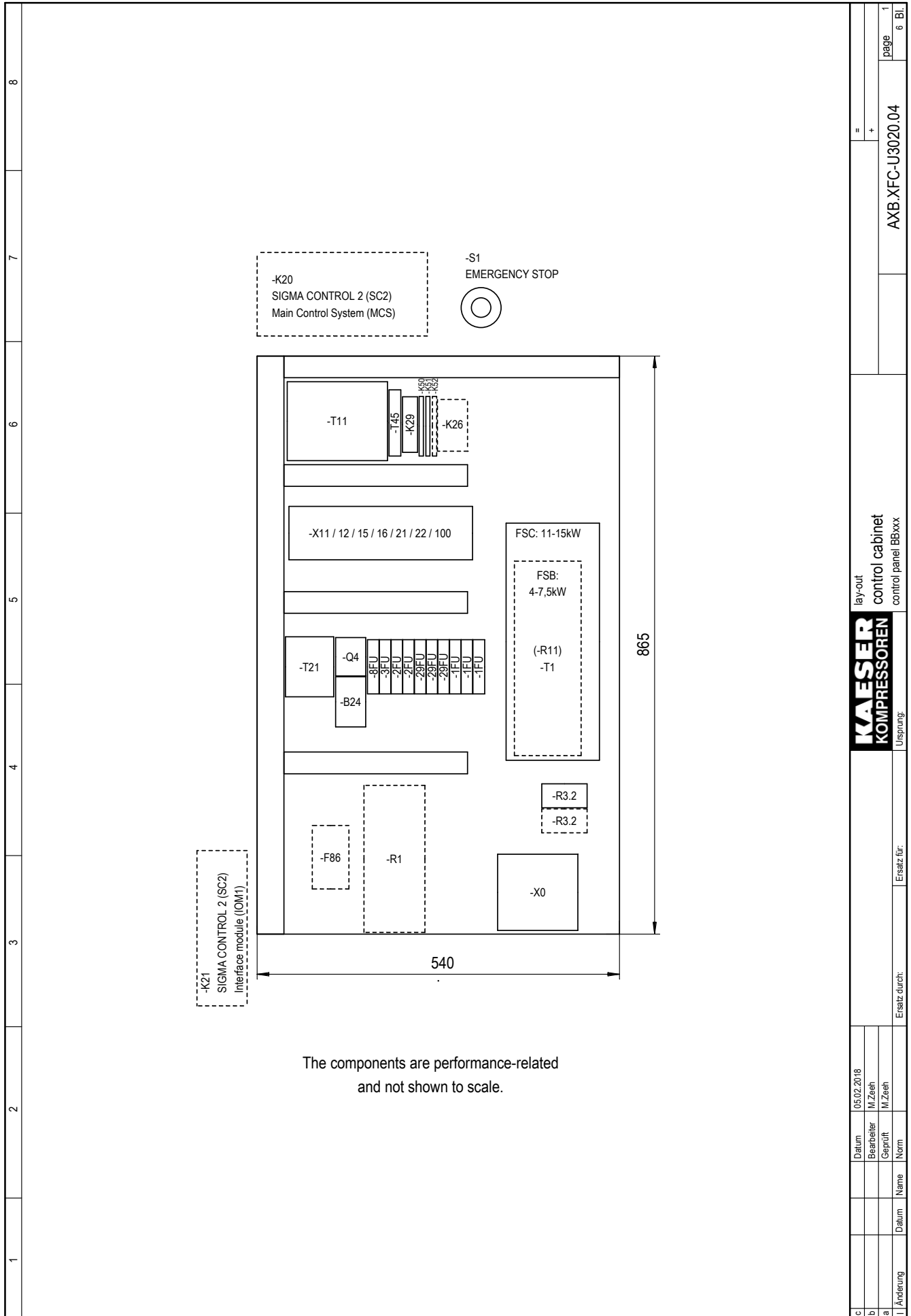

=		+		AXB.XFC-U3020.04		page 1	6 Bl.
lay-out control cabinet control panel BBxxx				KAESER KOMPRESSOREN			
KOMPRESSOREN				Ursprung:			
Datum		05.02.2018		Ersatz durch:			
Bearbeiter		M.Zeeh		Ersatz durch:			
Geprüft		M.Zeeh		Ersatz durch:			
Norm				Ersatz durch:			
Name				Ersatz durch:			
Datum				Ersatz durch:			
Änderung				Ersatz durch:			

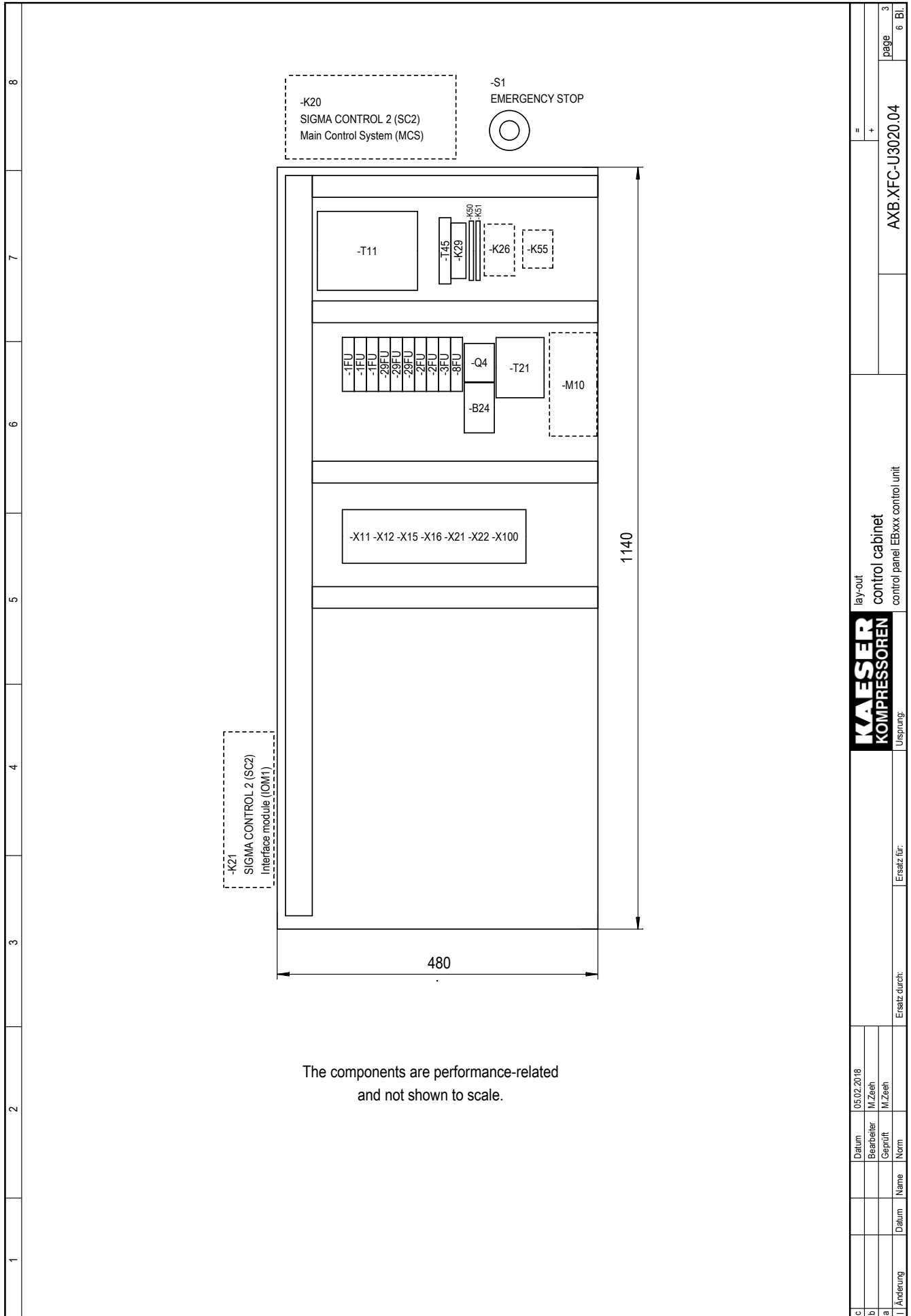

=		+		AXB.XFC-U3020.04		page 3	6 Bl.
lay-out control cabinet				control panel EBxxx control unit			
KAESER KOMPRESSOREN				Ursprung:			
Datum		05.02.2018		Ersatz durch:			
Bearbeiter		M.Zeeh		Ersatz durch:			
Geprüft		M.Zeeh		Ersatz durch:			
Norm				Ersatz durch:			
Datum				Ersatz durch:			
Name				Ersatz durch:			
Änderung				Ersatz durch:			

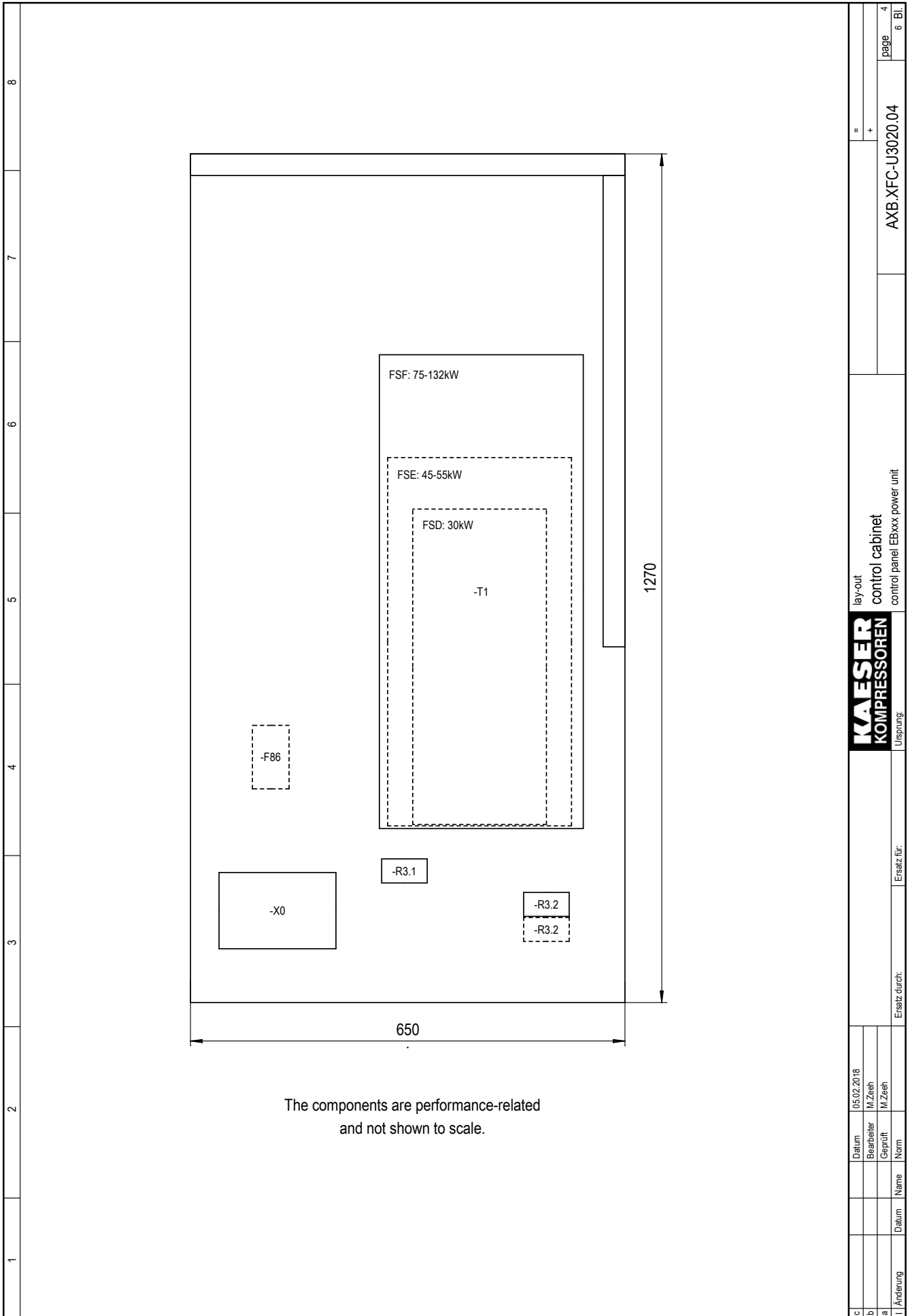

The components are performance-related and not shown to scale.

=		+		AXB.XFC-U3020.04		page 4	
						6 Bl.	
lay-out control cabinet				control panel EBxxx power unit			
KAESER KOMPRESSOREN				Ursprung:			
Datum		05.02.2018		Ersatz durch:			
Bearbeiter		M.Zeeh		Ersatz für:			
Geprüft		M.Zeeh		Ersatz durch:			
Name				Ersatz durch:			
Datum				Ersatz durch:			
I Änderung				Ersatz durch:			

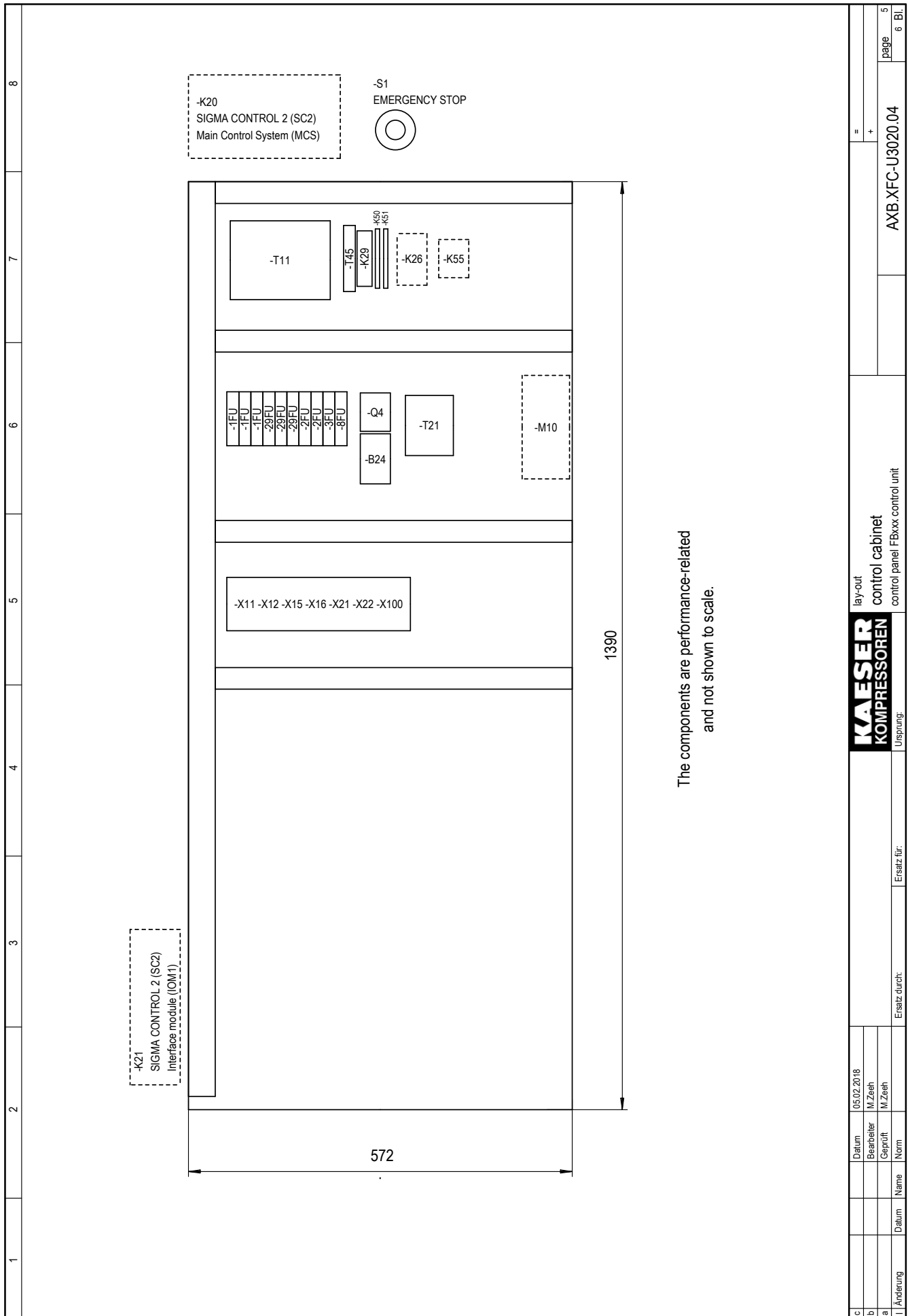

The components are performance-related and not shown to scale.

c		Datum	05.02.2018	lay-out		control cabinet		=		page	5
b		Bearbeiter	M.Zeeh	control panel FBxxx control unit		AXB.XFC-U3020.04		+		page	6 Bl.
a		Geprüft	M.Zeeh	KOMPRESSOREN		KOMPRESSOREN		Ursprung:			
I		Änderung	Datum	Name	Ersatz durch:						

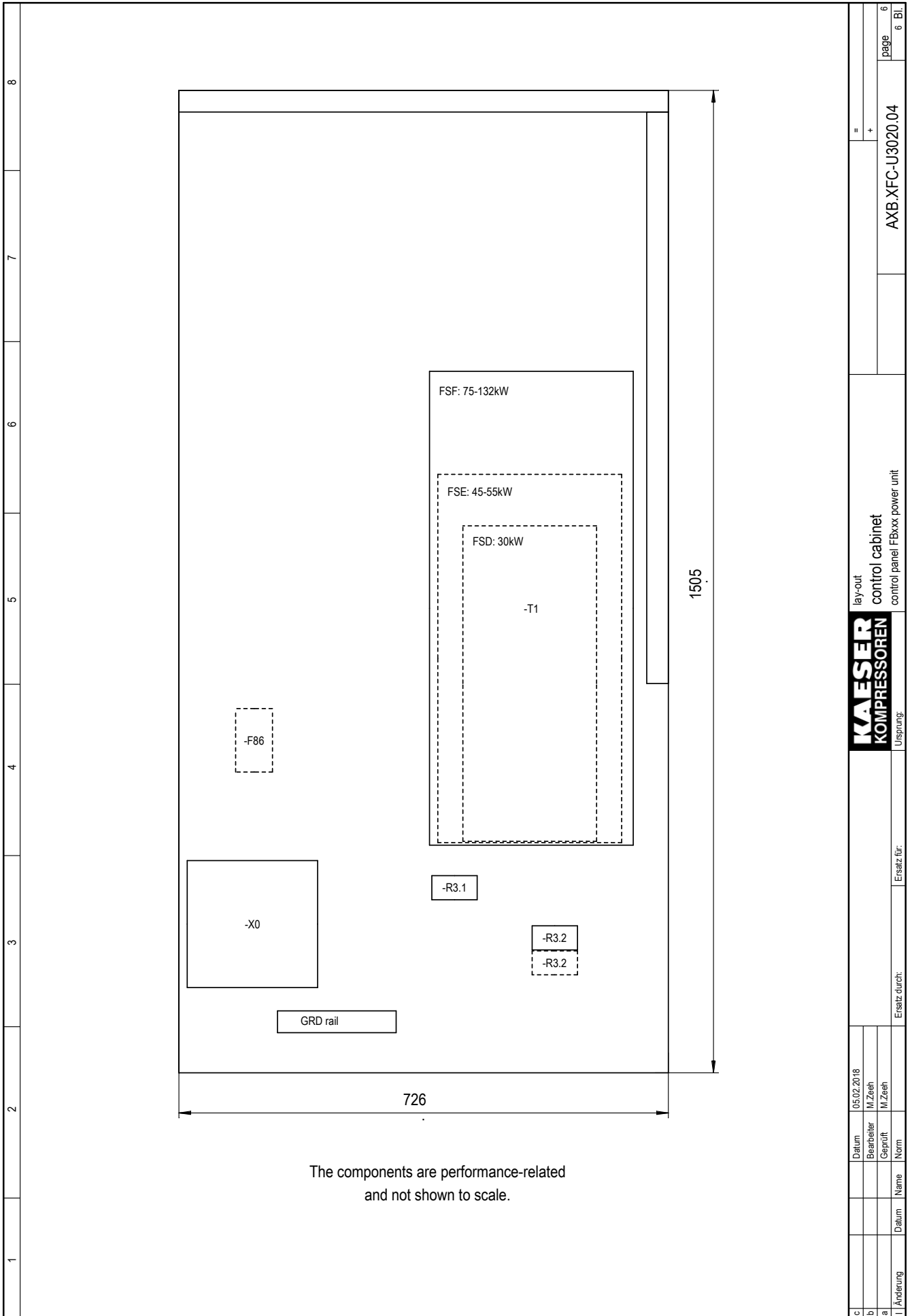

lay-out		control cabinet		control panel FBxxx power unit		AXB.XFC-U3020.04		page 6	
=		+						6 Bl.	
Kaeser logo		Kaeser logo		Kaeser logo		Kaeser logo		Kaeser logo	
Datum		05.02.2018		Ersatz durch:		Ersatz für:		Ersatz durch:	
Bearbeiter		M.Zeeh		Ersatz durch:		Ersatz für:		Ersatz durch:	
Geprüft		M.Zeeh		Ersatz durch:		Ersatz für:		Ersatz durch:	
Norm				Ersatz durch:		Ersatz für:		Ersatz durch:	
Name				Ersatz durch:		Ersatz für:		Ersatz durch:	
Datum				Ersatz durch:		Ersatz für:		Ersatz durch:	
I Änderung				Ersatz durch:		Ersatz für:		Ersatz durch:	

13.5 Project planning data